

General Description

The AOZ1019 evaluation board is a fully assembled and tested circuit board built with the AOZ1019 buck regulator IC. It outputs a preset or adjustable voltage and up to 2A of continuous current. The evaluation board requires an input voltage from 4.5V to 16V. The output voltage is preset and can be adjusted from 0.8V to $V_{IN}-0.4V$

The AOZ1019-EVA circuit features include; current limit, short circuit protection, input under voltage lock out, internal soft start and thermal shut down. It operates at a fixed 500kHz switching frequency. The current mode control and integrated internal MOSFET minimize component count, board area and total cost.

The AOZ1019 comes in an SO-8 package and is rated over a $-40^{\circ}C$ to $+85^{\circ}C$ ambient temperature range.

Features

- 4.5V to 16V operating input voltage range
- Output voltage was preset to 3.3V, adjustable down to 0.8V
- 2A continuous output current
- Fixed 500kHz PWM operation
- Internal soft start
- Cycle-by-cycle current limit
- Short-circuit protection
- Thermal shutdown

Applications

- Point of load DC/DC conversion
- PCIe graphics cards
- Set top boxes
- DVD drives and HDD
- LCD panels
- Cable modems
- Telecom/networking/datacom equipment

Evaluation Board Schematic

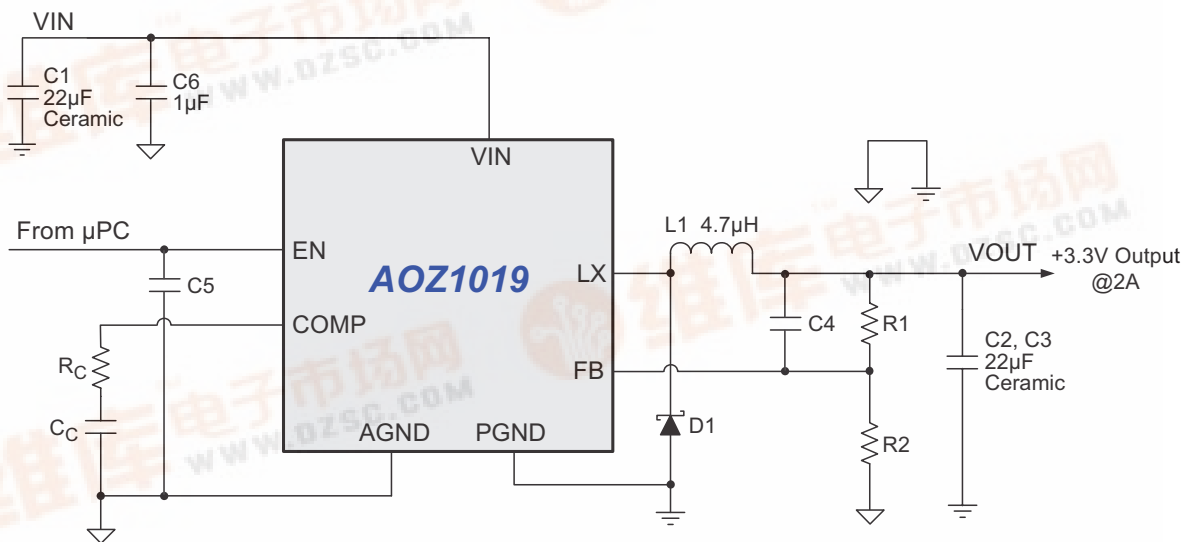

Figure 1.

Component List

Ref Designation	Value	Description	Manufacturer Part Number	Manufacturer
C1	22μF	Ceramic Cap, 22μF, 25V, 1210, X5R	GRM32ER61E226KE15L	Murata
C2	22μF	Ceramic Cap, 22μF, 25V, 1210, X5R	GRM32ER61E226KE15L	
C3	22μF	Ceramic Cap, 22μF, 25V, 1210, X5R	GRM32ER61E226KE15L	
C4	NU			
C5	1000pF	Ceramic Cap, 1000pF, 50V, 0603, X7R	GRM188R71E102K	
C6	1μF	Ceramic Cap, 1μF, 25V, 0603, X5R	GRM188R61E105KA12D	
C _C	1000pF	Ceramic Cap, 1000pF, 50V, 0603, X7R	GRM188R71E102K	
R1 ⁽¹⁾	31.6kΩ	Thick Film Res, 1%, 31.6k, 0603	CRCW060331K6FKTAP	DALE
R2	20kΩ	Thick Film Res, 1%, 20k, 0603	CRCW060321K0FKTAP	
R _C	20kΩ	Thick Film Res, 1%, 20k, 0603	CRCW060321K0FKTAP	
L1	4.7μH	Inductor, 4.7μH, 2.9A	LQH55DN3R3M03	Murata
D1		Schottky Barrier Diode, 2A, 30V, SMA	B230A-FDICT-ND	DIODES
U1	AOZ1019AI	Buck Regulator IC, 2A, 16V	AOZ1019AI	AOS

Note:

1. Output voltage is set by R1; $R1 = \frac{8 + (10 \times V_O)}{0.8k\Omega}$. Table 1 shows that the value of R1 with typical output voltages.

Table 1.

V _O (V)	R1 (kΩ)
1.2	4.99
1.8	12.7
2.5	21.5
3.3	31.6
5.0	52.3

PCB Layout

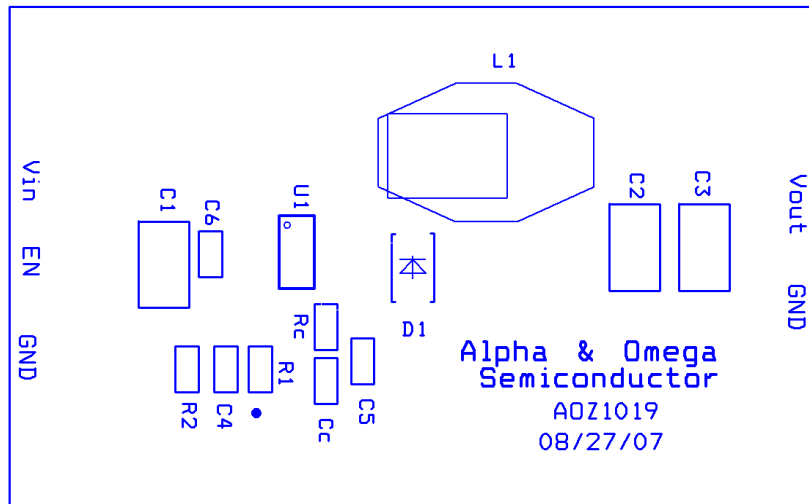

Figure 1. Top Silk Screen

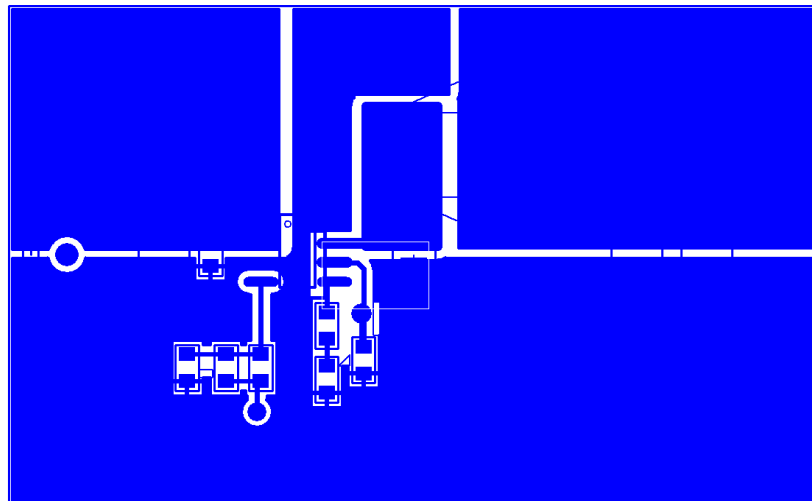

Figure 2. Top Layer

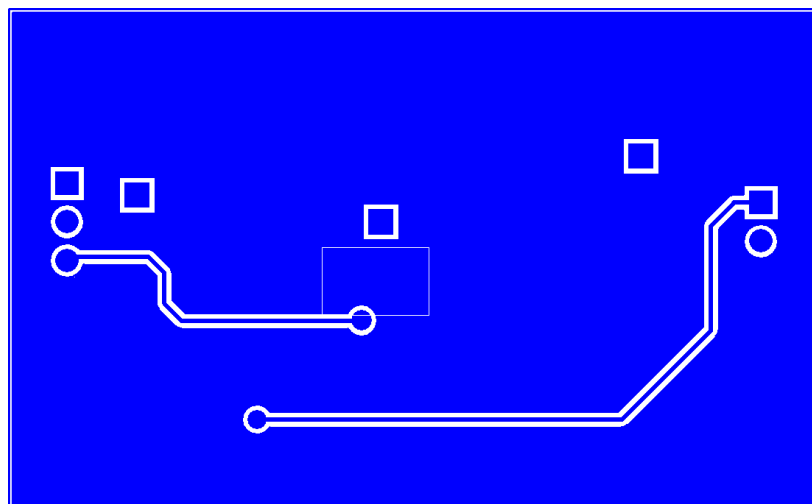

Figure 3. Bottom Layer

Quick Start Guide

1. Connect the terminals of load to +V_{OUT} pins and GND pins. Set load current to between 0A and 2A.
2. Connect the DC power supply to +V_{IN} pin and GND pins. Set DC power supply voltage to between 4.5V and 16V.
3. Connect EN pin to +V_{IN} or any voltage source which is higher than 2V and less than 16V.
4. Turn on DC power supply and evaluation circuit will start.
5. Measure input voltage at the +V_{IN} pin and GND pins to eliminate the effect of voltage drop on wire between DC power supply and evaluation board.
6. Measure output voltage at the +V_{OUT} pin and GND pins to eliminate the effect of voltage drop on wire between load and evaluation board.
7. Use an oscilloscope to monitor input ripple voltage right across input capacitor C1.
8. Use an oscilloscope to monitor output ripple voltage right across output capacitor C2.

This datasheet contains preliminary data; supplementary data may be published at a later date. Alpha & Omega Semiconductor reserves the right to make changes at any time without notice.

LIFE SUPPORT POLICY

ALPHA & OMEGA SEMICONDUCTOR PRODUCTS ARE NOT AUTHORIZED FOR USE AS CRITICAL COMPONENTS IN LIFE SUPPORT DEVICES OR SYSTEMS.

As used herein:

1. Life support devices or systems are devices or systems which, (a) are intended for surgical implant into the body or (b) support or sustain life, and (c) whose failure to perform when properly used in accordance with instructions for use provided in the labeling, can be reasonably expected to result in a significant injury of the user.

2. A critical component in any component of a life support, device, or system whose failure to perform can be reasonably expected to cause the failure of the life support device or system, or to affect its safety or effectiveness.