



VOLTAGE DETECTOR

AZ70XX

General Description

The AZ70XX series ICs are under voltage detectors with a built in voltage threshold and low power consumption. The AZ70XX are specifically designed to accurately monitor power supplies.

The AZ70XX use a precision on-chip voltage reference and a comparator to measure the input operating voltage. These ICs can accurately reset the system after detecting voltage at the time of switching power on and instantaneous power off in various CPU systems and other logic systems. The detect voltage thresholds are 2.3V/2.5V/2.7V/2.9V/3.1V/3.3V/4.2V/4.5V for AZ7023/25/27/29/31/33/42/45 respectively. Built in hysteresis helps to prevent erratic operation in the presence of noise.

The AZ70XX series are available in 2 standard packages: TO-92 and SOT-89-3.

Features

- Low Current Consumption:
I_{CCL}=300μA Typical
I_{CCH}=30μA Typical
- Low Minimum Operating Voltage for Output Resetting: 0.8V Typical
- Built in Hysteresis Voltage: 50mV Typical
- Open Collector Output
- Extended Temperature Range: -40 to 85°C

Applications

- Low Battery Voltage Detector
- Power Fail Indicator
- Processor Reset Generator
- Battery Backup Control
- Home Electric Appliances



Figure 1. Package Types of AZ70XX





VOLTAGE DETECTOR

AZ70XX

Pin Configuration

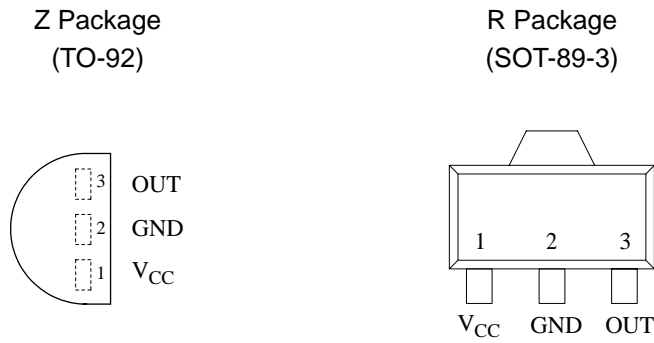

Figure 2. Pin Configuration of AZ70XX (Top View)

Functional Block Diagram

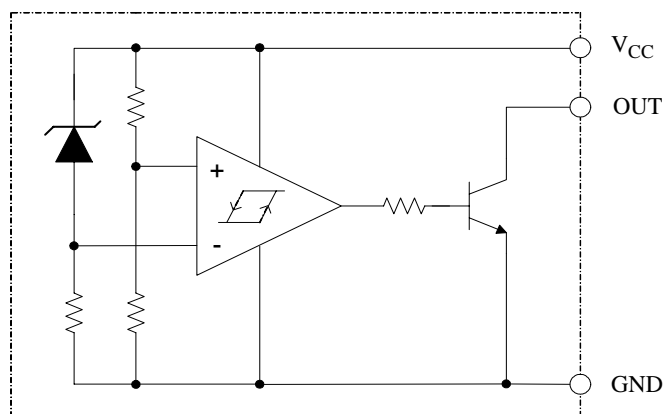
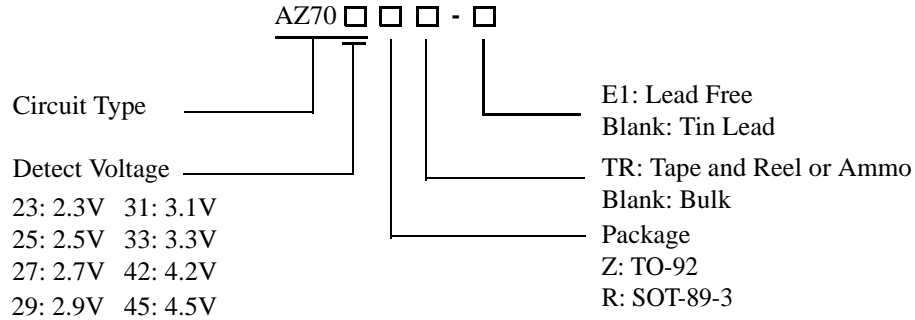

Figure 3. Functional Block Diagram of AZ70XX



VOLTAGE DETECTOR **AZ70XX**

Ordering Information



Package	Temperature Range	Detector Voltage	Part Number		Marking ID		Packing Type
			Tin Lead	Lead Free	Tin Lead	Lead Free	
TO-92	-40 to 85°C	2.3V	AZ7023Z	AZ7023Z-E1	AZ7023Z	AZ7023Z-E1	Bulk
			AZ7023ZTR	AZ7023ZTR-E1	AZ7023Z	AZ7023Z-E1	Ammo
		2.5V	AZ7025Z	AZ7025Z-E1	AZ7025Z	AZ7025Z-E1	Bulk
			AZ7025ZTR	AZ7025ZTR-E1	AZ7025Z	AZ7025Z-E1	Ammo
		2.7V	AZ7027Z	AZ7027Z-E1	AZ7027Z	AZ7027Z-E1	Bulk
			AZ7027ZTR	AZ7027ZTR-E1	AZ7027Z	AZ7027Z-E1	Ammo
		2.9V	AZ7029Z	AZ7029Z-E1	AZ7029Z	AZ7029Z-E1	Bulk
			AZ7029ZTR	AZ7029ZTR-E1	AZ7029Z	AZ7029Z-E1	Ammo
		3.1V	AZ7031Z	AZ7031Z-E1	AZ7031Z	AZ7031Z-E1	Bulk
			AZ7031ZTR	AZ7031ZTR-E1	AZ7031Z	AZ7031Z-E1	Ammo
		3.3V	AZ7033Z	AZ7033Z-E1	AZ7033Z	AZ7033Z-E1	Bulk
			AZ7033ZTR	AZ7033ZTR-E1	AZ7033Z	AZ7033Z-E1	Ammo
		4.2V	AZ7042Z	AZ7042Z-E1	AZ7042Z	AZ7042Z-E1	Bulk
			AZ7042ZTR	AZ7042ZTR-E1	AZ7042Z	AZ7042Z-E1	Ammo
		4.5V	AZ7045Z	AZ7045Z-E1	AZ7045Z	AZ7045Z-E1	Bulk
			AZ7045ZTR	AZ7045ZTR-E1	AZ7045Z	AZ7045Z-E1	Ammo
SOT-89-3	-40 to 85°C	2.3V	AZ7023RTR	AZ7023RTR-E1	7023R	E723	Tape & Reel
		2.5V	AZ7025RTR	AZ7025RTR-E1	7025R	E725	Tape & Reel
		2.7V	AZ7027RTR	AZ7027RTR-E1	7027R	E727	Tape & Reel
		2.9V	AZ7029RTR	AZ7029RTR-E1	7029R	E729	Tape & Reel
		3.1V	AZ7031RTR	AZ7031RTR-E1	7031R	E731	Tape & Reel
		3.3V	AZ7033RTR	AZ7033RTR-E1	7033R	E733	Tape & Reel
		4.2V	AZ7042RTR	AZ7042RTR-E1	7042R	E742	Tape & Reel
		4.5V	AZ7045RTR	AZ7045RTR-E1	7045R	E745	Tape & Reel

BCD Semiconductor's Pb-free products, as designated with "E1" suffix in the part number, are RoHS compliant.

**VOLTAGE DETECTOR****AZ70XX****Absolute Maximum Ratings (Note 1)**

Parameter	Symbol	Min	Max	Unit
Supply Voltage	V_{CC}	-0.3	18	V
Power Dissipation (Package Limitations)	P_D	TO-92 Package: 500		mW
		SOT-89-3 Package: 400		
Storage Temperature Range	T_{STG}	-65	150	°C
ESD (Machine Model)	ESD		500	V
ESD (Human Body Mode)	ESD		5000	V

Note 1: Stresses greater than those listed under "Absolute Maximum Ratings" may cause permanent damage to the device. These are stress ratings only, and functional operation of the device at these or any other conditions beyond those indicated under "Recommended Operating Conditions" is not implied. Exposure to "Absolute Maximum Ratings" for extended periods may affect device reliability.

Recommended Operating Conditions

Parameter	Symbol	Min	Max	Unit
Supply Voltage	V_{CC}		15	V
Operating Temperature Range	T_{OPR}	-40	85	°C



VOLTAGE DETECTOR **AZ70XX**

Electrical Characteristics

Operating Conditions: $T_A=25^{\circ}\text{C}$ unless otherwise specified.

Parameter	Symbol	Conditions	Min	Typ	Max	Unit	
Detecting Voltage	V_S	$R_L=200\Omega$ (Note 2) $V_{OL} \leq 0.4\text{V}$	AZ7023R/Z	2.15	2.3	2.45	V
			AZ7025R/Z	2.35	2.5	2.65	
			AZ7027R/Z	2.55	2.7	2.85	
			AZ7029R/Z	2.75	2.9	3.05	
			AZ7031R/Z	2.95	3.1	3.25	
			AZ7033R/Z	3.15	3.3	3.45	
			AZ7042R/Z	4.05	4.2	4.35	
AZ7045R/Z	4.35	4.5	4.65				
Low-Level Output Voltage	V_{OL}	$V_{CC}=V_S(\text{min})-0.05\text{V}$ $R_L=200\Omega$ (Note 2)			0.4	V	
Output Leakage Current	I_{OH}	$V_{CC}=15\text{V}$			0.1	μA	
Hysteresis Voltage	V_{HYS}	$R_L=200\Omega$ (Note 2)	30	50	100	mV	
Detect Voltage Temperature Coefficient	$\Delta V_S/(V_S \times \Delta T)$	$R_L=200\Omega$ (Note 2)		± 0.01		% / $^{\circ}\text{C}$	
Circuit Current at On Time	I_{CCL}	$V_{CC}=V_S(\text{min})-0.05\text{V}$		300	500	μA	
Circuit Current at Off Time	I_{CCH}	$V_{CC}=5.25\text{V}$		30	50	μA	
Minimum Operating Voltage	V_{OPR}	$R_L=200\Omega$ (Note 2) $V_{OL} \leq 0.4\text{V}$		0.8		V	
“L” Transmission Delay Time	tp_{HL}	V_{CC} changed from 5.25V to $V_S(\text{min})-0.05\text{V}$, $R_L=1.0\text{K}\Omega$, $C_L=100\text{p}$ (Note 3)		10		μs	
“H” Transmission Delay Time	tp_{LH}	V_{CC} changed from $V_S(\text{min})-0.05\text{V}$ to 5.25V, $R_L=1.0\text{K}\Omega$, $C_L=100\text{p}$ (Note 3)		15		μs	
Output Current at On Time	$I_{OL I}$	$V_{CC}=V_S(\text{min})-0.05\text{V}$ $T_A=25^{\circ}\text{C}$ (Note 4)	20			mA	
	$I_{OL II}$	$V_{CC}=V_S(\text{min})-0.05\text{V}$ $T_A=-40$ to 85°C (Note 4)	16				

Note 2: See test circuit 1 and Figure 12.

Note 3: See test circuit 2 and Figure 12.

Note 4: See test circuit 3. Adjusting the regulative power source until the reading value of voltage meter V is 0.4V, the reading value of current meter A is defined as "Output Current at On Time".



VOLTAGE DETECTOR

AZ70XX

Electrical Characteristics (Continued)

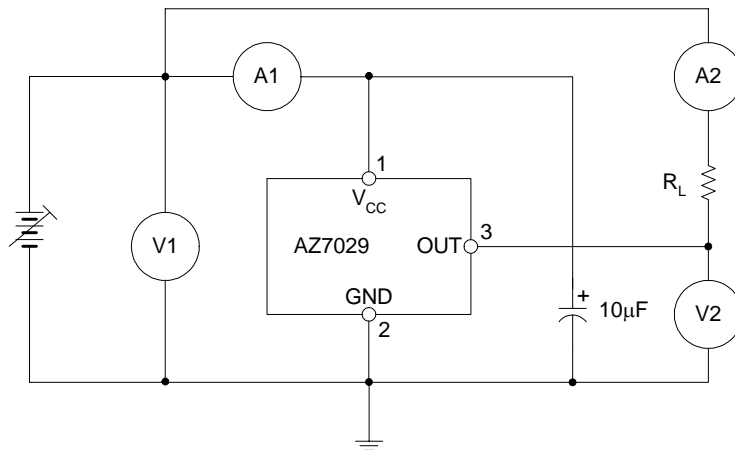

Figure 4. Test Circuit 1

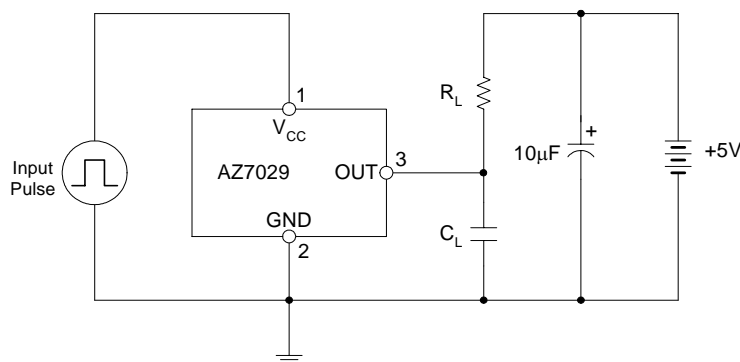

Figure 5. Test Circuit 2

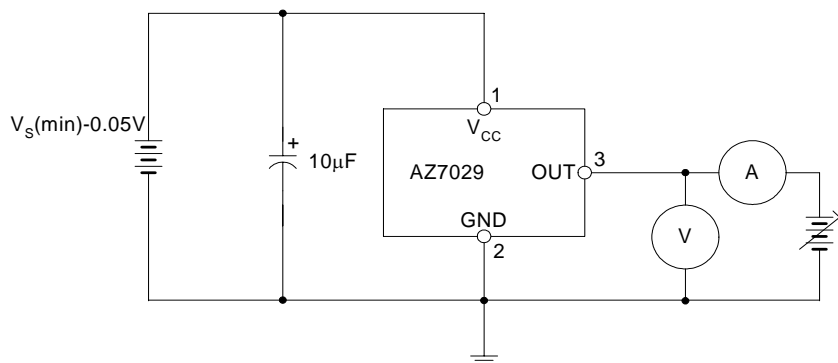

Figure 6. Test Circuit 3



VOLTAGE DETECTOR

AZ70XX

Typical Performance Characteristics

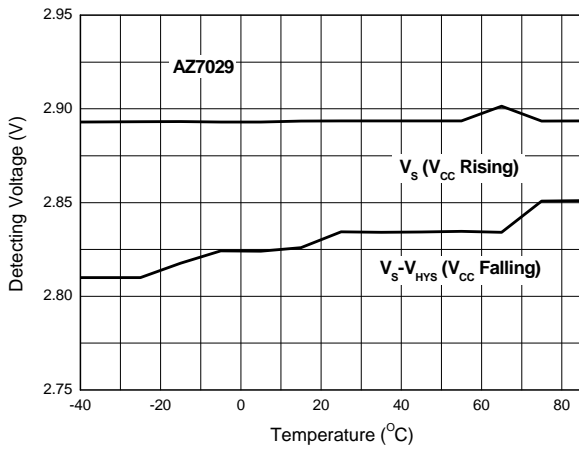

Figure 7. Detecting Voltage vs. Temperature

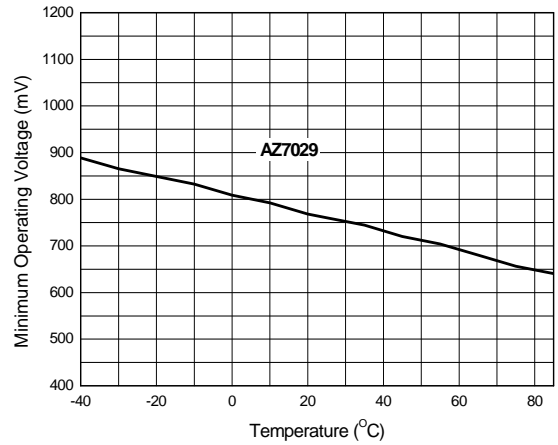

Figure 8. Minimum Operating Voltage vs. Temperature

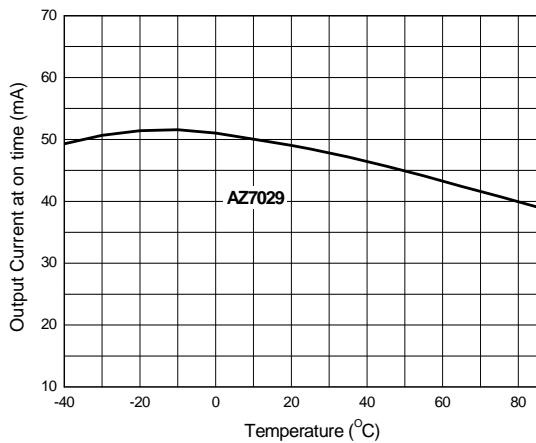

Figure 9. Output Current at on Time vs. Temperature

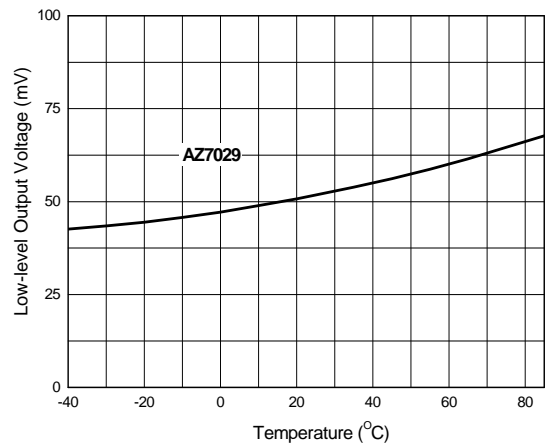

Figure 10. Low-level Output Voltage vs. Temperature



VOLTAGE DETECTOR

AZ70XX

Typical Performance Characteristics (Continued)

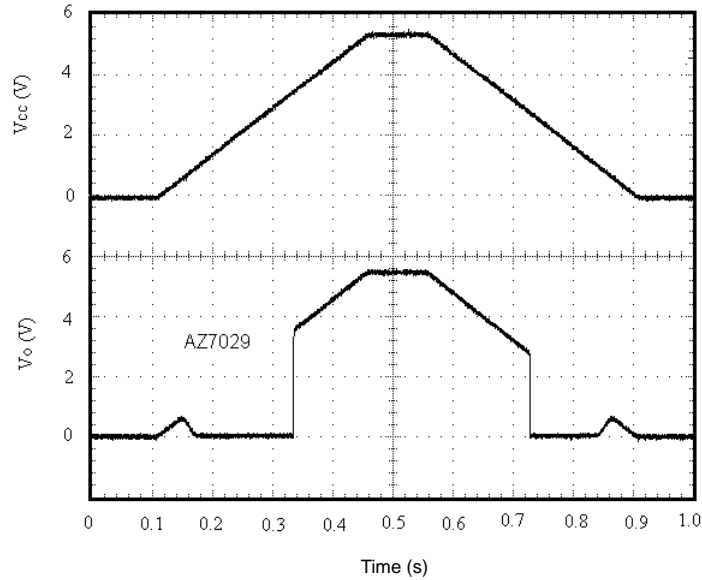

Figure 11. Output Voltage Dynamic Response when V_{CC} Increases and Decreases

Operating Diagram

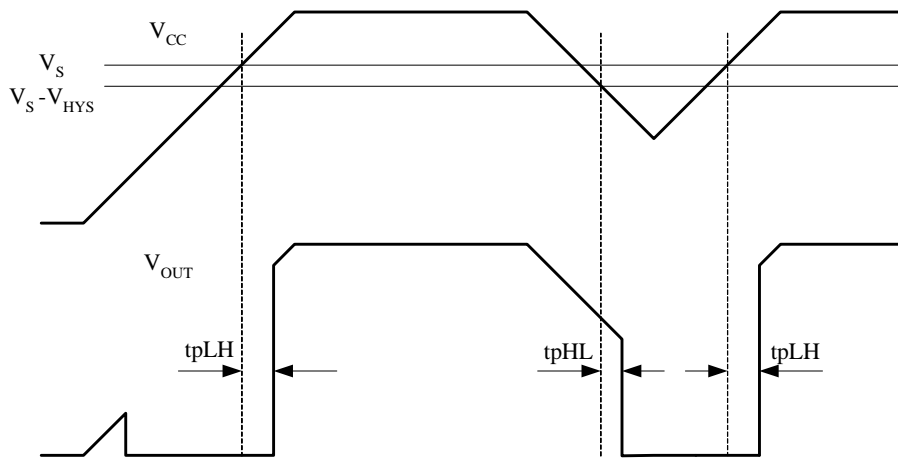

Figure 12. AZ70XX Timing Waveform



VOLTAGE DETECTOR

AZ70XX

Operating Diagram (Continued)

Figure 12 is a typical timing waveform for AZ70XX during power-up and temporary power-down period. Here is some explanations for AZ70XX's operation.

1. During power-up period, V_{OUT} will remain undefined until V_{CC} rises above V_{OPR} (typically 0.8V). After that moment, the output will become valid and will be at its logic low state while $V_{OPR} < V_{CC} < V_S$ for power-up operating.
2. After a delay time of tp_{LH} from the moment $V_{CC} > V_S$, the V_{OUT} will be at its logic high state. In general, V_{OUT} is dependent upon the voltage that the pull up resistor connected to.

3. During power-down, after a delay time of tp_{HL} from the moment $V_{CC} < V_S - V_{HYS}$, V_{OUT} will be at its logic low state. In general, at rated output current and V_{CC} , V_{OUT} can be pulled down to a voltage as low as within 0.4V from GND. (See the Electrical Characteristics section).

4. V_{OUT} will be at its logic low state while $V_S - V_{HYS} > V_{CC} > V_{OPR}$ for power-down operating.
5. After V_{CC} falls below V_{OPR} , the output is undefined.

Typical Applications

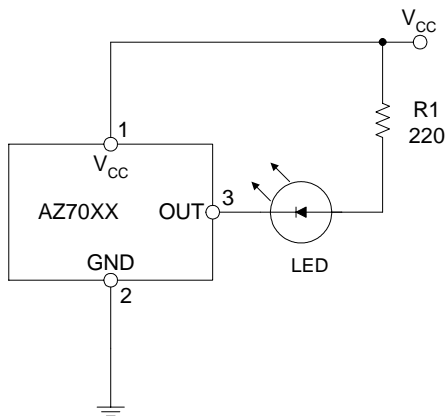

Figure 13. Low Voltage Indicator

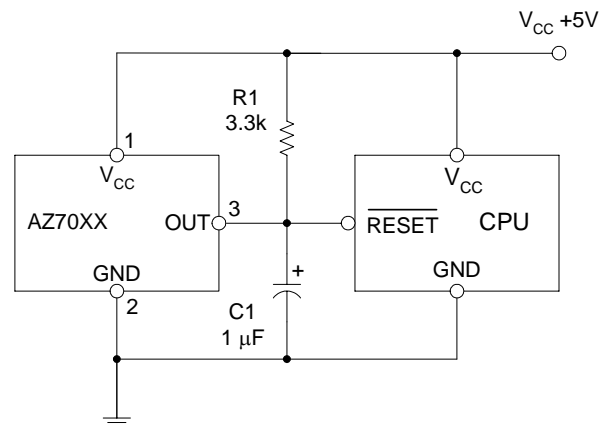

Figure 14. CPU Resetting Circuit



VOLTAGE DETECTOR

AZ70XX

Mechanical Dimensions

TO-92

Unit: mm (inch)

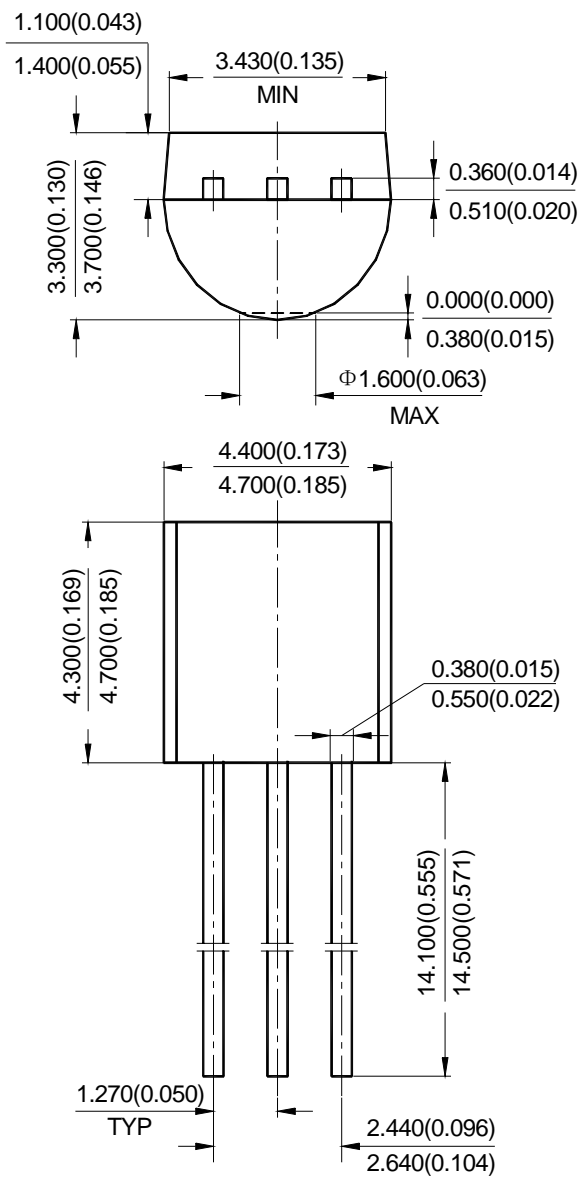



VOLTAGE DETECTOR

AZ70XX

Mechanical Dimensions (Continued)

SOT-89-3

Unit: mm(inch)

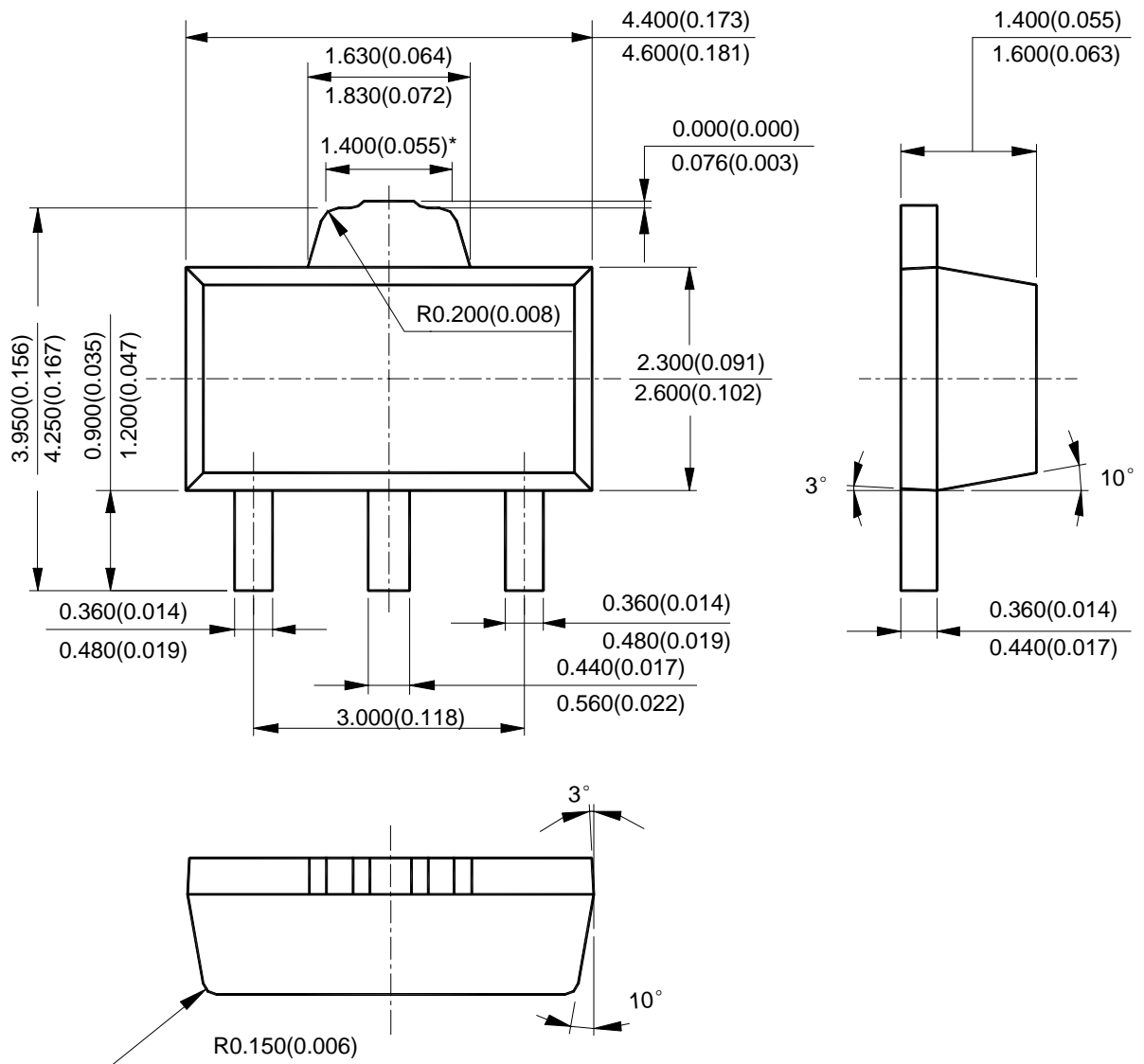



BCD Semiconductor Manufacturing Limited

<http://www.bcdsemi.com>

BCD Semiconductor Corporation

3170 De La Cruz Blvd, Suite # 105 Santa Clara, CA 95054-2411, U.S.A

Tel: +1-408-988 6388, Fax: +1-408-988 6386

Shanghai SIM-BCD Semiconductor Manufacturing Co., Ltd.

800 Yi Shan Road, Shanghai 200233, PRC

Tel: +86-21-6485 1491, Fax: +86-21-5450 0008

Advanced Analog Circuits (Shanghai) Corporation

8F, B Zone, 900 Yi Shan Road, Shanghai 200233, PRC

Tel: +86-21-6495 9539, Fax: +86-21-6485 9673

BCD Semiconductor (Taiwan) Company Limited

4F, 298-1 Rui Guang Road, Nei-Hu District, Taipei, Taiwan

Tel: +886-2-2656-2808, Fax: +886-2-2656-2806

IMPORTANT NOTICE

BCD Semiconductor Manufacturing Limited reserves the right to make changes without further notice to any products or specifications herein. BCD Semiconductor Manufacturing Limited does not assume any responsibility for use of any its products for any particular purpose, nor does BCD Semiconductor Manufacturing Limited assume any liability arising out of the application or use of any its products or circuits. BCD Semiconductor Manufacturing Limited does not convey any license under its patent rights or other rights nor the rights of others.