



SC310 High-Side Current-Sense Amplifier with Low Impedance Voltage Output

POWER MANAGEMENT

Description

The SC310 is a high-side current sense amplifier ideal for any application where precision current monitoring is needed. Possible uses include battery-powered products such as cellphones and notebooks, as well as industrial and data acquisition applications. The wide 2.7V to 25V common mode input range is independent of supply range, providing complete flexibility in battery sensing applications.

The Current-Sense Amplifier offers three gain versions, SC310A (gain 20 V/V), SC310B (gain 50 V/V) and SC310C (gain 100 V/V). An external shutdown pin (SHDN) enables turn off for the IC. A buffered output with low impedance renders the overall gain immune to load resistance. Output range is from 0V to $V_{CC} - 1.7V$.

Other features include tiny SOT-23-6 packaging, very low supply current, and wide supply voltage range (3V to 25V). The SC310 is rated for operation over the Industrial Temperature range (-40°C to +125°C).

Features

- ◆ Three gain versions (20V/V, 50V/V, 100V/V) available
- ◆ 2.7V to 25V input common mode range
- ◆ 3V to 25V supply voltage range
- ◆ 270 μA supply current
- ◆ 1% typical accuracy
- ◆ Buffered low impedance voltage output
- ◆ Industrial temperature range (-40°C to +125°C)
- ◆ Small, lead-free SOT23-6 Package

Applications

- ◆ Notebook and Tablet PCs
- ◆ Data Acquisition
- ◆ Battery Packs
- ◆ Charging Applications
- ◆ Industrial and Embedded Applications

Typical Application Circuit

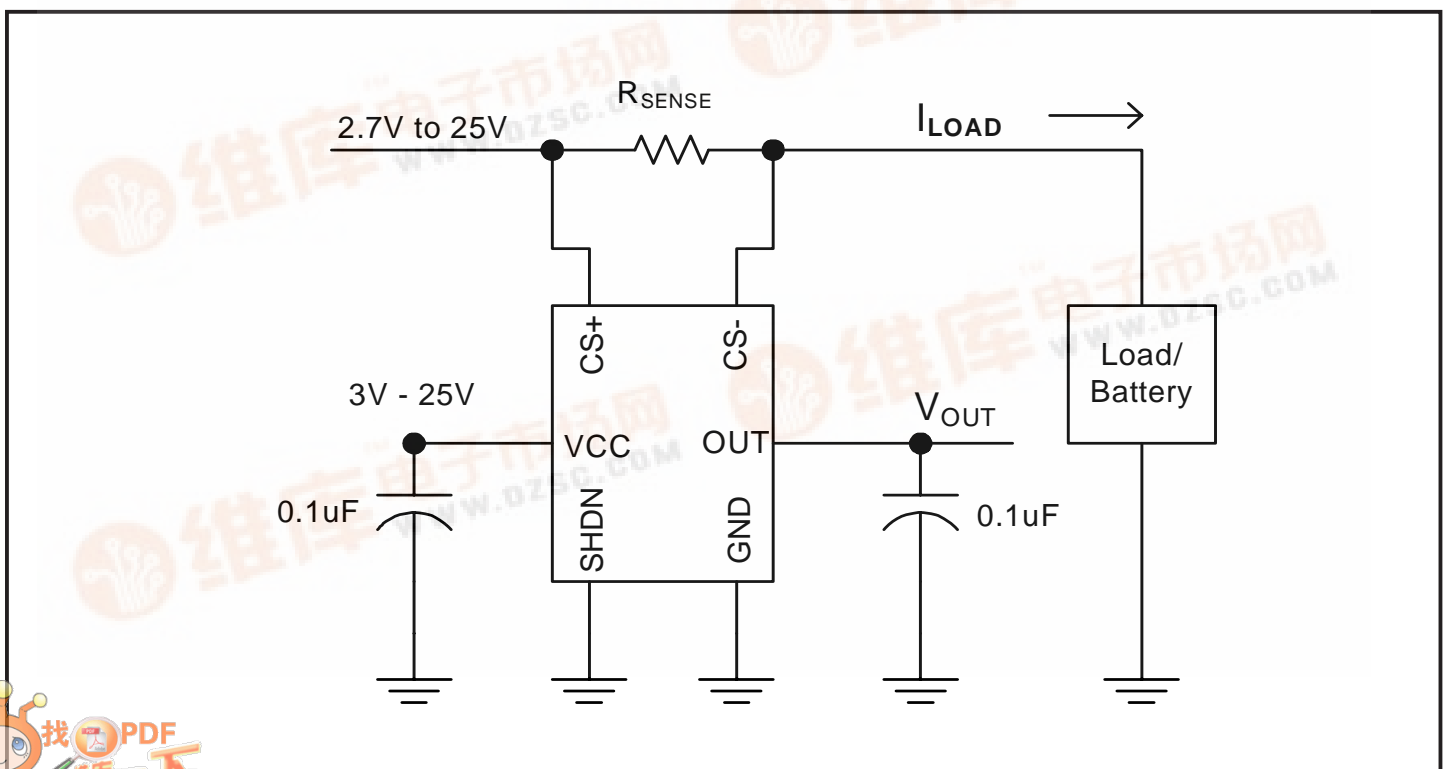

POWER MANAGEMENT
Absolute Maximum Ratings

Exceeding the specifications below may result in permanent damage to the device, or device malfunction. Operation outside of the parameters specified in the Electrical Characteristics section is not implied.

Parameter	Symbol	Min	Max	Units
Supply Voltage	V _{CC}	-0.3	28	V
Differential Input Voltage	V _{CS+} - V _{CS-}		0.5	V
Thermal Resistance Junction	θ _{JA}		230	°C/W
Thermal Resistance Junction to Case	θ _{JC}		81	°C/W
Operating Temperature Range	T _A	-40	+125	°C
Storage Temperature Range	T _{STG}	-65	+150	°C
Junction Temperature Range	T _J	-65	+150	°C
Lead Temperature (Soldering) 10s	T _{LEAD}		260	°C
CS+ Voltage	V _{CS+}	-0.3	V _{CC} + 0.3	V
CS- Voltage	V _{CS-}	-0.3	V _{CC} + 0.3	V
SHDN Voltage	V _{SHDN}	-0.3	V _{CC} + 0.3	V
ESD Rating (Human Body Model)	V _{ESD}		2	kV

Electrical Characteristics

V_{CS+} = 2.7V to 25V, V_{CC} = 3V to 25V, V_{SENSE} = 0, T_A = T_J = -40 °C to +125 °C, unless otherwise specified

Parameter	Symbol	Conditions	Min	Typ	Max	Units
Operating Voltage Range	V _{CC}		3		25	V
Common-Mode Input Range	V _{CMR}	0 °C ≤ T _A ≤ +125 °C	2.7		25	V
		-40 °C ≤ T _A < 0 °C	3		25	
Common-Mode Rejection	CMR			90		dB
Supply Current	I _{CC}	V _{CS+} > 2.7V, V _{CC} = 12V		0.27	1	mA
Input Bias Current	I _{CS+}	V _{CS+} > +2.7V		150		µA
	I _{CS-}	V _{CS+} > +2.7V	0		1	
Full-Scale Sense Voltage	V _{SENSE}	V _{SENSE} = V _{CS+} - V _{CS-}			150	mV
Total OUT Voltage Error		V _{SENSE} = +100mV, V _{CC} = 12V, V _{CS+} = 12V, -40 °C ≤ T _A ≤ 85 °C		1	4.25	%
		V _{SENSE} = +100mV, V _{CC} = 12V, V _{CS+} = 12V, T _A = 125 °C		1	4.5	
		V _{SENSE} = +100mV, V _{CC} = 12V, V _{CS+} = +12V, T _A = +25°		1	3.25	
		V _{SENSE} = +100mV, V _{CC} = 25V, V _{CS+} = 25V, -40 °C ≤ T _A ≤ 85 °C		1	4.5	

POWER MANAGEMENT
Electrical Characteristics (Cont.)
 $V_{CS+} = 2.7V$ to $25V$, $V_{CC} = 3V$ to $25V$, $V_{SENSE} = 0$, $T_A = T_J = -40^{\circ}C$ to $+125^{\circ}C$, unless otherwise specified

Parameter	Symbol	Conditions	Min	Typ	Max	Units
Total OUT Voltage Error		$V_{SENSE} = +100mV$, $V_{CC} = 25V$, $V_{CS+} = 25V$, $T_A = 125^{\circ}C$		1	4.75	%
		$V_{SENSE} = +6.25mV$, $V_{CC} = 12V$, $V_{CS+} = 12V$, $-40^{\circ}C \leq T_A \leq 125^{\circ}C$		+/- 7.5		
OUT High Voltage	$V_{CC} - V_{OH}$	$-5^{\circ}C \leq T_A \leq +125^{\circ}C$			1.7	V
3dB Bandwidth	BW	SC310A, $V_{SENSE} = +100mV$		2		
		SC310B, $V_{SENSE} = +100mV$		1.4		MHz
		SC310C, $V_{SENSE} = +100mV$		0.9		
GAIN	A_V	SC310A		20		V/V
		SC310B		50		
		SC310C		100		
Gain Accuracy		$V_{SENSE} = +100mV$, SC310A/B/C			4.0	%
OUT Output Resistance ⁽¹⁾	R_{OUT}	$V_{SENSE} = +16mV$		60		Ω
Power-Supply Rejection	PSRR	$V_{SENSE} = 16mV$ $V_{CS+} > +2.7V$	60	70		dB
OUT Settling Time to 1% of the Final Value		$V_{CC} = +12V$ $V_{CS+} = +12V$ $C_{LOAD} = 5pF$ $V_{SENSE} = +6.25mV$ to $+100mV$		2		μS
		$V_{SENSE} = +100mV$ to $+6.25mV$		2		
Power-Up Time to 1% of the Final Value ⁽²⁾		$V_{SENSE} = +100 mV$, $C_{LOAD} = 5pF, V_{CC} = +12V$ $V_{CS+} = +12V$		50		μS
Input bias current for SHDN	I_{SHDN}	$V_{SHDN} = +5V$			7	μA
V_{SHDN} Threshold (device on)	$V_{SHDN_TH_ON}$	$3V \leq V_{CC} \leq 25V$			350	mV
V_{SHDN} Threshold (device off)	$V_{SHDN_TH_OFF}$	$3V \leq V_{CC} \leq 25V$	2			V
Supply Current for SHDN	I_{CC}	$V_{CC} = 12V$, $V_{SHDN} = +5V$		11		μA

Note (1): SC310 has a low impedance output. However the maximum output drive capability is limited to 500uA

 Note (2): Defined with respect to Shutdown signal. Time taken for output to go high as V_{SHDN} switches from 5V to 0V

POWER MANAGEMENT

Pin Configuration

Ordering Information

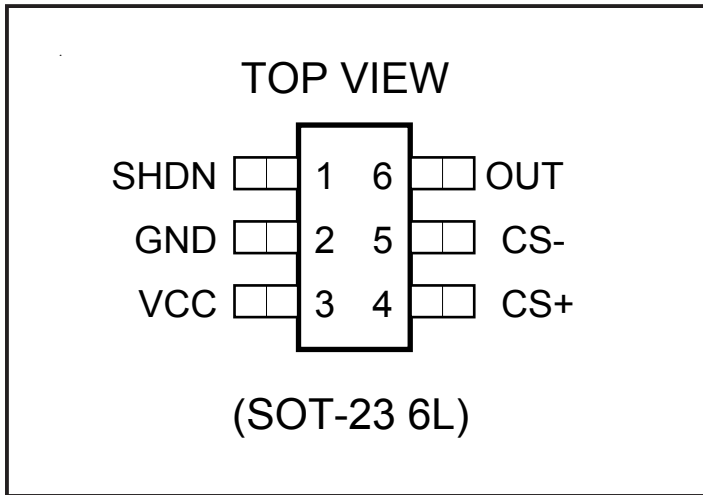

Device ⁽¹⁾ ⁽²⁾ ⁽³⁾	Package
SC310XSKTRT	SOT-23-6
SC310XEVB	Evaluation Board

Notes:

- (1) Where X denotes Gain options. Available Gains are: 20 V/V (A), 50 V/V (B), 100 V/V (C). Contact factory for additional voltage options.
- (2) Only available in tape and reel packaging. A reel contains 3000 devices.
- (3) This lead-free device is fully RoHS and WEEE compliant.

Pin Descriptions

SC310A, gain = 20 V/V
 SC310B, gain = 50 V/V
 SC310C, gain = 100 V/V

Pin	Name	Function
1	SHDN	Connect to GND to enable the IC
2	GND	Ground
3	VCC	Supply Voltage Input, bypass to ground with a 0.1µF capacitor
4	CS+	Power side connection to external sense resistor
5	CS-	Load side connection for the external sense resistor
6	OUT	Voltage output, V_{OUT} is proportional to V_{SENSE} ($V_{CS+} - V_{CS-}$)

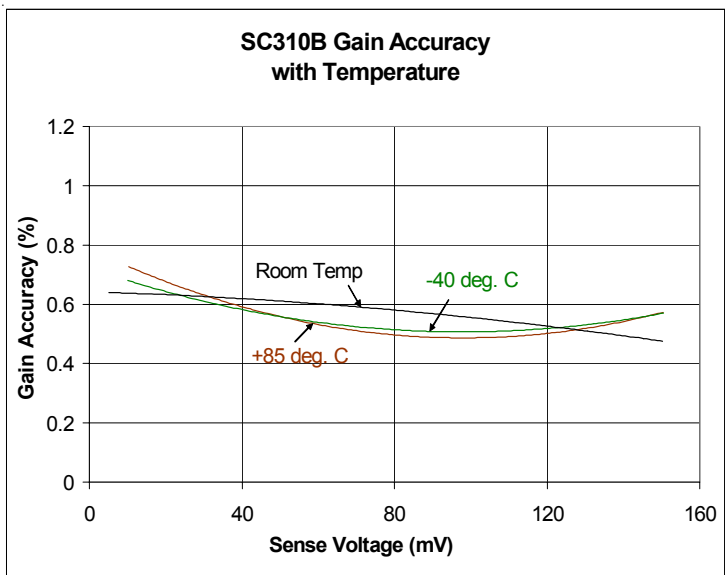
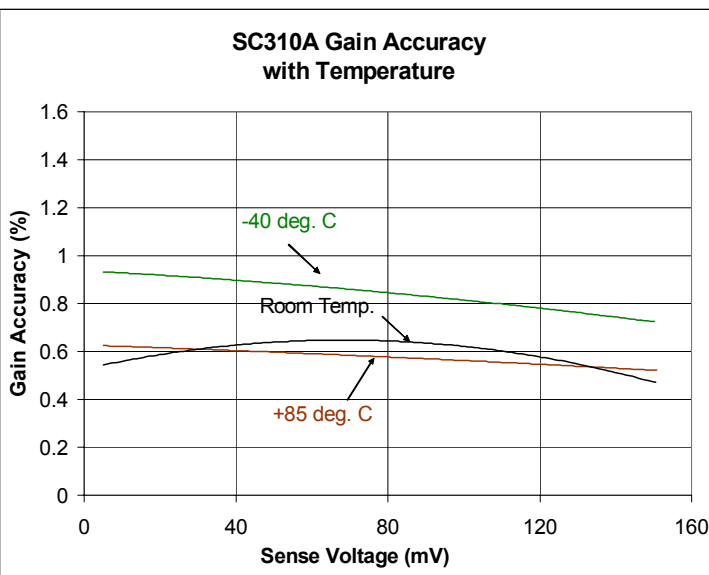
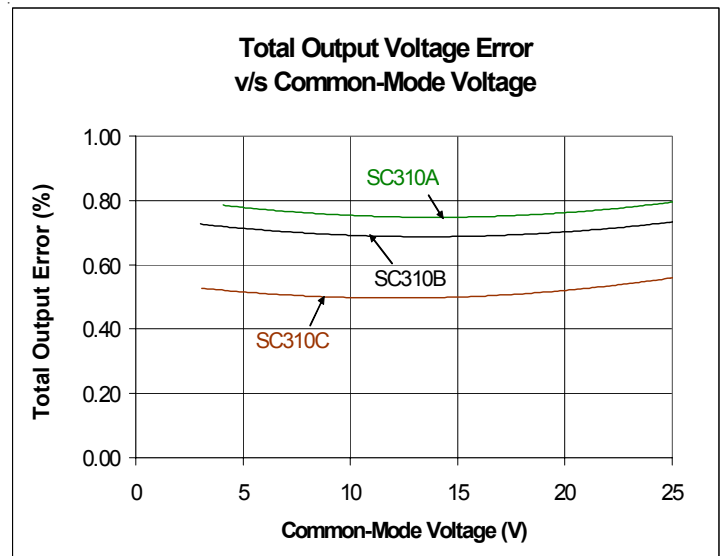
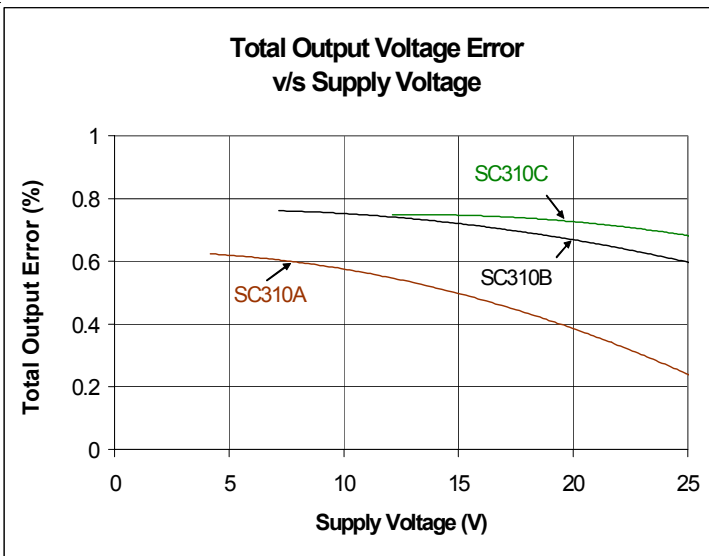
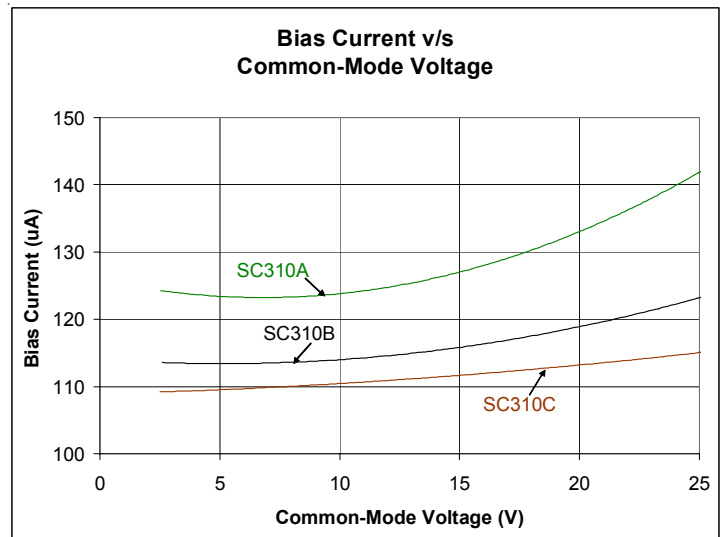
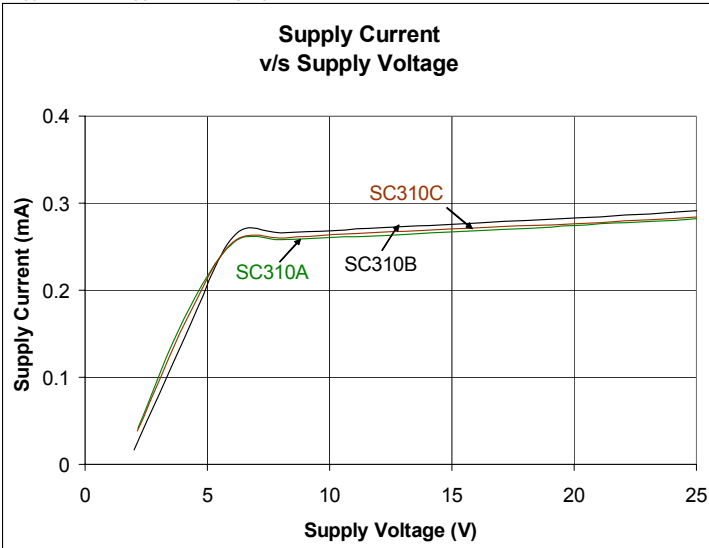
POWER MANAGEMENT
Electrical Characteristics
 $V_{CS+} = 12V, V_{CC} = 12V, V_{SENSE} = 100mV, T_A = 25^{\circ}C$, unless otherwise specified

POWER MANAGEMENT

Electrical Characteristics

$V_{CS+} = 12V$, $V_{CC} = 12V$, $V_{SENSE} = 100mV$, $T_A = 25^\circ C$, unless otherwise specified

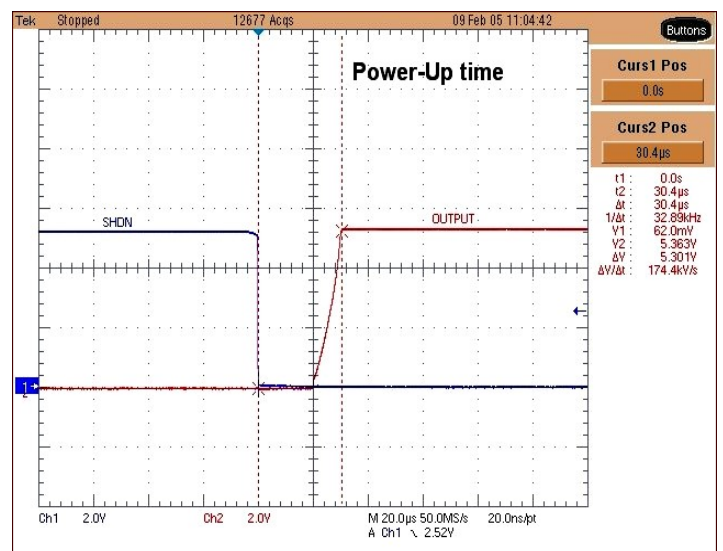
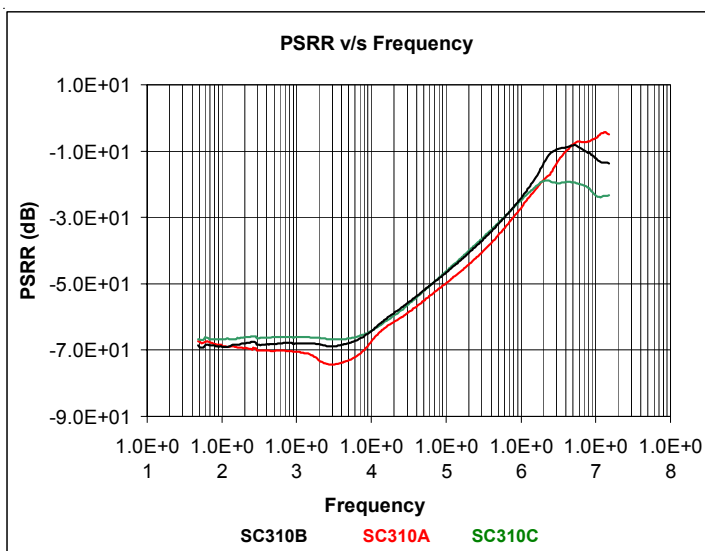
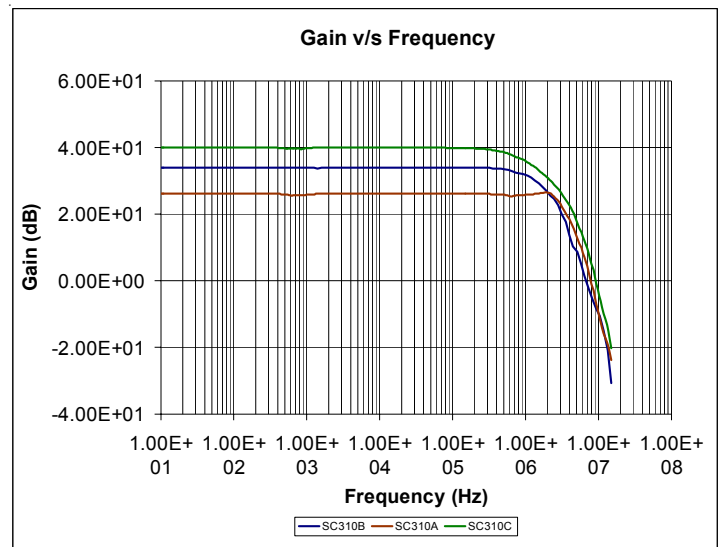
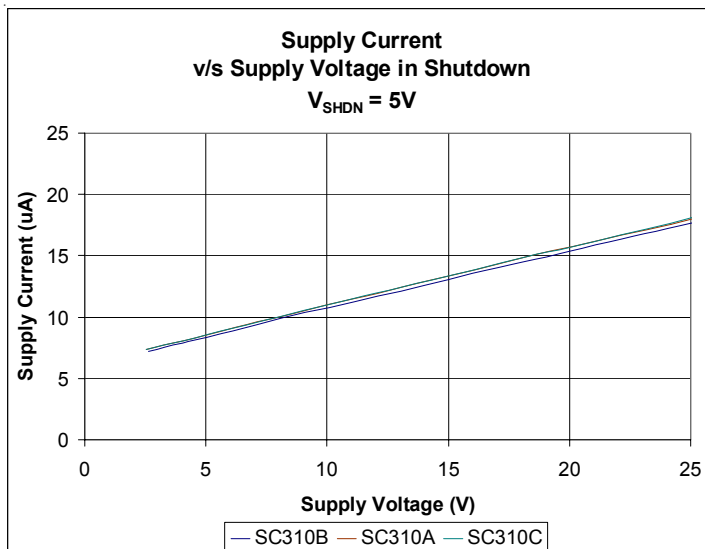
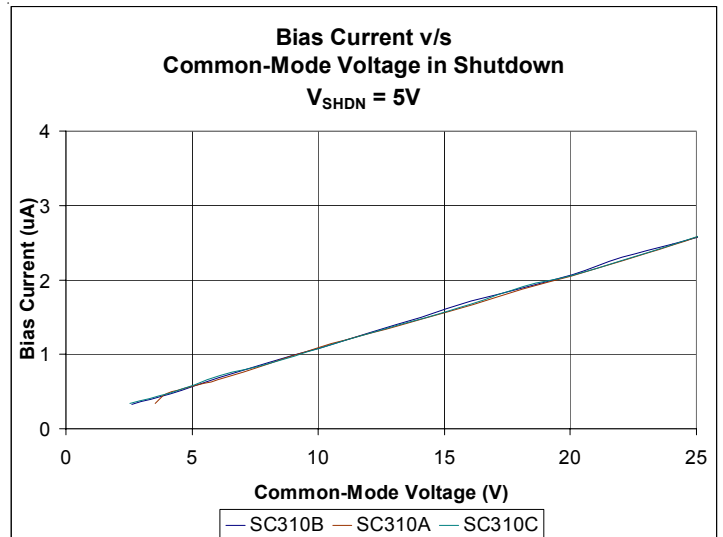
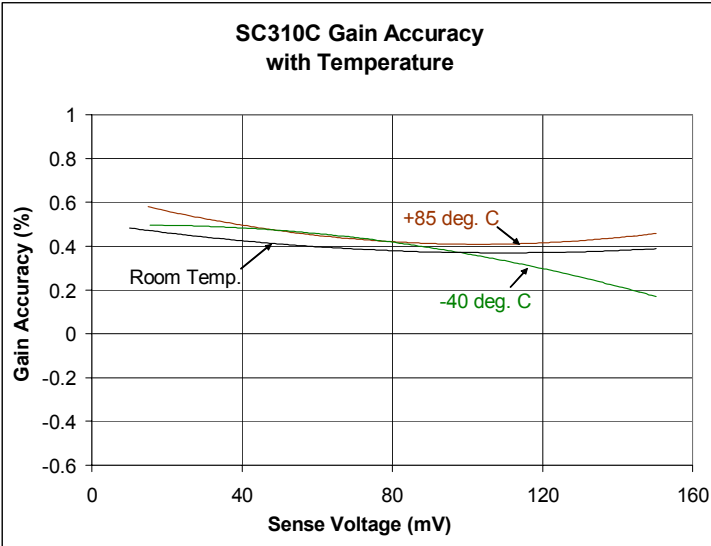

POWER MANAGEMENT

Electrical Characteristics (Cont.)

$V_{CS+} = 12V, V_{CC} = 12V, V_{SENSE} = 100mV, T_A = 25^{\circ}C$, unless otherwise specified

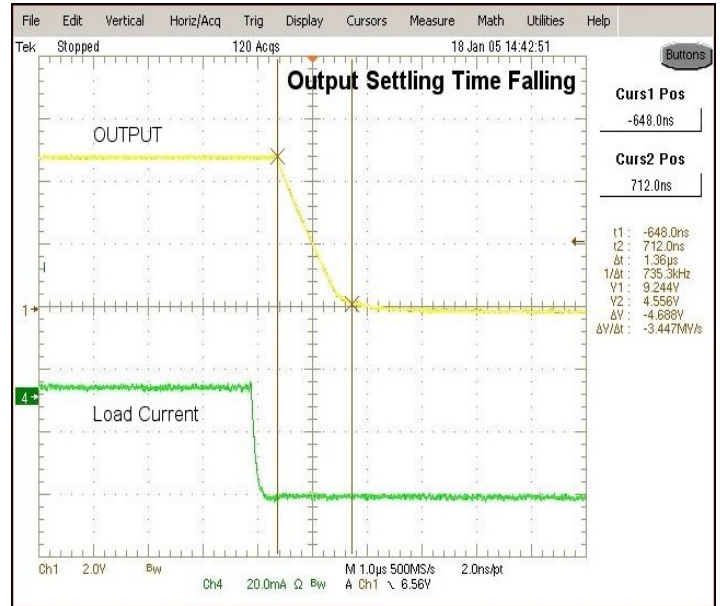

POWER MANAGEMENT

Block Diagram

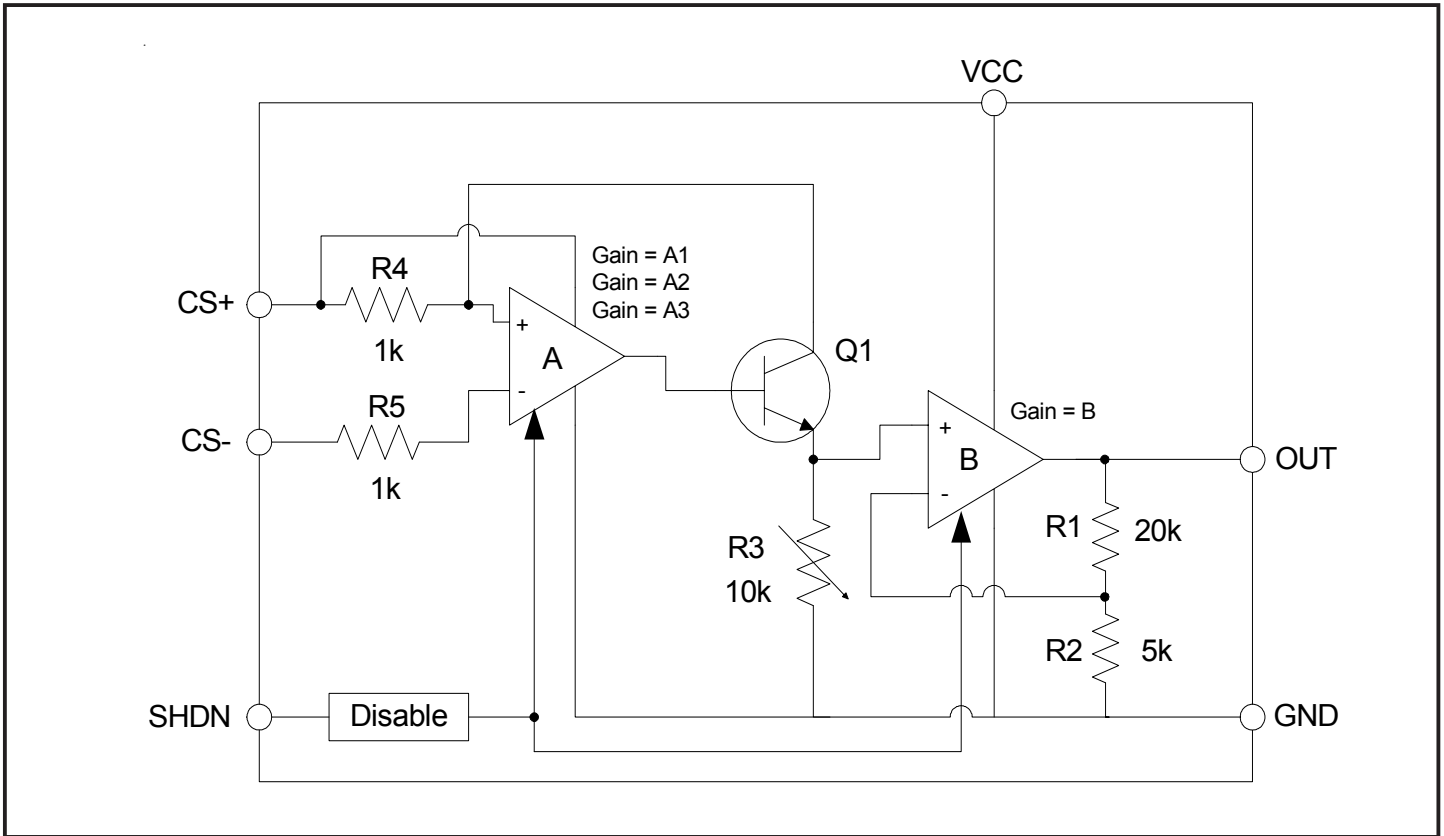

Detailed Description

SC310 is a unidirectional high-side current sense amplifier for precision current monitoring. It has a wide common-mode range of 2.7 to 25V and allows high-side current-sensing at voltages greater than supply voltage (V_{CC}).

The SC310 operates as follows: Current from source (as shown in the typical applications circuit on page. 1), flows through RSENSE to the load. Since the inverting input of amplifier A has a high input impedance, negligible current flows through R5 (neglecting the input bias current). Amplifier A has an inverting input voltage which equals $V(CS+) - I_{LOAD} * R_{SENSE}$. The amplifier's high open-loop gain forces the non-inverting input voltage to the same voltage as the inverting input. The drop across R4 equals $I_{LOAD} * R_{SENSE}$. Since I_{R4} flows through R4, $I_{R4} = (I_{LOAD} * R_{SENSE}) / R4$. Resistor R3 then sets the overall gain for amplifier A, A1, A2 or A3 (neglecting the input bias currents for non-inverting inputs for amplifiers A and B). The second amplifier, B, is a fixed gain stage (gain = B) and the final output includes the gain obtained from this stage.

The SC310 has three gain versions as follows:

Version	Gain Expression	Gain Value
SC310A	$A1 * B$	20
SC310B	$A2 * B$	50
SC310C	$A3 * B$	100

POWER MANAGEMENT

Application Information

Choosing R_{sense}

Full scale sense voltage for the amplifier is 150mV max. The resistor (R_{sense}) is selected depending on the load of the system. For light loads a bigger value of R_{sense} is selected to minimize the error in the proportional output voltage. Higher resistor value improves the strength of the signal at the current-sense amplifier input and hence gives an accurate output.

The voltage at the OUT pin of the amplifier is given as:

$$V_{out} = (\text{Gain}) * (I_{load}) * (R_{sense})$$

Similarly, for heavy loads, a smaller value of R_{sense} resistor is used not to exceed the max “Sense Voltage” rating of the IC. Also at high loads, a power rating of R_{sense} resistor is used and must be acceptable (greater than I^2R power dissipation in the resistor).

PCB trace can also be used as the sense resistor. This has the drawback of significant error at the output over temperature. The trade-off, despite the error in the output voltage, provides for a cost-effective solution.

SHDN Function

The SHDN pin should not be kept floating and must be tied to either ground or be held high. Connecting the pin to ground is needed for normal operation. The voltage level at the SHDN pin is independent of the functioning of the IC.

Typical Values for Sense Resistors

Table 1. lists the common resistor values for typical operation of the SC310. SC310 is capable of sensing wide ranges of currents providing proper sense resistors are used.

Output Impedance

The output impedance of the SC310 is very low. Typical value is 60Ω. Connecting the OUT pin to a high-impedance input stage is recommended. Resistive loading on the OUT pin will not affect the gain of the SC310.

Common Mode Input

The sense voltage is limited at low values of common mode input voltage (V_{CMR}). The figure below specifies the desired sense voltage for low common mode input voltage. In the figure below we see that SC310A can be operated over full-scale sense voltage at $V_{cs+} = 2.7V$, whereas the voltage is limited for SC310B and SC310C.

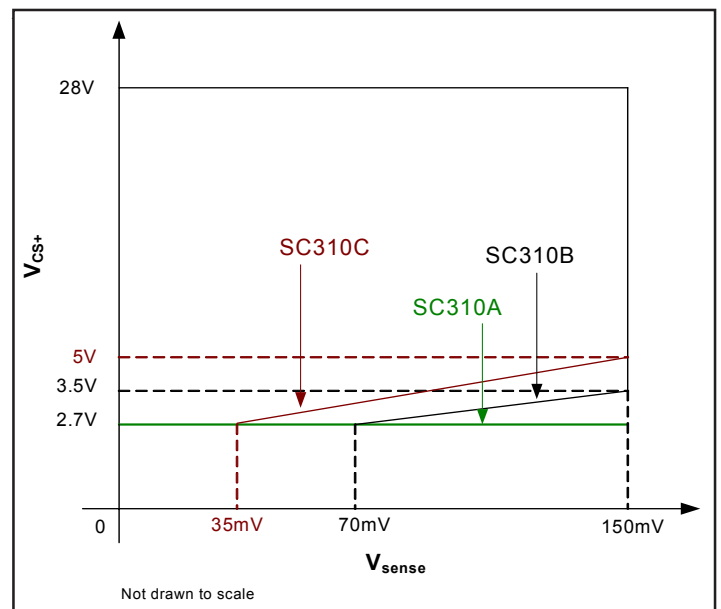

Layout Guidelines

1. Place the SC310 between the pins and external circuitry to reduce the trace length.
2. Place the decoupling capacitor at the input (V_{CC}) as close as possible to the pin.
3. An R-C filter at the input will help achieve the highest noise rejection.
4. Run the traces from R_{sense} as close as possible. Use minimum width traces to reduce capacitive coupling.

POWER MANAGEMENT
Table 1. Recommended Component Values

Full-Scale Load Current I_{LOAD} (A)	Current Sense Resistor R_{sense} (m Ω)	Gain	Full-Scale Output Voltage (Full-Scale $V_{sense} = 100\text{mV}$) V_{out} (V)
0.1	1000	20	2.0
		50	5.0
		100	10.0
1	100	20	2.0
		50	5.0
		100	10.0
2	50	20	2.0
		50	5.0
		100	10.0
5	20	20	2.0
		50	5.0
		100	10.0
10	10	20	2.0
		50	5.0
		100	10.0

POWER MANAGEMENT

Outline Drawing - SOT-23-6

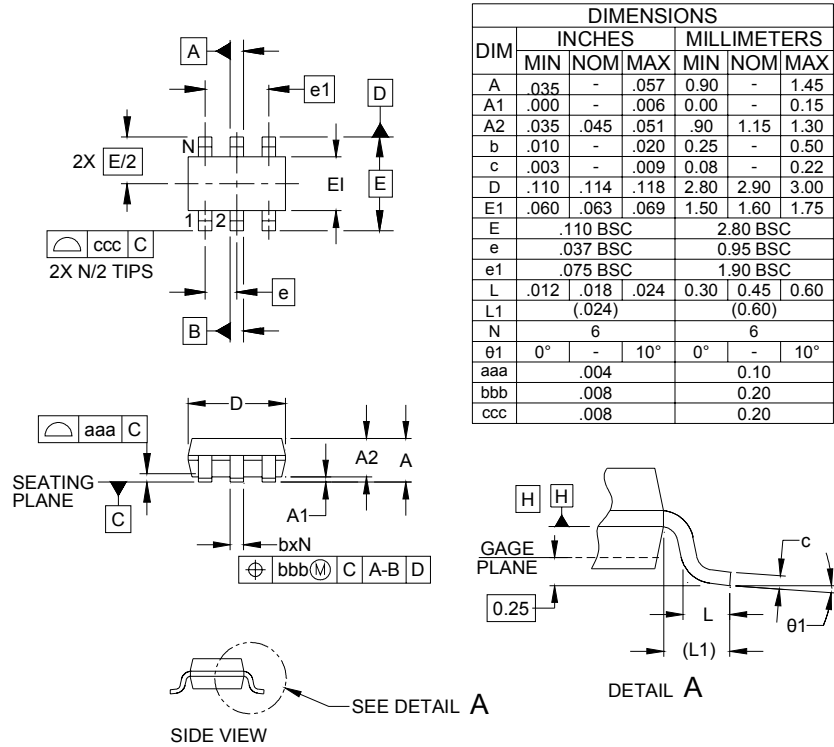

DIM	INCHES			MILLIMETERS		
	MIN	NOM	MAX	MIN	NOM	MAX
A	.035	-	.057	0.90	-	1.45
A1	.000	-	.006	0.00	-	0.15
A2	.035	.045	.051	.90	1.15	1.30
b	.010	-	.020	0.25	-	0.50
c	.003	-	.009	0.08	-	0.22
D	.110	.114	.118	2.80	2.90	3.00
E1	.060	.063	.069	1.50	1.60	1.75
E	.110 BSC			2.80 BSC		
e	.037 BSC			0.95 BSC		
e1	.075 BSC			1.90 BSC		
L	.012	.018	.024	0.30	0.45	0.60
L1	(0.024)			(0.60)		
N	6			6		
θ1	0°	-	10°	0°	-	10°
aaa	.004			0.10		
bbb	.008			0.20		
ccc	.008			0.20		

- NOTES:
1. CONTROLLING DIMENSIONS ARE IN MILLIMETERS (ANGLES IN DEGREES).
 2. DATUMS **-A-** AND **-B-** TO BE DETERMINED AT DATUM PLANE **-H-**
 3. DIMENSIONS "E1" AND "D" DO NOT INCLUDE MOLD FLASH, PROTRUSIONS OR GATE BURRS.

Land Pattern - SOT-23-6

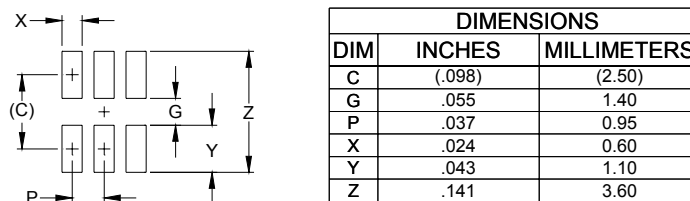

DIM	DIMENSIONS	
	INCHES	MILLIMETERS
C	(.098)	(2.50)
G	.055	1.40
P	.037	0.95
X	.024	0.60
Y	.043	1.10
Z	.141	3.60

- NOTES:
1. THIS LAND PATTERN IS FOR REFERENCE PURPOSES ONLY. CONSULT YOUR MANUFACTURING GROUP TO ENSURE YOUR COMPANY'S MANUFACTURING GUIDELINES ARE MET.



SC310

POWER MANAGEMENT

NOTES

Contact Information

Semtech Corporation
Power Management Products Division
200 Flynn Road, Camarillo, CA 93012
Phone: (805) 498-2111 FAX (805)498-3804

Visit us at: www.semtech.com