

PLAYBACK / RECORD IC
WITH VOICE-CHANGER FUNCTION

Features

- Operating voltage range: 3.3V - 5.0V
- Connected with an external capacitor (Cup), the operating voltage can be improve to 6.4V.
- ADPCM voice recording & playback
- Recording length: 3 seconds (Based on 6K sample rate)
- Several selectable voice effects (transposing voice, robotic voice, original voice)
- Manual control or talk-back mode options are available for recording.
- Built-in voice-recording mic-amplifier
- CNT1 signal drives LED during the recording state
- CNT2 signal drives LED during the playback state
- Low Stand-by current in power OFF mode

General Description

RTS0073 is a CMOS designed with recording and playback function and uses ADPCM technology to save voice DATA, while providing several voice synthesizers to achieve different voice effects (robotic, transposing, original). When the voice data is re-playing, RTS0073 has two modes to select from (manual and playback), and also has a built-in OP amplifier to amplify the input audio signal. In addition, RTS0073 provides CNT1 and CNT2 pins as recording/playing indicators, or to use for other purposes.

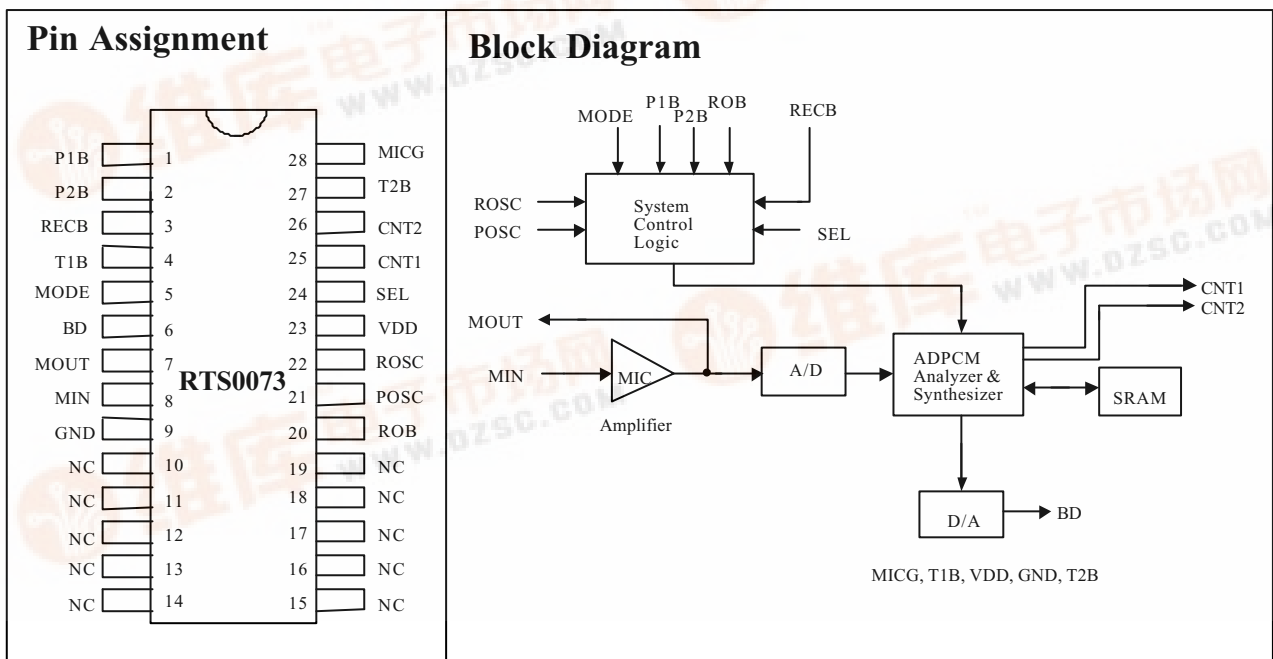

Absolute Maximum Ratings

DC Supply Voltage.....-0.3V to 6.0V
Input/Output Voltage.....GND -0.2V to VDD + 0.2V
Operating temperature.....-10°C to 60°C
Storage Temperature.....-25°C to 125°C

Comments*

Never allow a stress to exceed the values listed under "Absolute Maximum Ratings", otherwise the device would suffer from a permanent damage. Nor is a stress at the listed value be allowed to persist over a period, since an extended exposure to the absolute maximum rating condition may also affect the reliability of the device, if not causing a damage thereof.

Electrical Characteristics

(VDD=4.5V, T_A=25°C)

Parameter	Symbol	Min.	Typ.	Max.	Conditions
Operating Voltage	VDD	3.3V	4.5V	5.0V	
Operating Current (Record)	I _{DD}	-	-	6mA	Unload
Operating Current (Play back)		-	-	18mA	Unload
Stand-by Current	I _S	-	2μA	5μA	
CNT1 Driving Current	I _{C1}	6mA	-	-	V _{oh} = 1.8V
CNT2 Driving Current	I _{C2}	6mA	-	-	V _{oh} = 1.8V
Output Current For Audio	I _A	3mA	-	-	
Frequency Stability	ΔF/F	-	-	5%	$\frac{F(4.5V)-F(4.0V)}{F(4.5V)} \times 100\%$
Frequency Variation	ΔF/F	-	-	15%	

Pin Description

Pin No.	Designation	Description						
1	P1B	In manual mode, pulling this pin low will initiate a play cycle. The chip will play the complete message. In talk-back mode, "P1B" is a useless pad. (internal pull high)						
2	P2B	In manual mode, pulling this pin low will play the recording data, and the recording data will be played continuously until this pin is pulled to high. In talk-back mode, "P2B" represents "number of repeating times" selection pin. Selection table is shown below: <table border="1" data-bbox="491 813 912 967"> <thead> <tr> <th>"P2B" pad</th> <th>Total times</th> </tr> </thead> <tbody> <tr> <td>Floating pad (internal pull high)</td> <td>1</td> </tr> <tr> <td>Low</td> <td>2</td> </tr> </tbody> </table>	"P2B" pad	Total times	Floating pad (internal pull high)	1	Low	2
"P2B" pad	Total times							
Floating pad (internal pull high)	1							
Low	2							
3	RECB	In manual mode, it will enter recording state when this pad is triggered. In talk-back mode, please reference to function description. (internal pull-high).						
4	T1B	Used for testing only						
5	MODE	Manual control mode or talk-back mode select pin						
6	BD	Audio output pin						
7	MOUT	Microphone amplifier output						
8	MIN	Microphone signal input pin						
9	GND	Negative power supply						
10 - 19	NC	No connection						
20	ROB	Robotic voice effect is selected when this pin connected to GND. Original voice (transposing voice) effect is selected when this pin is connected to VDD.						
21	POSC	Playback oscillator pin						
22	ROSC	Record oscillator pin						
23	VDD	Power supply						
24	SEL	The voice effects are adjusted by variable resistors when this pin is connected to GND. Original voice is selected when this pin is connected to VDD.						
25	CNT1	Indicate chip is busy processing speech data during recording (active high)						
26	CNT2	Indicate chip is busy processing speech data during playback (active high)						
27	T2B	Used for testing only						
28	MICG	N-channel open drain output. It will stay in "LOW" during the recording state.						

Function Description

(1) Manual control mode (MODE=GND)

A. When RECB pin goes from high to low \downarrow , RTS0073 begins recording until memory is full, then uses P1B or P2B pin to playback (P1B: one shot trigger, P2B: level hold trigger).

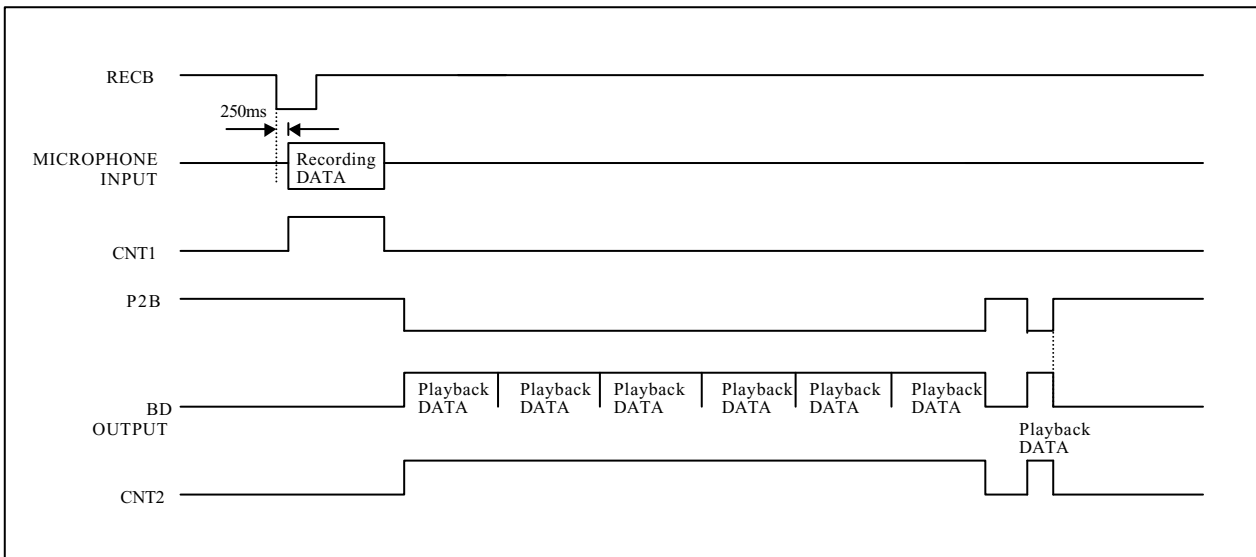
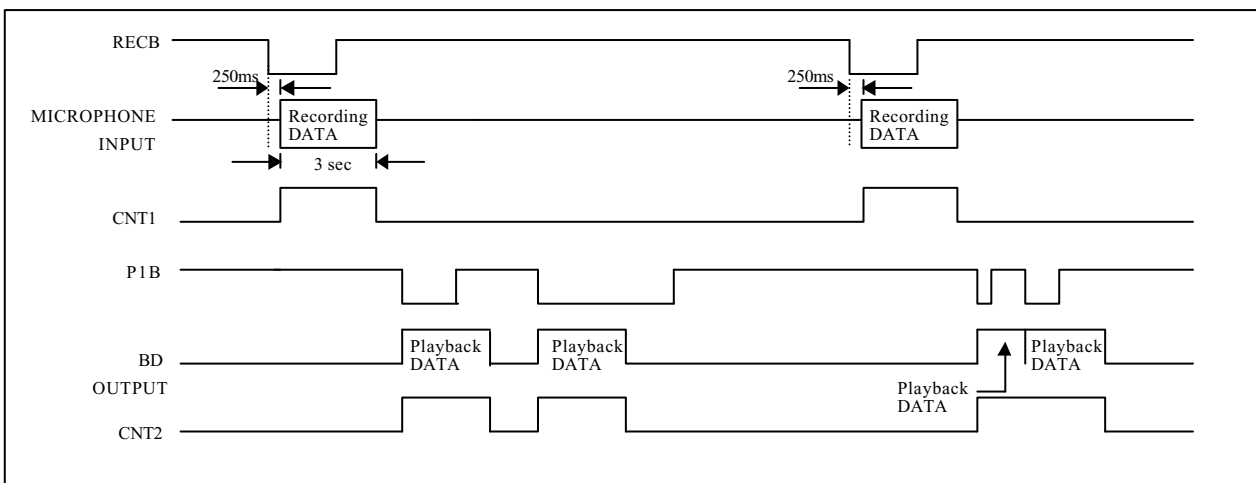

B. Pressing P1B or P2B during recording period will end the recording function, then playback the recording DATA instantly, but it will bypass empty memory DATA.

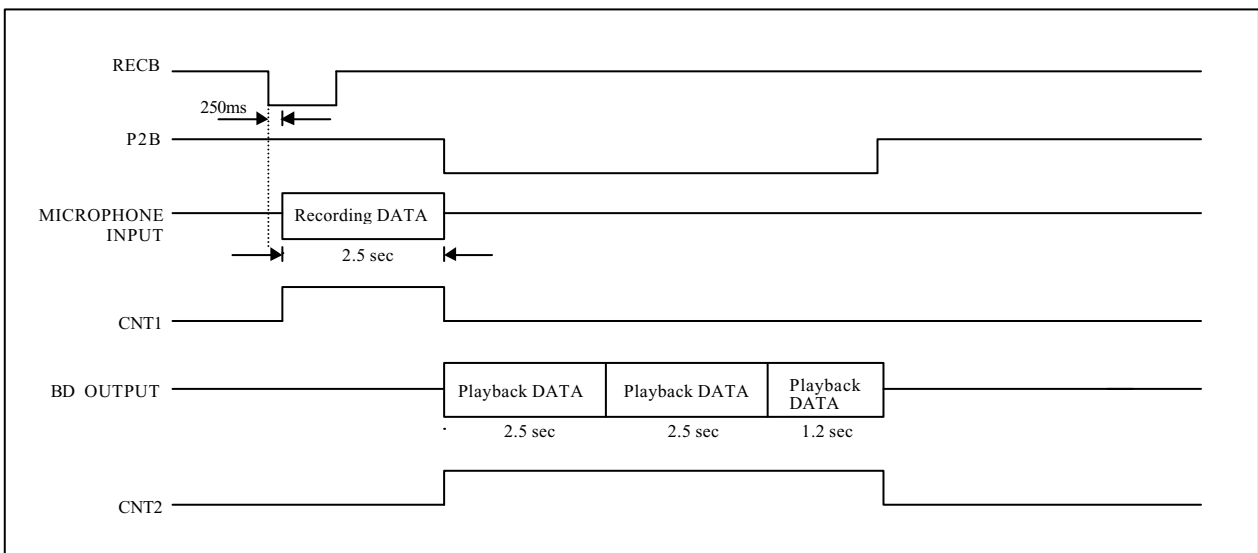
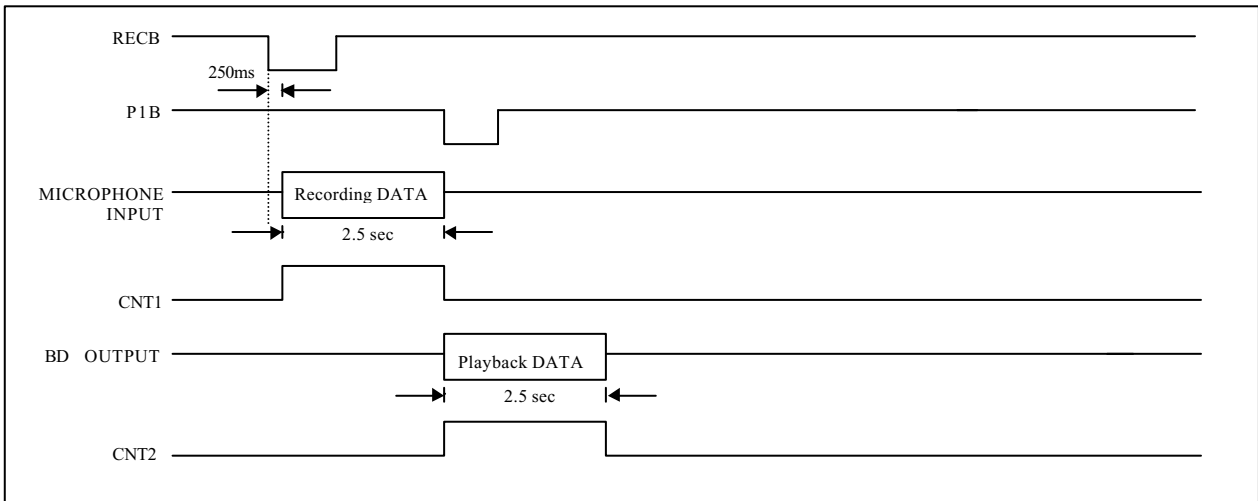

(2) Talk-Back mode (MODE=VDD)

- a. RTS0073 has a Power-ON enable function.
- b. RECB pin is a On/Off trigger in talk-back mode.
- c. If RTS0073 does not detect any voice, it will power OFF automatically after 15 seconds.

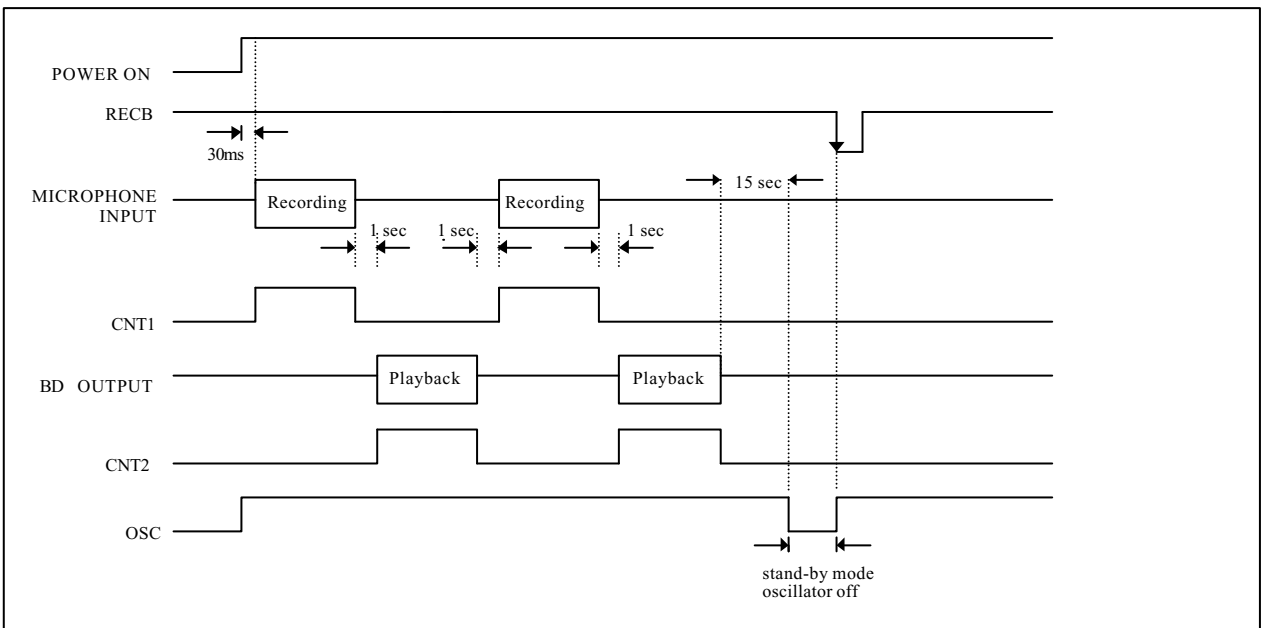
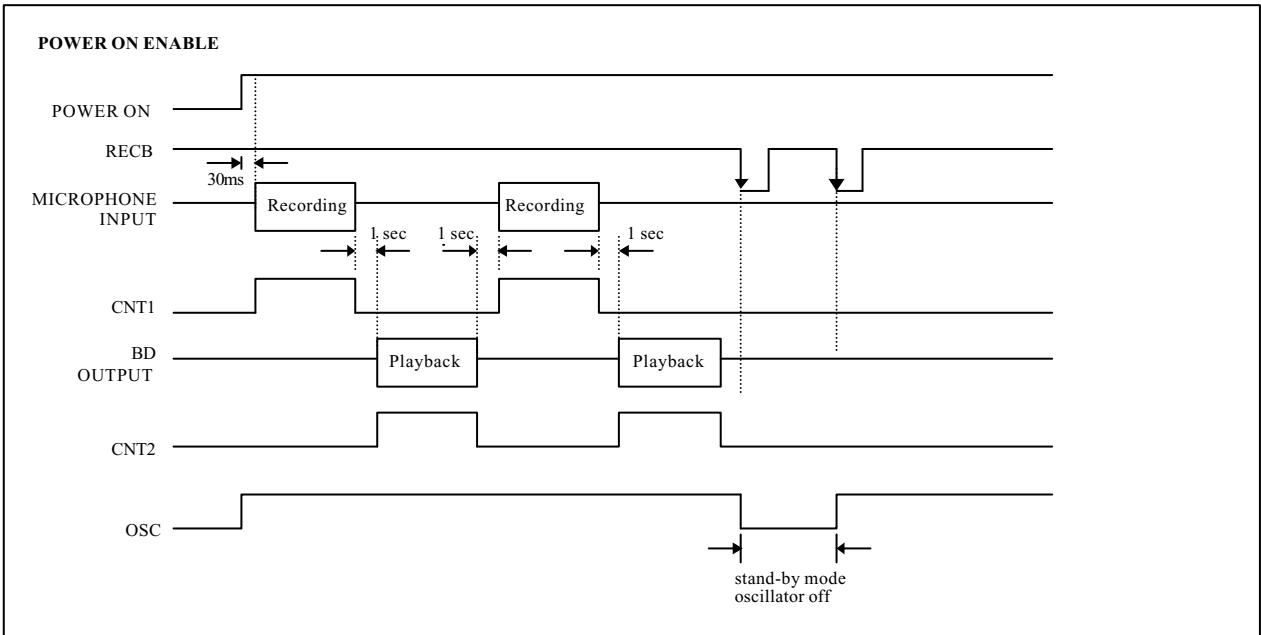

Application Circuit

(VDD = 4.5V)

1.

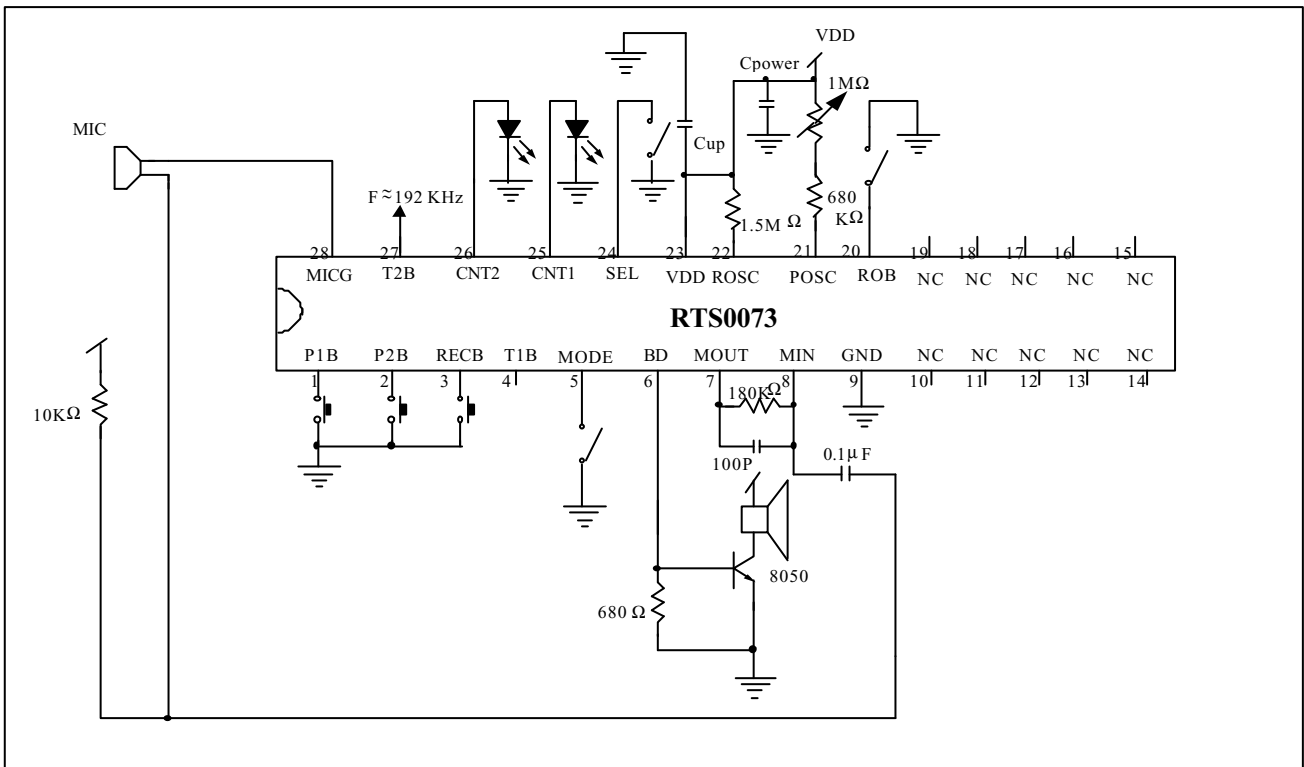

Note:

Cpower: POWER FILTER Cpower = 0.1μF ~ 10 μF

Cup: If connecting a capacitor near the VDD and GND pin, it can improve the operating voltage up to 6.4V. Cup = 0.1μF

2.

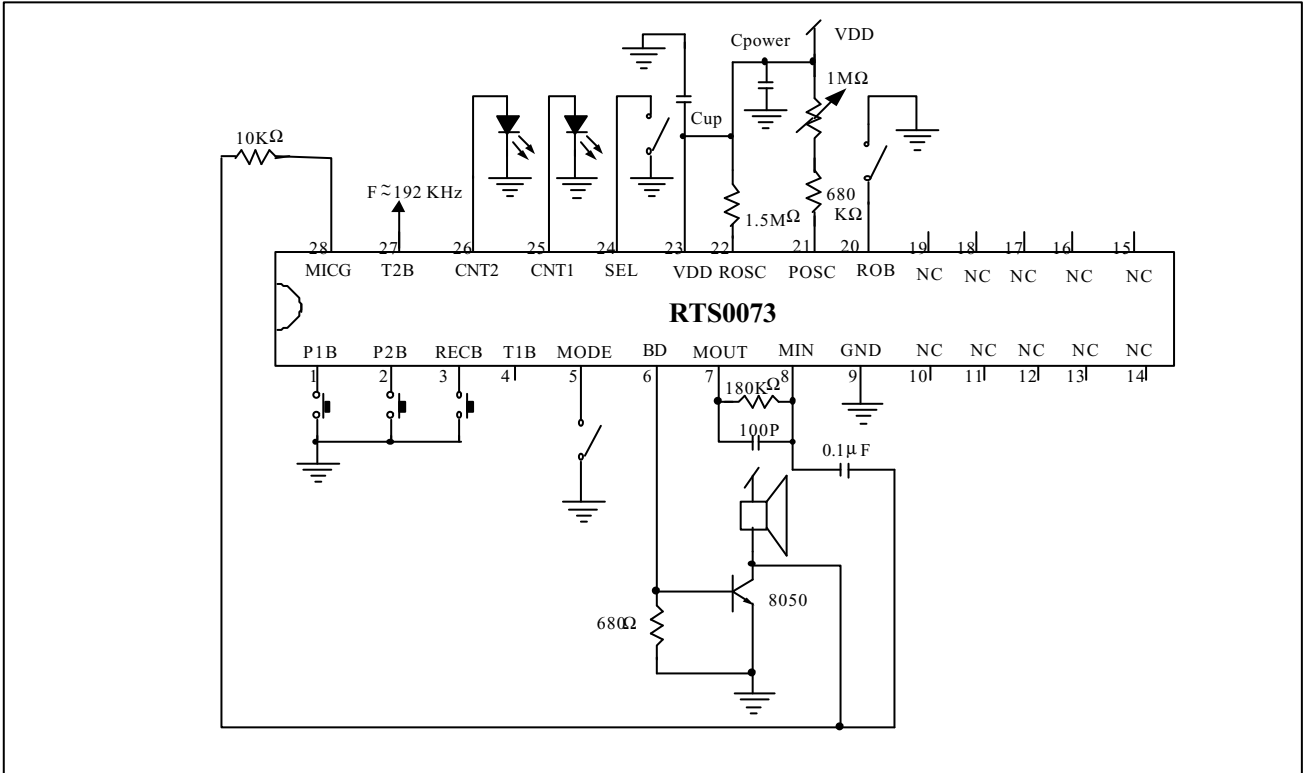

Note:

Cpower: POWER FILTER Cpower = 0.1μF ~ 10 μF

Cup: If connecting a capacitor near the VDD and GND pin, it can improve the operating voltage up to 6.4V. Cup = 0.1μF

Bonding Diagram

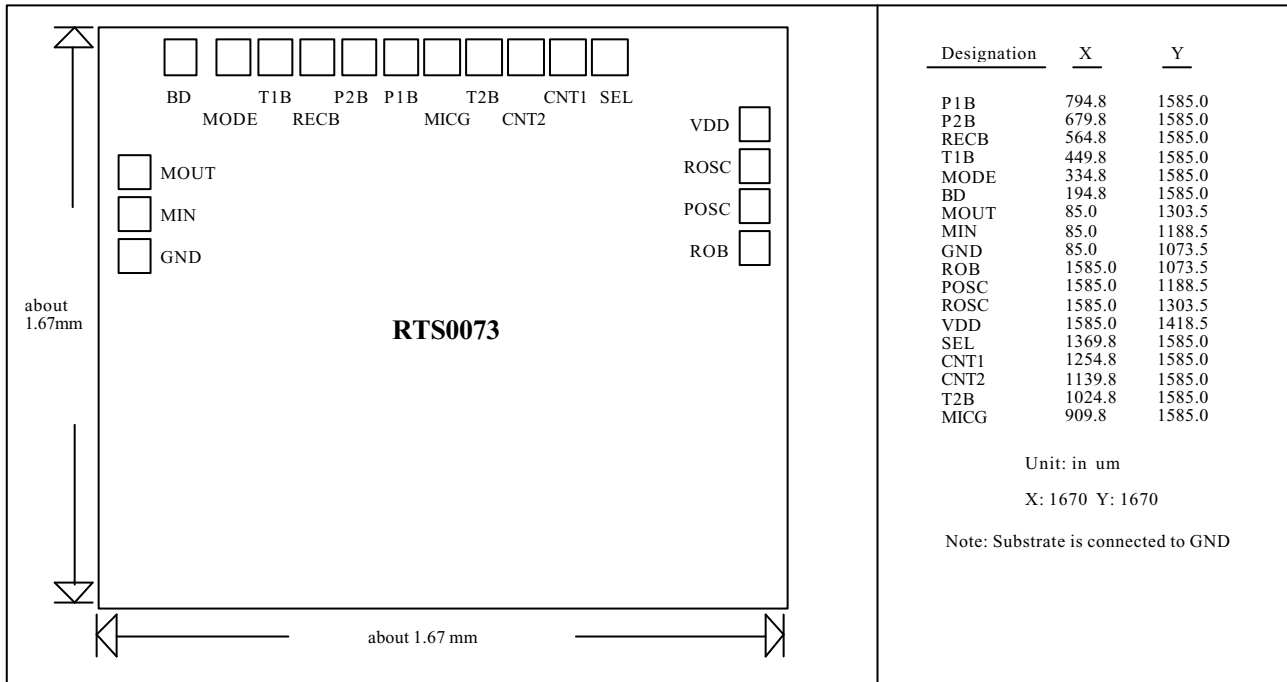

M-Square Technologies Corporation

A Subsidiary of Realtek Group

HEAD QUARTER

Floor 4, No. 2, Industry E. RD. IX, Science-Based
Industrial Park, Hsinchu, 300 Taiwan, R.O.C.
Tel: 886-3-6661028 Fax: 886-3-6661928

HONGKONG OFFICE

Room 1403, Charm Centre 700 Castle Peak
Rd., Lai Chi Kok Kowloon, Hong Kong
Tel: 852-29593235
Fax: 852-27425267

SHENZHEN OFFICE

Room 1508, Block A, Union Square, No.-
5022 Caitian Rd., Futian, Shenzhen
Tel: 6-755-2900672 Fax: 86-755-
2900681