



Continuous Rate 12.3Mb/s to 2.7Gb/s Clock and Data Recovery ICs

Preliminary Technical Data

ADN2817/ADN2818

FEATURES

- Serial data input: 12.3 Mb/s to 2.7 Gb/s
- Exceeds ITU-T Jitter Specifications
- Integrated Limiting Amp: 6mV sensitivity (ADN2817 only)
- Adjustable slice level: ± 100 mV (ADN2817 only)
- Patented dual-loop clock recovery architecture
- Programmable LOS detect (ADN2817 only)
- Slice level and sample phase adjustments (ADN2817 only)
- Integrated PRBS Generator and Detector
- No reference clock required
- Loss of lock indicator
- Supports Double Data Rate
- Relative Bit Error Rate Monitor
- Rate Selectivity without the use of a reference clock
- I²C™ interface to access optional features
- Single-supply operation: 3.3 V
- Low power: 650/600 mW (ADN2817/ADN2818)
- 5 mm \times 5 mm 32-lead LFCSP

APPLICATIONS

- SONET OC-1/3/12/48 and all associated FEC rates
- Fibre Channel, 2 \times Fibre Channel, GbE, HDTV, etc.
- WDM transponders
- Regenerators/repeaters
- Test equipment

FUNCTIONAL BLOCK DIAGRAM

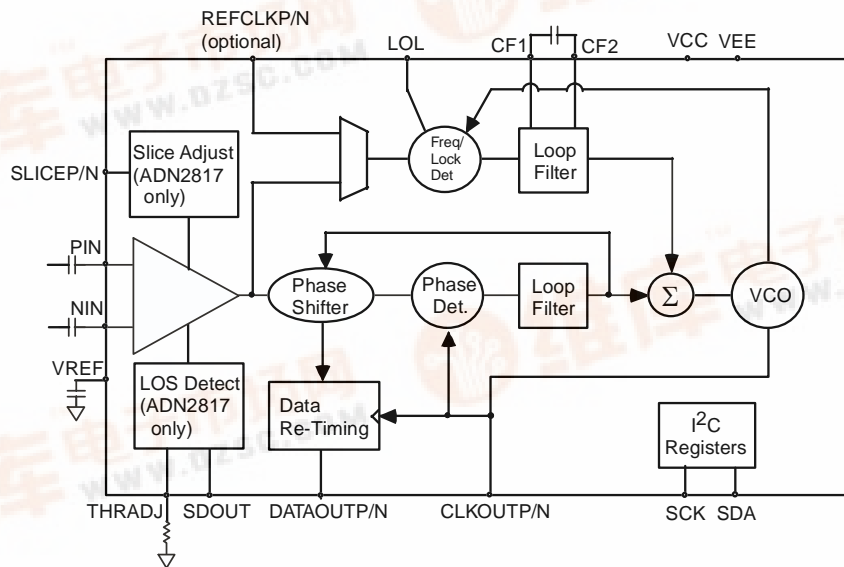

Figure 1 ADN2817/ADN2818 Functional Block Diagram

PRODUCT DESCRIPTION

The ADN2817/ADN2818 provides the receiver functions of quantization, signal level detect, and clock and data recovery for continuous data rates from 12.3 Mb/s to 2.7 Gb/s. The ADN2817/ADN2818 automatically locks to all data rates without the need for an external reference clock or programming. All SONET jitter requirements are exceeded, including jitter transfer, jitter generation, and jitter tolerance. All specifications are quoted for -40°C to $+85^{\circ}\text{C}$ ambient temperature, unless otherwise noted.

This device, together with a PIN diode and a TIA preamplifier, can implement a highly integrated, low cost, low power fiber optic receiver.

The ADN2817/ADN2818 have many optional features available via an I²C interface, e.g. the user can read back the data rate that the ADN2817/ADN2818 is locked on to, or the user can set the device to only lock to one particular data rate if provisioning of data rates is required.

The ADN2817/ADN2818 is available in a compact 5 mm \times 5 mm 32-lead chip scale package.



TABLE OF CONTENTS

Specifications.....	3	Functional Description	19
Jitter Specifications.....	4	Frequency Acquisition.....	19
Output and Timing Specifications	5	Limiting Amplifier	20
Absolute Maximum Ratings.....	6	Slice Adjust.....	20
Thermal Characteristics	7	Loss of Signal (LOS) Detector	20
ESD Caution.....	7	Lock Detector Operation	19
Timing Characteristics.....	8	Harmonic Detector	20
Pin Configuration and Function Descriptions.....	9	Squelch Mode	21
Typical Performance Characteristics	10	I2C Interface	21
I ² C Interface Timing and Internal Register Description.....	11	Reference Clock (Optional)	21
Terminology	15	Applications Information	27
Jitter Specifications	16	PCB Design Guidelines	27
Jitter Generation	16	DC-Coupled Application	29
Jitter Transfer.....	16	Coarse Data Rate Readback Look-Up Table.....	31
Jitter Tolerance	16	Outline Dimensions	33
Theory of Operation	17	Ordering Guide	33

REVISION HISTORY

Revision 0: Initial Version

Revision A: Remove Minimum Supply Current Spec

Revision B: Update spec table

SPECIFICATIONS

$T_A = T_{MIN}$ to T_{MAX} , $V_{CC} = V_{MIN}$ to V_{MAX} , $V_{EE} = 0$ V, $C_F = 0.47$ μ F, $SLICEP = SLICEN = V_{EE}$, Input Data Pattern: PRBS $2^{23} - 1$, unless otherwise noted.

Table 1.

Parameter	Conditions	Min	Typ	Max	Unit
QUANTIZER—DC CHARACTERISTICS					
Input Voltage Range	@ PIN or NIN, dc-coupled	1.8		2.8	V
Peak-to-Peak Differential Input	PIN – NIN			2.0	V
Input Common Mode Level	DC-coupled (see Figure 28, Figure 29, and Figure 30)	2.3	2.5	2.8	V
Differential Input Sensitivity	$2^{23} - 1$ PRBS, ac-coupled, ¹ BER = 1×10^{-10}	TBD	TBD		mV p-p
Input Overdrive	(see Figure 12)	TBD	TBD		mV p-p
Input Offset			TBD		μ V
Input RMS Noise	BER = 1×10^{-10}		TBD		μ V rms
QUANTIZER—AC CHARACTERISTICS					
Data Rate		12.3		2700	Mb/s
S11	@ 2.5 GHz		-15		dB
Input Resistance	Differential		100		Ω
Input Capacitance			0.65		pF
QUANTIZER—SLICE ADJUSTMENT					
Gain	SLICEP – SLICEN = ± 0.5 V	TBD	0.1	TBD	V/V
Differential Control Voltage Input	SLICEP – SLICEN			TBD	V
Control Voltage Range	DC level @ SLICEP or SLICEN	VEE		0.95	V
Slice Threshold Offset			1		mV
LOSS OF SIGNAL DETECT (LOS)					
Loss of Signal Detect Range (see Figure 5)	$R_{Thresh} = 0 \Omega$	TBD		TBD	mV
	$R_{Thresh} = 100$ k Ω	TBD		TBD	mV
Hysteresis (Electrical)	OC-48				
	$R_{Thresh} = 0 \Omega$	TBD		TBD	dB
	$R_{Thresh} = 100$ k Ω	TBD		TBD	dB
	OC-1				
	$R_{Thresh} = 0 \Omega$	TBD		TBD	dB
	$R_{Thresh} = 10$ k Ω	TBD		TBD	dB
LOS Assert Time	DC-coupled ²		TBD		ns
LOS De-Assert Time	DC-coupled ²		TBD		ns
LOSS OF LOCK DETECT (LOL)					
VCO Frequency Error for LOL Assert	With respect to nominal		1000		ppm
VCO Frequency Error for LOL De-Assert	With respect to nominal		250		ppm
LOL Response Time	12.3 Mb/s		4		ms
	OC-12		1.0		μ s
	OC-48		1.0		μ s
ACQUISITION TIME					
Lock to Data Mode	OC-48		1.3		ms
	OC-12		2.0		ms
	OC-3		3.4		ms
	OC-1		9.8		ms
	12.3 Mb/s		40.0		ms
Optional Lock to REFCLK Mode			10.0		ms

¹ PIN and NIN should be differentially driven and ac-coupled for optimum sensitivity.

² When ac-coupled, the LOS assert and de-assert time is dominated by the RC time constant of the ac coupling capacitor and the 50 Ω input termination of the ADN2817/ADN2818 input stage.

Parameter	Conditions	Min	Typ	Max	Unit
DATA RATE READBACK ACCURACY					
Coarse Readback	(See Table 14)		10		%
Fine Readback	In addition to REFCLK accuracy			200	ppm
	Data rate \leq 20 Mb/s			100	ppm
	Data rate $>$ 20 Mb/s				
POWER SUPPLY VOLTAGE		3.0	3.3	3.6	V
POWER SUPPLY CURRENT			200	TBD	mA
OPERATING TEMPERATURE RANGE		-40		+85	$^{\circ}$ C

JITTER SPECIFICATIONS

$T_A = T_{MIN}$ to T_{MAX} , $V_{CC} = V_{MIN}$ to V_{MAX} , $V_{EE} = 0$ V, $C_F = 0.47$ μ F, $SLICEP = SLICEN = V_{EE}$, Input Data Pattern: PRBS $2^{23} - 1$, unless otherwise noted.

Table 2.

Parameter	Conditions	Min	Typ	Max	Unit
PHASE-LOCKED LOOP CHARACTERISTICS					
Jitter Transfer BW	OC-48			TBD	kHz
	OC-12			TBD	kHz
	OC-3			TBD	kHz
Jitter Peaking	OC-48		0	TBD	dB
	OC-12		0	TBD	dB
	OC-3		0	TBD	dB
Jitter Generation	OC-48, 12 kHz to 20 MHz		0.001	TBD	UI rms
			0.02	TBD	UI p-p
	OC-12, 12 kHz to 5 MHz		0.001	TBD	UI rms
			0.01	TBD	UI p-p
	OC-3, 12 kHz to 1.3 MHz		0.001	TBD	UI rms
			0.01	TBD	UI p-p
Jitter Tolerance	OC-48, $2^{23} - 1$ PRBS				
	600 Hz	TBD			UI p-p
	6 kHz	TBD			UI p-p
	100 kHz	TBD			UI p-p
	1 MHz	TBD			UI p-p
	20 MHz	TBD			UI p-p
	OC-12, $2^{23} - 1$ PRBS				
	30 Hz ¹	TBD			UI p-p
	300 Hz ¹	TBD			UI p-p
	25 kHz	TBD			UI p-p
	250 kHz ¹	TBD			UI p-p
	OC-3, $2^{23} - 1$ PRBS				
	30 Hz ¹	TBD			UI p-p
	300 Hz ¹	TBD			UI p-p
	6500 Hz	TBD			UI p-p
	65 kHz	TBD			UI p-p
Power Supply Rejection	See Figure XX.		TBD		dB

¹ Jitter tolerance of the ADN2817/ADN2818 at these jitter frequencies is better than what the test equipment is able to measure.

OUTPUT AND TIMING SPECIFICATIONS

Table 3.

Parameter	Conditions	Min	Typ	Max	Unit
CML OUPUT CHARACTERISTICS (CLKOUTP/N, DATAOUTP/N)					
Single-Ended Output Swing	V_{SE} (see Figure 3)	300	350	600	mV
Differential Output Swing	V_{DIFF} (see Figure 3)	600	700	1200	mV
Output High Voltage	V_{OH}			VCC	V
Output Low Voltage	V_{OL}	VCC – 0.6	VCC – 0.35	VCC – 0.3	V
CML Ouputs Timing					
Rise Time	20% to 80%			TBD	ps
Fall Time	80% to 20%			TBD	ps
Setup Time	T_S (see Figure 2), OC-48	150	200	250	ps
Hold Time	T_H (see Figure 2), OC-48	150	200	250	ps
I²C INTERFACE DC CHARACTERISTICS					
Input High Voltage	V_{IH}	0.7 VCC			V
Input Low Voltage	V_{IL}			0.3 VCC	V
Input Current	$V_{IN} = 0.1 VCC$ or $V_{IN} = 0.9 VCC$	–10.0		+10.0	μA
Output Low Voltage	$V_{OL}, I_{OL} = 3.0 mA$			0.4	V
I²C INTERFACE TIMING (See Figure 11)					
SCK Clock Frequency				400	kHz
SCK Pulse Width High	t_{HIGH}	600			ns
SCK Pulse Width Low	t_{LOW}	1300			ns
Start Condition Hold Time	$t_{HD;STA}$	600			ns
Start Condition Setup Time	$t_{SU;STA}$	600			ns
Data Setup Time	$t_{SU;DAT}$	100			ns
Data Hold Time	$t_{HD;DAT}$	300			ns
SCK/SDA Rise/Fall Time	T_R/T_F	$20 + 0.1 C_b^1$		300	ns
Stop Condition Setup Time	$t_{SU;STO}$	600			ns
Bus Free Time between a Stop and a Start	t_{BUF}	1300			ns
REFCLK CHARACTERISTICS					
Input Voltage Range	Optional lock to REFCLK mode @ REFCLKP or REFCLKN				
	V_{IL}		0		V
	V_{IH}		VCC		V
Minimum Differential Input Drive			100		mV p-p
Reference Frequency		12.3		200	MHz
Required Accuracy			100		ppm
LVTTL DC INPUT CHARACTERISTICS					
Input High Voltage	V_{IH}	2.0			V
Input Low Voltage	V_{IL}			0.8	V
Input High Current	$I_{IH}, V_{IN} = 2.4 V$			5	μA
Input Low Current	$I_{IL}, V_{IN} = 0.4 V$	–5			μA
LVTTL DC OUTPUT CHARACTERISTICS					
Output High Voltage	$V_{OH}, I_{OH} = -2.0 mA$	2.4			V
Output Low Voltage	$V_{OL}, I_{OL} = 2.0 mA$			0.4	V

¹ C_b = total capacitance of one bus line in pF. If mixed with Hs-mode devices, faster fall-times are allowed (see Table 6).

BIT ERROR RATE MONITOR (BERMON) SPECIFICATIONS

$T_A = T_{MIN}$ to T_{MAX} , $V_{CC} = V_{MIN}$ to V_{MAX} , $V_{EE} = 0$ V, $C_F = 0.47$ μ F, $SLICEP = SLICEN = V_{EE}$, Input Data Pattern: PRBS $2^{23} - 1$, unless otherwise noted.

Table 4.

Parameter	Conditions	Min	Typ	Max	Unit
BERMON Primary Mode					
I2C Controlled Eye Profiling					
BER Accuracy	Input BER Range 1e-3 to 1e-12, Input DJ<0.4UI, DJ Ceiling>1e-2. Asymmetry <0.1UI. Requires external data processing algorithms to implement Q factor extrapolation.		+/-1		Decades
Numbits	Number of data bits to collect pseudo-errors. User programmable in increment factors of 2^3 over the range 2^{18} to 2^{39} .	2^{18}		2^{39}	UI
Measurement Time			Numbits/Datarate		s
Sample Phase Adjust Resolution			6		degrees
BER Range				5e-2	BER
Power Increase	BER On		177		mW
	BER Standby		88		mW
BERMON Secondary Mode					
Analog Voltage Output					
BER Accuracy	Input BER Range 1e-3 to 1e-9, Input DJ=0 UI, DJ Ceiling>1e-2. Asymmetry =0 UI. BER is read as a voltage on pin VBER, when Automode = 0.		+/-1		Decades
BER Accuracy	Input BER Range 1e-3 to 1e-9, Input DJ=0.2 UI, DJ Ceiling>1e-2. Asymmetry =0 UI. BER is read as a voltage on pin VBER, when Automode = 0.		+1/-2		Decades
Numbits	Number of data bits to collect pseudo-errors.		2^{27}		UI
Measurement Time	2.5Gb/s		0.054		s
	1Gb/s		0.134		s
	155Mb/s		0.865		s
	10Mb/s		1.34		s
Sample Phase Adjust Resolution			6		degrees
VBER	see Figure xx	0.1		0.9	V
Power Increase	BER Automode		177		mW

ABSOLUTE MAXIMUM RATINGS

$T_A = T_{MIN}$ to T_{MAX} , $V_{CC} = V_{MIN}$ to V_{MAX} , $V_{EE} = 0$ V, $C_F = 0.47$ μ F, SLICEP = SLICEN = VEE, unless otherwise noted.

Table 4.

Parameter	Rating
Supply Voltage (VCC)	4.2 V
Minimum Input Voltage (All Inputs)	VEE – 0.4 V
Maximum Input Voltage (All Inputs)	VCC + 0.4 V
Maximum Junction Temperature	125°C
Storage Temperature	–65°C to +150°C
Lead Temperature (Soldering 10 s)	300°C

Stress above those listed under Absolute Maximum Ratings may cause permanent damage to the device. This is a stress rating only and functional operation of the device at these or any other conditions above those indicated in the operational sections of this specification is not implied. Exposure to absolute maximum rating conditions for extended periods may affect device reliability.

THERMAL CHARACTERISTICS

Thermal Resistance

32-LFCSP, 4-layer board with exposed paddle soldered to VEE
 $\theta_{JA} = 28^\circ\text{C}/\text{W}$.

ESD CAUTION

ESD (electrostatic discharge) sensitive device. Electrostatic charges as high as 4000 V readily accumulate on the human body and test equipment and can discharge without detection. Although this product features proprietary ESD protection circuitry, permanent damage may occur on devices subjected to high energy electrostatic discharges. Therefore, proper ESD precautions are recommended to avoid performance degradation or loss of functionality.



TIMING CHARACTERISTICS

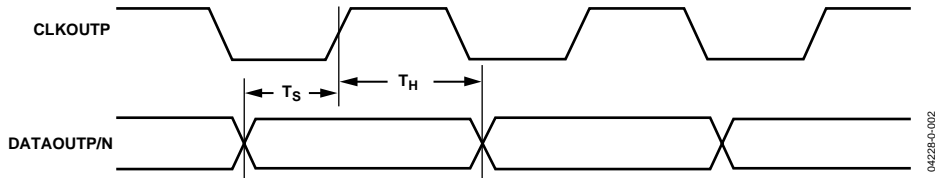

Figure 2. Output Timing

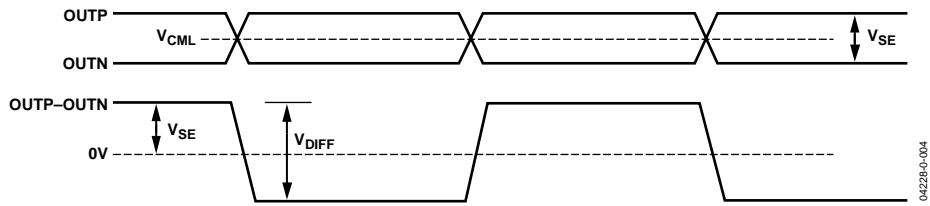

Figure 3. Single-Ended vs. Differential Output Specifications

PIN CONFIGURATION AND FUNCTION DESCRIPTIONS

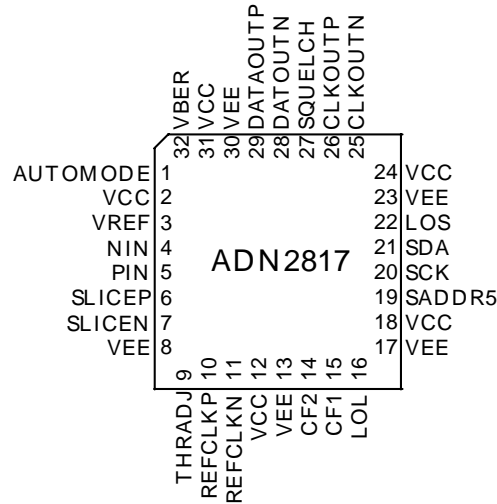

Figure 4. Pin Configuration

Table 5. Pin Function Descriptions

Pin No.	Mnemonic	Type ¹	Description
1	AUTOMODE	DI	Set to Logic Low to enable analog voltage output mode for BER monitor
2	VCC	P	Power for Limamp, LOS.
3	VREF	AO	Internal VREF Voltage. Decouple to GND with a 0.1 μ F capacitor.
4	NIN	AI	Differential Data Input. CML.
5	PIN	AI	Differential Data Input. CML.
6	SLICEP	AI	Differential Slice Level Adjust Input.
7	SLICEN	AI	Differential Slice Level Adjust Input.
8	VEE	P	GND for Limamp, LOS.
9	THRADJ	AI	LOS Threshold Setting Resistor.
10	REFCLKP	DI	Differential REFCLK Input. 12.3 MHz to 200 MHz.
11	REFCLKN	DI	Differential REFCLK Input. 12.3 MHz to 200 MHz.
12	VCC	P	VCO Power.
13	VEE	P	VCO GND.
14	CF2	AO	Frequency Loop Capacitor.
15	CF1	AO	Frequency Loop Capacitor.
16	LOL	DO	Loss of Lock Indicator. LVTTTL active high.
17	VEE	P	FLL Detector GND.
18	VCC	P	FLL Detector Power.
19	SADDR5	DI	Slave Address Bit 5.
20	SCK	DI	I ² C Clock Input.
21	SDA	DI	I ² C Data Input.
22	LOS	DO	Loss of Signal Detect Output. Active high. LVTTTL.
23	VEE	P	Output Buffer, I ² C GND.
24	VCC	P	Output Buffer, I ² C Power.
25	CLKOUTN	DO	Differential Recovered Clock Output. CML.
26	CLKOUTP	DO	Differential Recovered Clock Output. CML.
27	SQUELCH	DI	Disable Clock and Data Outputs. Active high. LVTTTL.
28	DATAOUTN	DO	Differential Recovered Data Output. CML.
29	DATAOUTP	DO	Differential Recovered Data Output. CML.
30	VEE	P	Phase Detector, Phase Shifter GND.
31	VCC	P	Phase Detector, Phase Shifter Power.
32	VBER	AO	Relative BER monitor output. Referred to GND, Analog Voltage Output.
Exposed Pad	Pad	P	Connect to GND

¹Type: P = power, AI = analog input, AO = analog output, DI = digital input, DO = digital output.

TYPICAL PERFORMANCE CHARACTERISTICS

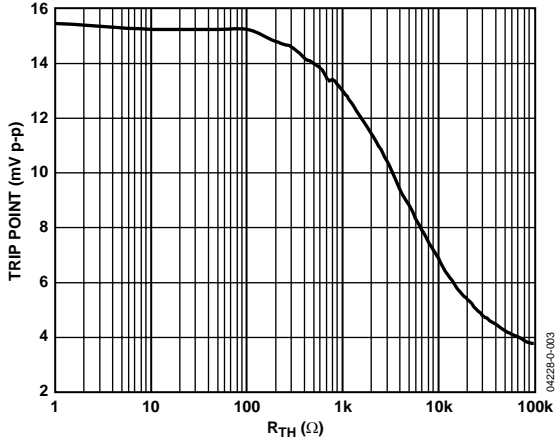

Figure 5. LOS Comparator Trip Point Programming

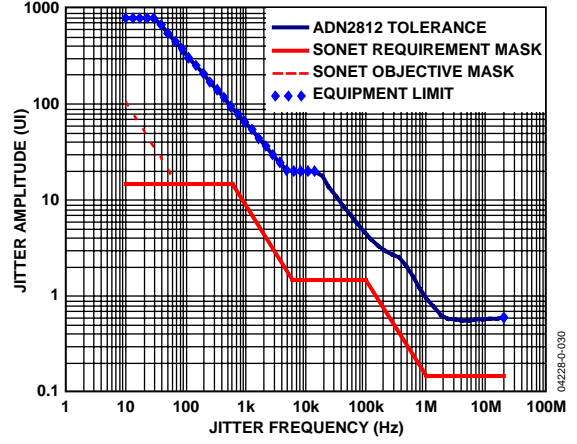

Figure 6. Typical Measured Jitter Tolerance OC-48

I²C INTERFACE TIMING AND INTERNAL REGISTER DESCRIPTION

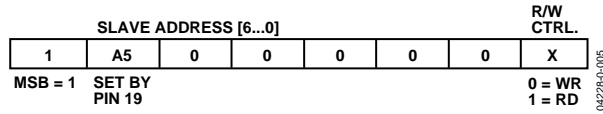

Figure 7. Slave Address Configuration



Figure 8. I²C Write Data Transfer

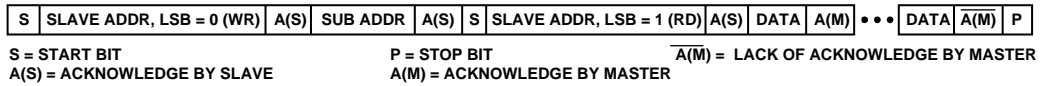

Figure 9. I²C Read Data Transfer

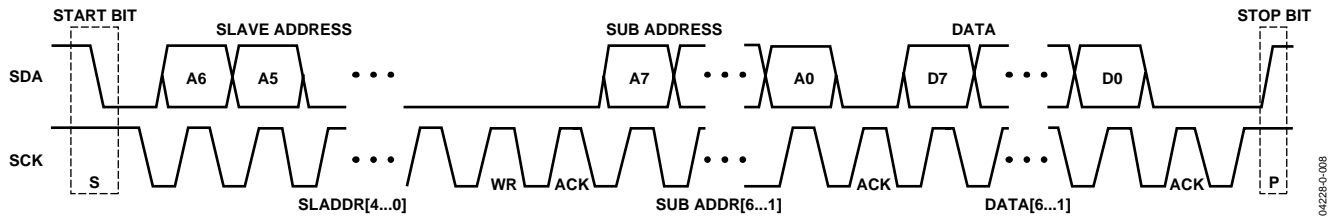

Figure 10. I²C Data Transfer Timing

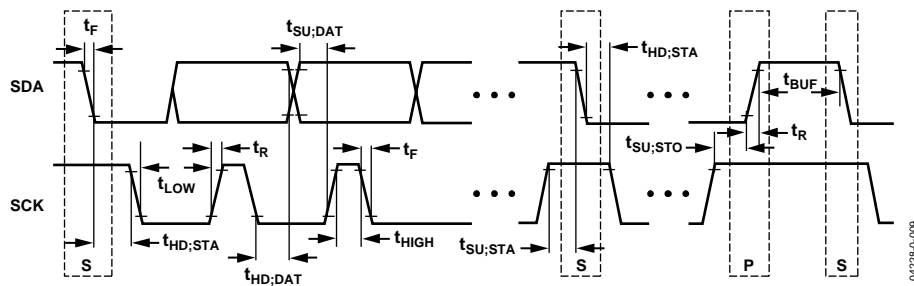

Figure 11. I²C Port Timing Diagram

Table 6. Internal Register Map¹

Reg Name	R/W	ADDRESS	D7	D6	D5	D4	D3	D2	D1	D0	
FREQ0	R	0x0	MSB							LSB	
FREQ1	R	0x1	MSB							LSB	
FREQ2	R	0x2	0	MSB						LSB	
RATE	R	0x3	COARSE_RD[8] MSB Coarse Data Rate Readback							COARSE_RD[1]	
MISC	R	0x4	x	x	LOS status	Static LOL	LOL status	datarate meas complete	x	COARSE_RD[0] LSB	
CTRLA	W	0x8	F _{REF} Range		Data Rate/DIV FREF Ratio				Measure Data Rate	Lock to Reference	
CTRLA_RD	R	0x5	readback CTRLA								
CTRLB	W	0x9	Config LOL	Reset MISC[4]	System Reset	0	Reset MISC[2]	0	0	0	
CTRLB_RD	R	0x6	readback CTRLB								
CTRLC	W	0x11	0	0	Set Signal Degrade Threshold	Enable Signal Degrade	LOS forces acquisition	Config LOS	Squelch Mode	Boost Output	
CTRLD	W	0x22	CDR Bypass	Disable DATA Buffer	Disable CLK Buffer		Initiate PRBS Sequence	PRBS Mode[2..0]			
FDDI_MODE	W	0x0D	FDDI Mode Enable	Subharmonic Ratio					0	0	
SEL_MODE	W	0x34	0	0	Acq Mode	Cont Rate / Single Rate	Datarate Range	CLK Holdover Mode 2A	CLK Holdover Mode 2B	0	
HI_CODE	W	0x35	HI_CODE[8]							HI_CODE[1]	
LO_CODE	W	0x36	LO_CODE[8]							LO_CODE[1]	
CODE_LSB	W	0x39	0	0	0	0	0	0	HI_CODE[0]	LO_CODE[0]	
BERCTLA	W	0x1E	BER Timer			Phase Polarity	BER Start Pulse	Error Count Byte Select, e.g. 011=Byte 3 of 5			
BERCTLB	W	0x1F	0	0	Enable BER	BER Stdby Mode	Clock XOR Input	BER Mode			
BERSTS	R	0x20	x	x	x	x	x	x	x	BER Meas Status	
BER_RES	R	0x21	BER_RES[7..0], BER Measurement Result								
BER_DAC	R	0x24	BER_DAC[7..0], Output of BER DAC								
PHASE	W	0x37	PHASE[7..0], 2's Complement Sample Phase Offset Adjustment								

¹All writable registers default to 0x00.

Table 7. Miscellaneous Register, MISC

		LOS Status	Static LOL	LOL Status	Datarate Measurement Complete	Coarse Rate Readback LSB	
D7	D6	D5	D4	D3	D2	D1	D0
x	x	0 = No loss of signal 1 = Loss of signal	0 = Waiting for next LOL 1 = Static LOL until reset	0 = Locked 1 = Acquiring	0 = Measuring datarate 1 = Measurement complete	x	COARSE_RD[0]

Table 8. Control Register, CTRLA¹

F _{REF} Range		Datarate/Div_F _{REF} Ratio				Measure Datarate	Lock to Reference	
D7	D6	D5	D4	D3	D2	D1	D0	
0	0	12.3 MHz to 25 MHz				0 0 0 0 1	Set to 1 to measure datarate	0 = Lock to input data 1 = Lock to reference clock
0	1	25 MHz to 50 MHz				0 0 0 1 2		
1	0	50 MHz to 100 MHz				0 0 1 0 4		
1	1	100 MHz to 200 MHz				n 2 ⁿ		
		1	0	0	0	256		

¹Where DIV_F_{REF} is the divided down reference referred to the 12.3 MHz to 25 MHz band (see the Reference Clock (Optional) section).

Table 9. Control Register, CTRLB

Config LOL	Reset MISC[4]	System Reset		Reset MISC[2]			
D7	D6	D5	D4	D3	D2	D1	D0
0 = LOL pin normal operation 1 = LOL pin is static LOL	Write a 1 followed by 0 to reset MISC[4]	Write a 1 followed by 0 to reset ADN2817/ADN2818	Set to 0	Write a 1 followed by 0 to reset MISC[2]	Set to 0	Set to 0	Set to 0

Table 10. Control Register, CTRLC

		Signal Degrade Threshold	Signal Degrade Mode		Config LOS	Squelch Mode	
D7	D6	D5	D4	D3	D2	D1	D0
Set to 0	Set to 0	0=Set SD Threshold to 9mV 1=Set SD Threshold to 1.9x LOS Threshold	0= Disable Signal Degrade Mode 1= Enable Signal Degrade Mode	Set to 0	0 = Active high LOS 1 = Active low LOS	0 = Squelch CLK and DATA 1 = Squelch CLK or DATA	Set to 0

Table 111. Control Register, CTRLD

CDR Bypass	Disable DATA Buffer	Disable CLK Buffer		Initiate PRBS	PRBS Mode			
D7	D6	D5	D4	D3	D2	D1	D0	
0=CDR Enabled 1=CDR Disabled	0=Data Buffer Enabled 1=Data Buffer Disabled	0=CLK Buffer Enabled 1=CLK Buffer Disabled	Set to 0	Write a 1 followed by 0 to initiate PRBS Generate Sequence	0 0 0 0 1	0 0 1 1 0	0 1 1 0	Power Down Generate Mode Detect Mode, compares errors Detect Mode, O/P to BER only Detect mode, BER not in use

Table 12. FDDI_MODE

FDDI Enable	Subharmonic Ratio [6..2]						
D7	D6	D5	D4	D3	D2	D1	D0
0= FDDI Mode Disabled 1= FDDI Mode Enabled	0 0 0 1	0 0 0 1	0 0 0 1	0 1 1 1	1 = 1 = 2 = 3 = 31	Set to 0	Set to 0

Table 13. SEL_MODE

		Mode Control 2	Mode Control 1	Mode Control 0	Clock Holdover Mode 2A	Clock Holdover Mode 2B	
D7	D6	D5	D4	D3	D2	D1	D0
Set to 0	Set to 0	0=LTD/LTR Mode 1=LTR Mode Only	0= Continuous Rate 1= Single Rate	0= Full Range (12.3M-2.7G) 1= Limited Range	Set to 1 for Clock Holdover Mode 2A	Set to 1 for Clock Holdover Mode 2B	Set to 0

Table 14. BERCTLA

Set BER Timer			Phase Polarity	BER Start Pulse	Error Count Byte Select		
D7	D6	D5	D4	D3	D2	D1	D0
0	0	0 = 2 ¹⁸ bits	0= Positive 1= Negative	Write a "1" followed by "0" to initiate BER measurement	0	0	0 = Byte 0
0	0	1 = 2 ²¹ bits			0	0	1 = Byte 1
0	1	0 = 2 ²⁴ bits			0	1	0 = Byte 2
0	1	1 = 2 ²⁷ bits			0	1	1 = Byte 3
1	0	0 = 2 ³⁰ bits			1	0	0 = Byte 4
1	0	1 = 2 ³³ bits			1	0	1 = Byte 5
1	1	0 = 2 ³⁶ bits					
1	1	1 = 2 ³⁹ bits					

Table 15. BERCTLB

		Enable BER	BER Standby Mode	Clock XOR Input	BER Mode		
D7	D6	D5	D4	D3	D2	D1	D0
Set to 0	Set to 0	0= BER Disabled 1= BER Enabled	0= BER meas enabled 1= BER meas in Stdby mode	Write a "1" followed by "0" to clock input to XOR	0	0	0 = NDC -> OB
					0	0	1 = DDC -> OB
					0	1	0 = DIV0 -> OB
					0	1	1 = DIV1 -> OB
					1	0	0 = CLK0,1 -> OB
					1	0	1 = NDC -> PRBS
					1	1	0 = DDC -> PRBS

TERMINOLOGY

Input Sensitivity and Input Overdrive

Sensitivity and overdrive specifications for the quantizer involve offset voltage, gain, and noise. The relationship between the logic output of the quantizer and the analog voltage input is shown in Figure 12. For sufficiently large positive input voltage, the output is always Logic 1 and, similarly for negative inputs, the output is always Logic 0. However, the transitions between output Logic Levels 1 and 0 are not at precisely defined input voltage levels, but occur over a range of input voltages. Within this range of input voltages, the output might be either 1 or 0, or it might even fail to attain a valid logic state. The width of this zone is determined by the input voltage noise of the quantizer. The center of the zone is the quantizer input offset voltage. Input overdrive is the magnitude of signal required to guarantee the correct logic level with 1×10^{-10} confidence level.

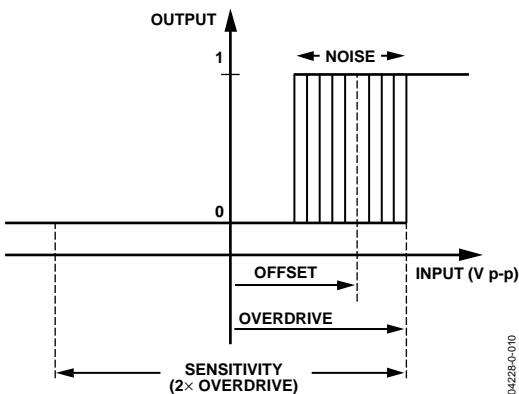

Figure 12. Input Sensitivity and Input Overdrive

Single-Ended vs. Differential

AC coupling is typically used to drive the inputs to the quantizer. The inputs are internally dc biased to a common-mode potential of ~ 2.5 V. Driving the ADN2817/ADN2818 single-ended and observing the quantizer input with an oscilloscope probe at the point indicated in Figure 13 shows a binary signal with an average value equal to the common-mode potential and instantaneous values both above and below the average value. It is convenient to measure the peak-to-peak amplitude of this signal and call the minimum required value the quantizer sensitivity. Referring to Figure 13, because both positive and negative offsets need to be accommodated, the sensitivity is twice the overdrive. The ADN2817/ADN2818 quantizer typically has 6 mV p-p sensitivity.

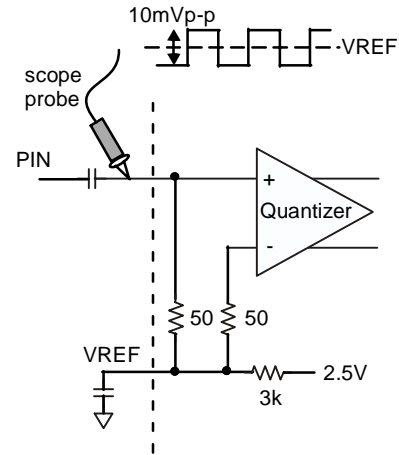

Figure 13. Single-Ended Sensitivity Measurement

Driving the ADN2817/ADN2818 differentially (see Figure 14), sensitivity seems to improve from observing the quantizer input with an oscilloscope probe. This is an illusion caused by the use of a single-ended probe. A 5 mV p-p signal appears to drive the ADN2817/ADN2818 quantizer. However, the single-ended probe measures only half the signal. The true quantizer input signal is twice this value, because the other quantizer input is a complementary signal to the signal being observed.

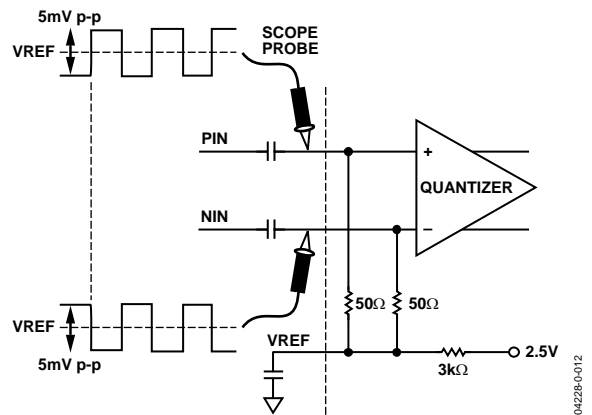

Figure 14. Differential Sensitivity Measurement

LOS Response Time

LOS response time is the delay between removal of the input signal and indication of loss of signal (LOS) at the LOS output, Pin 22. When the inputs are dc-coupled, the LOS assert time of the AD2817 is 500 ns typically and the de-assert time is 400 ns typically. In practice, the time constant produced by the ac coupling at the quantizer input and the 50 Ω on-chip input termination determines the LOS response time.

JITTER SPECIFICATIONS

The ADN2817/ADN2818 CDR is designed to achieve the best bit-error-rate (BER) performance and exceeds the jitter transfer, generation, and tolerance specifications proposed for SONET/SDH equipment defined in the Telcordia Technologies specification.

Jitter is the dynamic displacement of digital signal edges from their long-term average positions, measured in unit intervals (UI), where 1 UI = 1 bit period. Jitter on the input data can cause dynamic phase errors on the recovered clock sampling edge. Jitter on the recovered clock causes jitter on the retimed data.

The following sections briefly summarize the specifications of jitter generation, transfer, and tolerance in accordance with the Telcordia document (GR-253-CORE, Issue 3, September 2000) for the optical interface at the equipment level and the ADN2817/ADN2818 performance with respect to those specifications.

JITTER GENERATION

The jitter generation specification limits the amount of jitter that can be generated by the device with no jitter and wander applied at the input. For OC-48 devices, the band-pass filter has a 12 kHz high-pass cutoff frequency with a roll-off of 20 dB/decade, and a low-pass cutoff frequency of at least 20 MHz. The jitter generated must be less than 0.01 UI rms, and must be less than 0.1 UI p-p.

JITTER TRANSFER

The jitter transfer function is the ratio of the jitter on the output signal to the jitter applied on the input signal versus the frequency. This parameter measures the limited amount of the jitter on an input signal that can be transferred to the output signal (see Figure 15).

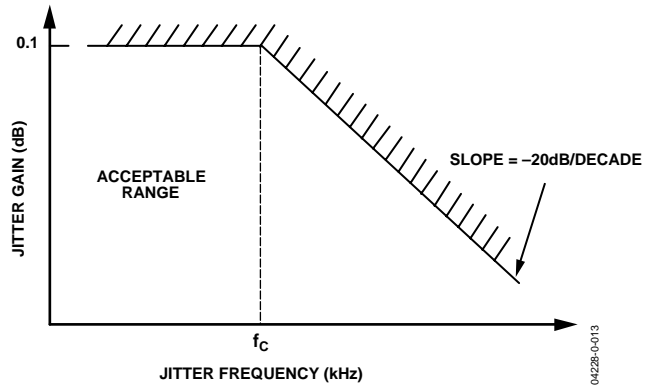

Figure 15. Jitter Transfer Curve

JITTER TOLERANCE

The jitter tolerance is defined as the peak-to-peak amplitude of the sinusoidal jitter applied on the input signal, which causes a 1 dB power penalty. This is a stress test intended to ensure that no additional penalty is incurred under the operating conditions (see Figure 16).

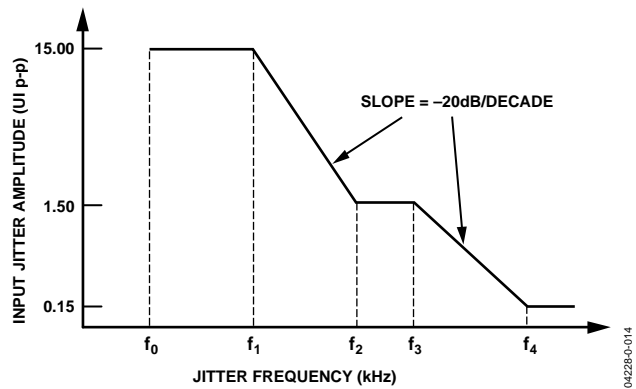

Figure 16. SONET Jitter Tolerance Mask

THEORY OF OPERATION

The ADN2817/ADN2818 is a delay- and phase-locked loop circuit for clock recovery and data retiming from an NRZ encoded data stream. The phase of the input data signal is tracked by two separate feedback loops, which share a common control voltage. A high speed delay-locked loop path uses a voltage controlled phase shifter to track the high frequency components of input jitter. A separate phase control loop, comprised of the VCO, tracks the low frequency components of input jitter. The initial frequency of the VCO is set by yet a third loop, which compares the VCO frequency with the input data frequency and sets the coarse tuning voltage. The jitter tracking phase-locked loop controls the VCO by the fine-tuning control.

The delay- and phase-loops together track the phase of the input data signal. For example, when the clock lags input data, the phase detector drives the VCO to higher frequency, and also increases the delay through the phase shifter; both these actions serve to reduce the phase error between the clock and data. The faster clock picks up phase, while the delayed data loses phase. Because the loop filter is an integrator, the static phase error is driven to zero.

Another view of the circuit is that the phase shifter implements the zero required for frequency compensation of a second-order phase-locked loop, and this zero is placed in the feedback path and, thus, does not appear in the closed-loop transfer function. Jitter peaking in a conventional second-order phase-locked loop is caused by the presence of this zero in the closed-loop transfer function. Because this circuit has no zero in the closed-loop transfer, jitter peaking is minimized.

The delay- and phase-loops together simultaneously provide wide-band jitter accommodation and narrow-band jitter filtering. The linearized block diagram in Figure 17 shows that the jitter transfer function, $Z(s)/X(s)$, is a second-order low-pass providing excellent filtering. Note that the jitter transfer has no zero, unlike an ordinary second-order phase-locked loop. This means that the main PLL loop has virtually zero jitter peaking (see Figure 18). This makes this circuit ideal for signal regenerator applications, where jitter peaking in a cascade of regenerators can contribute to hazardous jitter accumulation.

The error transfer, $e(s)/X(s)$, has the same high-pass form as an ordinary phase-locked loop. This transfer function is free to be optimized to give excellent wide-band jitter accommodation, because the jitter transfer function, $Z(s)/X(s)$, provides the narrow-band jitter filtering.

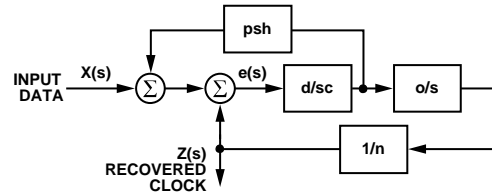

d = PHASE DETECTOR GAIN
o = VCO GAIN
c = LOOP INTEGRATOR
psh = PHASE SHIFTER GAIN
n = DIVIDE RATIO

JITTER TRANSFER FUNCTION

$$\frac{Z(s)}{X(s)} = \frac{1}{s^2 \frac{cn}{do} + s \frac{n \text{ psh}}{o} + 1}$$

TRACKING ERROR TRANSFER FUNCTION

$$\frac{e(s)}{X(s)} = \frac{s^2}{s^2 + s \frac{d \text{ psh}}{c} + \frac{do}{cn}}$$

04228-0-015

Figure 17. ADN2817/ADN2818 PLL/DLL Architecture

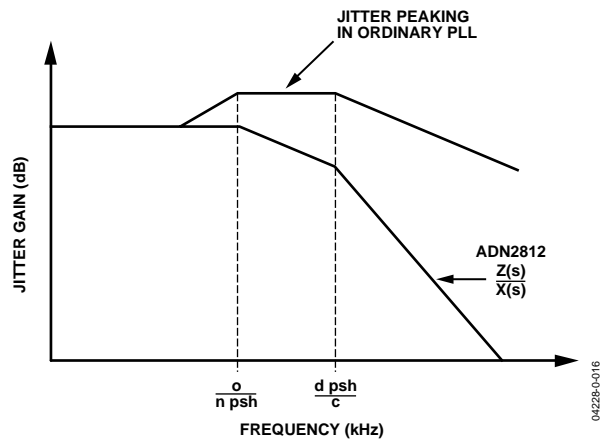

04228-0-016

Figure 18. ADN2817/ADN2818 Jitter Response vs. Conventional PLL

The delay- and phase-loops contribute to overall jitter accommodation. At low frequencies of input jitter on the data signal, the integrator in the loop filter provides high gain to track large jitter amplitudes with small phase error. In this case, the VCO is frequency modulated and jitter is tracked as in an ordinary phase-locked loop. The amount of low frequency jitter that can be tracked is a function of the VCO tuning range. A wider tuning range gives larger accommodation of low frequency jitter. The internal loop control voltage remains small for small phase errors, so the phase shifter remains close to the center of its range and thus contributes little to the low frequency jitter accommodation.

At medium jitter frequencies, the gain and tuning range of the VCO are not large enough to track input jitter. In this case, the VCO control voltage becomes large and saturates, and the VCO frequency dwells at one extreme of its tuning range or the other. The size of the VCO tuning range, therefore, has only a small effect on the jitter accommodation. The delay-locked loop control voltage is now larger, and so the phase shifter takes on the burden of tracking the input jitter. The phase shifter range, in UI, can be seen as a broad plateau on the jitter tolerance curve. The phase shifter has a minimum range of 2 UI at all data rates.

The gain of the loop integrator is small for high jitter frequencies, so that larger phase differences are needed to make the loop control voltage big enough to tune the range of the phase shifter. Large phase errors at high jitter frequencies

cannot be tolerated. In this region, the gain of the integrator determines the jitter accommodation. Because the gain of the loop integrator declines linearly with frequency, jitter accommodation is lower with higher jitter frequency. At the highest frequencies, the loop gain is very small, and little tuning of the phase shifter can be expected. In this case, jitter accommodation is determined by the eye opening of the input data, the static phase error, and the residual loop jitter generation. The jitter accommodation is roughly 0.5 UI in this region. The corner frequency between the declining slope and the flat region is the closed loop bandwidth of the delay-locked loop, which is roughly 3 MHz at OC-48.

FUNCTIONAL DESCRIPTION

FREQUENCY ACQUISITION

The ADN2817/ADN2818 acquires frequency from the data over a range of data frequencies from 12.3 Mb/s to 2.7 Gb/s. The lock detector circuit compares the frequency of the VCO and the frequency of the incoming data. When these frequencies differ by more than 1000 ppm, LOL is asserted. This initiates a frequency acquisition cycle. The VCO frequency is reset to the bottom of its range, which is 12.3 MHz. The frequency detector then compares this VCO frequency and the incoming data frequency and increments the VCO frequency, if necessary. Initially, the VCO frequency is incremented in large steps to aid fast acquisition. As the VCO frequency approaches the data frequency, the step size is reduced until the VCO frequency is within 250 ppm of the data frequency, at which point LOL is de-asserted.

Once LOL is de-asserted, the frequency-locked loop is turned off. The PLL/DLL pulls in the VCO frequency the rest of the way until the VCO frequency equals the data frequency.

The frequency loop requires a single external capacitor between CF1 and CF2, Pins 14 and 15. A $0.47 \mu\text{F} \pm 20\%$, X7R ceramic chip capacitor with $< 10 \text{ nA}$ leakage current is recommended. Leakage current of the capacitor can be calculated by dividing the maximum voltage across the $0.47 \mu\text{F}$ capacitor, $\sim 3 \text{ V}$, by the insulation resistance of the capacitor. The insulation resistance of the $0.47 \mu\text{F}$ capacitor should be greater than $300 \text{ M}\Omega$.

LOCK DETECTOR OPERATION

The lock detector on the ADN2817/ADN2818 has three modes of operation: normal mode, REFCLK mode, and static LOL mode.

Normal Mode

In normal mode, the ADN2817/ADN2818 is a continuous rate CDR that locks onto any data rate from 12.3 Mb/s to 2.7 Gb/s without the use of a reference clock as an acquisition aid. In this mode, the lock detector monitors the frequency difference between the VCO and the input data frequency, and de-asserts the loss of lock signal, which appears on LOL Pin 16, when the VCO is within 250 ppm of the data frequency. This enables the D/PLL, which pulls the VCO frequency in the remaining amount and also acquires phase lock. Once locked, if the input frequency error exceeds 1000 ppm (0.1%), the loss of lock signal is re-asserted and control returns to the frequency loop, which begins a new frequency acquisition starting at the lowest point in the VCO operating range, 12.3 MHz. The LOL pin remains asserted until the VCO locks onto a valid input data stream to within 250 ppm frequency error. This hysteresis is shown in Figure 19.

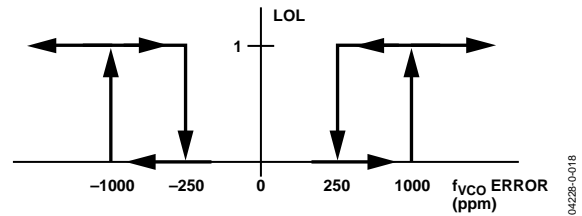

Figure 19. Transfer Function of LOL

LOL Detector Operation Using a Reference Clock

In this mode, a reference clock is used as an acquisition aid to lock the ADN2817/ADN2818 VCO. Lock to reference mode is enabled by setting CTRLA[0] to 1. The user also needs to write to the CTRLA[7:6] and CTRLA[5:2] bits in order to set the reference frequency range and the divide ratio of the data rate with respect to the reference frequency. For more details, see the Reference Clock (Optional) section. In this mode, the lock detector monitors the difference in frequency between the divided down VCO and the divided down reference clock. The loss of lock signal, which appears on the LOL Pin 16, is de-asserted when the VCO is within 250 ppm of the desired frequency. This enables the D/PLL, which pulls the VCO frequency in the remaining amount with respect to the input data and also acquires phase lock. Once locked, if the input frequency error exceeds 1000 ppm (0.1%), the loss of lock signal is re-asserted and control returns to the frequency loop, which re-acquires with respect to the reference clock. The LOL pin remains asserted until the VCO frequency is within 250 ppm of the desired frequency. This hysteresis is shown in Figure 19.

Static LOL Mode

The ADN2817/ADN2818 implements a static LOL feature, which indicates if a loss of lock condition has ever occurred and remains asserted, even if the ADN2817/ADN2818 regains lock, until the static LOL bit is manually reset. The I²C register bit, MISC[4], is the static LOL bit. If there is ever an occurrence of a loss of lock condition, this bit is internally asserted to logic high. The MISC[4] bit remains high even after the ADN2817/ADN2818 has re-acquired lock to a new data rate. This bit can be reset by writing a 1 followed by 0 to I²C Register Bit CTRLB[6]. Once reset, the MISC[4] bit remains de-asserted until another loss of lock condition occurs.

Writing a 1 to I²C Register Bit CTRLB[7] causes the LOL pin, Pin 16, to become a static LOL indicator. In this mode, the LOL pin mirrors the contents of the MISC[4] bit and has the functionality described in the previous paragraph. The CTRLB[7] bit defaults to 0. In this mode, the LOL pin operates in the normal operating mode, that is, it is asserted only when the ADN2817/ADN2818 is in acquisition mode and de-asserts when the ADN2817/ADN2818 has re-acquired lock.

HARMONIC DETECTOR

The ADN2817/ADN2818 provides a harmonic detector, which detects whether or not the input data has changed to a lower harmonic of the data rate that the VCO is currently locked onto. For example, if the input data *instantaneously* changes from OC-48, 2.488 Gb/s, to an OC-12, 622.080 Mb/s bit stream, this could be perceived as a valid OC-48 bit stream, because the OC-12 data pattern is exactly 4× slower than the OC-48 pattern. So, if the change in data rate is instantaneous, a 101 pattern at OC-12 would be perceived by the ADN2817/ADN2818 as a 111100001111 pattern at OC-48. If the change to a lower harmonic is instantaneous, a typical CDR could remain locked at the higher data rate.

The ADN2817/ADN2818 implements a harmonic detector that automatically identifies whether or not the input data has switched to a lower harmonic of the data rate that the VCO is currently locked onto. When a harmonic is identified, the LOL pin is asserted and a new frequency acquisition is initiated. The ADN2817/ADN2818 automatically locks onto the new data rate, and the LOL pin is de-asserted.

However, the harmonic detector does not detect higher harmonics of the data rate. If the input data rate switches to a higher harmonic of the data rate the VCO is currently locked onto, the VCO loses lock, the LOL pin is asserted, and a new frequency acquisition is initiated. The ADN2817/ADN2818 automatically locks onto the new data rate.

The time to detect lock to harmonic is

$$16,384 \times (T_d/\rho)$$

where:

$1/T_d$ is the new data rate. For example, if the data rate is switched from OC-48 to OC-12, then $T_d = 1/622$ MHz.

ρ is the data transition density. Most coding schemes seek to ensure that $\rho = 0.5$, for example, PRBS, 8B/10B.

When the ADN2817/ADN2818 is placed in lock to reference mode, the harmonic detector is disabled.

LIMITING AMPLIFIER (ADN2817 ONLY)

The limiting amplifier on the ADN2817 has differential inputs (PIN/NIN), which are internally terminated with 50 Ω to an on-chip voltage reference (VREF = 2.5 V typically). The inputs are typically ac-coupled externally, although dc coupling is possible as long as the input common mode voltage remains above 2.5 V (see Figure 28, Figure 29, and Figure 30 in the Applications Information section). Input offset is factory trimmed to achieve better than 6 mV typical sensitivity with minimal drift. The limiting amplifier can be driven differentially or single-ended.

SLICE AND SAMPLE PHASE ADJUST (ADN2817 ONLY)

The quantizer slicing level can be offset by ± 100 mV to mitigate the effect of amplified spontaneous emission (ASE) noise or duty cycle distortion by applying a differential voltage input of up to ± 0.95 V to SLICEP/N inputs. If no adjustment of the slice level is needed, SLICEP/N should be tied to VEE. The gain of the slice adjustment is ~ 0.1 V/V.

If the user is not using the BER monitoring function, sample phase adjustment can be utilized to optimize the horizontal sampling point of the incoming data eye. The ADN2817 automatically centers the sampling point to the best of its ability. However, sample phase adjustment could be used to compensate for any static phase offset of the CDR and duty cycle distortion of the incoming eye. Sample phase adjustment is applied to the incoming eye via the PHASE register. It is important to note that sample phase adjustment can not be used if the user is utilizing the BER monitoring capability. This is because the BER monitoring circuit requires control of the sample phase adjustment circuitry. Also, using the sample phase adjustment capability uses an additional 180mW of power.

LOSS OF SIGNAL (LOS) DETECTOR (ADN2817 ONLY)

The receiver front end LOS detector circuit detects when the input signal level has fallen below a user-adjustable threshold. The threshold is set with a single external resistor from Pin 9, THRADJ, to VEE. The LOS comparator trip point-versus-resistor value is illustrated in Figure 5. If the input level to the ADN2817/ADN2818 drops below the programmed LOS threshold, the output of the LOS detector, LOS Pin 22, is asserted to a Logic 1. The LOS detector's response time is ~ 500 ns by design, but is dominated by the RC time constant in ac-coupled applications. The LOS pin defaults to active high. However, by setting Bit CTRLC[2] to 1, the LOS pin is configured as active low.

There is typically 6 dB of electrical hysteresis designed into the LOS detector to prevent chatter on the LOS pin. This means that, if the input level drops below the programmed LOS threshold causing the LOS pin to assert, the LOS pin is not de-asserted until the input level has increased to 6 dB (2×) above the LOS threshold (see Figure 20).

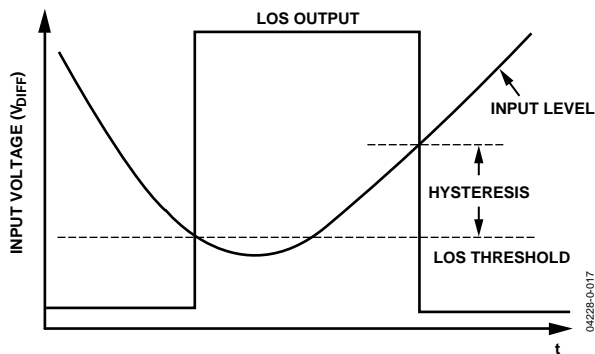

Figure 20. ADN2817 LOS Detector Hysteresis

The LOS detector and the SLICE level adjust can be used simultaneously on the ADN2817/ADN2818. This means that any offset added to the input signal by the SLICE adjust pins does not affect the LOS detector's measurement of the absolute input level.

SQUELCH MODE

Two squelch modes are available with the ADN2817/ADN2818. Squelch DATAOUT AND CLKOUT mode is selected when CTRLC[1] = 0 (default mode). In this mode, when the squelch input, Pin 27, is driven to a TTL high state, both the clock and data outputs are set to the zero state to suppress downstream processing. If the squelch function is not required, Pin 27 should be tied to VEE.

Squelch DATAOUT OR CLKOUT mode is selected when CTRLC[1] is 1. In this mode, when the squelch input is driven to a high state, the DATAOUT pins are squelched. When the squelch input is driven to a low state, the CLKOUT pins are squelched. This is especially useful in repeater applications, where the recovered clock may not be needed.

I²C INTERFACE

The ADN2817/ADN2818 supports a 2-wire, I²C compatible, serial bus driving multiple peripherals. Two inputs, serial data (SDA) and serial clock (SCK), carry information between any devices connected to the bus. Each slave device is recognized by a unique address. The ADN2817/ADN2818 has two possible 7-bit slave addresses for both read and write operations. The MSB of the 7-bit slave address is factory programmed to 1. B5 of the slave address is set by Pin 19, SADDR5. Slave address bits [4:0] are defaulted to all 0s. The slave address consists of the 7 MSBs of an 8-bit word. The LSB of the word sets either a read or write operation (see Figure 7). Logic 1 corresponds to a read operation, while Logic 0 corresponds to a write operation.

To control the device on the bus, the following protocol must be followed. First, the master initiates a data transfer by establishing a start condition, defined by a high to low transition on SDA while SCK remains high. This indicates that an address/data stream follows. All peripherals respond to the start condition and shift the next eight bits (the 7-bit address and the

R/W bit). The bits are transferred from MSB to LSB. The peripheral that recognizes the transmitted address responds by pulling the data line low during the ninth clock pulse. This is known as an acknowledge bit. All other devices withdraw from the bus at this point and maintain an idle condition. The idle condition is where the device monitors the SDA and SCK lines waiting for the start condition and correct transmitted address. The R/W bit determines the direction of the data. Logic 0 on the LSB of the first byte means that the master writes information to the peripheral. Logic 1 on the LSB of the first byte means that the master reads information from the peripheral.

The ADN2817/ADN2818 acts as a standard slave device on the bus. The data on the SDA pin is 8 bits long supporting the 7-bit addresses plus the R/W bit. The ADN2817/ADN2818 has 8 subaddresses to enable the user-accessible internal registers (see Table 1 through Table 7). It, therefore, interprets the first byte as the device address and the second byte as the starting subaddress. Autoincrement mode is supported, allowing data to be read from or written to the starting subaddress and each subsequent address without manually addressing the subsequent subaddress. A data transfer is always terminated by a stop condition. The user can also access any unique subaddress register on a one-by-one basis without updating all registers.

Stop and start conditions can be detected at any stage of the data transfer. If these conditions are asserted out of sequence with normal read and write operations, then they cause an immediate jump to the idle condition. During a given SCK high period, the user should issue one start condition, one stop condition, or a single stop condition followed by a single start condition. If an invalid subaddress is issued by the user, the ADN2817/ADN2818 does not issue an acknowledge and returns to the idle condition. If the user exceeds the highest subaddress while reading back in autoincrement mode, then the highest subaddress register contents continue to be output until the master device issues a no-acknowledge. This indicates the end of a read. In a no-acknowledge condition, the SDATA line is not pulled low on the ninth pulse. See Figure 8 and Figure 9 for sample read and write data transfers and Figure 10 for a more detailed timing diagram.

REFERENCE CLOCK (OPTIONAL)

A reference clock is not required to perform clock and data recovery with the ADN2817/ADN2818. However, support for an optional reference clock is provided. The reference clock can be driven differentially or single-ended. If the reference clock is not being used, then REFCLKP should be tied to VCC, and REFCLKN can be left floating or tied to VEE (the inputs are internally terminated to VCC/2). See Figure 21 through Figure 23 for sample configurations.

The REFCLK input buffer accepts any differential signal with a

peak-to-peak differential amplitude of greater than 100 mV (for example, LVPECL or LVDS) or a standard single-ended low voltage TTL input, providing maximum system flexibility. Phase noise and duty cycle of the reference clock are not critical and 100 ppm accuracy is sufficient.

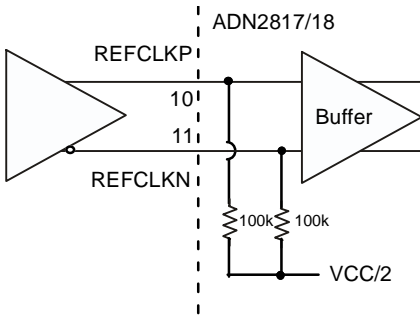

Figure 21. Differential REFCLK Configuration

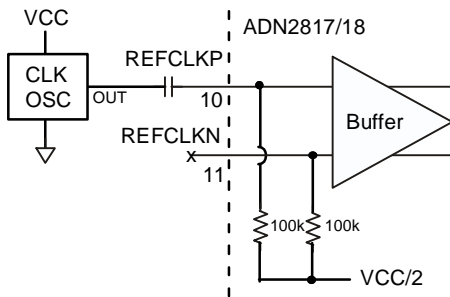

Figure 22. Single-Ended REFCLK Configuration

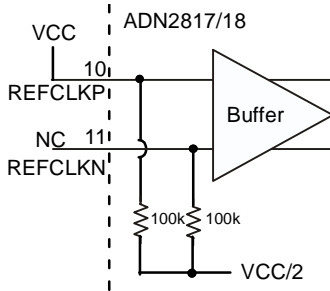

Figure 23. No REFCLK Configuration

The two uses of the reference clock are mutually exclusive. The reference clock can be used either as an acquisition aid for the ADN2817/ADN2818 to lock onto data, or to measure the frequency of the incoming data to within 0.01%. (There is the capability to measure the data rate to approximately $\pm 10\%$ without the use of a reference clock.) The modes are mutually exclusive, because, in the first use, the user knows exactly what the data rate is and wants to force the part to lock onto only that data rate; in the second use, the user does not know what the data rate is and wants to measure it.

Lock to reference mode is enabled by writing a 1 to I²C Register Bit CTRLA[0]. Fine data rate readback mode is enabled by writing a 1 to I²C Register Bit CTRLA[1]. Writing a 1 to both of these bits at the same time causes an indeterminate state and is

not supported.

Using the Reference Clock to Lock onto Data

In this mode, the ADN2817/ADN2818 locks onto a frequency derived from the reference clock according to the following equation:

$$\text{Data Rate}/2^{\text{CTRLA}[5:2]} = \text{REFCLK}/2^{\text{CTRLA}[7:6]}$$

The user must know exactly what the data rate is, and provide a reference clock that is a function of this rate. The ADN2817/ADN2818 can still be used as a continuous rate device in this configuration, provided that the user has the ability to provide a reference clock that has a variable frequency (see Application Note AN-632).

The reference clock can be anywhere between 12.3 MHz and 200 MHz. By default, the ADN2817/ADN2818 expects a reference clock of between 12.3 MHz and 25 MHz. If it is between 25 MHz and 50 MHz, 50 MHz and 100 MHz, or 100 MHz and 200 MHz, the user needs to configure the ADN2817/ADN2818 to use the correct reference frequency range by setting two bits of the CTRLA register, CTRLA[7:6].

Table 12. CTRLA Settings

CTRLA[7:6]	Range (MHz)	CTRLA[5:2]	Ratio
00	12.3 to 25	0000	1
01	25 to 50	0001	2
10	50 to 100	n	2 ⁿ
11	100 to 200	1000	256

The user can specify a fixed integer multiple of the reference clock to lock onto using CTRLA[5:2], where CTRLA should be set to the data rate/DIV_{FREF}, where DIV_{FREF} represents the divided-down reference referred to the 12.3 MHz to 25 MHz band. For example, if the reference clock frequency was 38.88 MHz and the input data rate was 622.08 Mb/s, then CTRLA[7:6] would be set to [01] to give a divided-down reference clock of 19.44 MHz. CTRLA[5:2] would be set to [0101], that is, 5, because

$$622.08 \text{ Mb/s}/19.44 \text{ MHz} = 2^5$$

In this mode, if the ADN2817/ADN2818 loses lock for any reason, it relocks onto the reference clock and continues to output a stable clock.

While the ADN2817/ADN2818 is operating in lock to reference mode, if the user ever changes the reference frequency, the F_{REF} range (CTRLA[7:6]), or the F_{REF} ratio (CTRLA[5:2]), this must be followed by writing a 0 to 1 transition into the CTRLA[0] bit to initiate a new lock to reference command.

Using the Reference Clock to Measure Data Frequency

The user can also provide a reference clock to measure the recovered data frequency. In this case, the user provides a reference clock, and the ADN2817/ADN2818 compares the frequency of the incoming data to the incoming reference clock

and returns a ratio of the two frequencies to 0.01% (100 ppm). The accuracy error of the reference clock is added to the accuracy of the ADN2817/ADN2818 data rate measurement. For example, if a 100-ppm accuracy reference clock is used, the total accuracy of the measurement is within 200 ppm.

The reference clock can range from 12.3 MHz and 200 MHz. The ADN2817/ADN2818 expects a reference clock between 12.3 MHz and 25 MHz by default. If it is between 25 MHz and 50 MHz, 50 MHz and 100 MHz, or 100 MHz and 200 MHz, the user needs to configure the ADN2817/ADN2818 to use the correct reference frequency range by setting two bits of the CTRLA register, CTRLA[7:6]. Using the reference clock to determine the frequency of the incoming data does not affect the manner in which the part locks onto data. In this mode, the reference clock is used only to determine the frequency of the data. For this reason, the user does not need to know the data rate to use the reference clock in this manner.

Prior to reading back the data rate using the reference clock, the CTRLA[7:6] bits must be set to the appropriate frequency range with respect to the reference clock being used. A fine data rate readback is then executed as follows:

Step 1: Write a 1 to CTRLA[1]. This enables the fine data rate measurement capability of the ADN2817/ADN2818. This bit is level sensitive and does not need to be reset to perform subsequent frequency measurements.

Step 2: Reset MISC[2] by writing a 1 followed by a 0 to CTRLB[3]. This initiates a new data rate measurement.

Step 3: Read back MISC[2]. If it is 0, then the measurement is not complete. If it is 1, then the measurement is complete and the data rate can be read back on FREQ[22:0]. The time for a data rate measurement is typically 80 ms.

Step 4: Read back the data rate from registers FREQ2[6:0], FREQ1[7:0], and FREQ0[7:0].

Use the following equation to determine the data rate:

$$f_{\text{DATARATE}} = (\text{FREQ}[22..0] \times f_{\text{REFCLK}}) / 2^{(14 + \text{SEL_RATE})}$$

where:

FREQ[22:0] is the reading from FREQ2[6:0] (MSByte), FREQ1[7:0], and FREQ0[7:0] (LSByte).

Table 13.

D22	D21...D17	D16	D15	D14...D9	D8	D7	D6...D1	D0
FREQ2[6:0]			FREQ1[7:0]			FREQ0[7:0]		

f_{DATARATE} is the data rate (Mb/s).

f_{REFCLK} is the REFCLK frequency (MHz).

SEL_RATE is the setting from CTRLA[7:6].

For example, if the reference clock frequency is 32 MHz, $\text{SEL_RATE} = 1$, since the CTRLA[7:6] setting would be [01], because the reference frequency would fall into the 25 MHz to 50 MHz range. Assume for this example that the input data rate is 2.488 Gb/s (OC-48). After following Steps 1 through 4, the value that is read back on FREQ[22:0] = 0x26E010, which is equal to 2.5477×10^6 . Plugging this value into the equation yields

$$(2.5477 \times 10^6) / (2^{(14+1)}) = 2.488 \text{ Gb/s}$$

If subsequent frequency measurements are required, CTRLA[1] should remain set to 1. It does not need to be reset. The measurement process is reset by writing a 1 followed by a 0 to CTRLB[3]. This initiates a new data rate measurement. Follow Steps 2 through 4 to read back the new data rate.

Note: A data rate readback is valid only if LOL is low. If LOL is high, the data rate readback is invalid.

Additional Features Available via the I²C Interface Coarse Data Rate Readback

The data rate can be read back over the I²C interface to approximately $\pm 10\%$ without the need of an external reference clock. A 9-bit register, COARSE_RD[8:0], can be read back when LOL is de-asserted. The 8 MSBs of this register are the contents of the RATE[7:0] register. The LSB of the COARSE_RD register is Bit MISC[0].

Table 14 provides coarse data rate readback to within $\pm 10\%$.

Relative Bit Error Rate Monitor

The ADN2817 has a Bit Error Rate (BER) measurement feature that provides for an estimation of the actual bit error rate of the IC. The feature also allows data eye jitter profiling and Q-factor estimation.

The implementation relies on the fact that by knowing the BER at sampling phases offset from the ideal sampling phase, it is possible to extrapolate to obtain an estimate of the BER at the actual sampling instant. This extrapolation relies on the assumption that the input jitter is composed of deterministic and random (gaussian) components. The implementation requires off-chip control and data processing to estimate the actual BER.

Brief Overview of Modes of Operation

Two modes of operation are available for the BER feature. Only one mode can be operational at a time. The primary mode is to scan the input eye in the range of ± 0.5 UI of the data centre, and read the measured pseudo-BER over the I2C. The user will then use the previously discussed algorithms to determine the BER. Using the BER feature in this way provides for the greatest accuracy in BER estimation as the magnitude of both Random (Gaussian) Jitter and Deterministic Jitter can be estimated, and used to predict the actual BER. In the secondary mode the part autonomously samples the PBER at 0.1UI offset, decodes this value to provide an estimate of the input BER. This estimate is output via a DAC as an analogue voltage output.

Primary Mode

Power Saving

There are three power modes in primary mode.

In "BER Off" mode all the BER circuitry will be powered down, and operation of the DLL will be the same as the ADN2812.

In "BER On" mode all of the BER logic and all the clock phase interpolators will be powered up. The user can perform a PBER measurement through the I2C. The clock signal from the VCO passes through the clock phase interpolator, to the NDC and DDC.

In "BER Standby" mode the BER logic and the DDC clock phase interpolators are powered down. The dummy clock phase interpolator is powered up. The clock signal from the VCO passes through the clock phase interpolator to the NDC only. These modes are defined to allow optimal power saving opportunities. It is not possible to switch between BER Off

mode and BER On mode without losing lock. This is because we must route the NDC clock signal through different circuitry in going from one mode to the other. Switching between BER Standby mode and BER On mode is achieved without interrupting the data recovery. The incremental power between BER Off and BER Standby mode is 88mW, and that between BER Off and BER On modes is 177mW.

BER On Mode

The BER On mode of operation allows the user to scan the incoming data eye in the time dimension and build up a profile of the BER statistics.

User Protocol

User Powers Up BER Circuitry, through I2C.

User initiates BER measurement. Sample Phase Offset & Number of data bits to be counted (Numbits - choice between 2^{18} , 2^{21} , 2^{24} , 2^{27} , 2^{30} , 2^{33} , 2^{36} or 2^{39}) are supplied by user, through I2C.

Apply Reset Pulse to BER through I2C.

BER Logic indicates End Of BER Measurement with EOBM signal and updates the number of counted errors on NumErrors<39:0>

User must poll the I2C to determine if EOBM has been asserted.

User reads back NumErrors<39:0>, through the I2C. BER for programmed sample phase is calculated as Numerrors/Numbits.

User Powers Down BER, or requests another BER measurement (step 2).

The user will sweep the phase over 0 to 1 UI, to get the BER profile required.

Note: The ADN2817 does not output the BER at the normal decision instant. It outputs pseudo-BER measurements to the left and right of the normal decision instants, from which the user must calculate what the BER is at the normal decision instant. A microprocessor will be required to parse the data, detecting and removing non-gaussian regions and using the remaining data for BER extrapolation.

Secondary Mode of Operation

A secondary mode of operation is implemented. This mode is to give easy access to a coarse estimate of the eye quality. The circuitry is similar to that already described except that the measurement is performed autonomously by the ADN2817, and the result is output as a voltage on a pin, from which the actual BER can be inferred. As this mode does not perform scanning of the eye to separate out deterministic from random jitter effects the method can only predict the BER to within perhaps 2 decades, under normal applied jitter conditions. The user merely has to bring the Automode pin low, and read the voltage on the VBER pin, see Figure XX. Alternatively a 6 bit value can be read over the I2C. In secondary mode the dynamic range is limited.

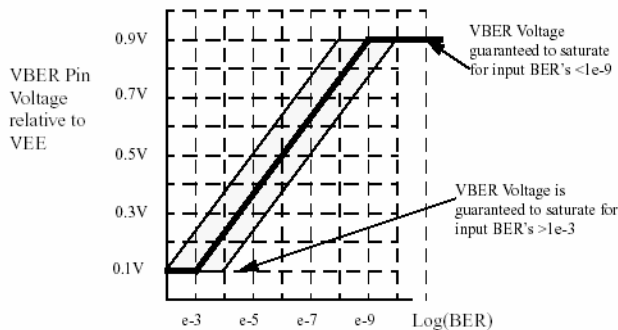

Figure XX. VBER -vs- Bit Error Rate

LOS Configuration

The LOS detector output, LOS Pin 22, can be configured to be either active high or active low. If CTRLC[2] is set to Logic 0 (default), the LOS pin is active high when a loss of signal condition is detected. Writing a 1 to CTRLC[2] configures the LOS pin to be active low when a loss of signal condition is detected.

System Reset

A frequency acquisition can be initiated by writing a 1 followed by a 0 to the I²C Register Bit CTRLB[5]. This initiates a new frequency acquisition while keeping the ADN2817/ADN2818 in the operating mode that it was previously programmed to in registers CTRL[A], CTRL[B], and CTRL[C].

FDDI Mode

A scheme has been implemented on the ADN2817/2818 that enables the device to lock to input data streams that appear as sub-harmonics of the desired datarate, e.g. FDDI during link synchronization. This works for any code where a subharmonic down to the 31st is transmitted. FDDI uses the 5th subharmonic. The implementation requires certain programming by the user and more importantly certain assumptions about the incoming data.

The user is required to program the part into FDDI mode by setting bit FDDI_MODE[7]=1. The user then needs to program the target datarate, (for FDDI this is 125MHz). This is done by programming an upper and lower 9-bit code into I2C registers HI_CODE[8..0], LO_CODE[8..0], and CODE_LSB[1..0]. See Table XX for a look-up table showing the correct register settings for each datarate. The user must also program the subharmonic ratio into I2C register FDDI_MODE[6..2] that the ADN2817/18 needs to lock on to, e.g. FDDI_MODE[6..2] = 00101 for FDDI (5th subharmonic). The user has to de-program FDDI mode before the next datarate is applied.

Here is what is required of the incoming data:

1. The subharmonic must be a clock-type waveform i.e. transition density equal to 1 at the subharmonic frequency.
2. The subharmonic must be continued to be applied until LOL goes LOW, i.e. until acquisition is completed. It doesn't matter how long the subharmonic remains after LOL goes LOW.

In FDDI Mode, the output of the ADN2817 is squelched until the device has acquired lock of the subharmonic input. This causes all zeros to be transmitted out of the 2817 until lock has been achieved. Once locked, the outputs are enabled and begin transmitting data. For FDDI protocol, this would be when the 'H' symbols are being transmitted during link synchronization.

Double Data Rate Mode

Setting I2C bit XXXX[X] = 1 puts the ADN2817/18 clock output through divide by two circuitry allowing direct interfacing to FPGAs that support data clocking on both rising and falling edges.

CLK HOLDOVER MODE

CLK Holdover Mode 2A:

This mode of operation will be available in all LTD modes: The output clock frequency will remain within +/-5% if the input data is removed or changed. To operate in this mode, the user would write to the I2C to put the part into CLK Holdover Mode 2A mode by setting SEL_MODE[2]=1. The user must then initiate an acquisition via a software reset. The device will then lock onto the input datarate. At this point the output frequency remains within +/- 5% of the initial acquired value regardless of whether or not the input data is taken away or the datarate changes. Only a sw reset can initiate a new acquisition in this mode.

CLK Holdover Mode 2B:

This mode is selected by setting SEL_MODE[1]=1. In this mode, the output clock stays within +/-5% of the initial acquired frequency, even if the input data is taken away. Unlike CLK Holdover Mode 2A, in this mode the ADN2817/18 will initiate a new frequency acquisition automatically if the input datarate changes. This mode requires the inputs to be DC coupled because if the inputs are AC coupled and the input is taken away, any noise present on the inputs may be large enough to trigger a new frequency acquisition which would cause the clock output frequency to change.

CDR BYPASS MODE

The CDR on the ADN2817/18 can be bypassed by setting bit CTRLD[7]=1. In this mode the ADN2817/18 will feed the input directly through the input amplifiers to the output buffer,

completely bypassing the CDR.

DISABLE OUTPUT BUFFERS

The ADN2817/18 provides the option of disabling the output

buffers for power savings. The clock output buffers can be disabled by setting CTRLD[5]=1. For additional power savings, e.g. in a low power standby mode, the data output buffers can also be disabled by setting CTRLD[6]=1.

APPLICATIONS INFORMATION

PCB DESIGN GUIDELINES

Proper RF PCB design techniques must be used for optimal performance.

Power Supply Connections and Ground Planes

Use of one low impedance ground plane is recommended. The VEE pins should be soldered directly to the ground plane to reduce series inductance. If the ground plane is an internal plane and connections to the ground plane are made through vias, multiple vias can be used in parallel to reduce the series inductance, especially on Pin 23, which is the ground return for the output buffers. The exposed pad should be connected to the GND plane using plugged vias so that solder does not leak through the vias during reflow.

Use of a 10 μF electrolytic capacitor between VCC and VEE is recommended at the location where the 3.3 V supply enters the PCB. When using 0.1 μF and 1 nF ceramic chip capacitors, they should be placed between the IC power supply VCC and VEE, as close as possible to the ADN2817/ADN2818 VCC pins.

If connections to the supply and ground are made through vias, the use of multiple vias in parallel helps to reduce series inductance, especially on Pin 24, which supplies power to the high speed CLKOUTP/CLKOUTN and DATAOUTP/DATAOUTN output buffers. Refer to the schematic in Figure 24 for recommended connections.

By using adjacent power supply and GND planes, excellent high frequency decoupling can be realized by using close spacing between the planes. This capacitance is given by

$$C_{plane} = 0.88\epsilon_r A/d \text{ (pF)}$$

where:

ϵ_r is the dielectric constant of the PCB material.

A is the area of the overlap of power and GND planes (cm^2).

d is the separation between planes (mm).

For FR-4, $\epsilon_r = 4.4$ mm and 0.25 mm spacing, $C \sim 15 \text{ pF/cm}^2$.

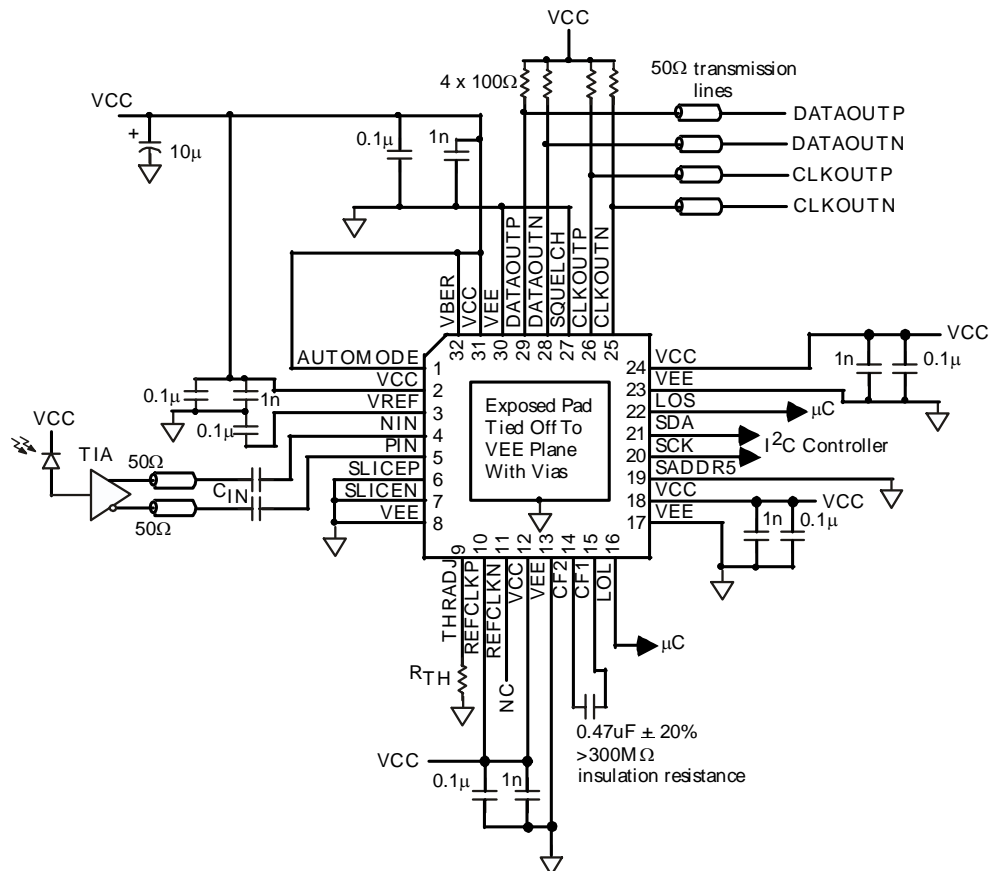

Figure 24. Typical ADN2817/ADN2818 Applications Circuit

Transmission Lines

Use of 50 Ω transmission lines is required for all high frequency input and output signals to minimize reflections: PIN, NIN, CLKOUTP, CLKOUTN, DATAOUTP, DATAOUTN (also REFCLKP, REFCLKN, if a high frequency reference clock is used, such as 155 MHz). It is also necessary for the PIN/NIN input traces to be matched in length, and the CLKOUTP/N and DATAOUTP/N output traces to be matched in length to avoid skew between the differential traces. All high speed CML outputs, CLKOUTP/N and DATAOUTP/N, also require 100 Ω back termination chip resistors connected between the output pin and VCC. These resistors should be placed as close as possible to the output pins. These 100 Ω resistors are in parallel with on-chip 100 Ω termination resistors to create a 50 Ω back termination (see Figure 25).

The high speed inputs, PIN and NIN, are internally terminated with 50 Ω to an internal reference voltage (see Figure 26). A 0.1 μF is recommended between VREF, Pin 3, and GND to provide an ac ground for the inputs.

As with any high speed mixed-signal design, take care to keep all high speed digital traces away from sensitive analog nodes.

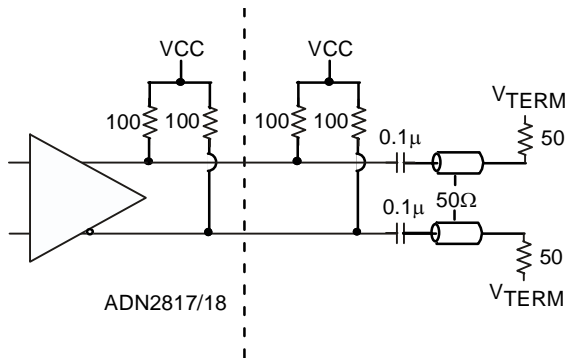

Figure 25. Typical ADN2817/ADN2818 Applications Circuit

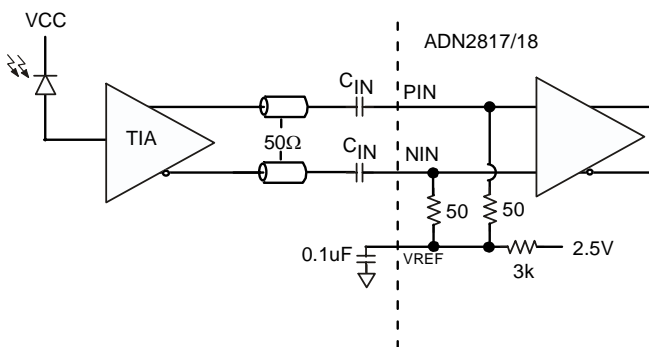

Figure 26. ADN2817/ADN2818 AC-Coupled Input Configuration

Soldering Guidelines for Chip Scale Package

The lands on the 32 LFCSP are rectangular. The printed circuit board pad for these should be 0.1 mm longer than the package land length and 0.05 mm wider than the package land width. The land should be centered on the pad. This ensures that the solder joint size is maximized. The bottom of the chip scale

package has a central exposed pad. The pad on the printed circuit board should be at least as large as this exposed pad. The user must connect the exposed pad to VEE using plugged vias so that solder does not leak through the vias during reflow. This ensures a solid connection from the exposed pad to VEE.

Choosing AC Coupling Capacitors

AC coupling capacitors at the input (PIN, NIN) and output (DATAOUTP, DATAOUTN) of the ADN2817/ADN2818 must be chosen such that the device works properly over the full range of data rates used in the application. When choosing the capacitors, the time constant formed with the two 50 Ω resistors in the signal path must be considered. When a large number of consecutive identical digits (CIDs) are applied, the capacitor voltage can droop due to baseline wander (see Figure 27), causing pattern-dependent jitter (PDJ).

The user must determine how much droop is tolerable and choose an ac coupling capacitor based on that amount of droop. The amount of PDJ can then be approximated based on the capacitor selection. The actual capacitor value selection may require some trade-offs between droop and PDJ.

Example: Assuming that 2% droop can be tolerated, then the maximum differential droop is 4%. Normalizing to V_{pp} :

$$\text{Droop} = \Delta V = 0.04 V = 0.5 V_{pp} (1 - e^{-t/\tau}); \text{ therefore, } \tau = 12t$$

where:

τ is the RC time constant (C is the ac coupling capacitor, R = 100 Ω seen by C).

t is the total discharge time, which is equal to nT.

n is the number of CIDs.

T is the bit period.

The capacitor value can then be calculated by combining the equations for τ and t:

$$C = 12nT/R$$

Once the capacitor value is selected, the PDJ can be approximated as

$$PDJ_{pspp} = 0.5t_r (1 - e^{(-nT/RC)}) / 0.6$$

where:

PDJ_{pspp} is the amount of pattern-dependent jitter allowed; < 0.01 UI p-p typical.

t_r is the rise time, which is equal to $0.22/BW$, where $BW \sim 0.7$ (bit rate).

Note that this expression for t_r is accurate only for the inputs. The output rise time for the ADN2817/ADN2818 is ~100 ps regardless of data rate.

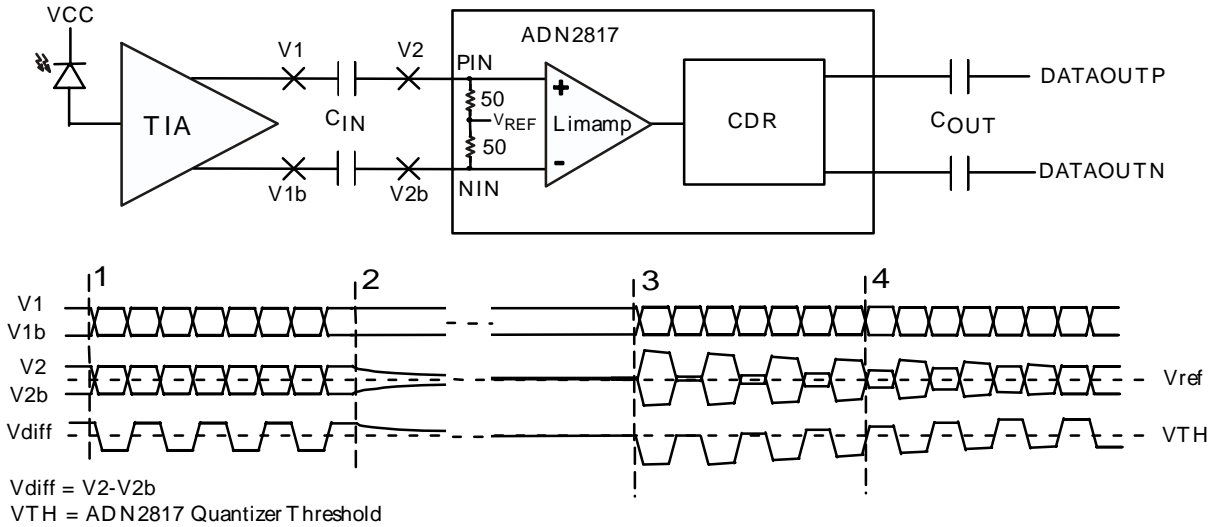

NOTES:

1. During data patterns with high transition density, differential DC voltage at V1 and V2 is zero.
2. When the output of the TIA goes to CID, V1 and V1b are driven to different DC levels. V2 and V2b discharge to the Vref level which effectively introduces a differential DC offset across the AC coupling capacitors.
3. When the burst of data starts again, the differential DC offset across the AC coupling capacitors is applied to the input levels causing a DC shift in the differential input. This shift is large enough such that one of the states, either HI or LO depending on the levels of V1 and V1b when the TIA went to CID, is cancelled out. The quantizer will not recognize this as a valid state.
4. The DC offset slowly discharges until the differential input voltage exceeds the sensitivity of the ADN2817. The quantizer will be able to recognize both HI and LO states at this point.

Figure 27. Example of Baseline Wander

DC-COUPLED APPLICATION

The inputs to the ADN2817/ADN2818 can also be dc-coupled. This might be necessary in burst mode applications, where there are long periods of CIDs, and baseline wander cannot be tolerated. If the inputs to the ADN2817/ADN2818 are dc-coupled, care must be taken not to violate the input range and common-mode level requirements of the ADN2817/ADN2818 (see Figure 28 through Figure 30). If dc coupling is required, and the output levels of the TIA do not adhere to the levels shown in Figure 29, then level shifting and/or an attenuator must be between the TIA outputs and the ADN2817/ADN2818 inputs.

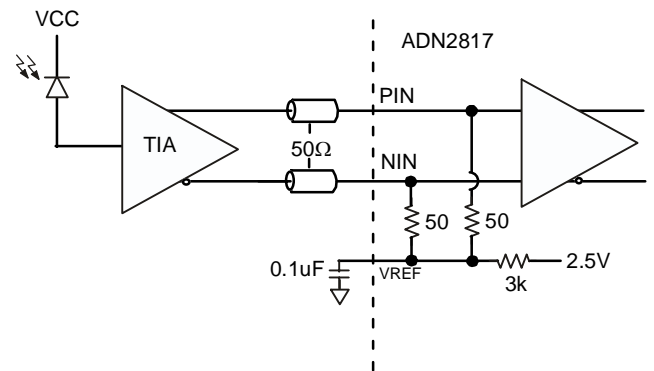

Figure 28. DC-Coupled Application

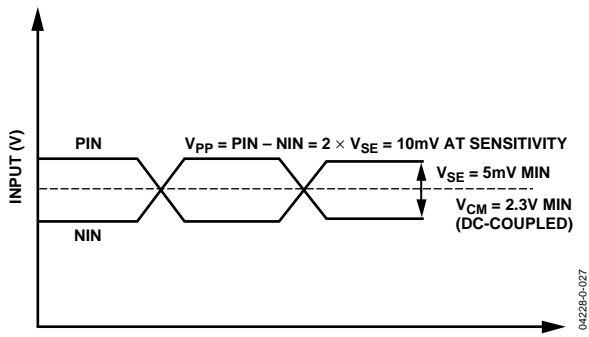

Figure 29. Minimum Allowed DC-Coupled Input Levels

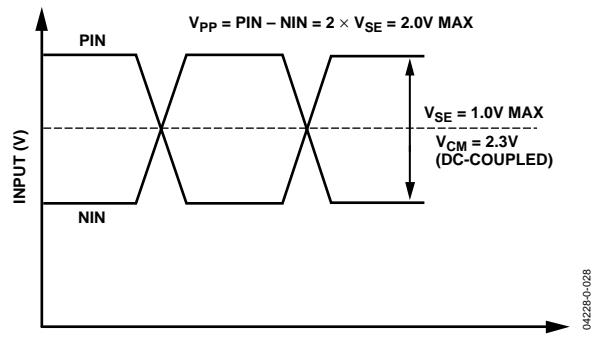

Figure 30. Maximum Allowed DC-Coupled Input Levels

COARSE DATA RATE READBACK LOOK-UP TABLE

Code is the 9-bit value read back from COARSE_RD[8:0].

Table 14. Look-Up Table

Code	F _{MID}	Code	F _{MID}	Code	F _{MID}	Code	F _{MID}
0	5.1934e+06	48	1.4828e+07	96	4.1547e+07	144	1.1862e+08
1	5.1930e+06	49	1.4827e+07	97	4.1544e+07	145	1.1862e+08
2	5.2930e+06	50	1.5121e+07	98	4.2344e+07	146	1.2097e+08
3	5.3989e+06	51	1.5435e+07	99	4.3191e+07	147	1.2348e+08
4	5.5124e+06	52	1.5770e+07	100	4.4099e+07	148	1.2616e+08
5	5.6325e+06	53	1.6127e+07	101	4.5060e+07	149	1.2901e+08
6	5.7612e+06	54	1.6510e+07	102	4.6090e+07	150	1.3208e+08
7	5.8995e+06	55	1.6917e+07	103	4.7196e+07	151	1.3534e+08
8	6.0473e+06	56	1.7357e+07	104	4.8378e+07	152	1.3885e+08
9	6.2097e+06	57	1.7836e+07	105	4.9678e+07	153	1.4269e+08
10	6.3819e+06	58	1.8347e+07	106	5.1055e+07	154	1.4678e+08
11	6.5675e+06	59	1.8896e+07	107	5.2540e+07	155	1.5117e+08
12	6.7688e+06	60	1.9493e+07	108	5.4150e+07	156	1.5594e+08
13	6.9874e+06	61	2.0136e+07	109	5.5899e+07	157	1.6109e+08
14	7.2262e+06	62	2.0833e+07	110	5.7810e+07	158	1.6667e+08
15	7.4863e+06	63	2.1582e+07	111	5.9890e+07	159	1.7266e+08
16	7.7413e+06	64	2.0774e+07	112	5.9311e+07	160	1.6619e+08
17	7.7413e+06	65	2.0772e+07	113	5.9308e+07	161	1.6617e+08
18	7.5606e+06	66	2.1172e+07	114	6.0485e+07	162	1.6938e+08
19	7.7173e+06	67	2.1596e+07	115	6.1739e+07	163	1.7277e+08
20	7.8852e+06	68	2.2049e+07	116	6.3081e+07	164	1.7640e+08
21	8.0633e+06	69	2.2530e+07	117	6.4506e+07	165	1.8024e+08
22	8.2548e+06	70	2.3045e+07	118	6.6038e+07	166	1.8436e+08
23	8.4586e+06	71	2.3598e+07	119	6.7669e+07	167	1.8878e+08
24	8.6784e+06	72	2.4189e+07	120	6.9427e+07	168	1.9351e+08
25	8.9180e+06	73	2.4839e+07	121	7.1344e+07	169	1.9871e+08
26	9.1736e+06	74	2.5527e+07	122	7.3388e+07	170	2.0422e+08
27	9.4481e+06	75	2.6270e+07	123	7.5585e+07	171	2.1016e+08
28	9.7464e+06	76	2.7075e+07	124	7.7971e+07	172	2.1660e+08
29	1.0068e+07	77	2.7950e+07	125	8.0546e+07	173	2.2360e+08
30	1.0417e+07	78	2.8905e+07	126	8.3333e+07	174	2.3124e+08
31	1.0791e+07	79	2.9945e+07	127	8.6328e+07	175	2.3956e+08
32	1.0387e+07	80	2.9655e+07	128	8.3095e+07	176	2.3724e+08
33	1.0386e+07	81	2.9654e+07	129	8.3087e+07	177	2.3723e+08
34	1.0586e+07	82	3.0242e+07	130	8.4689e+07	178	2.4194e+08
35	1.0798e+07	83	3.0869e+07	131	8.6383e+07	179	2.4695e+08
36	1.1025e+07	84	3.1541e+07	132	8.8198e+07	180	2.5233e+08
37	1.1265e+07	85	3.2253e+07	133	9.0120e+07	181	2.5802e+08
38	1.1522e+07	86	3.3019e+07	134	9.2179e+07	182	2.6415e+08
39	1.1799e+07	87	3.3834e+07	135	9.4392e+07	183	2.7067e+08
40	1.2095e+07	88	3.4714e+07	136	9.6757e+07	184	2.7771e+08
41	1.2419e+07	89	3.5672e+07	137	9.9356e+07	185	2.8538e+08
42	1.2764e+07	90	3.6694e+07	138	1.0211e+08	186	2.9355e+08
43	1.3135e+07	91	3.7792e+07	139	1.0508e+08	187	3.0234e+08
44	1.3538e+07	92	3.8985e+07	140	1.0830e+08	188	3.1188e+08
45	1.3975e+07	93	4.0273e+07	141	1.1180e+08	189	3.2218e+08
46	1.4452e+07	94	4.1666e+07	142	1.1562e+08	190	3.3333e+08
47	1.4973e+07	95	4.3164e+07	143	1.1978e+08	191	3.4531e+08

Code	F _{MID}	Code	F _{MID}	Code	F _{MID}	Code	F _{MID}
192	3.3238e+08	216	5.5542e+08	240	9.4898e+08	264	1.5481e+09
193	3.3235e+08	217	5.7075e+08	241	9.4893e+08	265	1.5897e+09
194	3.3876e+08	218	5.8711e+08	242	9.6776e+08	266	1.6338e+09
195	3.4553e+08	219	6.0468e+08	243	9.8782e+08	267	1.6813e+09
196	3.5279e+08	220	6.2377e+08	244	1.0093e+09	268	1.7328e+09
197	3.6048e+08	221	6.4437e+08	245	1.0321e+09	269	1.7888e+09
198	3.6872e+08	222	6.6666e+08	246	1.0566e+09	270	1.8499e+09
199	3.7757e+08	223	6.9062e+08	247	1.0827e+09	271	1.9165e+09
200	3.8703e+08	224	6.6476e+08	248	1.1108e+09	272	1.8980e+09
201	3.9742e+08	225	6.6470e+08	249	1.1415e+09	273	1.8979e+09
202	4.0844e+08	226	6.7751e+08	250	1.1742e+09	274	1.9355e+09
203	4.2032e+08	227	6.9106e+08	251	1.2094e+09	275	1.9756e+09
204	4.3320e+08	228	7.0558e+08	252	1.2475e+09	276	2.0186e+09
205	4.4719e+08	229	7.2096e+08	253	1.2887e+09	277	2.0642e+09
206	4.6248e+08	230	7.3743e+08	254	1.3333e+09	278	2.1132e+09
207	4.7912e+08	231	7.5514e+08	255	1.3812e+09	279	2.1654e+09
208	4.7449e+08	232	7.7405e+08	256	1.3295e+09	280	2.2217e+09
209	4.7447e+08	233	7.9485e+08	257	1.3294e+09	281	2.2830e+09
210	4.8388e+08	234	8.1688e+08	258	1.3550e+09	282	2.3484e+09
211	4.9391e+08	235	8.4064e+08	259	1.3821e+09	283	2.4187e+09
212	5.0465e+08	236	8.6640e+08	260	1.4112e+09	284	2.4951e+09
213	5.1605e+08	237	8.9438e+08	261	1.4419e+09	285	2.5775e+09
214	5.2831e+08	238	9.2496e+08	262	1.4749e+09	286	2.6666e+09
215	5.4135e+08	239	9.5825e+08	263	1.5103e+09	287	2.7625e+09

OUTLINE DIMENSIONS

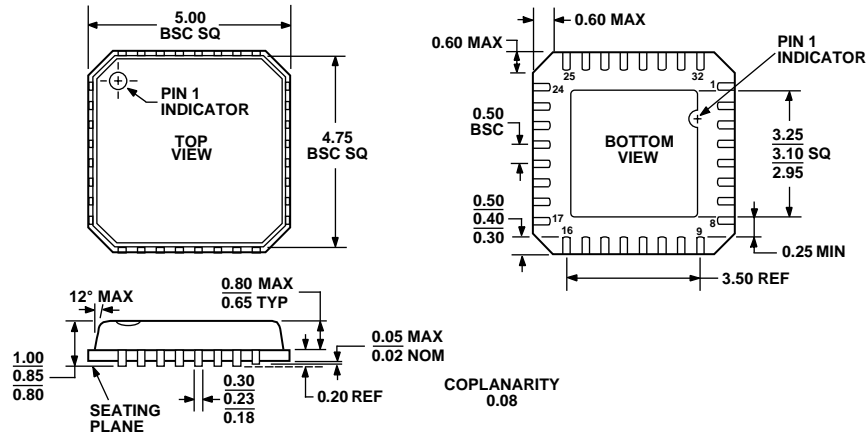

COMPLIANT TO JEDEC STANDARDS MO-220-VHHD-2

Figure 31. 32-Lead Frame Chip Scale Package [LFCSP] (CP-32)
Dimensions shown in millimeters

ORDERING GUIDE

Model	Temperature Range	Package Description	Package Option
ADN2817/ADN2818ACP	-40°C to 85°C	32-LFCSP	CP-32
ADN2817/ADN2818ACP-RL	-40°C to 85°C	32-LFCSP, tape-reel, 2500 pcs	CP-32
ADN2817/ADN2818ACP-RL7	-40°C to 85°C	32-LFCSP, tape-reel, 1500 pcs	CP-32

NOTES

NOTES

Purchase of licensed I²C components of Analog Devices or one of its sublicensed Associated Companies conveys a license for the purchaser under the Philips I²C Patent Rights to use these components in an I²C system, provided that the system conforms to the I²C Standard Specification as defined by Philips.