

# Industrial V/I Converter and Protector IC AM462

## PRINCIPLE FUNCTION

Conversion of input voltage referenced to ground to output current  
 Integrated protection for IC and external components  
 Integrated, adjustable current/voltage sources for external components

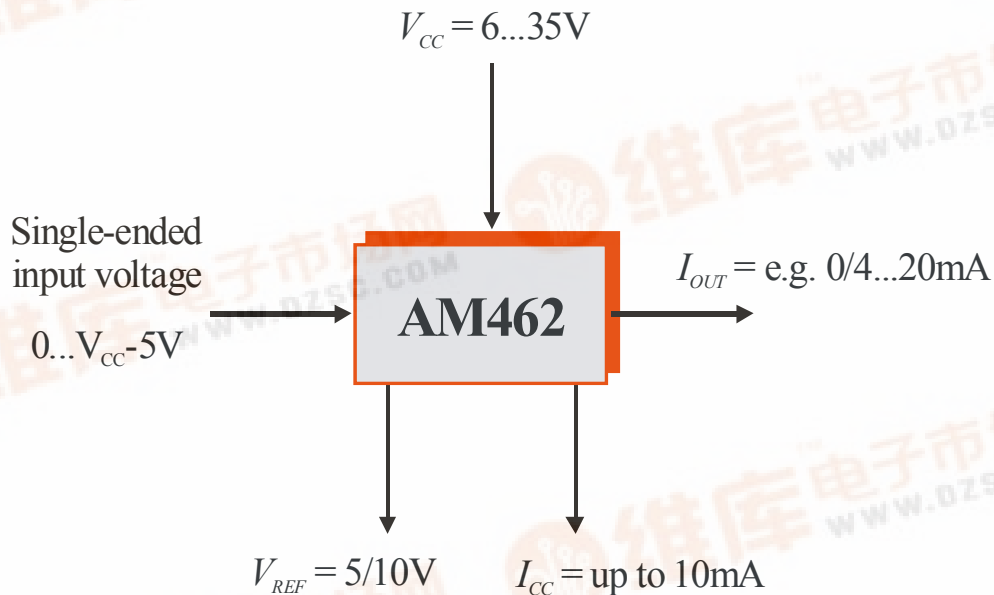

## TYPICAL APPLICATIONS

- Adjustable voltage-to-current (V/I) converter
- Adjustable voltage and current source (supply unit)
- Voltage regulator with additional functions
- Industrial protector and output IC for microprocessors (the Frame ASIC concept [1])
- Peripheral processor IC
- For examples of typical applications see *Example Applications*

# Industrial V/I Converter and Protector IC AM462

## CONTENTS

<b>CONTENTS</b>	<b>2</b>
<b>FEATURES</b>	<b>3</b>
<b>GENERAL DESCRIPTION</b>	<b>3</b>
<b>BLOCK DIAGRAM</b>	<b>3</b>
<b>ELECTRICAL SPECIFICATIONS</b>	<b>4</b>
<b>BOUNDARY CONDITIONS</b>	<b>6</b>
<b>DETAILED DESCRIPTION OF FUNCTIONS</b>	<b>6</b>
<b>INITIAL OPERATION OF AM462</b>	<b>6</b>
General information on 2- and 3-wire applications and the use of current	6
Setting the output current range	6
Selecting the supply voltage	6
Using OP2 as a current source	6
Using OP2 as a voltage reference	6
<b>POINTS TO NOTE: INITIAL OPERATION OF AM462</b>	<b>6</b>
<b>APPLICATIONS</b>	<b>6</b>
Typical 3-wire application with an input signal referenced to ground	6
Typical 2-wire application with an input signal referenced to ground	6
Application for an input signal with an offset	6
<b>BLOCK DIAGRAM AND PINOUT</b>	<b>6</b>
<b>EXAMPLE APPLICATIONS</b>	<b>6</b>
<b>DELIVERY</b>	<b>6</b>
<b>PACKAGE DIMENSIONS</b>	<b>6</b>
<b>FURTHER READING</b>	<b>6</b>

# Industrial V/I Converter and Protector IC AM462

## FEATURES

- Supply voltage: 6...35V
- Wide working temperature range:  $-40^{\circ}\text{C} \dots +85^{\circ}\text{C}$
- Adjustable integrated reference voltage source: 4.5 to 10V
- Additional voltage/current source
- Adjustable amplification
- Adjustable offset
- Industrial current output (e.g. 0/4...20mA)
- Protection against reverse polarity
- Short-circuit protection
- Output current limitation
- Low-cost device: replaces a number of discrete elements
- 2- and 3-wire operation
- Individually configurable function modules
- RoHS compliant

## GENERAL DESCRIPTION

AM462 is a universal V/I converter and amplifier IC with a number of additional functions. The IC basically consists of an amplifier, whose gain can be set externally, and an output stage which can convert voltage signals referenced to ground to industrial current signals. An additional reference voltage source for the supply of external components is also included in the device. A further operational amplifier can be connected up as a current source, voltage reference or comparator.

One of the main features of the IC is its integrated protective circuitry. The device is protected against reverse polarity and has a built-in output current limit. Converter IC AM462 enables industrial current loop signals (e.g. of 0/4–20mA) to be produced relatively easily.

Using the Frame ASIC concept [1] the IC can be connected up to a processor for signal correction.

## BLOCK DIAGRAM

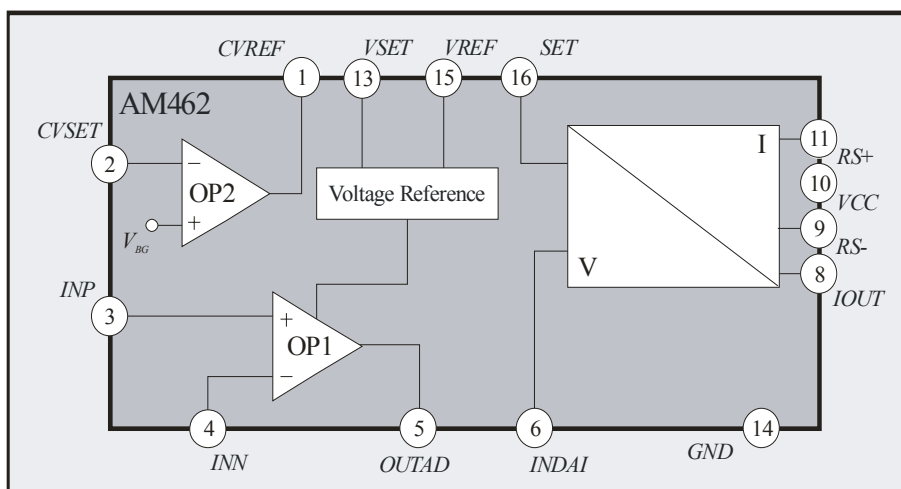

Figure 1: Block diagram of AM462 (individually configurable function modules)

# Industrial V/I Converter and Protector IC AM462

## ELECTRICAL SPECIFICATIONS

$T_{amb} = 25^{\circ}\text{C}$ ,  $V_{CC} = 24\text{V}$ ,  $V_{REF} = 5\text{V}$ ,  $I_{REF} = 1\text{mA}$  (unless otherwise stated); currents flowing into the IC are negative.

Parameter	Symbol	Conditions	Min.	Typ.	Max.	Unit
Supply Voltage Range	$V_{CC}$		6		35	V
Quiescent Current	$I_{CC}$	$T_{amb} = -40\dots+85^{\circ}\text{C}$ , $I_{REF} = 0\text{mA}$			1.5	mA
<b>Temperature Specifications</b>						
Operating	$T_{amb}$		-40		85	$^{\circ}\text{C}$
Storage	$T_{st}$		-55		125	$^{\circ}\text{C}$
Junction	$T_j$				150	$^{\circ}\text{C}$
Thermal Resistance	$\Theta_{ja}$	DIL16 plastic package		70		$^{\circ}\text{C}/\text{W}$
	$\Theta_{ja}$	SO16 narrow plastic package		140		$^{\circ}\text{C}/\text{W}$
<b>Voltage Reference</b>						
Voltage	$V_{REF}$	$V_{SET}$ not connected	4.75	5.00	5.25	V
	$V_{REF10}$	$V_{SET} = GND$ , $V_{CC} \geq 11\text{V}$	9.5	10.0	10.5	V
Trim Range	$V_{REFADJ}$		4.5		$V_{REF10}$	V
Current	$I_{REF}^*$		0		10.0	mA
$V_{REF}$ vs. Temperature	$dV_{REF}/dT$	$T_{amb} = -40\dots+85^{\circ}\text{C}$		$\pm 90$	$\pm 140$	ppm/ $^{\circ}\text{C}$
Line Regulation	$dV_{REF}/dV$	$V_{CC} = 6\text{V}\dots 35\text{V}$		30	80	ppm/V
	$dV_{REF}/dV$	$V_{CC} = 6\text{V}\dots 35\text{V}$ , $I_{REF} \approx 5\text{mA}$		60	150	ppm/V
Load Regulation	$dV_{REF}/dI$			0.05	0.10	%/mA
	$dV_{REF}/dI$	$I_{REF} \approx 5\text{mA}$		0.06	0.15	%/mA
Load Capacitance	$C_L$		1.9	2.2	5.0	$\mu\text{F}$
<b>Current/Voltage Source OP2</b>						
Internal Reference	$V_{BG}$		1.20	1.27	1.35	V
$V_{BG}$ vs. Temperature	$dV_{BG}/dT$	$T_{amb} = -40\dots+85^{\circ}\text{C}$		$\pm 60$	$\pm 140$	ppm/ $^{\circ}\text{C}$
Current Source: $I_{CV} = V_{BG}/R_{SET}$ , from Figure 5						
Adjustable Current Range	$I_{CV}^*$		0		10	mA
Output Voltage	$V_{CV}$	$V_{CC} < 19\text{V}$	$V_{BG}$		$V_{CC} - 4$	V
	$V_{CV}$	$V_{CC} \geq 19\text{V}$	$V_{BG}$		15	V
Voltage Source: $V_{CV} = V_{BG} (1 + R_7 / R_6)$ , from Figure 6						
Adjustable Voltage Range	$V_{CV}$	$V_{CC} < 19\text{V}$	0.4		$V_{CC} - 4$	V
	$V_{CV}$	$V_{CC} \geq 19\text{V}$	0.4		15	V
Output Current	$I_{CV}^*$	Source			10	mA
	$I_{CV}$	Sink			-100	$\mu\text{A}$
Load Capacitance	$C_L$	Source mode	0	1	10	nF
<b>Operational Amplifier Gain Stage (OP1)</b>						
Adjustable Gain	$G_{GAIN}$		1			
Input Range	$I_R$	$V_{CC} < 10\text{V}$	0		$V_{CC} - 5$	V
	$I_R$	$V_{CC} \geq 10\text{V}$	0		5	V
Power Supply Rejection Ratio	$PSRR$		80	90		dB
Offset Voltage	$V_{OS}$			$\pm 0.5$	$\pm 2$	mV

# Industrial V/I Converter and Protector IC

## AM462

Parameter	Symbol	Conditions	Min.	Typ.	Max.	Unit
<b>Operational Amplifier Gain Stage (OP1) (cont.)</b>						
$V_{OS}$ vs. Temperature	$dV_{OS}/dT$			±3	±7	μV/°C
Input Bias Current	$I_B$			10	25	nA
$I_B$ vs. Temperature	$dI_B/dT$			7	20	pA/°C
Output Voltage Limitation	$V_{LIM}$			$V_{REF}$		V
Output Voltage Range	$V_{OUTAD}$	$V_{CC} < 10V$	0		$V_{CC} - 5$	V
	$V_{OUTAD}$	$V_{CC} \geq 10V$	0		$V_{REF}$	V
Load Capacitance	$C_L$				250	pF
<b>V/I Converter</b>						
Internal Gain	$G_{VI}$		0,12	0.125	0,13	
Trim Range		Adjustable by $R_0$	0.75	1.00	1.25	
Voltage Range at $R_0$ FS	$V_{R0FS}$		350		750	mV
Offset Voltage	$V_{OS}$	□ <sub>F</sub> ≥ 100		±2	±4	mV
$V_{OS}$ vs. Temperature	$dV_{OS}/dT$	□ <sub>F</sub> ≥ 100		±7	±14	μV/°C
Input Resistance	$R_{IN}$		120	160		kΩ
$R_{IN}$ vs. Temperature	$dR_{IN}/dT$		0.2	0.3		kΩ/°C
Output Offset Current	$I_{OUTOS}$	3-wire operation		-25	-35	μA
$I_{OUTOS}$ vs. Temperature	$dI_{OUTOS}/dT$	3-wire operation		16	26	nA/°C
Output Offset Current	$I_{OUTOS}$	2-wire operation		9.5	14	μA
$I_{OUTOS}$ vs. Temperature	$dI_{OUTOS}/dT$	2-wire operation		6	8	nA/°C
Output Control Current	$I_{OUTC}$	2-wire operation, $V_{R0}/100mV$		6	8	μA
$I_{OUTC}$ vs. Temperature	$dI_{OUTC}/dT$	2-wire operation		-10	-15	nA/°C
Output Voltage Range	$V_{OUT}$	$V_{OUT} = R_L I_{OUT}, V_{CC} < 18V$	0		$V_{CC} - 6$	V
	$V_{OUT}$	$V_{OUT} = R_L I_{OUT}, V_{CC} \geq 18V$	0		12	V
Output Current Range FS	$I_{OUTFS}$	$I_{OUT} = V_{R0}/R_0, 3\text{-wire operation}$		20		mA
Output Resistance	$R_{OUT}$		0.5	1.0		MΩ
Load Capacitance	$C_L$		0		500	nF
<b>SET Stage</b>						
Internal Gain	$G_{SET}$			0.5		
Input Voltage	$V_{SET}$		0		1.15	V
Offset Voltage	$V_{OS}$			±0.5	±1.5	mV
$V_{OS}$ vs. Temperature	$dV_{OS}/dT$			±1.6	±5	μV/°C
Input Bias Current	$I_B$			8	20	nA
$I_B$ vs. Temperature	$dI_B/dT$			7	18	pA/°C
<b>Protection Functions</b>						
Voltage Limitation at $R_0$	$V_{LIMRO}$	$V_{INDAI} = 0, V_{R0} = G_{SET} V_{SET}$	580	635	690	mV
Protection against reverse polarity		Ground vs. $V_S$ vs. $V_{OUT}$			35	V
		Ground vs. $V_S$ vs. $I_{OUT}$			35	V
Current in the event of reverse polarity		Ground = 35V, $V_S = I_{OUT} = 0$		4.5		mA
<b>System Parameters</b>						
Nonlinearity		Ideal input		0.05	0.15	%FS

\* In 2-wire operation a maximum current of  $I_{OUTmin} - I_{CC}$  is valid

# Industrial V/I Converter and Protector IC AM462

## BOUNDARY CONDITIONS

Parameter	Symbol	Conditions	Min.	Typ.	Max.	Unit
Sense Resistor	$R_0$	$I_{OUTFS} = 20\text{mA}$	17	27	38	$\square$
	$R$	$c = 20\text{mA}/I_{OUTFS}$	$c \cdot 17$	$c \cdot 27$	$c \cdot 38$	$\square$
Stabilization Resistor	$R_{\square}$	$I_{OUTFS} = 20\text{mA}$	35	40	45	$\square$
	$R_{\square}$	$c = 20\text{mA}/I_{OUTFS}$	$c \cdot 35$	$c \cdot 40$	$c \cdot 45$	$\square$
Load Resistance	$R_L$	Limitation only for 3-wire operation	0		600	$\square$
Sum Gain Resistors	$R_1 + R_2$		20		200	$\text{k}\square$
Sum Offset Resistors	$R_3 + R_4$		20		200	$\text{k}\square$
$V_{REF}$ Capacitance	$C_1$	Ceramic	1.9	2.2	5.0	$\mu\text{F}$
Output Capacitance	$C_2$	Only for 2-wire operation	90	100	250	$\text{nF}$
$D_1$ Breakdown Voltage	$V_{BR}$		35	50		V
$T_1$ Forward Current Gain	$\square_F$	BCX54/55/56, for example	50	150		

## DETAILED DESCRIPTION OF FUNCTIONS

AM462 is a modular, universal V/I converter and protector IC which has been specially developed for the conditioning of voltage signals referenced to ground. It is designed for both 2- and 3-wire operation in industrial applications (cf. application in Figure 8). AM462's various functions are depicted in the block diagram (Figure 2) which also illustrates how few external components are required for the operation of this particular device.

AM462 consists of several modular function blocks (operational amplifiers, voltage-to-current converters and references) which, depending on external configurations, can either be switched to one another or operated separately (see the basic circuitry in Figure 2):

1. *Operational amplifier stage* OP1 enables a positive voltage signal to be amplified. OP1 gain  $G_{GAIN}$  can be set via external resistors  $R_1$  and  $R_2$ . Protective circuitry against overvoltage is integrated into the chip, limiting the voltage to the set value of the reference voltage. Output voltage  $V_{OUTAD}$  at pin *OUTAD* is calculated as:

$$V_{OUTAD} = V_{INP} \cdot G_{GAIN} \quad \text{with} \quad G_{GAIN} = 1 + \frac{R_1}{R_2} \quad (1)$$

where  $V_{INP}$  is the voltage at OP1's input pin *INP*.

2. The internal voltage-to-current converter (V/I converter) provides a voltage-controlled current signal at IC output *IOUT* (pin 8) which activates an external transistor  $T_1$ ; this in turn supplies the actual output current  $I_{OUT}$ . To reduce power dissipation the transistor is an external component and protected against reverse polarity by an additional diode  $D_1$ . Via pin *SET* an offset current  $I_{SET}$  can be set at output *IOUT* (with the help of the internal voltage reference and an external voltage divider as shown in Figure 2, for example). External resistor  $R_0$  permits the output current to be finely adjusted with parallel operation of current and the voltage output. For the output current provided by  $T_1$  the following ratio applies:

# Industrial V/I Converter and Protector IC AM462

$$I_{OUT} = \frac{V_{INDAI}}{8R_0} + I_{SET} \quad \text{with} \quad I_{SET} = \frac{V_{SET}}{2R_0} \quad (2)$$

with  $V_{INDAI}$  the voltage at pin  $INDAI$  and  $V_{SET}$  the voltage at pin  $SET$  (V/I converter inputs)<sup>1</sup>.

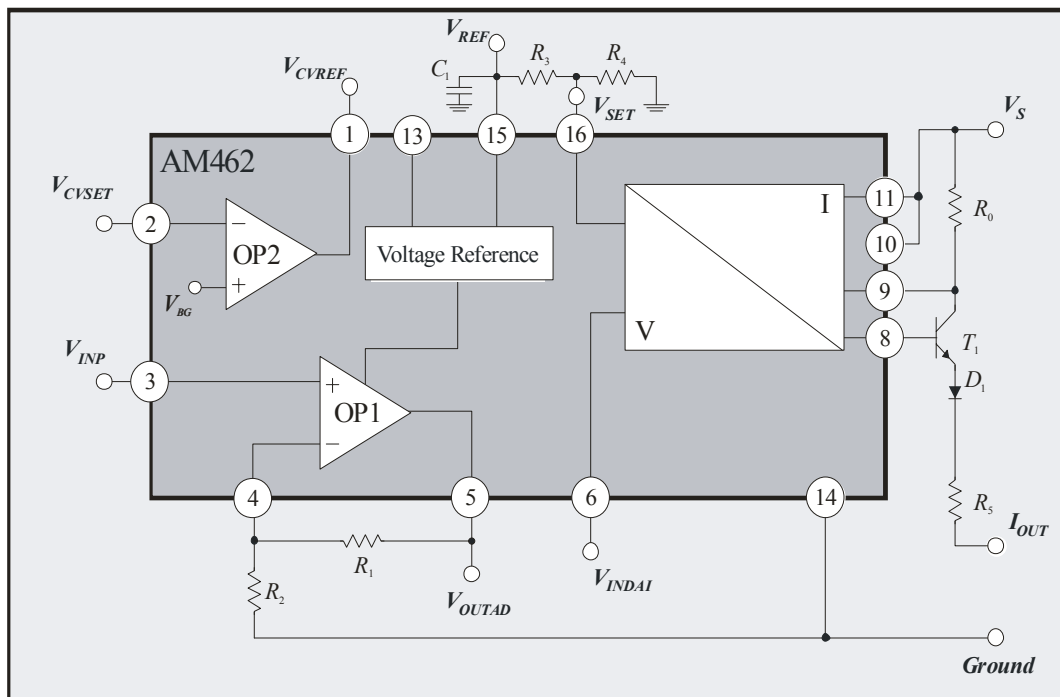

**Figure 2:** Block diagram of AM462 with external components (3-wire circuit for current output)

- The AM462 *reference voltage source* enables voltage to be supplied to external components (such as sensors, microprocessors, etc.). The reference voltage value  $V_{REF}$  can be set via pin 13  $VSET$ . If pin  $VSET$  is not connected,  $V_{REF} = 5V$ ; if  $VSET$  is switched to ground,  $V_{REF} = 10V$ . Values between the above can be set if two external resistors are used (inserted between pin  $VREF$  and pin  $VSET$  and between pin  $VSET$  and  $GND$ ; see Figure 2).

External (ceramic) capacitor  $C_1$  at pin  $VREF$  stabilizes the reference voltage. It **must** be connected even if the voltage reference is not in use.

- The additional *operational amplifier stage* OP2 can be used as a current or voltage source to supply external components. OP2's positive input is connected internally to voltage  $V_{BG}$  so that the output current or output voltage can be set across a wide range using one or two external resistors.

<sup>1</sup> The construction of the V/I converter is such that output current  $I_{OUT}$  is largely independent of the current amplification  $\beta_F$  of external transistor  $T_1$ . Production-specific variations in the current amplification of the transistors used are compensated for internally by the V/I converter.

# Industrial V/I Converter and Protector IC AM462

## INITIAL OPERATION OF AM462

### General information on 2- and 3-wire applications and the use of current

In 3-wire operation (cf. Figure 3 right and Figure 7) the ground of the IC (pin *GND*) is connected up to the external mass of the system *Ground*. The system's supply voltage  $V_S$  is connected to pin *VCC* and pin *VCC* to pin *RS+*.

In 2-wire operation (cf. Figure 3 left and Figure 7) system supply voltage  $V_S$  is connected to pin *RS+* and pin *VCC* to *RS-*. The ground of the IC (pin *GND*) is connected to the node between resistor  $R_S$  and load resistor  $R_L$  (current output  $I_{OUT}$ ). IC ground (*GND*) is **not** the same as system ground (*Ground*)!! The output signal is picked up via load resistor  $R_L$  which connects current output  $I_{OUT}$  to the system ground.

In 2-wire operation the IC ground is "virtual" (floating), as with a constant load resistance the supply voltage of the device  $V_{CC}$  changes according to the current. As a rule, the following equation applies to 2-wire operation:

$$V_{CC} = V_S - I_{OUT}(V_{IN}) R_L \quad (2)$$

The reason for this is that in 2-wire operation the IC is connected in series to the actual load resistor  $R_L$ . This is illustrated in Figure 3.

In 3-wire operation  $V_{CC} = V_S$ , as the IC ground is connected to the ground of the system.

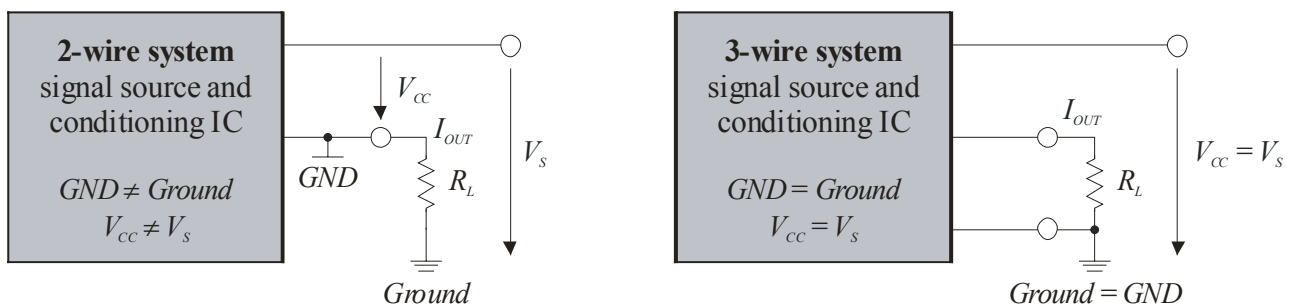

**Figure 3:** The difference between 2- and 3-wire operation

### Setting the output current range

When using amplification stage OP1 together with the V/I converter for voltage-to-current conversion the offset of the output current should first be compensated for by suitable selection of resistors  $R_3$  and  $R_4$ . To this end the OP1 input must be connected to ground ( $V_{INP} = 0$ ). With the short circuit at the input and by connecting up V/I converter pin *VSET* as shown in Figure 2 the values of the output current according to Equation 2 are as follows:



# Industrial V/I Converter and Protector IC AM462

$$I_{OUT}(V_{INDAI} = 0) = I_{SET} = \frac{V_{REF}}{2R_0} \cdot \frac{R_4}{R_3 + R_4} \quad (3)$$

and thus for the ratio of the resistors  $R_3/R_4$ :

$$\frac{R_3}{R_4} = \frac{V_{REF}}{2R_0 I_{SET}} - 1 \quad (4)$$

The output current range is set in conjunction with the selected external resistors  $R_1$  and  $R_2$  (or fine adjustment with  $R_0$ ). Using Equations 1 and 2 the following is calculated for output current  $I_{OUT}$ :

$$I_{OUT} = V_{INP} \frac{G_{GAIN}}{8R_0} + I_{SET} \quad \text{with} \quad G_{GAIN} = 1 + \frac{R_1}{R_2} \quad (5)$$

## Selecting the supply voltage

System supply voltage  $V_S$  needed to operate AM462 is dependent on the selected mode of operation.

When using current output pin  $I_{OUT}$  (in conjunction with the external transistor) the value of  $V_S$  is dependent on that of the relevant load resistor  $R_L$  (max.  $600\Omega$ ) used by the application. The minimum system supply voltage  $V_S$  is then:

$$V_S \geq I_{OUTmax} R_L + V_{CCmin} \quad (6)$$

Here,  $I_{OUTmax}$  stands for the maximum output current and  $V_{CCmin}$  for the minimum IC supply voltage which is dependent on the selected reference voltage:

$$V_{CCmin} \geq V_{REF} + 1V \quad (7)$$

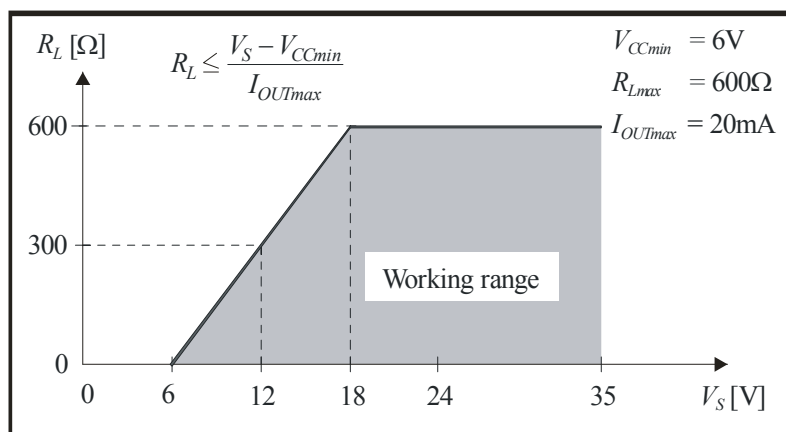

**Figure 4:** Working range in conjunction with the load resistor

# Industrial V/I Converter and Protector IC AM462

The working range resulting from Equation 6 is described in Figure 4. Example calculations and typical values for the external components can be found in the example applications from page 13 onwards.

## Using OP2 as a current source

The additional operational amplifier OP2 can easily be connected up as a constant current source. Using the circuit in Figure 5 the following applies:

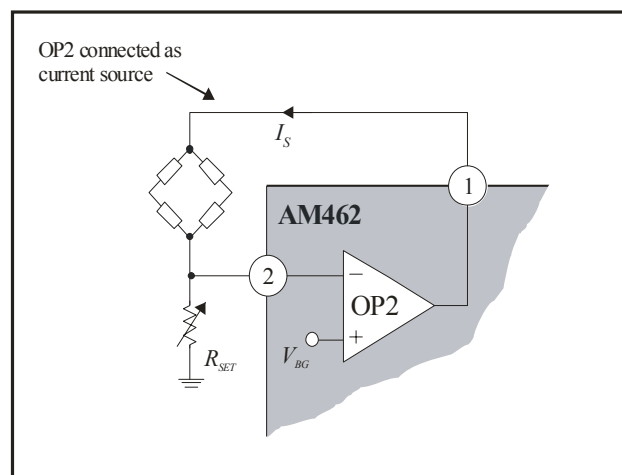

**Figure 5:** Using OP2 as a constant current source

## Example : OP2 as current source

$$I_S = \frac{V_{BG}}{R_{SET}} = \frac{1.27 \text{ V}}{R_{SET}} \quad (8)$$

The bridge symbol represents the component to be supplied with current (e.g. a piezoresistive sensing element or temperature sensor).

A supply current of  $I_S = 1 \text{ mA}$  is to be set. Using Equation 8 the following value is calculated for external resistor  $R_{SET}$ , which in turn stipulates the size of the current:

$$R_{SET} = \frac{V_{BG}}{I_S} = \frac{1.27 \text{ V}}{1 \text{ mA}} = 1.27 \text{ k}\Omega$$

# Industrial V/I Converter and Protector IC AM462

## Using OP2 as a voltage reference

In addition to the integrated voltage reference OP2 can also be used to supply voltage to external components, such as A/D converters and microprocessors, for example. Lower voltages can be generated (e.g. 3.3V) which with the increasing miniaturization of devices and need for ever lower levels of power dissipation in digital components is today of growing importance.

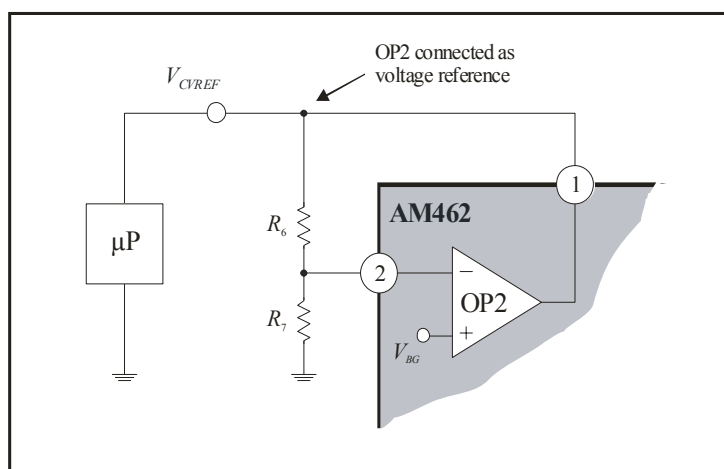

**Figure 6:** Using OP2 as a voltage reference

The additional operational amplifier OP2 can easily be connected up as a voltage reference. Using the circuit in Figure 6 the following applies:

$$V_{CVREF} = V_{BG} \left( 1 + \frac{R_6}{R_7} \right) = 1.27 \text{ V} \left( 1 + \frac{R_6}{R_7} \right) \quad (9)$$

### Example : OP2 as voltage reference

A voltage of  $V_{CVREF} = 3.3\text{V}$  is to be set. Using Equation 9 the following ratio is calculated for external resistors  $R_6$  and  $R_7$ :

$$\frac{R_6}{R_7} = \frac{V_{CVREF}}{V_{BG}} - 1 \approx 2,6 - 1 = 1,6$$

The following example values are produced for the resistors:

$$R_7 = 10\text{k}\Omega \quad R_6 = 16\text{k}\Omega$$

# Industrial V/I Converter and Protector IC AM462

## POINTS TO NOTE: INITIAL OPERATION OF AM462

1. When operating AM462 it is imperative that external capacitor  $C_1$  is **always** connected (cf. **Figure 2**). Care must be taken that the value of the capacitance does not lie beyond its given range, even across the range of temperature (see *Boundary Conditions* on page 7). In 2-wire operation ceramic capacitor  $C_2$  must also be used (cf. Figure 8).
2. In a 2-wire setup the power consumption of the overall system (AM462 plus all external components, including the configuration resistors) **must not exceed** the sum of  $I_{OUTmin}$  (usually 4mA).
3. All AM462 function blocks not required by the application must be connected to a defined (and allowed) potential.
4. A load resistance of  $600\Omega$  **maximum** is permitted for the current output.
5. The values of external resistors  $R_0, R_1, R_2, R_3, R_4$  and  $R_5$  must be selected within the permissible range given in the boundary conditions on page 7.

## APPLICATIONS

### Typical 3-wire application with an input signal referenced to ground

Figure 7 shows a 3-wire application in which AM462 amplifies and converts a positive voltage signal referenced to ground. The unused blocks (e.g. OP2) have been set to defined operating points in the application. Alternatively, these function groups can also be used here (e.g. to supply external components).

For output current  $I_{OUT}$  the following applies according to Equations 1 and 2:

$$I_{OUT} = V_{INP} \cdot \frac{G_I}{8R_0} + I_{SET} \quad \text{with } G_I = G_{GAIN} = 1 + \frac{R_1}{R_2}$$

### Example: 0...20mA Voltage-To-Current Transmitter

To obtain a signal of  $V_{INP} = 0...1V$  at the OP1 input the external components are to be dimensioned in such a way that the output current has a range of 0...20mA (i.e.  $I_{SET} = 0 \Rightarrow SET = GND$ ). With  $R_0 = 27\Omega$ :

$$I_{OUT} = V_{INP} \cdot \frac{G_I}{8R_0} + I_{SET} = V_{INP} \cdot \frac{G_{GAIN}}{8R_0}$$

The following then applies to the gain:

# Industrial V/I Converter and Protector IC AM462

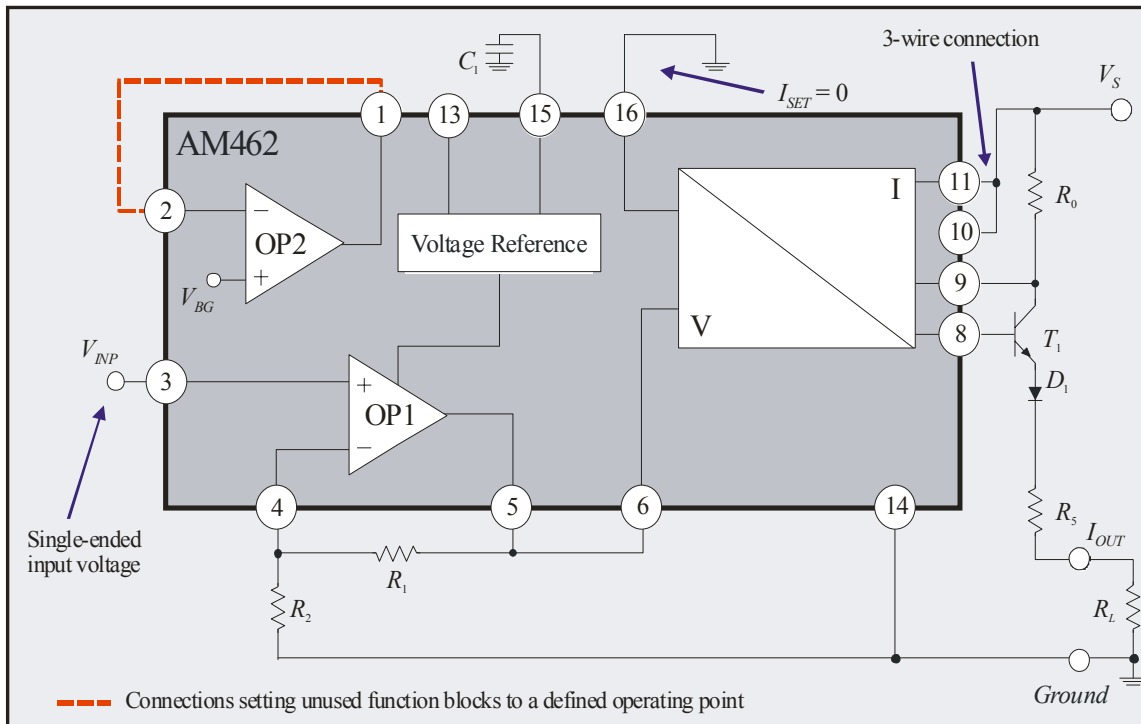

**Figure 7:** Typical application for input signals referenced to ground

$$G_{GAIN} = 8R_0 \frac{I_{OUT}}{V_{INP}} = 8 \cdot 27\Omega \cdot \frac{20\text{mA}}{1\text{V}} \approx 4.32 \Rightarrow \frac{R_1}{R_2} = 4.32 - 1 = 3.32$$

Observing the boundary conditions (page 7), the following values are obtained for the external components:

$$R_1 \approx 33.2\text{k}\Omega \quad R_2 = 10\text{k}\Omega \quad R_0 = 27\Omega \quad R_5 = 39\Omega \quad R_L = 0 \dots 600\Omega \quad C_1 = 2.2\mu\text{F}$$

## Typical 2-wire application with an input signal referenced to ground

In 2-wire operation (cf. Figure 8) system supply voltage  $V_S$  is connected up to pin  $RS+$  and pin  $VCC$  to pin  $RS-$ . The ground of the IC (pin  $GND$ ) is connected to the node between resistor  $R_5$  and load resistor  $R_L$ . IC ground ( $GND$ ) is **not** the same as system ground ( $Ground$ ). The output signal is picked up via load resistor  $R_L$  which connects current output  $I_{OUT}$  to the system ground.

It must be ensured that in 2-wire operation an additional current load (use of current/voltage source) is limited to 4mA due to the domestic current supply and limitation.

For output current  $I_{OUT}$  the following applies according to Equations 1 and 2:

$$I_{OUT} = V_{INP} \cdot \frac{G_I}{8R_0} + I_{SET} \quad \text{with} \quad G_I = G_{GAIN} = 1 + \frac{R_1}{R_2} \quad \text{and} \quad I_{SET} = \frac{V_{REF}}{2R_0} \cdot \frac{R_4}{R_3 + R_4}$$

# Industrial V/I Converter and Protector IC AM462

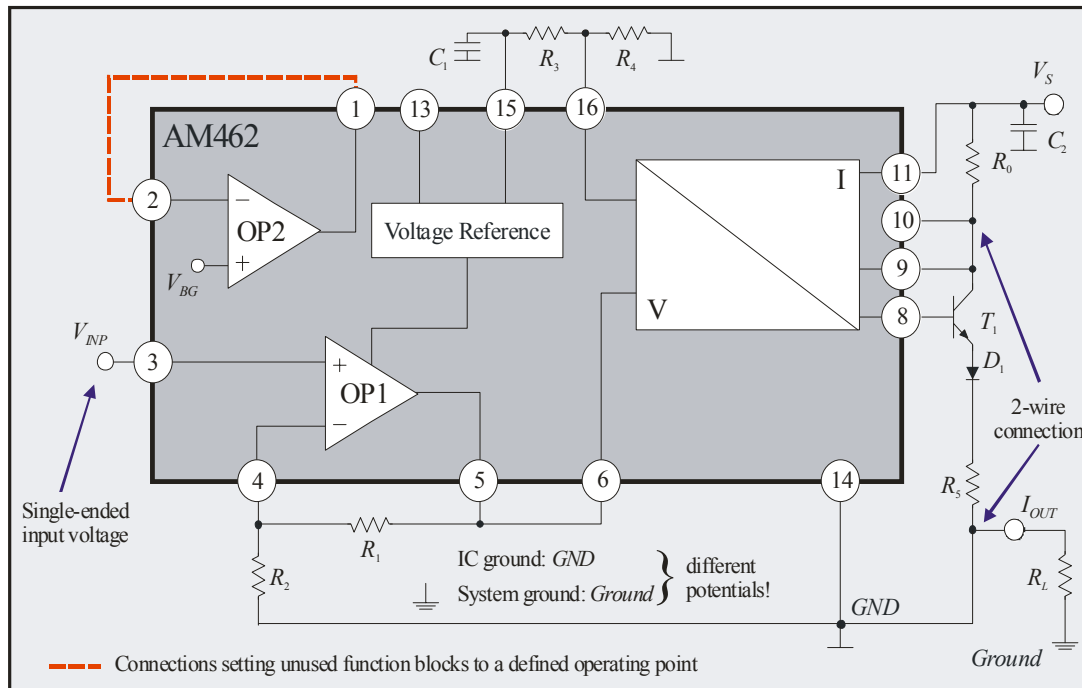

**Figure 8:** Typical 2-wire operation for input signals referenced to ground

## Example : 4...20mA Voltage-To-Current Transmitter

To obtain a signal of  $V_{INP} = 0...1V$  at the OP1 input the external components are to be dimensioned in such a way that the output current has a range of 4...20mA. The following applies:

$$I_{OUT} = V_{INP} \cdot \frac{G_I}{8R_0} + I_{SET} = V_{INP} \cdot \frac{G_{GAIN}}{8R_0} + 4mA$$

With  $R_0 = 27\Omega$  and  $I_{SET} = 4mA$  Equation 4 produces the following for resistors  $R_3$  and  $R_4$ :

$$\frac{R_3}{R_4} = \frac{V_{REF}}{2R_0 I_{SET}} - 1 = \frac{5V}{2 \cdot 27\Omega \cdot 4mA} - 1 \approx 22.15$$

and thus the following value for the gain:

$$G_{GAIN} = 8R_0 \frac{I_{OUT\max} - I_{SET}}{V_{INP}} = 8 \cdot 27\Omega \cdot \frac{16mA}{1V} = 3.456 \quad \Rightarrow \quad \frac{R_1}{R_2} = 3.456 - 1 = 2.456$$

Observing the given boundary conditions, the following values are obtained for the external components:

$$\begin{array}{llll} R_1 \approx 24.56k\Omega & R_2 = 10k\Omega & R_3 \approx 44.3k\Omega & R_4 = 2k\Omega \\ R_0 = 27\Omega & R_5 = 39\Omega & R_L = 0...600\Omega & C_1 = 2.2\mu F \quad C_2 = 100nF \end{array}$$

# Industrial V/I Converter and Protector IC AM462

## Application for an input signal with an offset

It is not uncommon for input signals to have an offset (e.g. of 0.5...4.5V or 1...6V). For signals such as these an offset current is generated at the IC output also when  $I_{SET} = 0$ . The circuit can then be dimensioned as described in the following.

According to Equation 2 the following applies for a required current swing at the output of  $\Delta I_{OUT} = I_{OUTmax} - I_{OUTmin}$ :

$$\Delta I_{OUT} = \frac{\Delta V_{PIN6}}{8R_0} \quad \Rightarrow \quad \Delta V_{PIN6} = 8R_0 \Delta I_{OUT} \quad (10)$$

For an input current swing of  $\Delta V_{IN} = V_{INmax} - V_{INmin}$  the necessary gain is calculated as:

$$G = \frac{\Delta V_{PIN6}}{\Delta V_{IN}} \quad (11)$$

If  $G < 1$ , the input signal can be routed directly to pin 6 (*INDAI*) via a voltage divider without OP1 having to be used (see Figure 9). With this circuitry the following results:

$$G = \frac{\Delta V_{PIN6}}{\Delta V_{IN}} = \frac{R_9}{R_8 + R_9} \quad \Rightarrow \quad \frac{R_8}{R_9} = \frac{\Delta V_{IN}}{\Delta V_{PIN6}} - 1 \quad (12)$$

From input offset  $V_{INmin}$  the following output current is then obtained when  $I_{SET} = 0$ :

$$I_{OUT}(V_{INmin}) = V_{INmin} \cdot \frac{R_9}{R_8 + R_9} \cdot \frac{1}{8R_0} \quad (13)$$

Using the *SET* pin and Equation 2 the required minimum output current  $I_{OUTmin}$  can then be set:

$$I_{OUT} = V_{IN} \cdot \frac{R_9}{R_8 + R_9} \cdot \frac{1}{8R_0} + I_{SET} \quad \text{with} \quad I_{SET} = \frac{V_{REF}}{2R_0} \cdot \frac{R_4}{R_3 + R_4} \quad (14)$$

## Example : 4..20mA Voltage-To-Current Transmitter with Input Signal Offset

To obtain a signal of  $V_{IN} = 0.5...4.5V$  the external components are to be dimensioned in such a way that the output current has a range of 4...20mA. The circuitry is shown in Figure 9. OP1 is not used here. It is, however, available to the user as an additional OP and can be used as an impedance converter at the voltage-to-current converter input *INDAI*, for example.

With reference to Equation 10 and with  $R_0 = 27\Omega$ , a voltage swing is obtained at pin 6 of:

$$\Delta V_{PIN6} = 8R_0 \Delta I_{OUT} = 8 \cdot 27\Omega \cdot 16mA = 3.456V$$

Using Equation 12 the following applies:

$$\frac{R_8}{R_9} = \frac{\Delta V_{IN} - \Delta V_{PIN6}}{\Delta V_{PIN6}} = \frac{4V - 3.456V}{3.456V} \approx 0.157 \quad \Rightarrow \quad R_9 = 6.35 \cdot R_8$$

# Industrial V/I Converter and Protector IC AM462

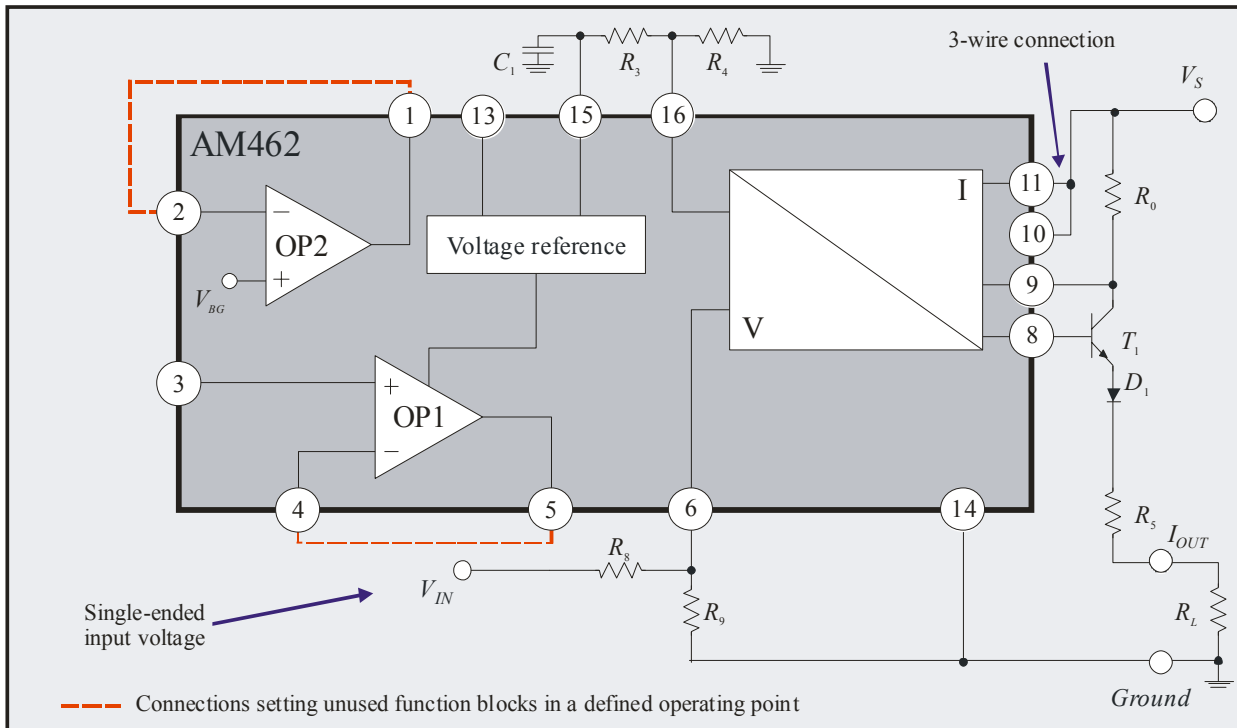

**Figure 9:** Converting an input signal with an

According to Equation 13 the minimum output current generated by the input offset is calculated as:

$$I_{OUT\min} = V_{IN\min} \cdot \frac{R_9}{R_8 + R_9} \cdot \frac{1}{8R_0} = 0.5V \cdot \frac{6,37}{6,37 + 1} \cdot \frac{1}{8 \cdot 27\Omega} \approx 2\text{mA}$$

To obtain an output current of  $I_{OUT} = 4 \dots 20\text{mA}$ , according to the above a current of  $I_{SET} = 2\text{mA}$  must then be added. With reference to Equation 4 the ratio of  $R_3$  to  $R_4$  is calculated thus:

$$I_{SET} = 2\text{mA} = \frac{V_{REF}}{2R_0} \cdot \frac{R_4}{R_3 + R_4} \Rightarrow \frac{R_3}{R_4} = \frac{V_{REF}}{2R_0 I_{SET}} - 1 = \frac{5V}{2 \cdot 27\Omega \cdot 2\text{mA}} - 1 \approx 45.3$$

Observing the given boundary conditions, the following values are obtained for the external components:

$$\begin{aligned} R_0 &\approx 27\Omega & R_8 &\approx 10\text{k}\Omega & R_9 &= 63.7\text{k}\Omega & R_3 &= 90.6\text{k}\Omega & R_4 &= 2\text{k}\Omega \\ R_5 &= 39\Omega & R_L &= 0 \dots 600\Omega & C_1 &= 2.2\mu\text{F} \end{aligned}$$



# Industrial V/I Converter and Protector IC AM462

## BLOCK DIAGRAM AND PINOUT

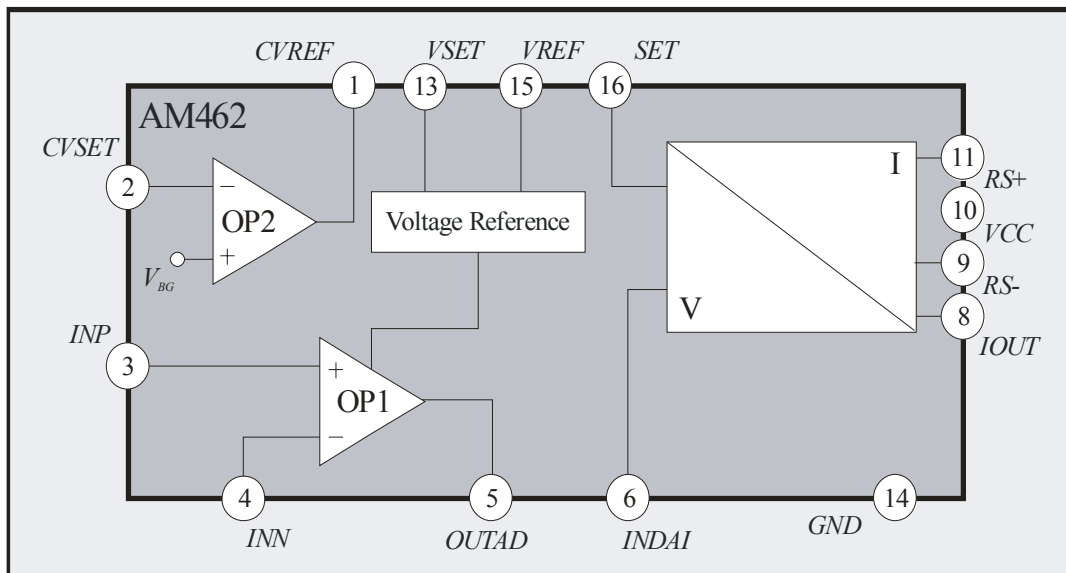

**Figure 10:** Block diagram of AM462

PIN	NAME	EXPLANATION
1	CVREF	Current/Voltage reference
2	CVSET	Current/Voltage reference set
3	INP	Positive input
4	INN	Negative input
5	OUTAD	System amplification output
6	INDAI	Current output stage input
7	N.C.	Not connected
8	IOUT	Current output
9	RS-	Sensing resistor -
10	VCC	Supply voltage
11	RS+	Sensing resistor +
12	N.C.	Not connected
13	VSET	Reference voltage source set
14	GND	IC ground
15	VREF	Reference voltage source output
16	SET	Output offset current set

**Table 1:** AM462 Pin out

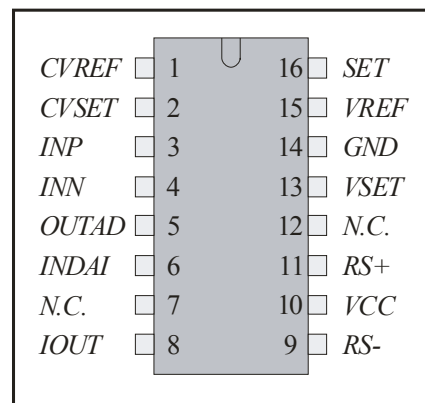
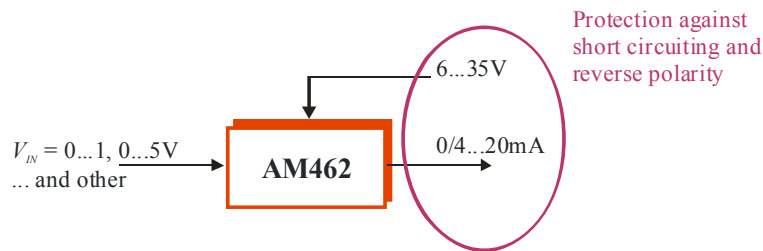

**Figure 11:** AM462 Pin out

# Industrial V/I Converter and Protector IC AM462

## EXAMPLE APPLICATIONS

- *Application as a voltage-to-current converter IC*



**Figure 12:** Application as a current converter IC

- *Converting a 0.5...4.5V sensor (voltage) signal*

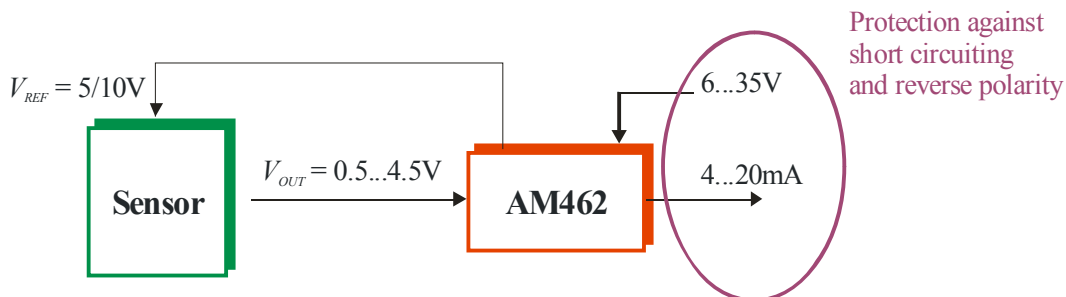

**Figure 13:** Converting a 0.5...4.5V sensor signal

- *Configuration as a peripheral processor IC [2]*

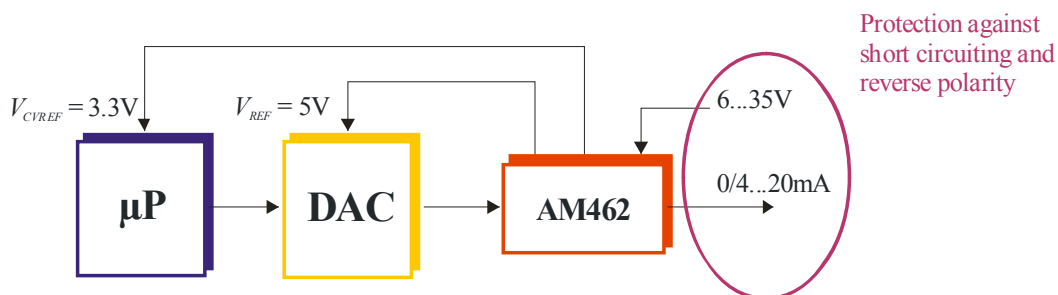

**Figure 14:** Configuration as a peripheral processor IC and supply unit

# Industrial V/I Converter and Protector IC AM462

- *Application as an analog output IC and supply unit for sensors*

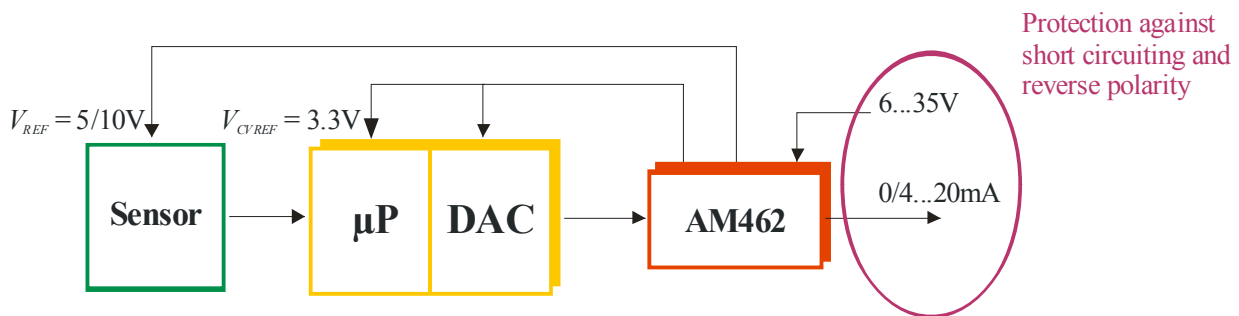

**Figure 15:** Output IC and supply unit in sensor applications

- *Application as a front-end and back-end IC for microprocessors*

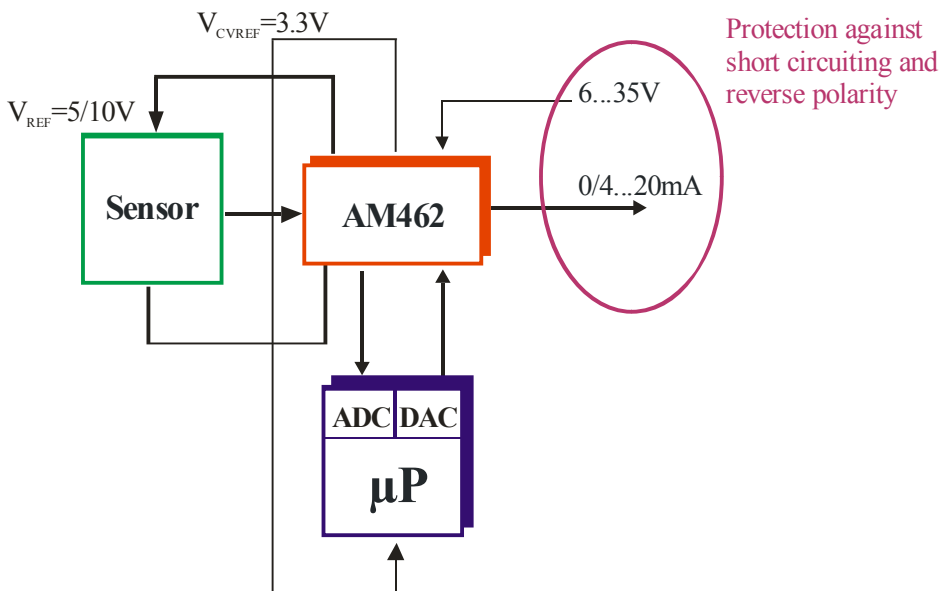

**Figure 16:** Application as an analog front end and back end for microprocessors  
(Frame ASIC concept)

# Industrial V/I Converter and Protector IC AM462

## DELIVERY

The AM462 V/I converter and protector IC is available as the following packages:

- SSOP16
- SO16(n)
- Dice on 5" blue foil (on request)

## PACKAGE DIMENSIONS

Please see our website (data sheets: package.pdf).

## FURTHER READING

[www.analogmicro.de](http://www.analogmicro.de)

- [1] The Frame ASIC concept: See:
- [2] The AM462 can be used as an integrated solution to interface a microprocessor to the industrial 4...20mA network. See: Technical Articles: PR1011 and Interfacing the  $\mu$ Processor with the 4...20mA current loop signal (PLC). See: Application notes AN1014.

## NOTES

Analog Microelectronics reserves the right to make amendments to any dimensions, technical data or other information contained herein without further notice.

***analog microelectronics***

Analog Microelectronics GmbH  
An der Fahrt 13, D – 55124 Mainz  
Internet: <http://www.analogmicro.de>

Phone: +49 (0)6131/91 073 - 0  
Fax: +49 (0)6131/91 073 – 30  
Email: [info@analogmicro.de](mailto:info@analogmicro.de)

December2006  
20/20  
Rev. 2.4