



## Integrated Digital Audio Interface Receiver and Transmitter

### FEATURES

- Digital Audio Interface Transmitter (DIT)
  - Supports Sampling Rates Up to 216kHz
  - Includes Differential Line Driver and CMOS Buffered Outputs
  - Block-Sized Data Buffers for Both Channel Status and User Data
  - Status Registers and Interrupt Generation for Flag and Error Conditions
- Digital Audio Interface Receiver (DIR)
  - PLL Lock Range Includes Sampling Rates from 20kHz to 216kHz
  - Includes Four Differential Input Line Receivers and an Input Multiplexer
  - Bypass Multiplexer Routes Line Receiver Outputs to Line Driver and Buffer Outputs
  - Block-Sized Data Buffers for Both Channel Status and User Data
  - Automatic Detection of Non-PCM Audio Streams (DTS CD/LD and IEC 61937 formats)
  - Audio CD Q-Channel Sub-Code Decoding and Data Buffer
  - Status Registers and Interrupt Generation for Flag and Error Conditions
  - Low Jitter Recovered Clock Output
- User-Selectable Serial Host Interface: SPI™ or I<sup>2</sup>C™
  - Provides Access to On-Chip Registers and Data Buffers
- Two Audio Serial Ports (Ports A and B)
  - Synchronous Serial Interface to External Signal Processors, Data Converters, and Logic
  - Slave or Master Mode Operation with Sampling Rates up to 216kHz
  - Supports Left-Justified, Right-Justified, and Philips I<sup>2</sup>S™ Data Formats
  - Supports Audio Data Word Lengths Up to 24 Bits
- Four General-Purpose Digital Outputs
  - Multifunction Programmable Via Control Registers
- Extensive Power-Down Support
  - Functional Blocks May Be Disabled Individually When Not In Use
- Operates From +1.8V Core and +3.3V I/O Power Supplies
- Small TQFP-48 Package, Compatible with the SRC4382 and SRC4392

### APPLICATIONS

- DIGITAL AUDIO RECORDERS AND MIXING DESKS
- DIGITAL AUDIO INTERFACES FOR COMPUTERS
- DIGITAL AUDIO ROUTERS AND DISTRIBUTION SYSTEMS
- BROADCAST STUDIO EQUIPMENT
- DVD/CD RECORDERS
- SURROUND SOUND DECODERS AND A/V RECEIVERS
- CAR AUDIO SYSTEMS



Please be aware that an important notice concerning availability, standard warranty, and use in critical applications of Texas Instruments semiconductor products and disclaimers thereto appears at the end of this data sheet.

Dolby is a registered trademark of Dolby Laboratories, Inc.  
I<sup>2</sup>C, I<sup>2</sup>S are trademarks of Koninklijke Philips Electronics N.V.  
SPI is a trademark of Motorola.  
All other trademarks are the property of their respective owners.

## DESCRIPTION

The DIX4192 is a highly-integrated CMOS device designed for use in professional and broadcast digital audio systems. The DIX4192 combines a digital audio interface receiver (DIR) and transmitter (DIT), two audio serial ports, and flexible distribution logic for interconnection of the function block data and clocks.

The DIR and DIT are compatible with the AES3, S/PDIF, IEC 60958, and EIAJ CP-1201 interface standards. The audio serial ports and DIT may be operated at sampling rates up to 216kHz. The DIR lock range includes sampling rates from 20kHz to 216kHz.

The DIX4192 is configured using on-chip control registers and data buffers, which are accessed through either a 4-wire serial peripheral interface (SPI) port, or a 2-wire Philips I<sup>2</sup>C bus interface. Status registers provide access to a variety of flag and error bits, which are derived from the various function blocks. An open-drain interrupt output pin is provided, and is supported by flexible interrupt reporting and mask options via control register settings. A master reset input pin is provided for initialization by a host processor or supervisory functions.

The DIX4192 requires a +1.8V core logic supply, in addition to a +3.3V supply for powering portions of the DIR, DIT, and line driver and receiver functions. A separate logic I/O supply supports operation from +1.65V to +3.6V, providing compatibility with low voltage logic interfaces typically found on digital signal processors and programmable logic devices. The DIX4192 is available in a lead-free, TQFP-48 package, and is pin- and register-compatible with the Texas Instruments SRC4382 and SRC4392 products.



This integrated circuit can be damaged by ESD. Texas Instruments recommends that all integrated circuits be handled with appropriate precautions. Failure to observe proper handling and installation procedures can cause damage.

ESD damage can range from subtle performance degradation to complete device failure. Precision integrated circuits may be more susceptible to damage because very small parametric changes could cause the device not to meet its published specifications.

## ORDERING INFORMATION<sup>(1)</sup>

PRODUCT	PACKAGE	PACKAGE DESIGNATOR	SPECIFIED TEMPERATURE RANGE	PACKAGE MARKING	ORDERING NUMBER	TRANSPORT MEDIA, QUANTITY
DIX4192	TQFP-48	PFB	–40°C to +85°C	DIX4192I	DIX4192IPFBT	Tape and Reel, 250
					DIX4192IPFBR	Tape and Reel, 2000

(1) For the most current package and ordering information see the Package Option Addendum at the end of this document, or see the TI web site at [www.ti.com](http://www.ti.com).

## ABSOLUTE MAXIMUM RATINGS<sup>(1)</sup>

Power supplies	
VDD18	–0.3V to +2.0V
VDD33	–0.3V to +4.0V
VIO	–0.3V to +4.0V
VCC	–0.3V to +4.0V
Digital input voltage: Digital logic	
RXCKI, CPM, $\overline{\text{CS}}$ , CCLK, CDIN, CDOUT, $\overline{\text{INT}}$ , $\overline{\text{RST}}$ , MCLK, BLS, SYNC, BCKA, BCKB, LRCKA, LRCKB, SDINA, SDINB	–0.3V to (VIO + 0.3V)
Line receiver input voltage (per pin)	
RX1+, RX1–, RX2+, RX2–, RX3+, RX3–, RX4+, RX4–	(VDD33 + 0.3) V <sub>PP</sub>
Input current (all pins except power and ground)	±10mA
Ambient operating temperature	–40°C to +85°C
Storage temperature	–65°C to +150°C

(1) These limits are stress ratings only. Stresses beyond these limits may result in permanent damage. Extended exposure to absolute maximum ratings may degrade device reliability. Normal operation or performance at or beyond these limits is not specified or ensured.

**ELECTRICAL CHARACTERISTICS: General, DIR, and DIT**

 All specifications are at  $T_A = +25^\circ\text{C}$ ,  $V_{DD18} = +1.8\text{V}$ ,  $V_{DD33} = +3.3\text{V}$ ,  $V_{IO} = +3.3\text{V}$ , and  $V_{CC} = +3.3\text{V}$ , unless otherwise noted.

PARAMETER	CONDITIONS	DIX4192			UNITS
		MIN	TYP	MAX	
<b>DIGITAL I/O CHARACTERISTICS (All I/O pins except line receivers and line driver)</b>					
High-level input voltage, $V_{IH}$		$0.7 \times V_{IO}$		$V_{IO}$	V
Low-level input voltage, $V_{IL}$		0		$0.3 \times V_{IO}$	V
High-level input current, $I_{IH}$			0.5	10	$\mu\text{A}$
Low-level input current, $I_{IL}$			0.5	10	$\mu\text{A}$
High-level output voltage, $V_{OH}$	$I_O = -4\text{mA}$	$0.8 \times V_{IO}$		$V_{IO}$	V
Low-level output voltage, $V_{OL}$	$I_O = +4\text{mA}$	0		$0.2 \times V_{IO}$	V
Input capacitance, $C_{IN}$			3		pF
<b>LINE RECEIVER INPUTS (RX1+, RX1-, RX2+, RX2-, RX3+, RX3-, RX4+, RX4-)</b>					
Differential input sensitivity, $V_{TH}$	Voltage across a given differential input pair		150	200	mV
Input hysteresis, $V_{HY}$		150			mV
<b>LINE DRIVER OUTPUTS (TX+, TX-)</b>					
Differential output voltage, $V_{TXO}$	$R_L = 110\Omega$ Across TX+ and TX-	5.4			$V_{PP}$
<b>MASTER CLOCK INPUT</b>					
Master clock input (MCLK) frequency, $f_{MCLK}$		1		27.7	MHz
Master clock input (MCLK) duty cycle, $f_{MCLKD}$		45		55	%
<b>DIGITAL AUDIO INTERFACE RECEIVER (DIR)</b>					
PLL lock range		20		216	kHz
Reference clock input (RXCKI) frequency, $f_{RXCKI}$		3.5		27.7	MHz
Reference clock input (RXCKI) duty cycle, $f_{RXCKID}$		45		55	%
Recovered clock output (RXCKO) frequency, $f_{RXCKO}$		3.5		27.7	MHz
Recovered clock output (RXCKO) duty cycle, $f_{RXCKOD}$		45		55	%
Recovered clock output (RXCKO) intrinsic jitter	Measured cycle-to-cycle		250		ps RMS
<b>DIGITAL AUDIO INTERFACE TRANSMITTER (DIT)</b>					
Intrinsic output jitter	Measured cycle-to-cycle		200		ps RMS

**ELECTRICAL CHARACTERISTICS: Audio Serial Ports**

All specifications are at  $T_A = +25^\circ\text{C}$ ,  $V_{DD18} = +1.8\text{V}$ ,  $V_{DD33} = +3.3\text{V}$ ,  $V_{IO} = +3.3\text{V}$ , and  $V_{CC} = +3.3\text{V}$ , unless otherwise noted.

PARAMETER	CONDITIONS	DIX4192			UNITS
		MIN	TYP	MAX	
<b>AUDIO SERIAL PORTS (Port A and Port B)</b>					
LRCK clock frequency, $f_{LRCK}$		0		216	kHz
LRCK clock duty cycle, $t_{LRCKD}$			50		%
BCK clock frequency, $f_{BCK}$		0		13.824	MHz
BCK high pulse width, $t_{BCKH}$		10			ns
BCK low pulse width, $t_{BCKL}$		10			ns
Audio data Input (SDIN) setup time, $t_{AIS}$		10			ns
Audio data input (SDIN) hold time, $t_{AISH}$		10			ns
Audio data output (SDOUT) delay, $t_{ADD}$				10	ns

**ELECTRICAL CHARACTERISTICS: SPI Interface**

All specifications are at  $T_A = +25^\circ\text{C}$ ,  $V_{DD18} = +1.8\text{V}$ ,  $V_{DD33} = +3.3\text{V}$ ,  $V_{IO} = +3.3\text{V}$ , and  $V_{CC} = +3.3\text{V}$ , unless otherwise noted.

PARAMETER	CONDITIONS	DIX4192			UNITS
		MIN	TYP	MAX	
<b>HOST INTERFACE: SPI Mode</b>					
Serial clock (CCLK) frequency, $f_{CCLK}$		0		40	MHz
$\overline{CS}$ falling to CCLK rising, $t_{CSCR}$		8			ns
CCLK falling to $\overline{CS}$ rising, $t_{CFCS}$		7			ns
CDIN data setup time, $t_{CDS}$		7			ns
CDIN data hold time, $t_{CDH}$		6			ns
CCLK falling to CDOUT data valid, $t_{CFDO}$				3	ns
$\overline{CS}$ rising to CDOUT high-impedance, $t_{CSZ}$				3	ns

**ELECTRICAL CHARACTERISTICS: I<sup>2</sup>C Standard and Fast Modes**

 All specifications are at T<sub>A</sub> = +25°C, VDD18 = +1.8V, VDD33 = +3.3V, VIO = +3.3V, and VCC = +3.3V, unless otherwise noted.

PARAMETER	CONDITIONS	DIX4192			UNITS
		MIN	TYP	MAX	
<b>HOST INTERFACE: I<sup>2</sup>C Standard Mode<sup>(1)</sup></b>					
SCL clock frequency, f <sub>SCL</sub>		0		100	kHz
Hold time repeated START condition, t <sub>HDSTA</sub>		4			μs
Low period of SCL clock, t <sub>LOW</sub>		4.7			μs
High period of SCL clock, t <sub>HIGH</sub>		4			μs
Setup time repeated START condition, t <sub>SUSTA</sub>		4.7			μs
Data hold time, t <sub>HDDAT</sub>		0 <sup>(2)</sup>		3.45 <sup>(3)</sup>	μs
Data setup time, t <sub>SUDAT</sub>		250			ns
Rise time for Both SDA and SDL, t <sub>R</sub>				1000	ns
Fall time for Both SDA and SDL, t <sub>F</sub>				300	ns
Setup time for STOP condition, t <sub>SUSTO</sub>		4			μs
Bus free time between START and STOP, t <sub>BUF</sub>		4.7			μs
Capacitive load for each bus Line, C <sub>B</sub>				400	pF
Noise margin at low level (including hysteresis), V <sub>NL</sub>		0.1 × VIO			V
Noise margin at high level (including hysteresis), V <sub>NH</sub>		0.2 × VIO			V
<b>HOST INTERFACE: I<sup>2</sup>C Fast Mode<sup>(1)</sup></b>					
SCL clock frequency, f <sub>SCL</sub>		0		400	kHz
Hold time repeated START condition, t <sub>HDSTA</sub>		0.6			μs
Low period of SCL clock, t <sub>LOW</sub>		1.3			μs
High period of SCL clock, t <sub>HIGH</sub>		0.6			μs
Setup time repeated START condition, t <sub>SUSTA</sub>		0.6			μs
Data hold time, t <sub>HDDAT</sub>		0 <sup>(2)</sup>		0.9 <sup>(3)</sup>	μs
Data setup time, t <sub>SUDAT</sub>		100 <sup>(4)</sup>			ns
Rise time for both SDA and SDL, t <sub>R</sub>		20 + 0.2C <sub>B</sub> <sup>(5)</sup>		300	ns
Fall time for both SDA and SDL, t <sub>F</sub>		20 + 0.2C <sub>B</sub> <sup>(5)</sup>		300	ns
Setup time for STOP condition, t <sub>SUSTO</sub>		0.6			μs
Bus free time between START and STOP, t <sub>BUF</sub>		1.3			μs
Spike pulse width suppressed by input filter, t <sub>SP</sub>		0		50	ns
Capacitive load for Each bus Line, C <sub>B</sub>				400	pF
Noise margin at low level (including hysteresis), V <sub>NL</sub>		0.1 × VIO			V
Noise margin at high level (including hysteresis), V <sub>NH</sub>		0.2 × VIO			V

- (1) All values referred to the V<sub>IH</sub> minimum and V<sub>IL</sub> maximum levels listed in the Digital I/O Characteristics section of the *Electrical Characteristics: General, DIR, and DIT* table.
- (2) A device must internally provide a hold time of at least 300ns for the SDA signal (referred to the V<sub>IH</sub> minimum input level) to bridge the undefined region of the falling edge of SCL.
- (3) The maximum t<sub>HDDAT</sub> has only to be met if the device does not stretch the Low period (t<sub>LOW</sub>) of the SCL signal.
- (4) A Fast mode I<sup>2</sup>C bus device can be used in a Standard mode I<sup>2</sup>C bus system, but the requirement that t<sub>SUDAT</sub> be 250ns (minimum) must then be met. For the DIX4192, this condition is automatically the case, since the device does not stretch the Low period of the SCL signal.
- (5) C<sub>B</sub> is defined as the total capacitance of one bus line in picofarads (pF). If mixed with High-Speed mode devices, faster fall times are allowed.

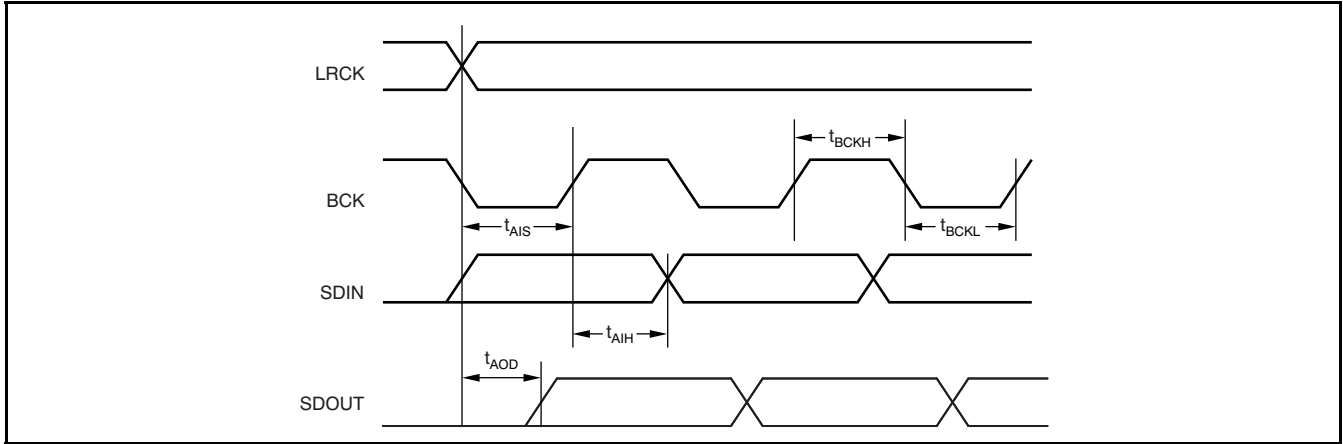
**ELECTRICAL CHARACTERISTICS: Power Supplies**

All specifications are at  $T_A = +25^\circ\text{C}$ ,  $V_{DD18} = +1.8\text{V}$ ,  $V_{DD33} = +3.3\text{V}$ ,  $V_{IO} = +3.3\text{V}$ , and  $V_{CC} = +3.3\text{V}$ , unless otherwise noted.

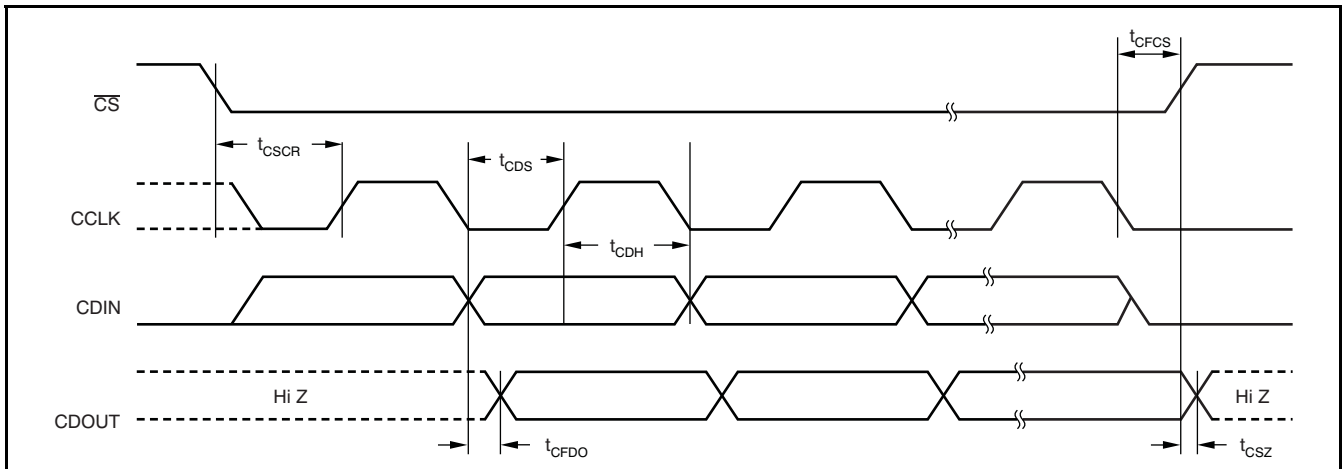
PARAMETER	CONDITIONS	DIX4192			UNITS
		MIN	TYP	MAX	
<b>POWER SUPPLIES</b>					
Recommended supply voltage range					
VDD18		+1.65	+1.8	+1.95	V
VDD33		+3.0	+3.3	+3.6	V
VIO		+1.65	+3.3	+3.6	V
VCC		+3.0	+3.3	+3.6	V
Supply current: initial startup					
All blocks powered down by default					
IDD18S	VDD18 = +1.8V		10		$\mu\text{A}$
IDD33S	VDD33 = +3.3V		10		$\mu\text{A}$
IIOS	VIO = +3.3V		300		$\mu\text{A}$
ICCS	VCC = +3.3V		10		$\mu\text{A}$
Supply current: quiescent					
All blocks powered up with no clocks applied					
IDD18Q	VDD18 = +1.8V		2.3		mA
IDD33Q	VDD33 = +3.3V		0.6		mA
IIOQ	VIO = +3.3V		0.3		mA
ICCQ	VCC = +3.3V		6.3		mA
Supply current: dynamic					
All blocks powered up, $f_S = 48\text{kHz}$					
IDD18D	VDD18 = +1.8V		5.1		mA
IDD33D	VDD33 = +3.3V		14.1		mA
IIOD <sup>(1)</sup>	VIO = +3.3V		46		mA
ICCD	VCC = +3.3V		7.4		mA
Supply current: high sampling rate					
All blocks powered up, $f_S = 192\text{kHz}$					
IDD18H	VDD18 = +1.8V		6.7		mA
IDD33H	VDD33 = +3.3V		15		mA
IIOH <sup>(1)</sup>	VIO = +3.3V		47		mA
ICCH	VCC = +3.3V		7.5		mA
Total power dissipation: initial startup					
All blocks powered down by default					
Total power dissipation: quiescent					
All blocks powered up with no clocks applied					
Total power dissipation: dynamic					
All blocks powered up, $f_S = 48\text{kHz}$					
Total power dissipation: high sampling Rate					
All blocks powered up, $f_S = 192\text{kHz}$					

(1) The typical VIO supply current is measured using the DIX4192EVM evaluation module with loading from the DAIMB mother-board circuitry. VIO supply current is dependent upon the loading on the logic output pins.

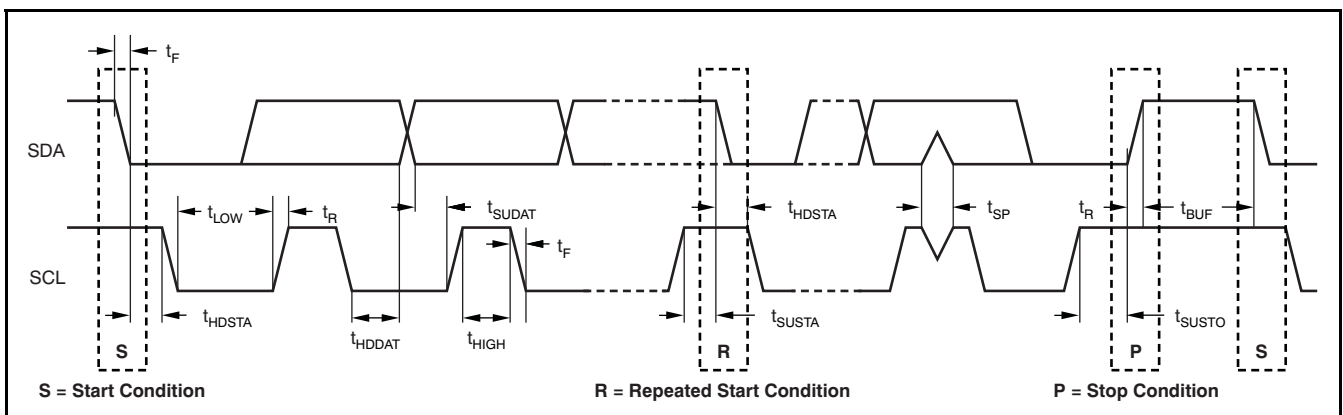
**TIMING DIAGRAMS**



**Figure 1. Audio Serial Port Timing**

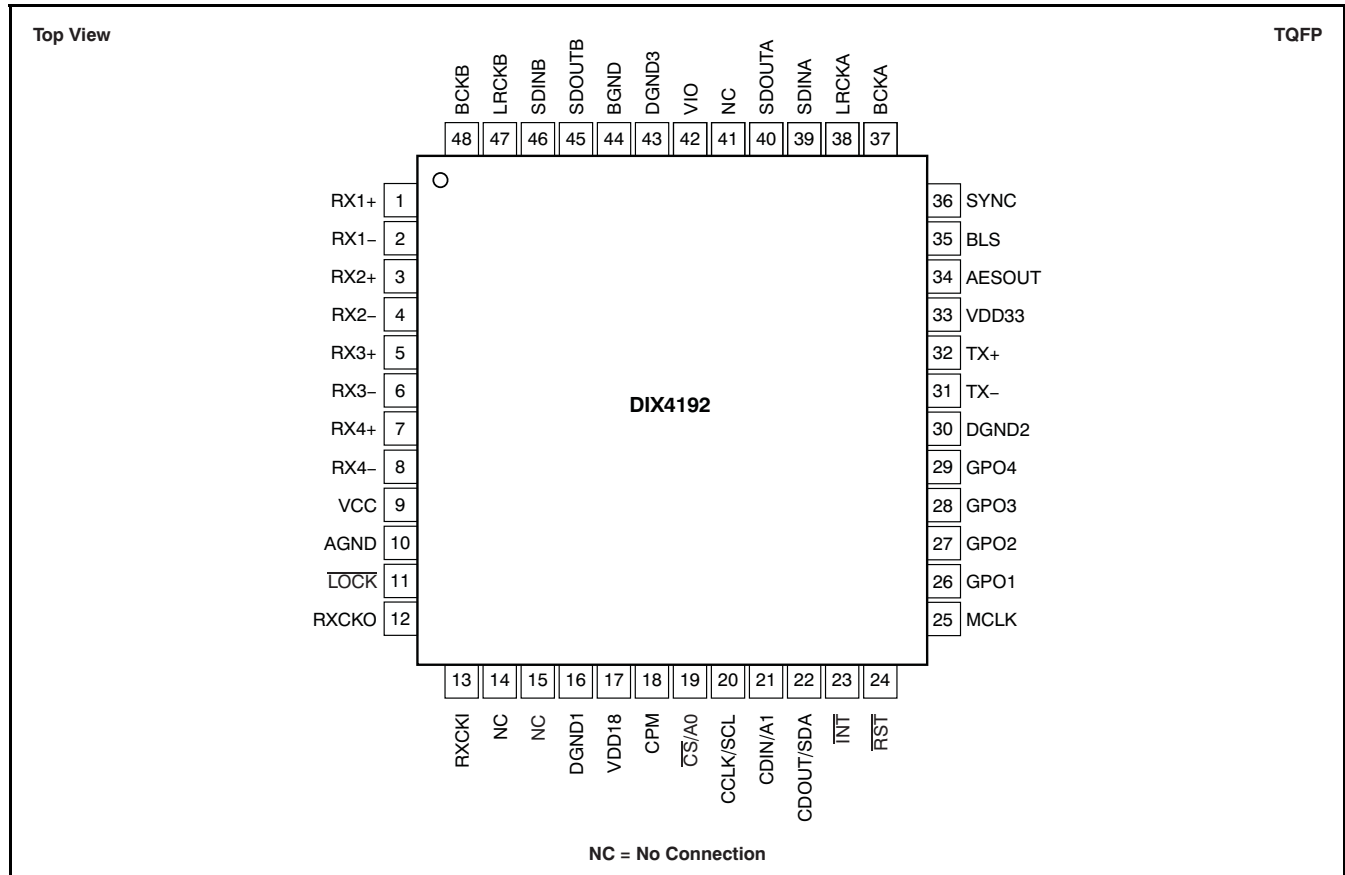


**Figure 2. SPI Interface Timing**



**Figure 3. I<sup>2</sup>C Standard and Fast Mode Timing**

**PIN CONFIGURATION**



**PIN DESCRIPTIONS**

NAME	PIN NUMBER	I/O	DESCRIPTION
RX1+	1	Input	Line receiver 1, noninverting input
RX1-	2	Input	Line receiver 1, inverting input
RX2+	3	Input	Line receiver 2, noninverting input
RX2-	4	Input	Line receiver 2, inverting input
RX3+	5	Input	Line receiver 3, noninverting input
RX3-	6	Input	Line receiver 3, inverting input
RX4+	7	Input	Line receiver 4, noninverting input
RX4-	8	Input	Line receiver 4, inverting input
VCC	9	Power	DIR comparator and PLL power supply, +3.3V nominal
AGND	10	Ground	DIR comparator and PLL power-supply ground
LOCK	11	Output	DIR PLL lock flag (active low)
RXCKO	12	Output	DIR recovered master clock (tri-state output)
RXCKI	13	Input	DIR reference clock
NC	14, 15, 41	—	No internal signal connection, internally bonded to ESD pad
DGND1	16	Ground	Digital core ground
VDD18	17	Power	Digital core supply, +1.8V nominal
CPM	18	Input	Control port mode, 0 = SPI mode, 1 = I <sup>2</sup> C mode
$\overline{CS}$ or A0	19	Input	Chip select (active low) for SPI mode or programmable slave address for I <sup>2</sup> C mode
CCLK or SCL	20	Input	Serial data clock for SPI mode or I <sup>2</sup> C mode
CDIN or A1	21	Input	SPI port serial data input or programmable slave address for I <sup>2</sup> C mode
CDOU or SDA	22	I/O	SPI port serial data output (tri-state output) or serial data I/O for I <sup>2</sup> C mode



**PIN DESCRIPTIONS (continued)**

NAME	PIN NUMBER	I/O	DESCRIPTION
INT	23	Output	Interrupt flag (open-drain, active low)
RST	24	Input	Reset (active low)
MCLK	25	Input	Master clock
GPO1	26	Output	General-purpose output 1
GPO2	27	Output	General-purpose output 2
GPO3	28	Output	General-purpose output 3
GPO4	29	Output	General-purpose output 4
DGND2	30	Ground	DIR line receiver bias and DIT line driver digital ground
TX-	31	Output	DIT line driver inverting output
TX+	32	Output	DIT line driver noninverting output
VDD33	33	Power	DIR line receiver bias and DIT line driver supply, +3.3V nominal
AESOUT	34	Output	DIT buffered AES3-encoded data
BLS	35	I/O	DIT block start clock
SYNC	36	Output	DIT internal sync clock
BCKA	37	I/O	Audio serial Port A bit clock
LRCKA	38	I/O	Audio serial Port A Left/Right clock
SDINA	39	Input	Audio serial Port A data input
SDOUTA	40	Output	Audio serial Port A data output
VIO	42	Power	Logic I/O supply, +1.65V to +3.6V
DGND3	43	Ground	Logic I/O ground
BGND	44	Ground	Substrate ground, connect to AGND (pin 10)
SDOUTB	45	Output	Audio serial Port B data output
SDINB	46	Input	Audio serial Port B data input
LRCKB	47	I/O	Audio serial Port B left/right clock
BCKB	48	I/O	Audio serial Port B bit clock

## PRODUCT OVERVIEW

The DIX4192 is an integrated digital audio interface receiver and transmitter (DIR and DIT). Two audio serial ports, Port A and Port B, support input and output interfacing to external data converters, signal processors, and logic devices. On-chip routing logic provides for flexible interconnection between the four functional blocks. The audio serial ports and DIT may be operated at sampling rates up to 216kHz. The DIR is specified for a PLL lock range that includes sampling rates from 20kHz to 216kHz. All function blocks support audio data word lengths up to 24 bits.

The DIX4192 requires an external host processor or logic for configuration control. The DIX4192 includes a user-selectable serial host interface, which operates as either a 4-wire serial peripheral interface (SPI) port or a 2-wire Philips I<sup>2</sup>C bus interface. The SPI port operates at bit rates up to 40MHz. The I<sup>2</sup>C bus interface may be operated in standard or fast modes, supporting operation at 100kbps and 400kbps, respectively. The SPI and I<sup>2</sup>C interfaces provide access to internal control and status registers, as well as the buffers utilized for the DIR and DIT channel status and user data.

The digital interface receiver (DIR) includes four differential input line receiver circuits, suitable for balanced or unbalanced cable interfaces. Interfacing to optical receiver modules and CMOS logic devices is also supported. The outputs of the line receivers are connected to a 1-of-4 data selector, referred to as the receiver input multiplexer, which is utilized to select one of the four line receiver outputs for processing by the DIR core. The outputs of the line receivers are also connected to a second data selector, the bypass multiplexer, which may be used to route input data streams to the DIT CMOS output buffer and differential line driver functions. This configuration provides a bypass signal path for AES3-encoded input data streams.

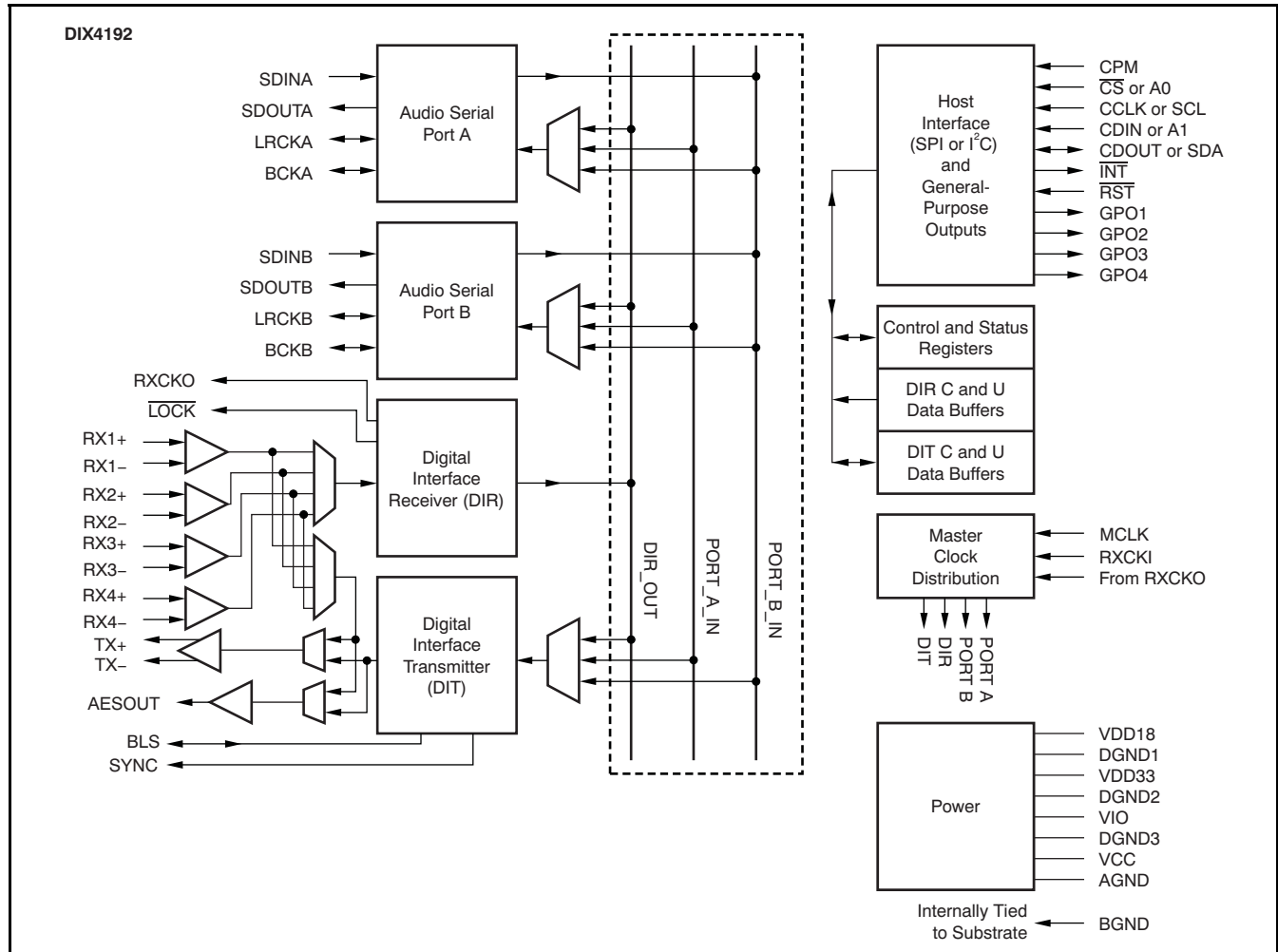
The DIR core decodes the selected input stream data and separates the audio, channel status, user, validity, and parity data. Channel status and user data is stored in block-sized buffers, which may be accessed via the SPI or I<sup>2</sup>C serial host interface, or routed directly to the general-purpose output pins (GPO1 through GPO4). The validity and parity bits are processed to determine error status. The DIR core recovers a low jitter master clock, which may be utilized to generate word and bit clocks using on-chip or external logic circuitry.

The digital interface transmitter (DIT) encodes digital audio input data into an AES3-formatted output data stream. Two DIT outputs are provided, including a differential line driver and a CMOS output buffer. Both the line driver and buffer include 1-of-2 input data selectors, which are utilized to choose either the output of the DIT AES3 encoder, or the output of the bypass multiplexer. The line driver output is suitable for balanced or unbalanced cable interfaces, while the CMOS output buffer supports interfacing to optical transmitter modules and external logic or line drivers. The DIT includes block-sized data buffers for both channel status and user data. These buffers are accessed via either the SPI or I<sup>2</sup>C host interface, or may be loaded directly from the DIR channel status and user data buffers.

The DIX4192 includes four general-purpose digital outputs, or GPO pins. The GPO pins may be configured as simple logic outputs, which may be programmed to either a low or high state. Alternatively, the GPO pins may be connected to one of 13 internal logic nodes, allowing them to serve as functional, status, or interrupt outputs. The GPO pins provide added utility in applications where hardware access to selected internal logic signals may be necessary.

**PRODUCT OVERVIEW (continued)**

Figure 4 shows a simplified functional block diagram for the DIX4192. Additional details for each function block will be covered in respective sections of this datasheet.



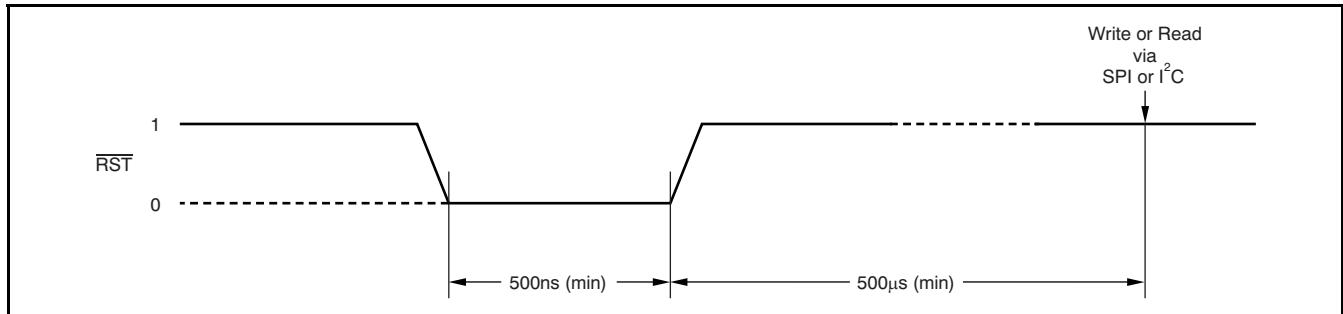
**Figure 4. Functional Block Diagram**

**RESET OPERATION**

The DIX4192 includes an asynchronous active low reset input,  $\overline{RST}$  (pin 24), which may be used to initialize the internal logic at any time. The reset sequence forces all registers and buffers to their default settings. The reset low pulse width must be a minimum of 500ns in length. The user should not attempt a write or read operation using either the SPI or I<sup>2</sup>C port for at least 500µs after the rising edge of  $\overline{RST}$ . See Figure 5 for the reset timing sequence of the DIX4192.

In addition to reset input, the RESET bit in control register 0x01 may be used to force an internal reset, whereby all registers and buffers are forced to their default settings. Refer to the [Control Registers](#) section for details regarding the RESET bit function.

Upon reset initialization, all functional blocks of the DIX4192 default to the power-down state, with the exception of the SPI or I<sup>2</sup>C host interface and the corresponding control registers. The user may then program the DIX4192 to the desired configuration, and release the desired function blocks from the power-down state utilizing the corresponding bits in control register 0x01.

**PRODUCT OVERVIEW (continued)****Figure 5. Reset Sequence Timing****MASTER AND REFERENCE CLOCKS**

The DIX4192 includes two clock inputs, MCLK (pin 25) and RXCKI (pin 13). The MCLK clock input is typically used as the master clock source for the audio serial ports and/or the DIT. The MCLK may also be utilized as the reference clock for the DIR. The RXCKI clock input is typically used for the DIR reference clock source, although it may also be used as the master or reference clock source for the audio serial ports.

In addition to the MCLK and RXCKI clock sources, the DIR core recovers a master clock from the AES3-encoded input data stream. This clock is suitable for use as a master or system clock source in many applications. The recovered master clock output, RXCKO (pin 12), may be utilized as the master or reference clock source for the audio serial ports and/or the DIT, as well as external audio devices.

The master clock frequency for the audio serial ports (Port A and Port B) depends on the Slave or Master mode configuration of the port. In Slave mode, the ports do not require a master clock because the left/right word and bit clocks are inputs, sourced from an external audio device serving as the serial bus timing master. In Master mode, the serial ports derive the left/right word and bit clock outputs from the selected master clock source, MCLK, RXCKI, or RXCKO. The left/right word clock rate is derived from the selected master clock source using one of four clock divider settings (divide by 128, 256, 384, or 512). Refer to the [Audio Serial Port Operation](#) section for additional details.

The DIT always requires a master clock source, which may be either the MCLK input, or the DIR recovered clock output, RXCKO. Like the audio serial ports, the DIT output frame rate is derived from the selected master clock using one of four clock divider settings (divide-by-128, -256, -384, or -512). Refer to the [Digital Interface Transmitter \(DIT\) Operation](#) section for additional details.

The DIR reference clock may be any frequency that meets the PLL1 setup requirements, described in the [Control Registers](#) section. Typically, a common audio system clock rate, such as 11.2896MHz, 12.288MHz, 22.5792MHz, or 24.576MHz, may be used for this clock.

It is recommended that the clock sources for MCLK and RXCKI input be generated by low-jitter crystal oscillators for optimal performance. In general, phase-locked loop (PLL) clock synthesizers should be avoided, unless they are designed and/or specified for low clock jitter.

**PRODUCT OVERVIEW (continued)**

**AUDIO SERIAL PORT OPERATION**

The DIX4192 includes two audio serial ports, Port A and Port B. Both ports are 4-wire synchronous serial interfaces, supporting simultaneous input and output operation. Since each port has only one pair of left/right word and bit clocks, the input and output sampling rates are identical. A simplified block diagram is shown in [Figure 6](#).

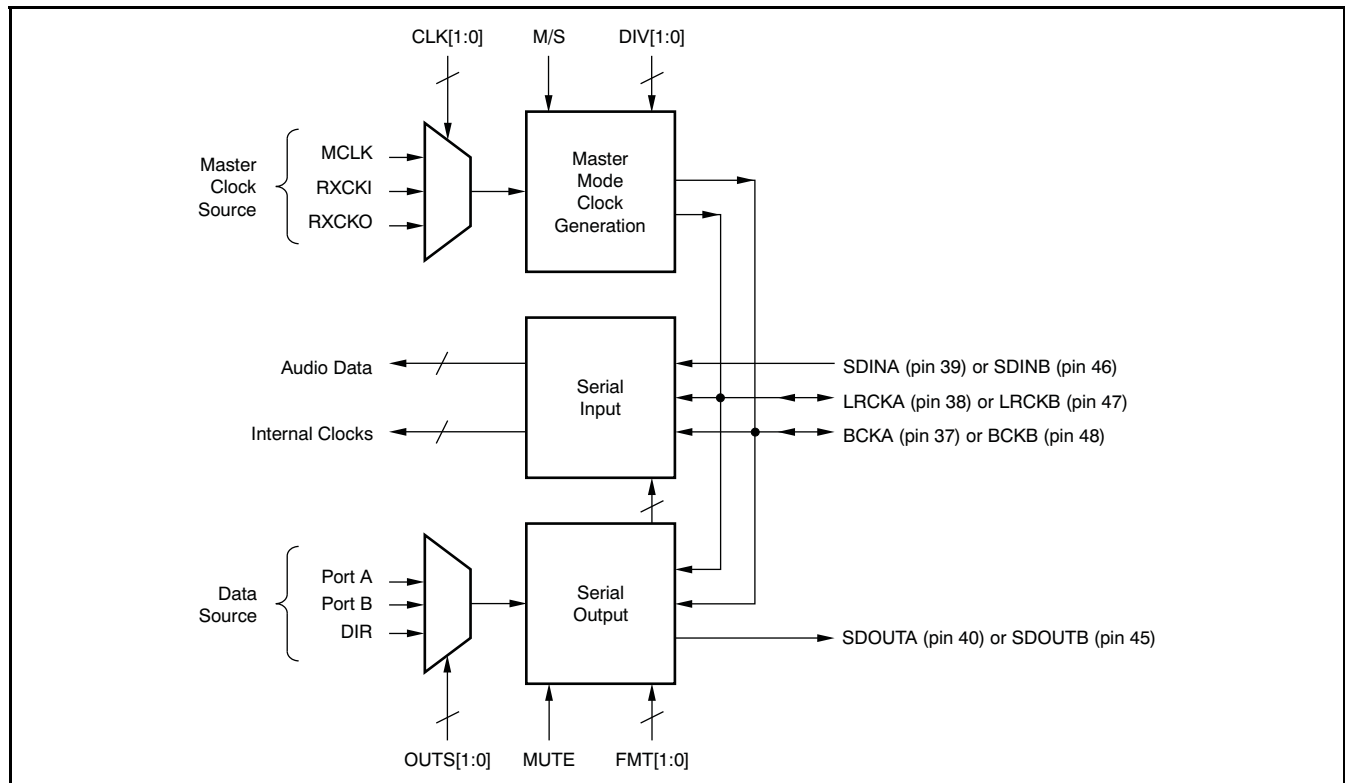
The audio serial ports may be operated at sampling rates up to 216kHz, and support audio data word lengths up to 24 bits. Philips I<sup>2</sup>S, Left-Justified, and Right-Justified serial data formats are supported. Refer to [Figure 7](#).

The left/right word clock (LRCKA or LRCKB) and the bit clock (BCKA or BCKB) may be configured for either Master or Slave mode operation. In Master mode these clocks are outputs, derived from the selected master clock source using internal clock dividers. The master clock source may be 128, 256, 384, or 512 times the audio input/output sampling rate, with the clock divider being selected using control register bits for each port. In Slave mode the left/right word and bit clocks are inputs, and are sourced from an external audio device acting as the serial bus master.

The LRCKA or LRCKB clocks operate at the input/output sampling rate,  $f_s$ . The BCKA and BCKB clock rates are fixed at 64 times the left/right word clock rate in Master mode. For Slave mode, the minimum BCKA and BCKB clock rate is determined by the audio data word length multiplied by two, since there are two audio data channels per left/right word clock period. For example, if the audio data word length is 24 bits, the bit clock rate must be at least 48 times the left/right word clock rate, allowing one bit clock period for each data bit in the serial bit stream.

Serial audio data is clocked into the port on the rising edge of the bit clock, while data is clocked out of the port on the falling edge of the bit clock. Refer to the [Electrical Characteristics: Audio Serial Ports](#) table for parametric information and [Figure 1](#) for a timing diagram related to audio serial port operation.

The audio serial ports are configured using control registers 0x03 through 0x06. Refer to the [Control Registers](#) section for descriptions of the control register bits.



**Figure 6. Audio Serial Port Block Diagram**

PRODUCT OVERVIEW (continued)

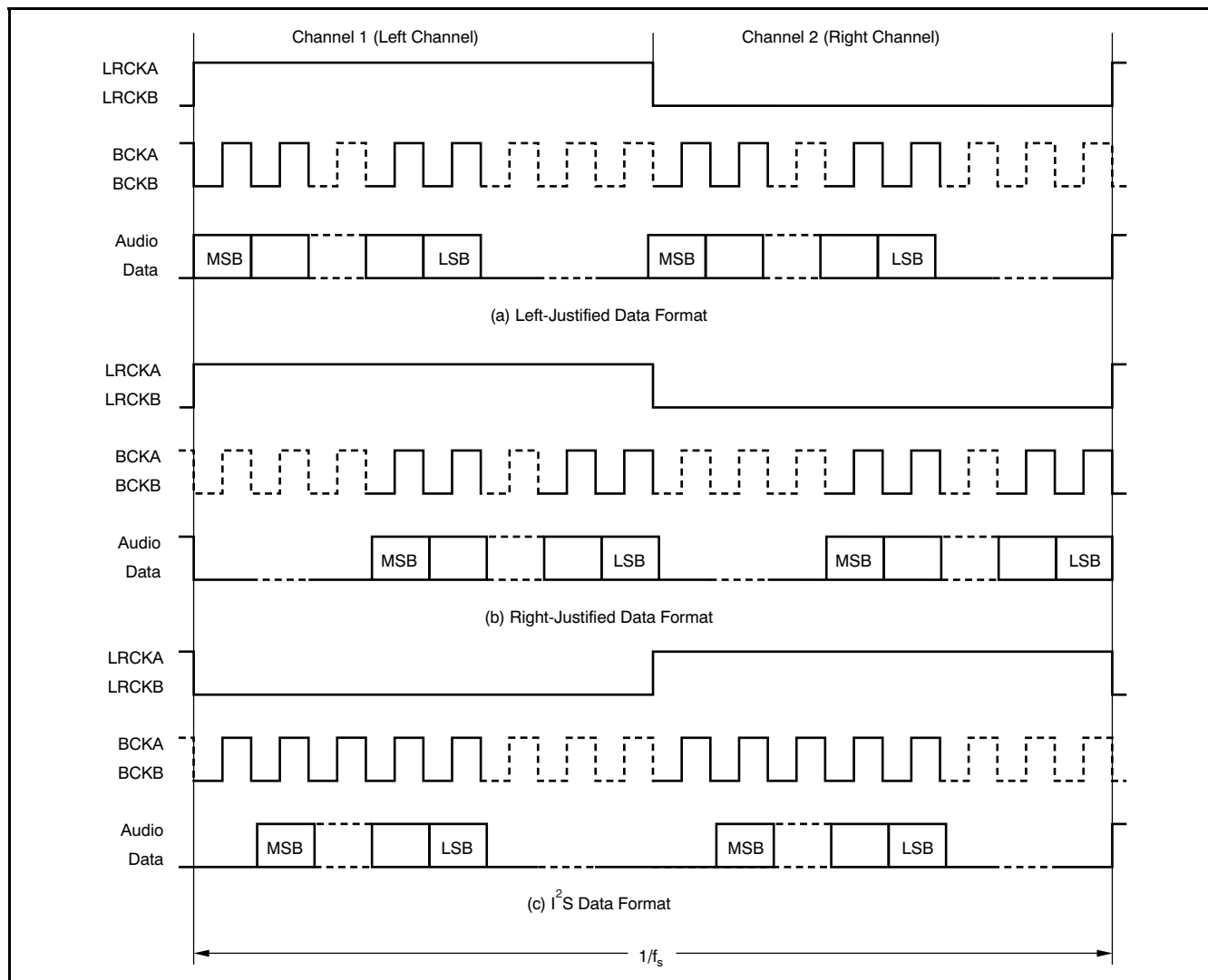


Figure 7. Audio Data Formats

OVERVIEW OF THE AES3 DIGITAL AUDIO INTERFACE PROTOCOL

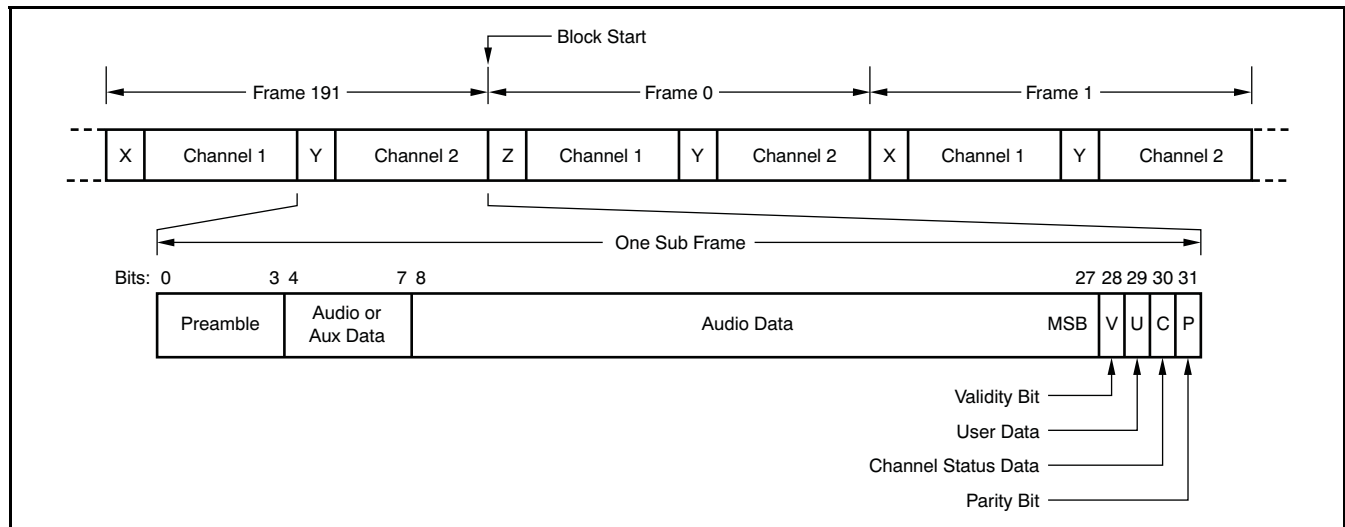
This section introduces the basics of digital audio interface protocols pertaining to the transmitter (DIT) and receiver (DIR) blocks of the DIX4192. Emphasis is placed upon defining the basic terminology and characteristics associated with the AES3-2003 standard protocol, the principles of which may also be applied to a number of consumer-interface variations, including S/PDIF, IEC-60958, and EIAJ CP-1201. It is assumed that the reader is familiar with the AES3 and S/PDIF interface formats. Additional information is available from the sources listed in the [Reference Documents](#) section.

The AES3-2003 standard defines a technique for two-channel linear PCM data transmission over 110Ω shielded twisted-pair cable. The AES-3id document extends the AES3 interface to applications employing 75Ω coaxial cable connections. In addition, consumer transmission variants, such as those defined by the S/PDIF, IEC 60958, and CP-1201 standards, utilize the same encoding techniques but with different physical interfaces or transmission media. Channel status data definitions also vary between professional and consumer interface implementations.

## PRODUCT OVERVIEW (continued)

For AES3 transmission, data is encoded into frames, with each frame containing two subframes of audio and status data, corresponding to audio Channels 1 and 2 (or Left and Right, respectively, for stereophonic audio). [Figure 8](#) shows the AES3 frame and subframe formatting. Each subframe includes four bits for the preamble, up to 24 bits for audio and/or auxiliary data, one bit indicating data validity (V), one bit for channel status data (C), one bit for user data (U), and one bit for setting parity (P).

The 4-bit preamble is used for synchronization and identification of blocks and subframes. The X and Y preamble codes are used to identify the start of the Channel 1 and Channel 2 subframes, as shown in [Figure 8](#). However, the X preamble for the first subframe of every 192 frames is replaced by the Z preamble, which identifies the start of a new block of channel status and user data.



**Figure 8. AES3 Frame and Subframe Encoding**

One block is comprised of 192 frames of data. This format translates to 192 bits each for channel status and user data for each channel. The 192 bits are organized into 24 data bytes, which are defined by the AES3-2003 and consumer standards documents. The AES18 standard defines recommended usage and formatting of the user data bits, while consumer applications may utilize the user data for other purposes. The DIX4192 also includes block-sized transmitter and receiver channel status and user data buffers, which have 24 bytes each for the channel status and user data assigned to audio Channels 1 and 2. Refer to the [Channel Status and User Data Buffer Maps](#) section for the organization of the buffered channel status and user data for the receiver and transmitter functions.

The audio data for Channel 1 and Channel 2 may be up to 24 bits in length, and occupies bits 4 through 27 of the corresponding subframe. Bit 4 is the LSB while bit 27 is the MSB. If only 20 bits are required for audio data, then bits 8 through 27 are utilized for audio data, while bits 4 through 7 are utilized for auxiliary data bits.

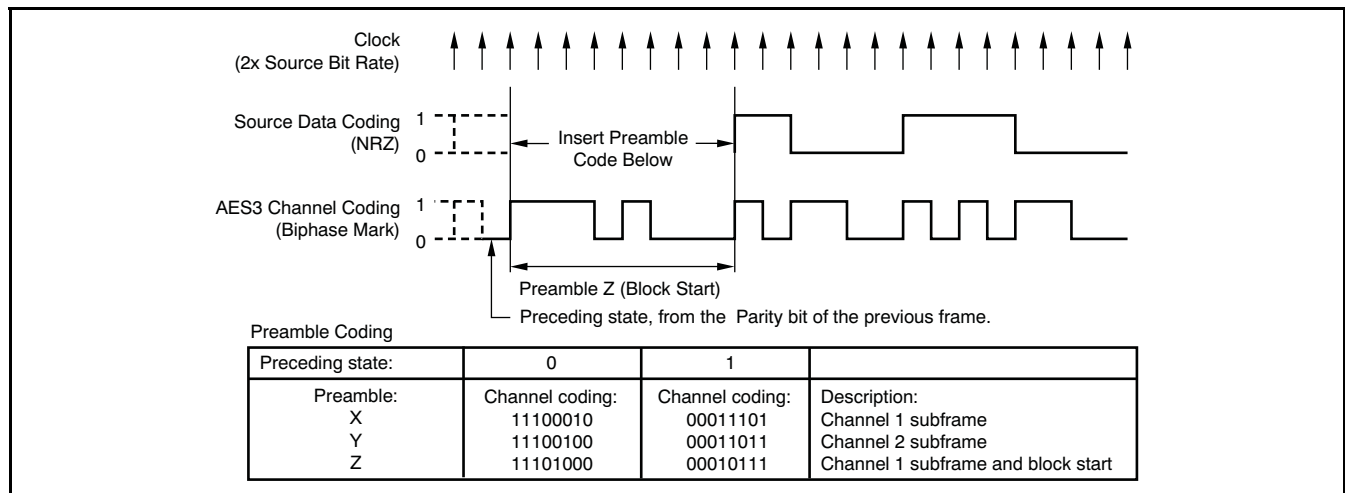
The validity (V) bit indicates whether or not the audio sample word being transmitted is suitable for digital-to-analog (D/A) conversion or further digital processing at the receiver end of the connection. If the validity bit is 0, then the audio sample is suitable for conversion or additional processing. If the validity bit is 1, then the audio sample is not suitable for conversion or additional processing.

The parity (P) bit is set to either a 0 or 1, such that bits 4 through 31 carry an even number of ones and zeros for even parity. The DIT block in the DIX4192 automatically manages the parity bit, setting it to a 0 or 1 as needed. The DIR block checks the parity of bits 4 through 31 and generates a parity error if odd parity is detected.

**PRODUCT OVERVIEW (continued)**

The binary non-return to zero (NRZ) formatted audio and status source data for bits 4 through 31 of each subframe are encoded utilizing a Biphasic Mark format for transmission. This format allows for clock recovery at the receiver end, as well as making the interface insensitive to the polarity of the balanced cable connections. The preambles at the start of each subframe are encoded to intentionally violate the Biphasic Mark formatting, making their detection by the receiver reliable, as well as avoiding the possibility of audio and status data imitating the preambles. [Figure 9](#) shows the Biphasic Mark and preamble encoding.

Although the AES3 standard originally defined transmission for sampling rates up to 48kHz, the interface is capable of handling higher sampling rates, given that attention is paid to cable length and impedance matching. Equalization at the receiver may also be required, depending on the cable and matching factors. It is also possible to transmit and decode more than two channels of audio data utilizing the AES3 or related consumer interfaces. Special encoding and/or compression algorithms are utilized to support multiple channels, including the Dolby® AC-3, DTS, MPEG-1/2, and other data reduced audio formats.



**Figure 9. Biphasic Mark Encoding**

**DIGITAL INTERFACE TRANSMITTER (DIT) OPERATION**

The DIT encodes a given two-channel or data-reduced audio input stream into an AES3-encoded output stream. In addition to the encoding function, the DIT includes differential line driver and CMOS-buffered output functions. The line driver is suitable for driving balanced or unbalanced line interfaces, while the CMOS-buffered output is designed to drive external logic or line drivers, as well as optical transmitter modules. [Figure 10](#) illustrates the functional block diagram for the DIT.

The input of the DIT receives the audio data for Channels 1 and 2 from one of three possible sources: Port A, Port B, or the DIR. By default, Port A is selected as the source. The DIT also requires a master clock source, which may be provided by either the MCLK input (pin 25) or RXCKO (the DIR recovered master clock output). A master clock divider is utilized to select the frame rate for the AES3-encoded output data. The TXDIV[1:0] bits in control register 0x07 are utilized to select divide by 128, 256, 384, or 512 operation.

Channel status and user data for Channels 1 and 2 are input to the AES3 encoder via the corresponding Transmitter Access (TA) data buffers. The TA data buffers are in turn loaded from the User Access (UA) buffers, which are programmed via the SPI or I<sup>2</sup>C host interface, or loaded from the DIR Receiver Access (RA) data buffers. The source of the channel status and user data is selected utilizing the TXCUS[1:0] bits in control register 0x09. When the DIR is selected as the input source, the channel status and user data output from the DIT is delayed by one block in relation to the audio data.

The validity (V) bit may be programmed using one of two sources. The VALSEL bit in control register 0x09 is utilized to select the validity data source for the DIT block. The default source is the VALID bit in control register 0x07, which is written via the SPI or I<sup>2</sup>C host interface. The validity bit may also be transferred from the AES3 decoder output of the DIR, where the V bit for the DIT subframes tracks the decoded DIR value frame by frame.

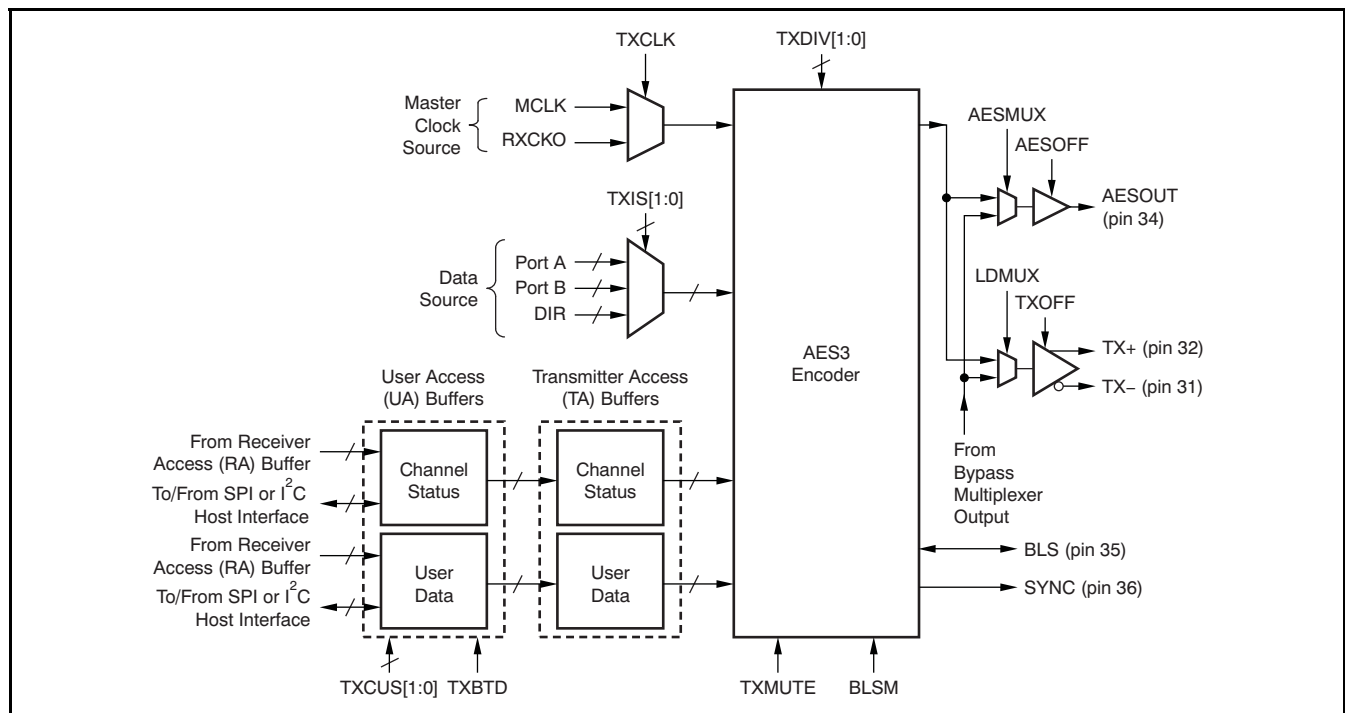


**PRODUCT OVERVIEW (continued)**

The Parity (P) bit will always be generated by the AES3 encoder internal parity generator logic, such that bits 4 through 31 of the AES3-encoded subframe are even parity.

The AES3 encoder output is connected to the output line driver and CMOS buffer source multiplexers. As shown in Figure 10, the source multiplexers allow the line driver or buffer to be driven by the AES3-encoded data from the DIT, or by the bypass multiplexer, which is associated with the outputs of the four differential input line receivers preceding the DIR core. The bypass multiplexer allows for one of the four line receiver outputs to be routed to the line driver or buffer output, thereby providing a bypass mode of operation. Both the line driver and CMOS output buffer include output disables, set by the TXOFF and AESOFF bits in control register 0x08. When the outputs are disabled, they are forced to a low logic state.

The AES3 encoder includes an output mute function that sets all bits for both the Channel 1 and 2 audio and auxiliary data to zero. The preamble, V, U, and C bits are unaffected, while the P bit is recalculated. The mute function is controlled using the TXMUTE bit in control register 0x08.



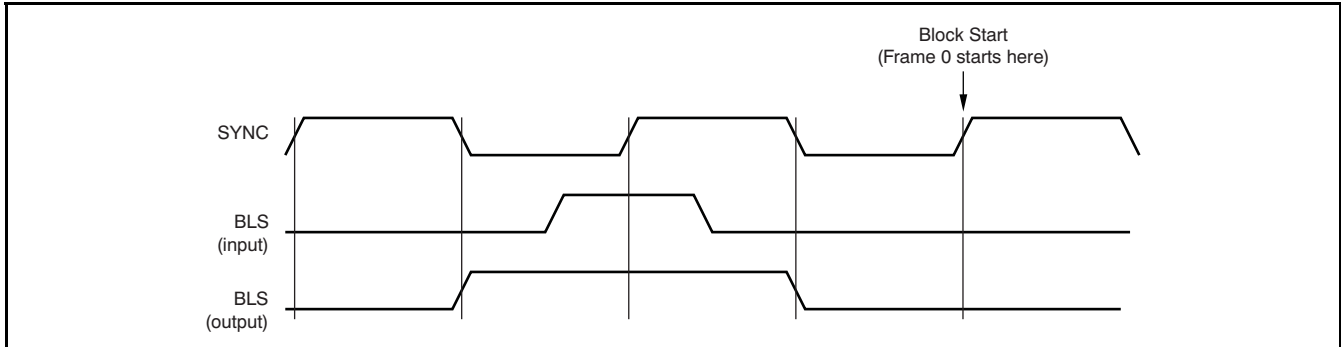
**Figure 10. Digital Interface Transmitter (DIT) Functional Block Diagram**

The AES3 encoder includes a block start input/output pin, BLS (pin 35). The BLS pin may be programmed as an input or output. The input/output state of the BLS pin is programmed using the BLSM bit in control register 0x07. By default, the BLS pin is configured as an input.

As an input, the BLS pin may be utilized to force a block start condition, whereby the start of a new block of channel status and user data is initiated by generating a Z preamble for the next frame of data. The BLS input must be synchronized with the DIT internal SYNC clock. This clock is output on SYNC (pin 36). The SYNC clock rising edge is aligned with the start of each frame for the AES3-encoded data output by the DIT. Figure 11 illustrates the format required for an external block start signal, as well as indicating the format when the BLS pin is configured as an output. When the BLS pin is an output, the DIT generates the block start signal based upon the internal SYNC clock.

For details regarding DIT control and status registers, as well as channel status and user data buffers, refer to the [Control Registers](#) and [Channel Status and User Data Buffer Maps](#) sections.

**PRODUCT OVERVIEW (continued)**

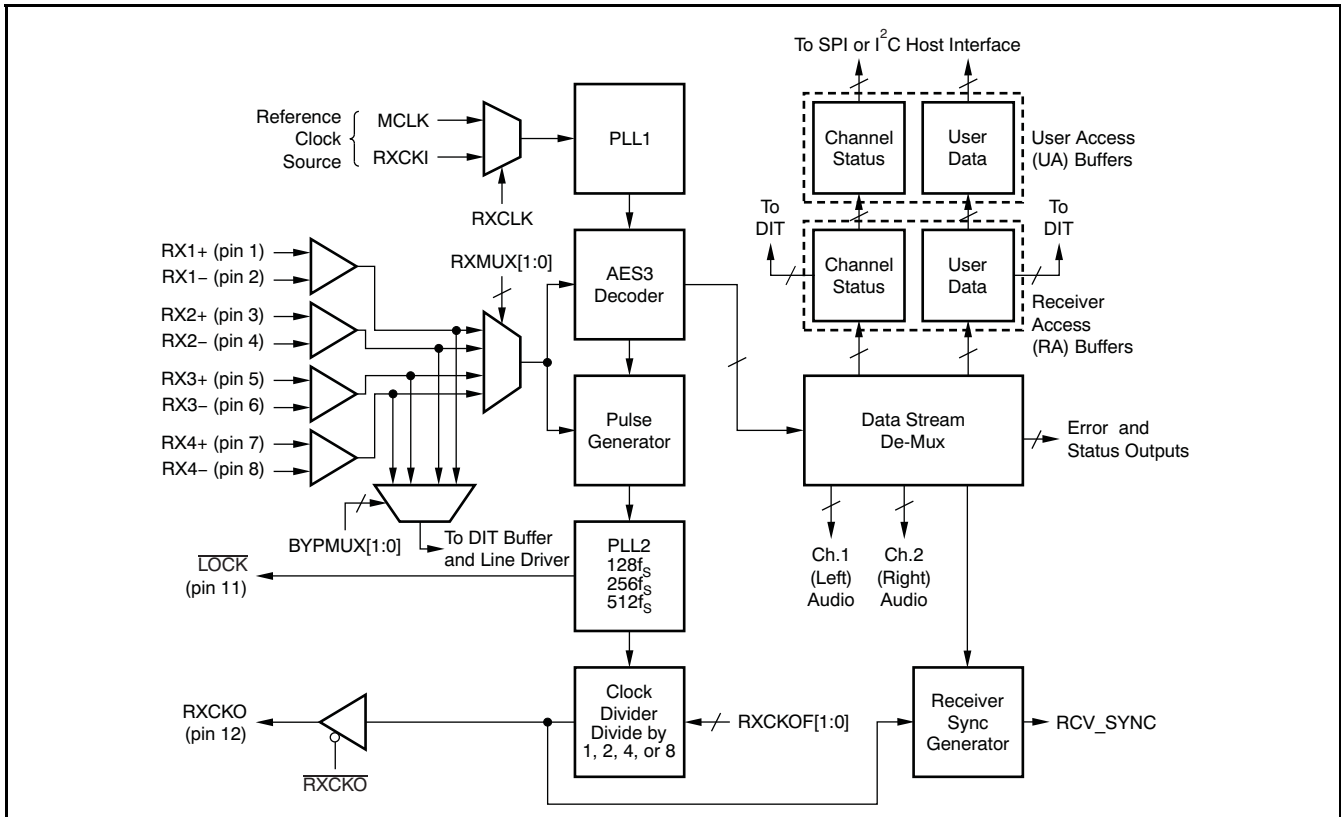


**Figure 11. DIT Block Start Timing**

**DIGITAL INTERFACE RECEIVER (DIR) OPERATION**

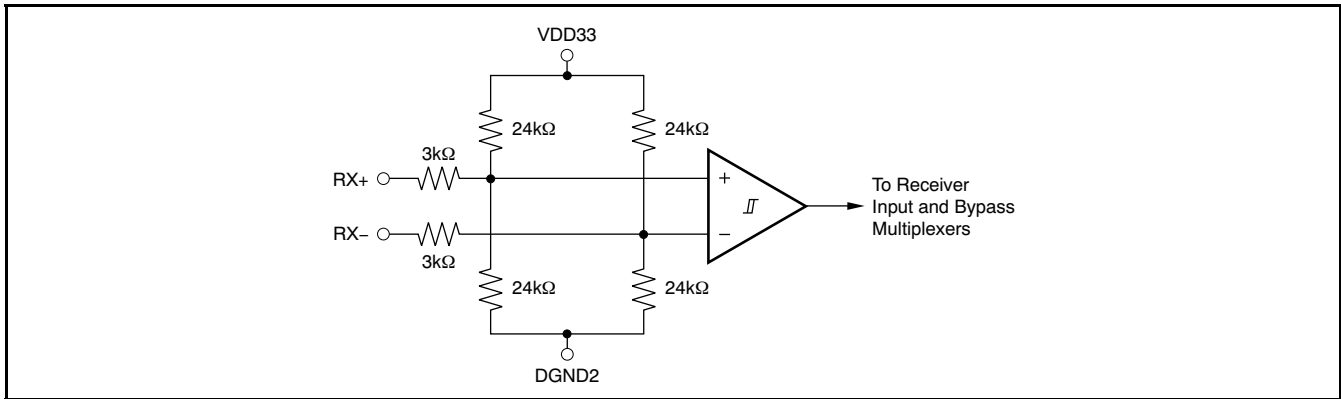
The DIR performs AES3 decoding and clock recovery and provides the differential line receiver functions. The lock range of the DIR includes frame/sampling rates from 20kHz to 216kHz. [Figure 12](#) shows the functional block diagram for the DIR.

Four differential line receivers are utilized for signal conditioning the encoded input data streams. The receivers can be externally configured for either balanced or unbalanced cable interfaces, as well as interfacing with CMOS logic level inputs from optical receivers or external logic circuitry. See [Figure 13](#) for a simplified schematic for the line receiver. External connections are discussed in the [Receiver Input Interfacing](#) section.



**Figure 12. Digital Interface Receiver (DIR) Functional Block Diagram**

**PRODUCT OVERVIEW (continued)**



**Figure 13. Differential Line Receiver Circuit**

The outputs of the four line receivers are connected to two 1-of-4 data selectors: the receiver input multiplexer and the bypass multiplexer. The input multiplexer selects one of the four line receiver outputs as the source for the AES3-encoded data stream to be processed by the DIR core. The bypass multiplexer is utilized to route a line receiver output to either the DIT line driver or CMOS-buffered outputs, thereby bypassing all other internal circuitry. The bypass function is useful for simple signal distribution and routing applications.

The DIR requires a reference clock, supplied by an external source applied at either the RXCKI (pin 13) or MCLK (pin 25) clock inputs. PLL1 multiplies the reference clock to a higher rate, which is utilized as the oversampling clock for the AES3 decoder. The decoder samples the AES3-encoded input stream in order to extract all of the audio and status data. The decoded data stream is sent on to a de-multiplexer, where audio and status data are separated for further processing and buffering. The pulse generator circuitry samples the encoded input data stream and generates a clock that is 16 times the frame/sampling rate (or  $f_S$ ). The  $16f_S$  clock is then processed by PLL2, which further multiplies the clock rate and provides low-pass filtering for jitter attenuation. The available PLL2 output clock rates include  $512f_S$ ,  $256f_S$ , and  $128f_S$ . The maximum available PLL2 output clock rate for a given input sampling rate is estimated by internal logic and made available for readback via status register 0x13.

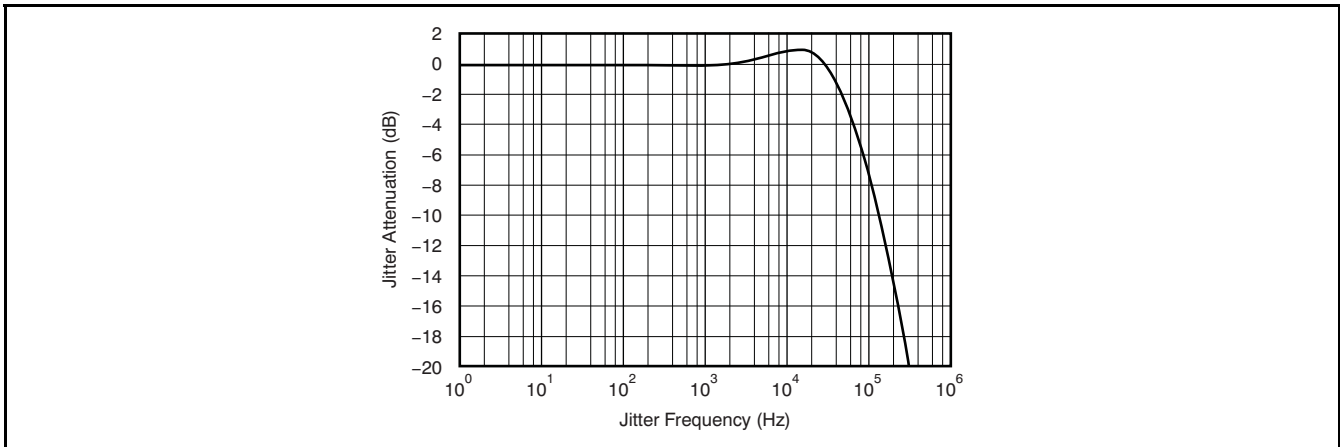
The output of PLL2 may be divided by a factor of two, four, or eight, or simply passed through to the recovered master clock output, RXCKO (pin 12). The RXCKO clock may also be routed internally to other function blocks, where it may be further divided to create left/right word and bit clocks. The RXCKO output may be disabled and forced to a high-impedance state by means of a control register bit, allowing other tri-state buffered clocks to be tied to the same external circuit node, if needed. By default, the RXCKO output (pin 12) is disabled and forced to a high-impedance state.

Figure 14 illustrates the frequency response of PLL2. Jitter attenuation starts at approximately 50kHz. Peaking is nominally 1dB, which is within the 2dB maximum allowed by the AES3 standard. The receiver jitter tolerance plot for the DIR is illustrated in Figure 15, along with the required AES3 jitter tolerance template. The DIR jitter tolerance satisfies the AES3 requirements, as well as the requirements set forth by the IEC60958-3 specification. Figure 15 was captured using a full-scale 24-bit, two-channel, AES3-encoded input stream with a 48kHz frame rate.

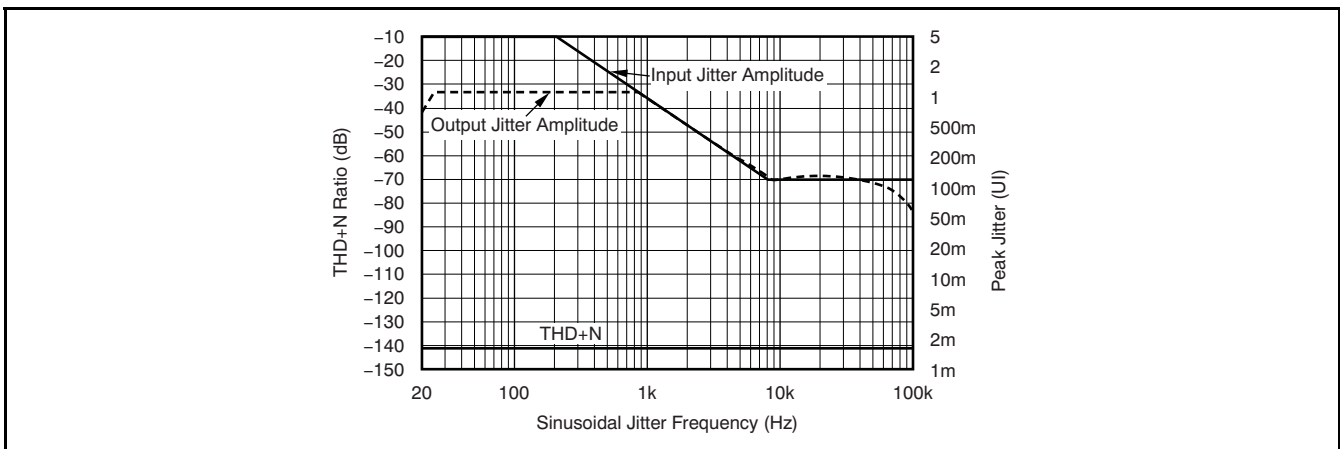
The decoded audio data, along with the internally-generated sync clocks, may be routed to other function blocks, including Port A, Port B, and/or the DIT. The decoded channel status and user data are buffered in the corresponding Receiver Access (RA) data buffers, then transferred to the corresponding User Access (UA) data buffers, where it may be read back through either the SPI or I<sup>2</sup>C serial host interface. The contents of the RA buffers may also be transferred to the DIT UA data buffers; this transfer is illustrated in Figure 10. The channel status and user data bits may also be output serially through the general-purpose output pins, GPO[4:1]. Figure 16 illustrates the output format for the GPO pins when used for this purpose, along with the DIR block start (BLS) and frame synchronization (SYNC) clocks. The rising edges of the DIR SYNC clock output are aligned with the start of each frame for the received AES3 data.

**PRODUCT OVERVIEW (continued)**

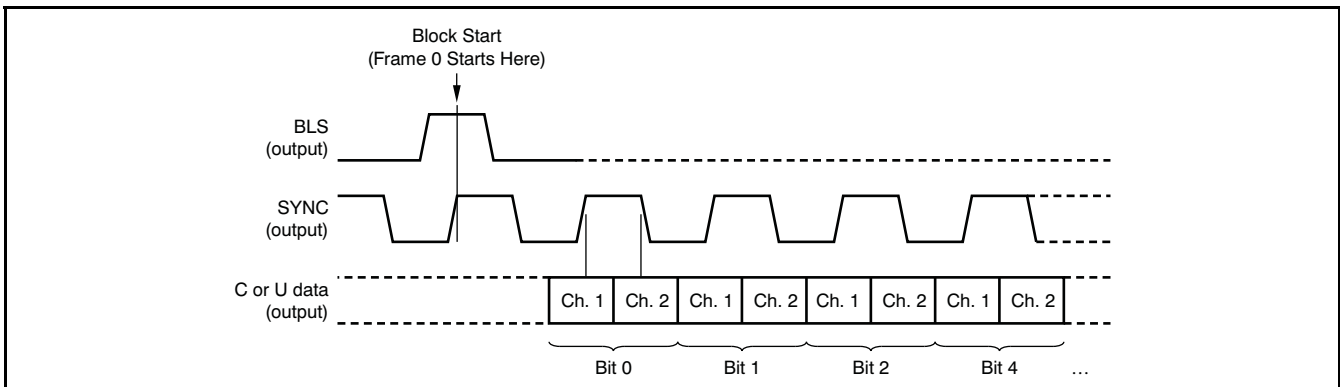
The DIR includes a dedicated, active low AES3 decoder and PLL2 lock output, named  $\overline{\text{LOCK}}$  (pin 11). The lock output is active only when both the AES3 decoder and PLL2 indicate a lock condition. Additional DIR status flags may be output at the general-purpose output (GPO) pins, or accessed through the status registers via the SPI or I<sup>2</sup>C host interface. Refer to the [General-Purpose Digital Outputs](#) and [Control Registers](#) sections for additional information regarding the DIR status functions.



**Figure 14. DIR Jitter Attenuation Characteristics**



**Figure 15. DIR Jitter Tolerance Plot**



**Figure 16. DIR Channel Status and User Data Serial Output Format Via the GPO Pins**

**PRODUCT OVERVIEW (continued)**

**GENERAL-PURPOSE DIGITAL OUTPUTS**

The DIX4192 includes four general-purpose digital outputs, GPO1 through GPO4 (pins 26 through 29, respectively). A GPO pin may be programmed to a static high or low state. Alternatively, a GPO pin may be connected to one of 13 internal logic nodes, allowing the GPO pin to inherit the function of the selected signal. Control registers 0x1B through 0x1E are utilized to select the function of the GPO pins. For details regarding GPO output configuration, refer to the [Control Registers](#) section. [Table 1](#) summarizes the available output options for the GPO pins.

**Table 1. General-Purpose Output Pin Configurations**

GPOn3	GPOn2	GPOn1	GPOn0	GPOn FUNCTION
0	0	0	0	GPOn is forced low (default)
0	0	0	1	GPOn is forced high
0	0	1	0	Reserved
0	0	1	1	DIT interrupt flag; active low
0	1	0	0	DIR interrupt flag; active low
0	1	0	1	DIR 50/15µs emphasis flag; active low
0	1	1	0	DIR non-audio data flag; active high
0	1	1	1	DIR non-valid data flag; active high
1	0	0	0	DIR channel status data serial output
1	0	0	1	DIR user data serial output
1	0	1	0	DIR block start clock output
1	0	1	1	DIR COPY bit output (0 = copyright asserted, 1 = copyright not asserted)
1	1	0	0	DIR L (or origination) bit output (0 = 1st generation or higher, 1 = original)
1	1	0	1	DIR Parity error flag; active high
1	1	1	0	DIR internal sync clock output; may be used as the data clock for the channel status and user data serial outputs.
1	1	1	1	DIT internal sync clock

**HOST INTERFACE OPERATION:  
SERIAL PERIPHERAL INTERFACE (SPI) MODE**

The DIX4192 supports a 4-wire SPI port when the CPM input (pin 18) is forced low or tied to ground. The SPI port supports high-speed serial data transfers up to 40Mbps. Register and data buffer write and read operations are supported.

The  $\overline{CS}$  input (pin 19) serves as the active low chip select for the SPI port. The  $\overline{CS}$  input must be forced low in order to write or read registers and data buffers. When  $\overline{CS}$  is forced high, the data at the CDIN input (pin 21) is ignored, and the CDOUT output (pin 22) is forced to a high-impedance state. The CDIN input serves as the serial data input for the port; the CDOUT output serves as the serial data output.

The CCLK input (pin 20) serves as the serial data clock for both the input and output data. Data is latched at the CDIN input on the rising edge of CCLK, while data is clocked out of the CDOUT output on the falling edge of CCLK.

[Figure 17](#) illustrates the SPI port protocol. Byte 0 is referred to as the command byte, where the most significant bit (or MSB) is the read/write bit. For the R/W bit, a 0 indicates a write operation, while a 1 indicates a read operation. The remaining seven bits of the command byte are utilized for the register address targeted by the write or read operation. Byte 1 is a *don't care* byte, and may be set to all zeroes. This byte is included in order to retain protocol compatibility with earlier Texas Instruments digital audio interface and sample rate converter products, including the [DIT4096](#), [DIT4192](#), the [SRC418x](#) series devices, and the [SRC419x](#) series devices.

The SPI port supports write and read operations for multiple sequential register addresses through the implementation of an auto-increment mode. As shown in Figure 17, the auto-increment mode is invoked by simply holding the  $\overline{CS}$  input low for multiple data bytes. The register address is automatically incremented after each data byte transferred, starting with the address specified by the command byte.

Refer to the [Electrical Characteristics: SPI Interface](#) table and Figure 2 for specifications and a timing diagram that highlight the key parameters for SPI interface operation.

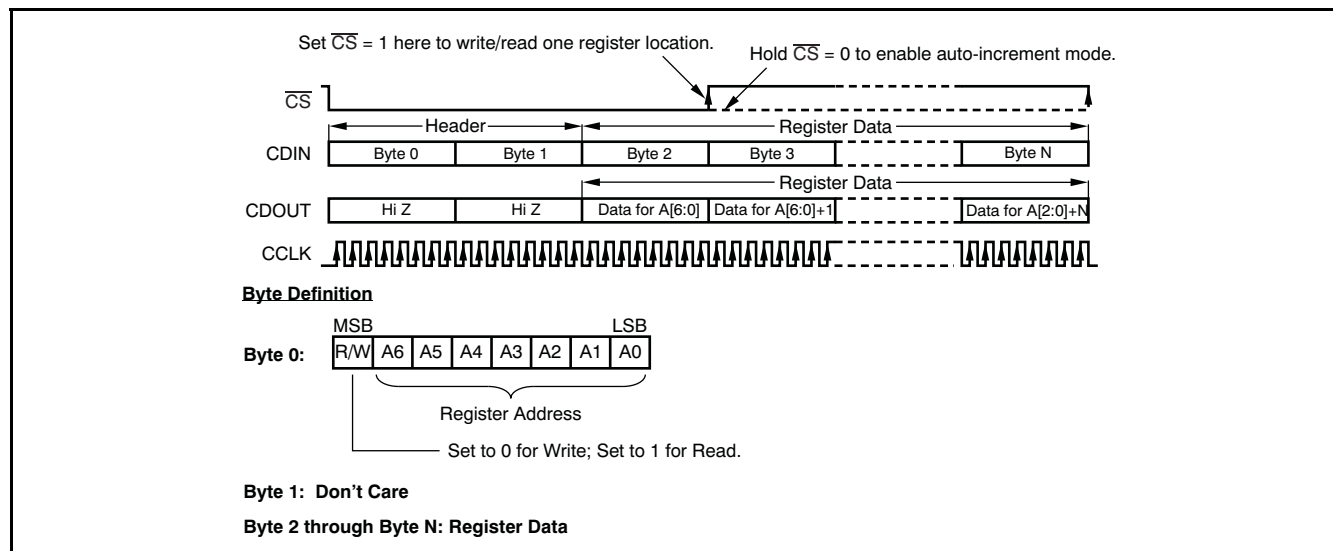


Figure 17. Serial Peripheral Interface (SPI) Protocol for the DIX4192

## HOST INTERFACE OPERATION: PHILIPS I<sup>2</sup>C MODE

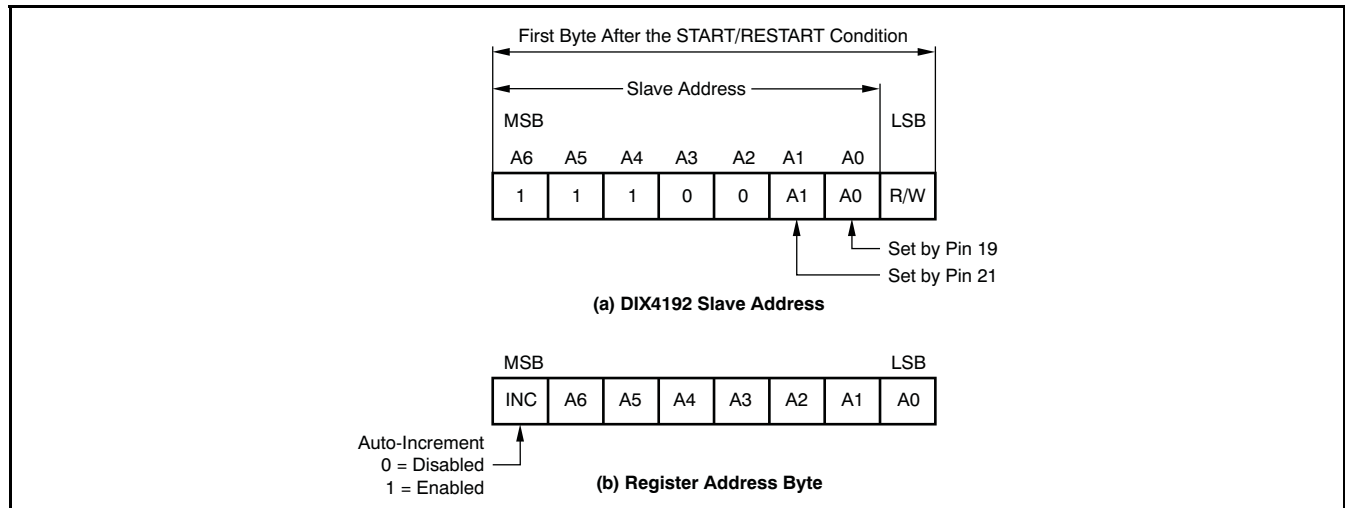
The DIX4192 supports a 2-wire Philips I<sup>2</sup>C bus interface when CPM (pin 18) is forced high or pulled up to the VIO supply rail. The DIX4192 functions as a Slave-only device on the bus. Standard and Fast modes of operation are supported. Standard mode supports data rates up to 100kbps, while Fast mode supports data rates up to 400kbps. Fast mode is downward compatible with Standard mode, and these modes are sometimes referred to as Fast/Standard, or F/S mode. The I<sup>2</sup>C Bus Specification (Version 2.1, January 2000), available from Philips Semiconductor, provides the details for the bus protocol and implementation. It is assumed that the reader is familiar with this specification. Refer to the [Electrical Characteristics: I<sup>2</sup>C Standard and Fast Modes](#) table and Figure 3 for specifications and a timing diagram that highlight the key parameters for I<sup>2</sup>C interface operation.

When the I<sup>2</sup>C mode is invoked, pin 20 becomes SCL (which serves as the bus clock) and pin 22 becomes SDA (which carries the bi-directional serial data for the bus). Pins 19 and 21 become A0 and A1, respectively, and function as the hardware configurable portion of the 7-bit slave address.

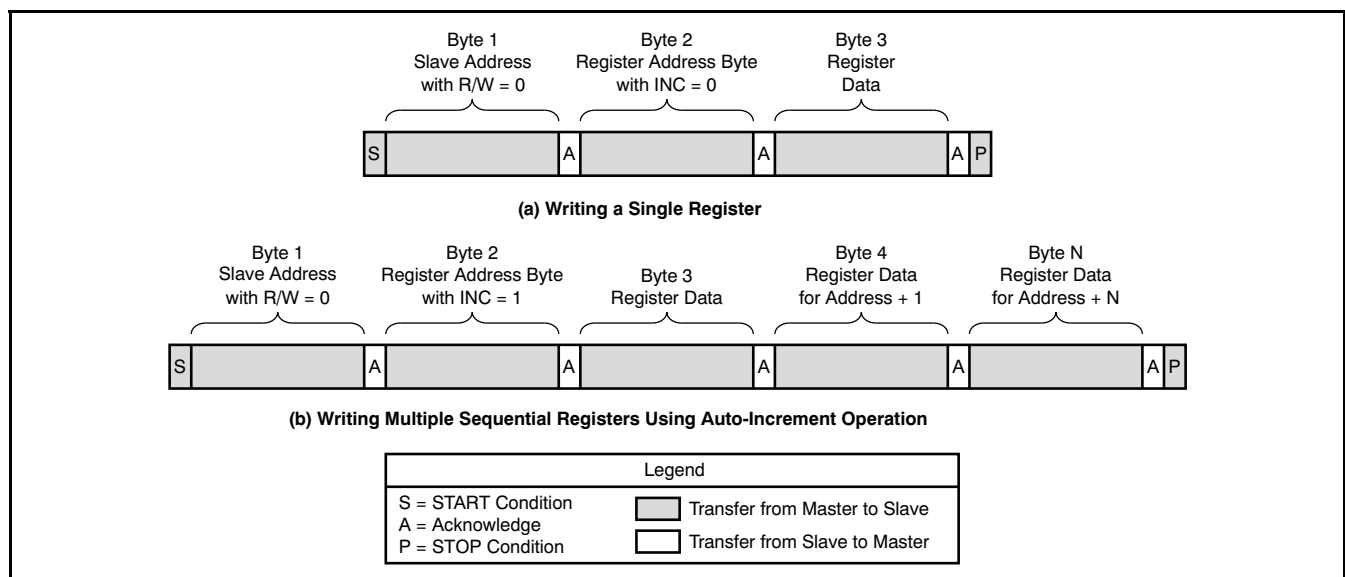
The DIX4192 utilizes a 7-bit Slave address; see Figure 18(a). Bits A2 through A6 are fixed and bits A0 and A1 are hardware programmable using pins 19 and 21, respectively. The programmable bits allow for up to four DIX4192 devices to be connected to the same bus. The slave address is followed by the Register Address Byte, which points to a specific register or data buffer location in the DIX4192 register map. The register address byte is comprised of seven bits for the address, and one bit for enabling or disabling auto-increment operation; see Figure 18(b). Auto-increment mode allows multiple sequential register locations to be written to or read back in a single operation, and is especially useful for block write and read operations.

Figure 19 illustrates the protocol for Standard and Fast mode Write operations. When writing a single register address, or multiple non-sequential register addresses, the single register write operation of Figure 19(a) may be used one or more times. When writing multiple sequential register addresses, the auto-increment mode of Figure 19(b) improves efficiency. The register address is automatically incremented by one for each successive byte of data transferred.

Figure 20 illustrates the protocol for Standard and Fast mode Read operations. The current address read operation of Figure 20(a) assumes the value of the register address from the previously executed write or read operation, and is useful for polling a register address for status changes. Figure 20(b) and Figure 20(c) illustrate read operations for one or more random register addresses, with or without auto-increment mode enabled.



**Figure 18. DIX4192 Slave Address and Register Address Byte Definitions**



**Figure 19. Fast/Standard Mode Write Operations**

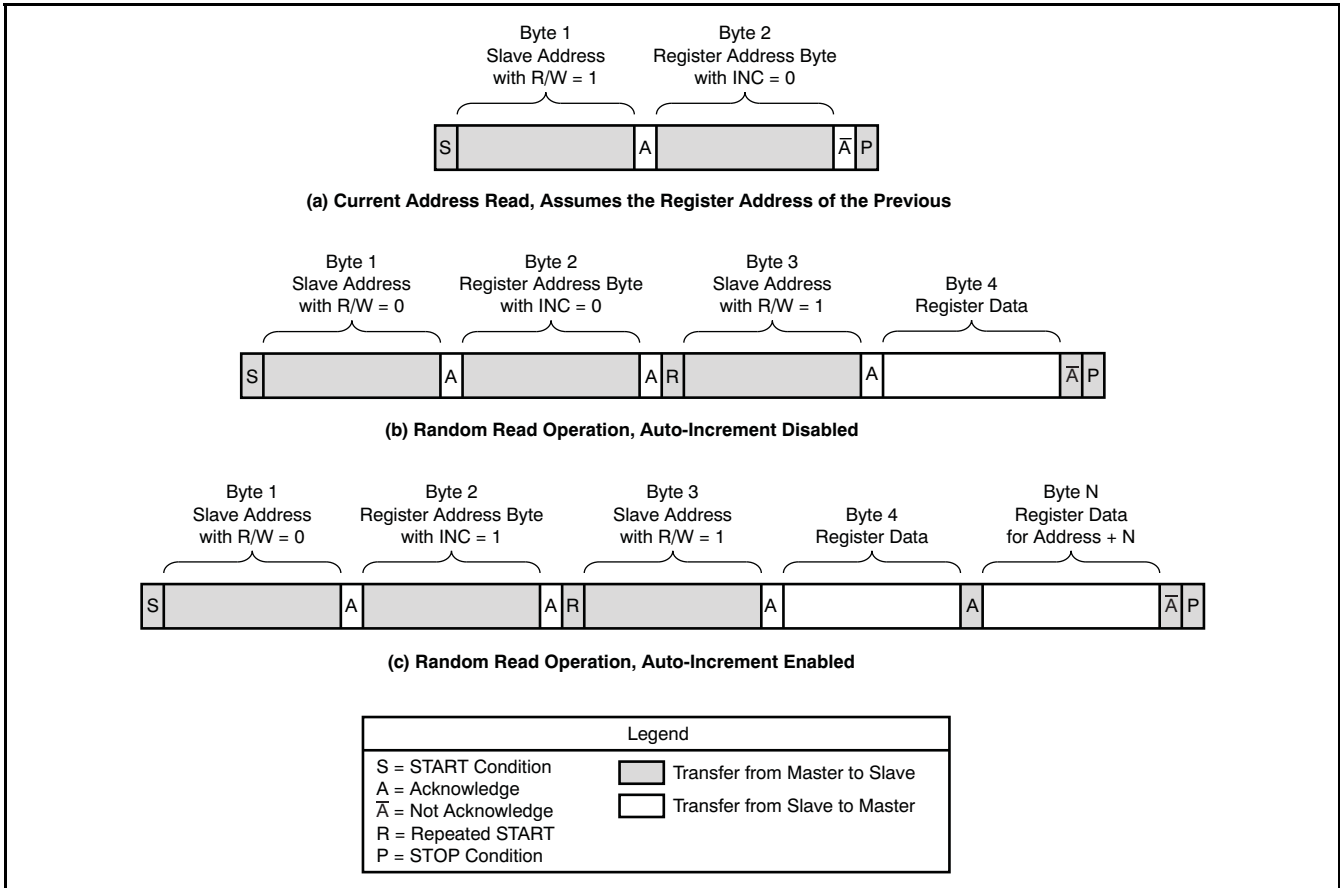


Figure 20. Fast/Standard Mode Read Operations

### INTERRUPT OUTPUT

The DIX4192 includes multiple internal status bits, many of which may be set to trigger an interrupt signal. The interrupt signal is output at INT (pin 23), which is an active low, open-drain output. The INT pin requires a pull-up resistor to the VIO supply rail. The value of the pull-up is not critical, but a 10kΩ device should be sufficient for most applications. Figure 21 shows the interrupt output pin connection. The open-drain output allows interrupt pins from multiple DIX4192 devices to be connected in a wired OR configuration.

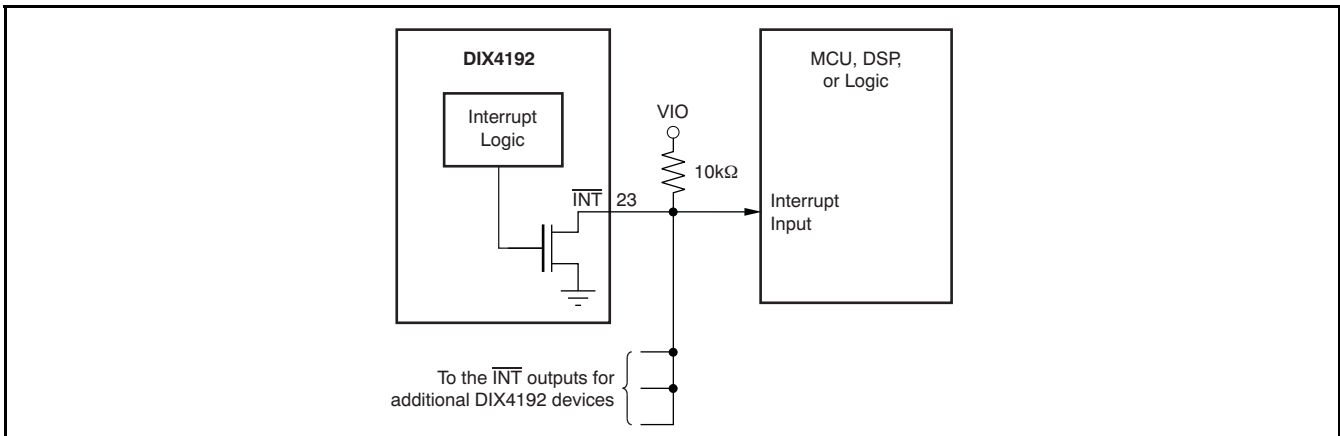


Figure 21. Interrupt Output Pin Connections



## APPLICATIONS INFORMATION

Typical application diagrams and power-supply connections are presented in this section to aid the customer in hardware designs employing the DIX4192 device.

[Figure 22](#) illustrates typical application connections for the DIX4192 using an SPI host interface. The SPI host will typically be a microcontroller, digital signal processor, or a programmable logic device. In addition to providing the SPI bus master, the host may be utilized to process interrupt and flag outputs from the DIX4192. The audio serial ports are connected to external digital audio devices, which may include data converters, digital signal processors, digital audio interface receivers/transmitters, or other logic devices. The DIR inputs and DIT outputs are connected to line, optical, or logic interfaces (see the [Receiver Input Interfacing](#) and [Transmitter Output Interfacing](#) sections). Master and DIR reference clock sources are also shown.

[Figure 23](#) illustrates typical application connections for the DIX4192 using an I<sup>2</sup>C bus interface. The I<sup>2</sup>C bus master will typically be a microcontroller, digital signal processor, or a programmable logic device. In addition to providing the I<sup>2</sup>C bus master, the host may be used to process interrupt and flag outputs from the DIX4192. Pull-up resistors are connected from SCL (pin 20) and SDA (pin 22) to the VIO supply rail. These resistors are required for the open drain outputs of the I<sup>2</sup>C interface. All other connections to the DIX4192 are the same as the SPI host case discussed previously.

[Figure 24](#) illustrates the recommended power-supply connections and bypassing for the DIX4192. In this case, it is assumed that the VIO, VDD33, and VCC supplies are powered from the same +3.3V power source. The VDD18 core supply is powered from a separate supply, or derived from the +3.3V supply using a linear voltage regulator, as illustrated with the optional regulator circuitry of [Figure 24](#).

The 0.1μF bypass capacitors are surface-mount X7R ceramic, and should be located as close to the device as possible. These capacitors should be connected directly between the supply and corresponding ground pins of the DIX4192. The ground pin is then connected directly to the ground plane of the printed circuit board (PCB). The larger value capacitors, shown connected in parallel to the 0.1μF capacitors, are recommended. At a minimum, there should at least be footprints on the PCB for installation of these larger capacitors, so that experiments can be run with and without the capacitors installed, in order to determine the effect on the measured performance of the DIX4192. The larger value capacitors can be surface-mount X7R multilayer ceramic or tantalum chip.

The substrate ground, BGND (pin 44), should be connected by a PCB trace to AGND (pin 10). The AGND pin is then connected directly to the ground plane. This connection helps to reduce noise in the DIR section of the device, aiding the overall jitter and noise tolerance for the receiver.

A series resistor is shown between the +3.3V supply and VCC (pin 9) connection. This resistor combines with the bypass capacitors to create a simple RC filter to remove higher frequency components from the VCC supply. The series resistor should be a metal film type for best filtering characteristics. As a substitute for the resistor, a ferrite bead can be utilized, although it may have to be physically large in order to contribute to the filtering.

APPLICATIONS INFORMATION (continued)

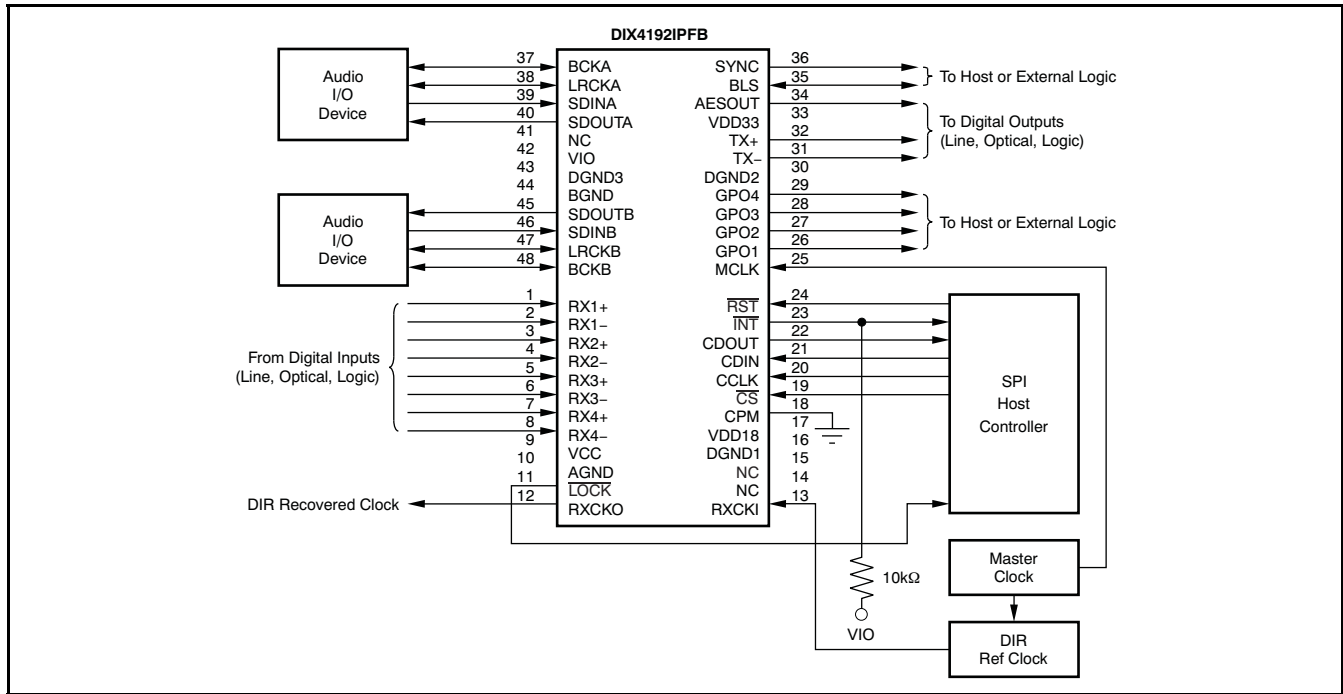


Figure 22. Typical Application Diagram Using SPI Host Interface  
(See Figure 24 for Power-Supply Connections.)

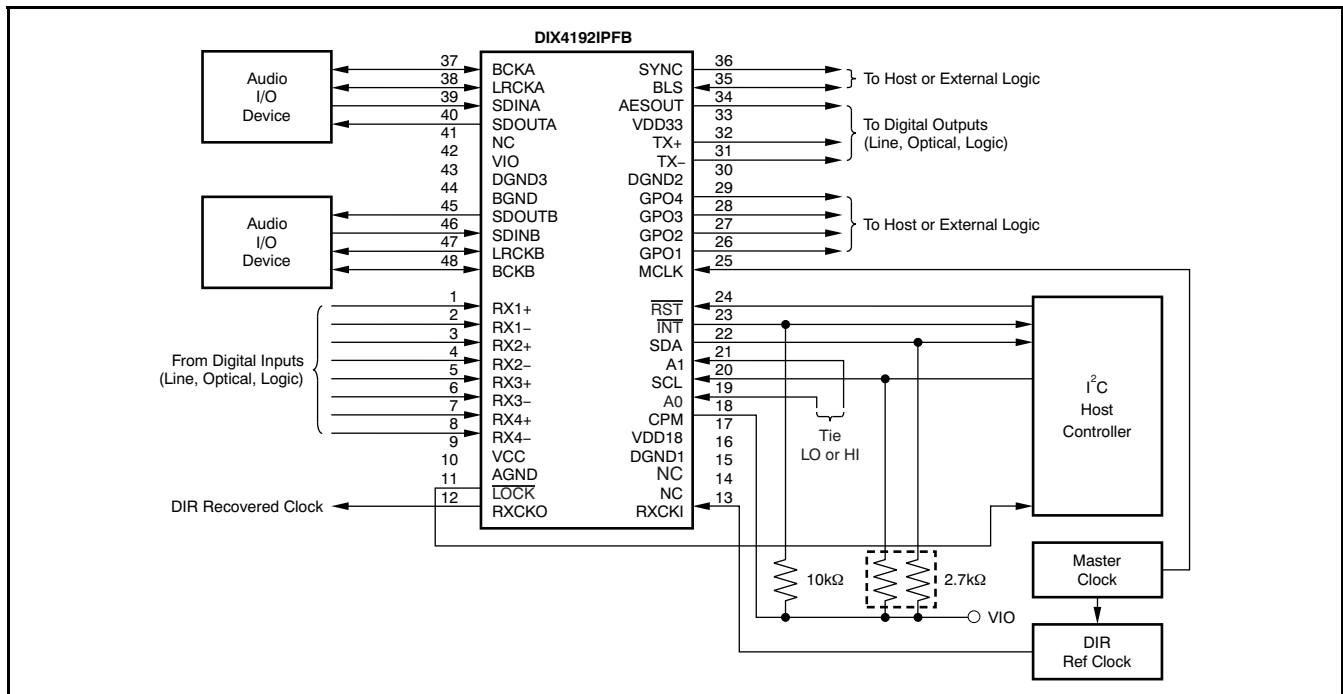
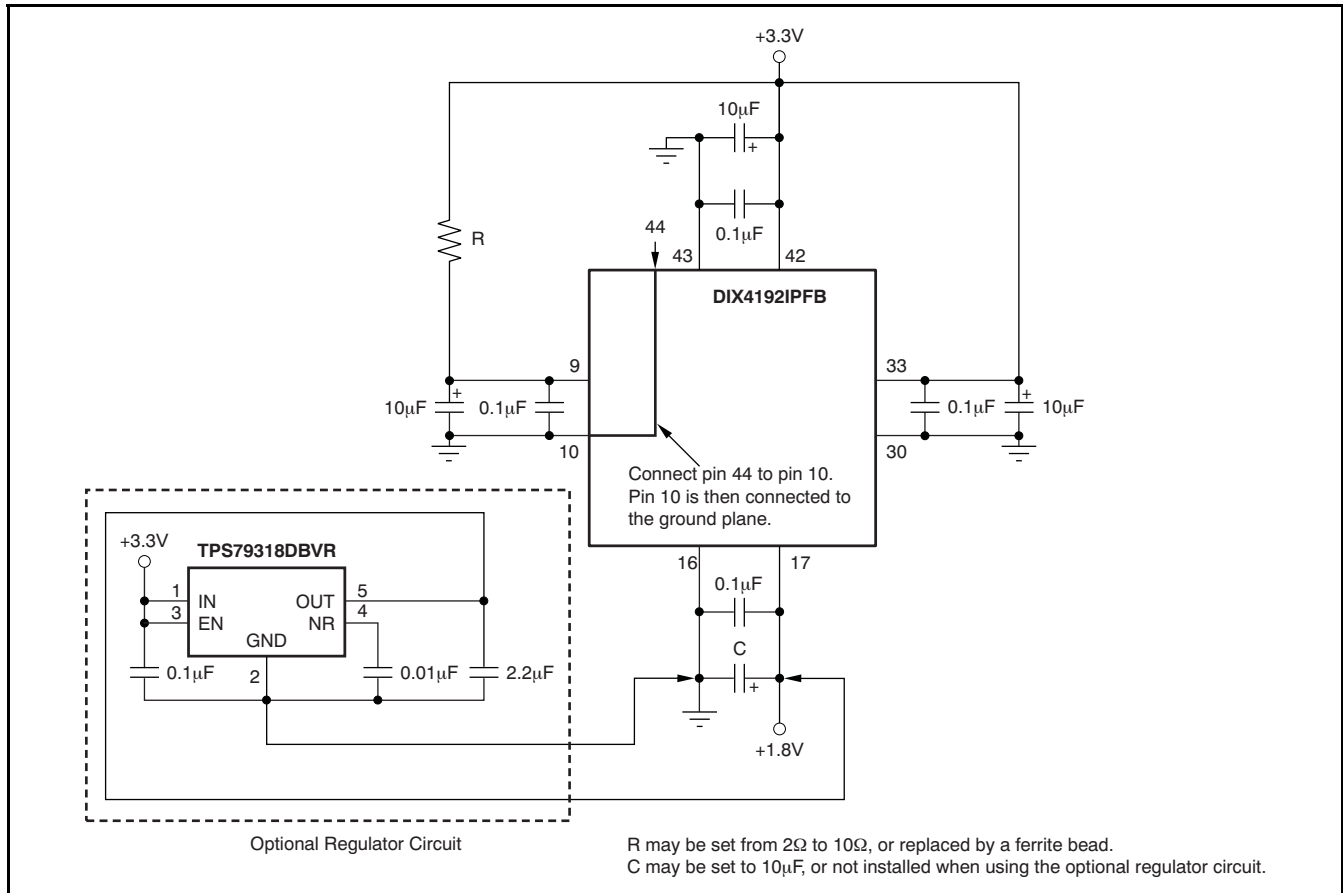


Figure 23. Typical Application Diagram Using I<sup>2</sup>C Host Interface  
(See Figure 24 for Power-Supply Connections.)

**APPLICATIONS INFORMATION (continued)**



**Figure 24. Recommended Power-Supply Connections**

**DIGITAL AUDIO TRANSFORMER VENDORS**

Transformers are shown in this data sheet for both receiver and transmitter balanced and unbalanced line interface implementations. For the Texas Instruments Pro Audio evaluation modules, transformers from Scientific Conversion are utilized. In addition to Scientific Conversion, there are other vendors that offer transformer products for digital audio interface applications. Please refer to the following manufacturer web sites for details regarding their products and services. Other transformer vendors may also be available by searching catalog and/or Internet resources.

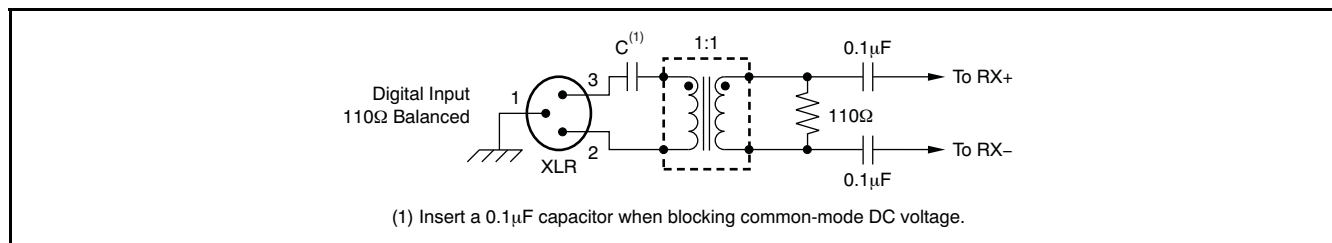
- Scientific Conversion: <http://scientificconversion.com>
- Schott Corporation: <http://schottcorp.com>
- Pulse Engineering: <http://pulseeng.com>

**APPLICATIONS INFORMATION (continued)**

**RECEIVER INPUT INTERFACING**

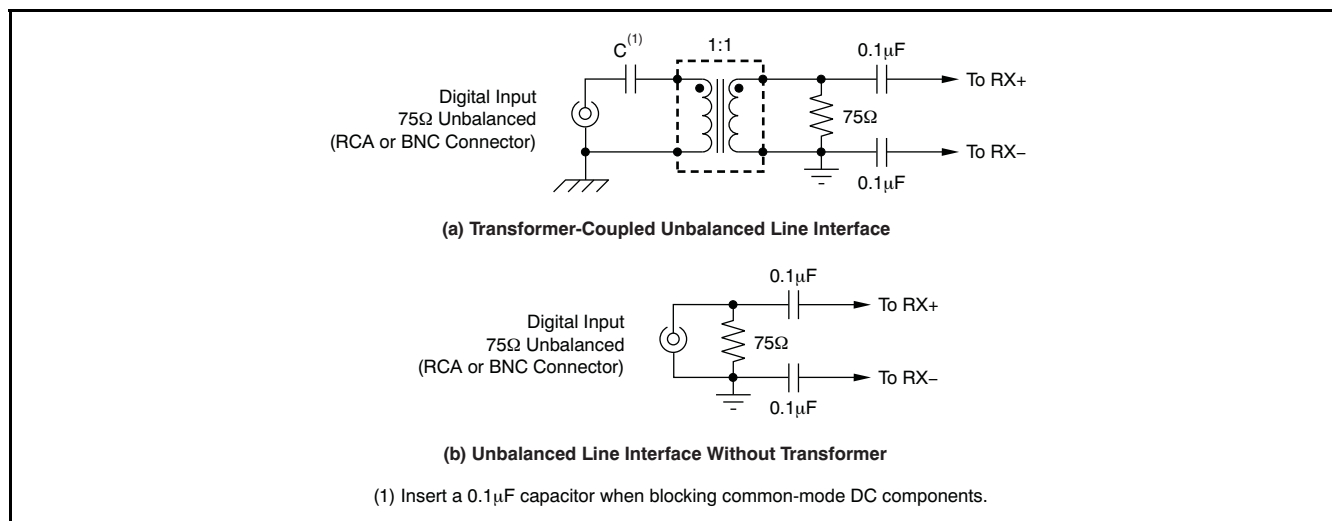
This section details the recommended interfaces for the DIX4192 line receiver inputs. Balanced and unbalanced line interfaces, in addition to optical receiver and external logic interfacing, are discussed.

For professional digital audio interfaces, 110Ω balanced line interfaces are either required or preferred. Transformer coupling is commonly employed to provide isolation and to improve common-mode noise rejection. Figure 25 shows the recommended transformer-coupled balanced line receiver interface for the DIX4192. The transformer is specified for a 1:1 turn ratio, and should exhibit low inter-winding capacitance for best performance. Due to the DC bias on the line receiver inputs, 0.1μF capacitors are utilized for AC-coupling the transformer to the line receiver inputs. On the line side of the transformer, an optional 0.1μF capacitor is shown for cases where a DC bias may be applied at the transmitter side of the connection. The coupling capacitors should be surface-mount ceramic chip type with an X7R or C0G dielectric.



**Figure 25. Transformer-Coupled Balanced Input Interface**

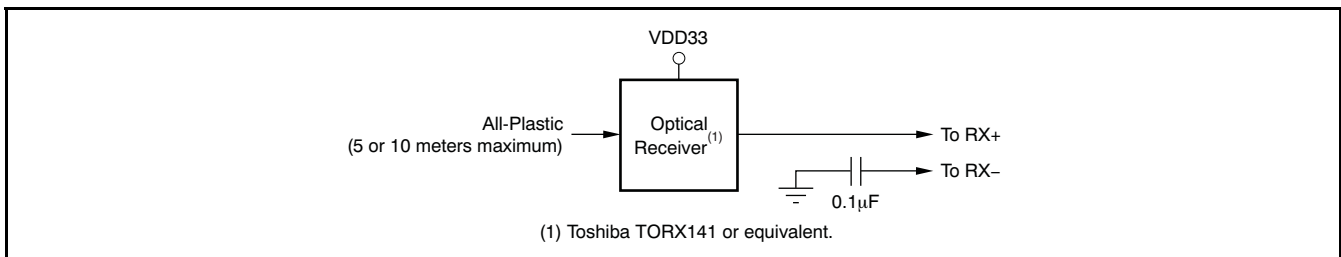
Unbalanced 75Ω coaxial cable interfaces are commonly employed in consumer and broadcast audio applications. Designs with and without transformer line coupling may be utilized. Figure 26(a) shows the recommended 75Ω transformer-coupled line interface, which shares many similarities to the balanced design shown in Figure 25. Once again, the transformer provides isolation and improved noise rejection. Figure 26(b) shows the transformer-free interface, which is commonly used for S/PDIF consumer connections.



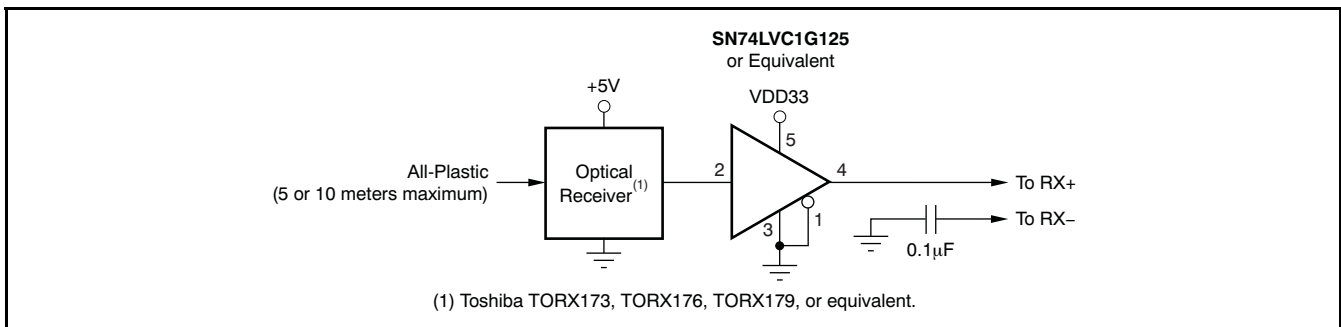
**Figure 26. Unbalanced Line Input Interfaces**

**APPLICATIONS INFORMATION (continued)**

Optical interfaces utilizing all-plastic fiber are commonly employed for consumer audio equipment where interconnections are less than 10m in length. Optical receiver modules utilized for a digital audio interface operate from either a single +3.3V or +5V supply and have a TTL-, CMOS-, or low-voltage CMOS-compatible logic output. Interfacing to +3.3V optical receivers is straightforward when the optical receiver supply is powered from the DIX4192 VDD33 power source, as shown in Figure 27. For the +5V optical receivers, the output high logic level may exceed the DIX4192 line receiver absolute maximum input voltage. A level translator is required, placed between the optical receiver output and the DIX4192 line receiver input. Figure 28 shows the recommended input circuit when interfacing a +5V optical receiver to the DIX4192 line receiver inputs. The Texas Instruments SN74LVC1G125 single buffer IC is operated from the same +3.3V supply used for DIX4192 VDD33 supply. This buffer includes a +5V tolerant digital input, and provides the logic level translation required for the interface.



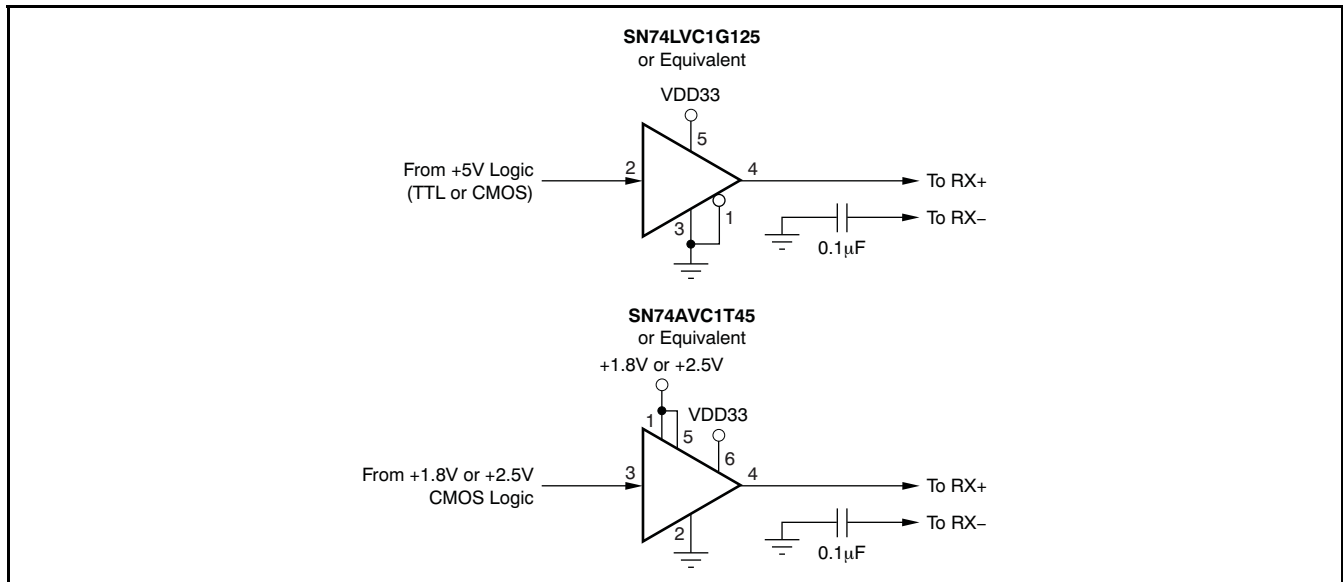
**Figure 27. Interfacing to a +3.3V Optical Receiver Module**



**Figure 28. Interfacing to a +5V Optical Receiver Module**

**APPLICATIONS INFORMATION (continued)**

The DIX4192 line receivers may also be driven directly from external logic or line receiver devices with TTL or CMOS outputs. If the logic driving the line receiver is operated from +3.3V, then logic level translation will not be required. However, if the external logic is operated from a power-supply voltage that exceeds the maximum VDD33 supply voltage of the DIX4192, or operates from a supply voltage lower than +3.3V, then level translation is required. Figure 29 shows the recommended logic level translation methods, utilizing buffers and level translators available from Texas Instruments.

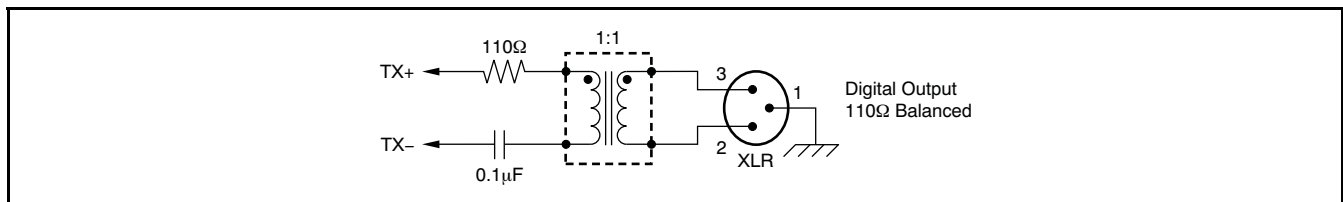


**Figure 29. CMOS/TTL Input Logic Interface**

**TRANSMITTER OUTPUT INTERFACING**

This section details the recommended interfaces for the DIX4192 transmitter line driver and CMOS-buffered outputs. Balanced and unbalanced line interfaces, in addition to optical transmitter and external logic interfacing, will be discussed.

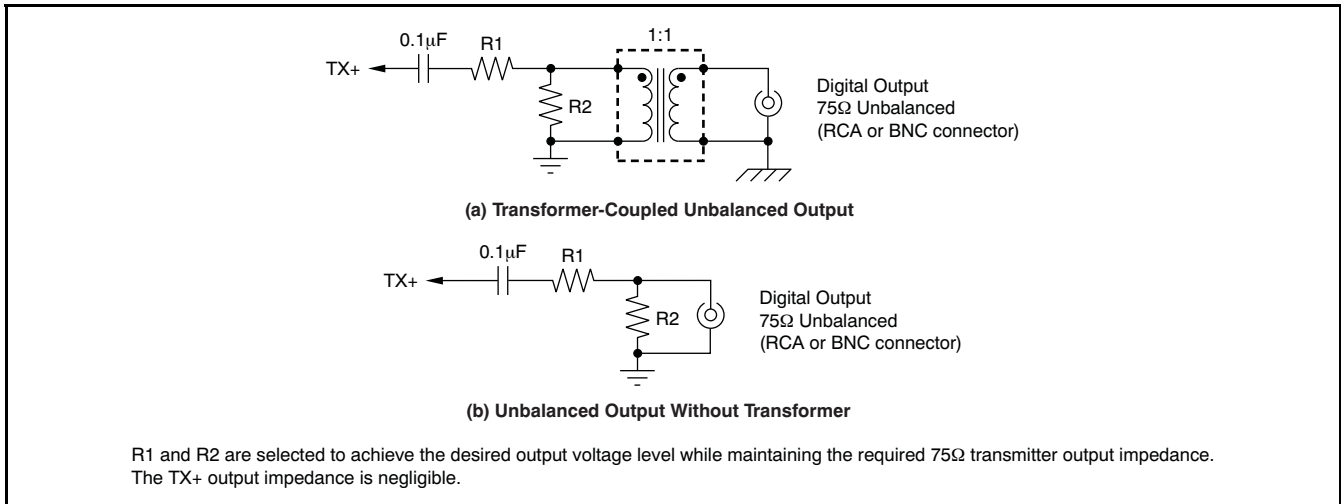
For professional digital audio interfaces, 110Ω balanced line interfaces are either required or preferred. Transformer coupling is commonly employed to provide isolation and to improve common-mode noise performance. Figure 30 shows the recommended transformer-coupled balanced line driver interface for the DIX4192. The transformer is specified for a 1:1 turn ratio, and should exhibit low inter-winding capacitance for best performance. To eliminate residual DC bias, a 0.1µF capacitor is utilized for AC-coupling the transformer to the line driver outputs. The coupling capacitor should be a surface-mount ceramic chip type with an X7R or C0G dielectric.



**Figure 30. Transformer-Coupled Balanced Output Interface**

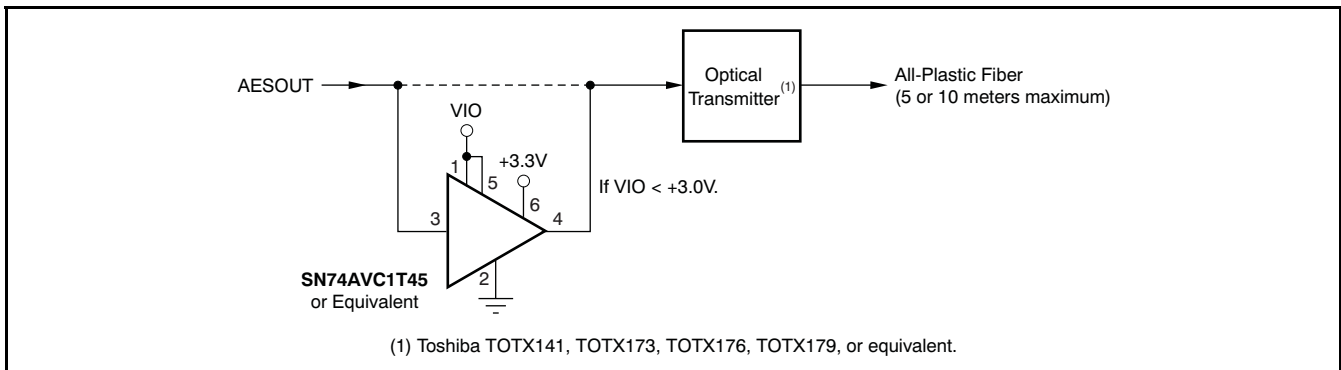
Unbalanced 75Ω coaxial cable interfaces are commonly employed in consumer and broadcast audio applications. Designs with and without transformer line coupling may be utilized. Figure 31(a) illustrates the recommended 75Ω transformer-coupled line driver interface, which shares many similarities to the balanced design shown in Figure 30. Figure 31(b) illustrates the transformer-free line driver interface, which is commonly used for S/PDIF consumer connections.

**APPLICATIONS INFORMATION (continued)**



**Figure 31. Unbalanced Line Output Interfaces**

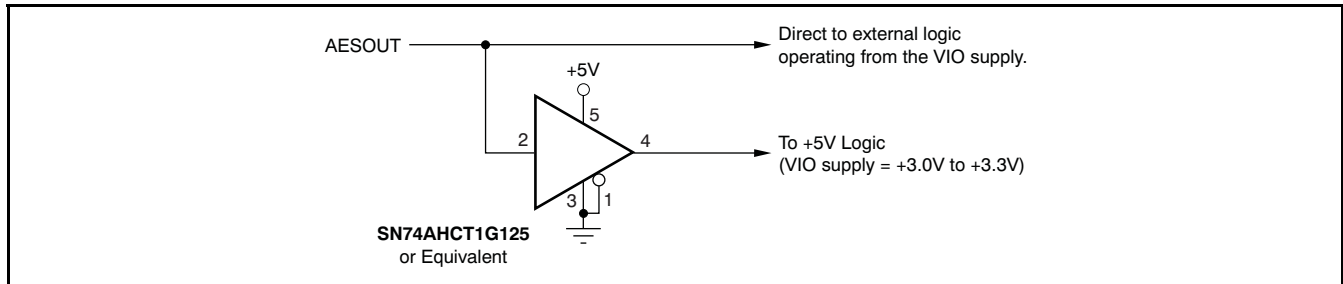
Optical interfaces utilizing all-plastic fiber are commonly employed for consumer audio equipment where interconnections are less than 10m in length. Most optical transmitter modules utilized for a digital audio interface operate from a single +3.3V or +5V supply and have a TTL-compatible logic input. The CMOS-buffered transmitter output of the DIX4192, AESOUT (pin 34), is capable of driving the optical transmitter with VIO supply voltages down to +3.0V. If the VIO supply voltage is less than +3.0V, then level translation logic is required to drive the optical transmitter input. A good choice for this application is the Texas Instruments [SN74AVC1T45](#) single bus transceiver. This device features two power-supply rails, one for the input side and one for the output side. For this application, the input side supply is powered from the VIO supply, while the output side is powered from a +3.3V supply. This configuration will boost the logic high level to a voltage suitable for driving the TTL-compatible input configuration. [Figure 32](#) shows the recommended digital optical transmitter interface circuits.



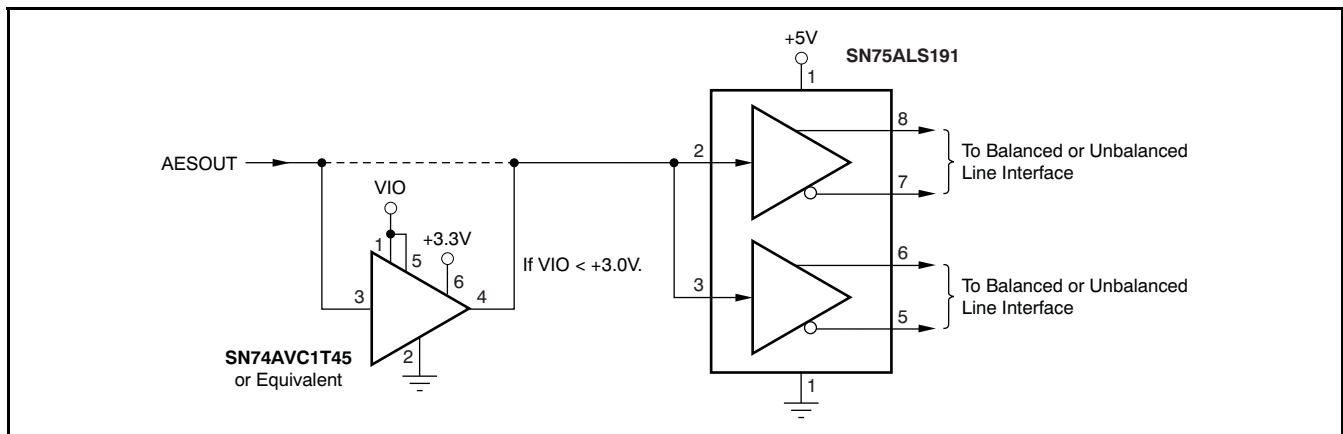
**Figure 32. Interfacing to an Optical Transmitter Module**

The AESOUT output may also be used to drive external logic or line driver devices directly. [Figure 33](#) illustrates the recommended logic interface techniques, including connections with and without level translation. [Figure 34](#) illustrates an external line driver interface utilizing the Texas Instruments [SN75ALS191](#) dual differential line driver. If the VIO supply of the DIX4192 is set from +3.0V to +3.3V, no logic level translation will be required between the AESOUT output and the line driver input. If the VIO supply voltage is below this range, then the optional logic level translation logic of [Figure 34](#) will be required. The SN75ALS191 dual line driver is especially useful in applications where simultaneous 75Ω and 110Ω line interfaces are required.

**APPLICATIONS INFORMATION (continued)**



**Figure 33. CMOS/TTL Output Logic Interface**



**Figure 34. External Line Driver Interface**

**REGISTER AND DATA BUFFER ORGANIZATION**

The DIX4192 organizes the on-chip registers and data buffers into four pages. The currently active page is chosen by programming the Page Selection Register to the desired page number. The Page Selection Register is available on every register page at address 0x7F, allowing easy movement between pages. [Table 2](#) indicates the page selection corresponding to the Page Selection Register value.

**Table 2. Register Page Selection**

Page Selection Register Value (Hex)	Selected Register Page
00	Page 0, control and status registers
01	Page 1, DIR channel status and user data buffers
02	Page 2, DIT channel status and user data buffers
03	Page 3, reserved

Register Page 0 contains the control registers utilized to configure the various function blocks within the DIX4192. In addition, status registers are provided for flag and error conditions, with many of the status bits capable of generating an interrupt signal when enabled. See [Table 3](#) for the control and status register map.

Register Page 1 contains the digital interface receiver (or DIR) channel status and user data buffers. These buffers correspond to the data contained in the C and U bits of the previously received block of the AES3-encoded data stream. The contents of these buffers may be read through the SPI or I<sup>2</sup>C serial host interface and processed as needed by the host system. See [Table 5](#) for the DIR channel status buffer map, and [Table 6](#) for the DIR user data buffer map.



Register Page 2 contains the digital interface transmitter (or DIT) channel status and user data buffers. These buffers correspond to the data contained in the C and U bits of the transmitted AES3-encoded data stream. The contents of these buffers may be written through the SPI or I<sup>2</sup>C serial host interface to configure the C and U bits of the transmitted AES3 data stream. The buffers may also be read for verification by the host system. See [Table 7](#) for the DIT channel status buffer map, and [Table 8](#) for the DIT user data buffer map.

Register Page 3 is reserved for factory test and verification purposes, and cannot be accessed without an unlock code. The unlock code remains private; the test modes disable normal operation of the device, and are not useful in customer applications.

**CONTROL REGISTERS**

See [Table 3](#) for the control and status register map of the DIX4192. Register addresses 0x00 and 0x2D through 0x7E are reserved for factory or future use. All register addresses are expressed as hexadecimal numbers. The following pages provide detailed descriptions for each control and status register.

**Table 3. Control and Status Register Map (Register Page 0)**

ADDRESS (Hex)	D7 (MSB)	D6	D5	D4	D3	D2	D1	D0	REGISTER GROUP
01	RESET	0	PDALL	PDPÄ	PDPB	PDTX	PDRX	0	Power-down and reset
02	0	0	0	0	0	TX	RX	0	Global interrupt status
03	0	AMUTE	AOUTS1	AOUTS0	AM/S	AFMT2	AFMT1	AFMT0	Port A control
04	0	0	0	0	ACLK1	ACLK0	ADIV1	ADIV0	Port A control
05	0	BMUTE	BOUTS1	BOUTS0	BM/S	BFMT2	BFMT1	BFMT0	Port B control
06	0	0	0	0	BCLK1	BCLK0	BDIV1	BDIV0	Port B control
07	TXCLK	TXDIV1	TXDIV0	TXIS1	TXIS0	BLSM	VALID	BSSL	Transmitter control
08	BYPMUX1	BYPMUX0	AESMUX	LDMUX	TXBTD	AESOFF	TXMUTE	TXOFF	Transmitter control
09	0	0	0	0	0	VALSEL	TXCUS1	TXCUS0	Transmitter control
0A	0	0	0	0	0	0	TSLIP	TBTI	DIT status
0B	0	0	0	0	0	0	MTSLIP	MTBTI	DIT interrupt mask
0C	0	0	0	0	TSLIPM1	TSLIPM0	TBTIM1	TBTIM0	DIT interrupt mode
0D	0	0	0	RXBTD	RXCLK	0	RXMUX1	RXMUX	Receiver control
0E	0	0	0	LOL	RXAMLL	RXCKOD1	RXCKOD0	RXCKOE	Receiver control
0F	P3	P2	P1	P0	J5	J4	J3	J2	Receiver PLL configuration
10	J1	J0	D13	D12	D11	D10	D9	D8	Receiver PLL configuration
11	D7	D6	D5	D4	D3	D2	D1	D0	Receiver PLL configuration
12	0	0	0	0	0	0	DTS CD/LD	IEC61937	Non-PCM audio detection
13	0	0	0	0	0	0	RXCKR1	RXCKR0	Receiver status
14	CSCRC	PARITY	VBIT	BPERR	QCHG	UNLOCK	QCRC	RBTI	Receiver status
15	0	0	0	0	0	0	0	OSLIP	Receiver status
16	MCSCRC	MPARITY	MVBIT	MBPERR	MQCHG	MUNLOCK	MQCRC	MRBTI	Receiver interrupt mask
17	0	0	0	0	0	0	0	MOSLIP	Receiver interrupt mask
18	QCHGM1	QCHGM0	UNLOCKM1	UNLOCKM0	QCRCM1	QCRCM0	RBTIM1	RBTIM0	Receiver interrupt mode
19	CSCRCM1	CSCRCM0	PARITYM1	PARITYM0	VBITM1	VBITM0	BPERRM1	BPERRM0	Receiver interrupt mode
1A	0	0	0	0	0	0	OSLIPM1	OSLIPM0	Receiver interrupt mode
1B	0	0	0	0	GPO13	GPO12	GPO11	GPO10	General-purpose out (GPO1)
1C	0	0	0	0	GPO23	GPO22	GPO21	GPO20	General-purpose out (GPO2)
1D	0	0	0	0	GPO33	GPO32	GPO31	GPO30	General-purpose out (GPO3)
1E	0	0	0	0	GPO43	GPO42	GPO41	GPO40	General-purpose out (GPO4)
1F	Q0	Q1	Q2	Q3	Q4	Q5	Q6	Q7	Audio CD Q-channel sub-code
20	Q8	Q9	Q10	Q11	Q12	Q13	Q14	Q15	Audio CD Q-channel sub-code
21	Q16	Q17	Q18	Q19	Q20	Q21	Q22	Q23	Audio CD Q-channel sub-code
22	Q24	Q25	Q26	Q27	Q28	Q29	Q30	Q31	Audio CD Q-channel sub-code
23	Q32	Q33	Q34	Q35	Q36	Q37	Q38	Q39	Audio CD Q-channel sub-code
24	Q40	Q41	Q42	Q43	Q44	Q45	Q46	Q47	Audio CD Q-channel sub-code
25	Q48	Q49	Q50	Q51	Q52	Q53	Q54	Q55	Audio CD Q-channel sub-code
26	Q56	Q57	Q58	Q59	Q60	Q61	Q62	Q63	Audio CD Q-channel sub-code
27	Q64	Q65	Q66	Q67	Q68	Q69	Q70	Q71	Audio CD Q-channel sub-code
28	Q72	Q73	Q74	Q75	Q76	Q77	Q78	Q79	Audio CD Q-channel sub-code
29	PC15	PC14	PC13	PC12	PC11	PC10	PC09	PC08	PC burst preamble, high byte
2A	PC07	PC06	PC05	PC04	PC03	PC02	PC01	PC00	PC burst preamble, low byte
2B	PD15	PD14	PD13	PD12	PD11	PD10	PD09	PD08	PD burst preamble, high byte
2C	PD07	PD06	PD05	PD04	PD03	PD02	PD01	PD00	PD burst preamble, low byte
7F	0	0	0	0	0	0	PAGE1	PAGE0	Page selection

**Register 01: Power-Down and Reset**

Bit 7 (MSB)	Bit 6	Bit 5	Bit 4	Bit 3	Bit 2	Bit 1	Bit 0 (LSB)
RESET	0	PDALL	PDPA	PDPB	PDTX	PDRX	0

**PDRX**

**Power-Down for the Receiver Function Block**

This bit is utilized to power-down the DIR and associated functions. All receiver outputs are forced low.

**PDRX**

**Receiver Power-Down Mode**

0

Enabled (default)

1

Disabled; the Receiver function block will operate normally based upon the applicable control register settings.

**PDTX**

**Power-Down for the Transmitter Function Block**

This bit is utilized to power-down the DIT and associated functions. All transmitter outputs are forced low.

**PDTX**

**Transmitter Power-Down Mode**

0

Enabled (default)

1

Disabled; the Transmitter function block will operate normally based upon the applicable control register settings.

**PDPB**

**Power-Down for Serial Port B**

This bit is utilized to power-down the audio serial I/O Port B. All port outputs are forced low.

**PDPB**

**Port B Power-Down Mode**

0

Enabled (default)

1

Disabled; Port B will operate normally based upon the applicable control register settings.

**PDPA**

**Power-Down for Serial Port A**

This bit is utilized to power-down the audio serial I/O Port A. All port outputs are forced low.

**PDPA**

**Port A Power-Down Mode**

0

Enabled (default)

1

Disabled; Port A will operate normally based upon the applicable control register settings.

**PDALL**

**Power-Down for All Functions**

This bit is utilized to power-down all function blocks except the host interface port and the control and status registers.

**PDALL**

**All Function Power-Down Mode**

0

Enabled (default)

1

Disabled; all function blocks will operate normally based upon the applicable control register settings.

**RESET**

**Software Reset**

This bit is used to force a reset initialization sequence, and is equivalent to forcing an external reset via the  $\overline{RST}$  input (pin 24).

**RESET**

**Reset Function**

0

Disabled (default)

1

Enabled; all control registers will be reset to the default state.

**Register 02: Global Interrupt Status (Read-Only)**

Bit 7 (MSB)	Bit 6	Bit 5	Bit 4	Bit 3	Bit 2	Bit 1	Bit 0 (LSB)
0	0	0	0	0	TX	RX	0

**RX**

**Receiver Function Block Interrupt Status (Active High)**

When set to 1, this bit indicates an active interrupt from the DIR function block. This bit is active high. The user should then read status registers 0x14 and 0x15 in order to determine which of the sources has generated an interrupt.

**TX**

**Transmitter Function Block Interrupt Status (Active High)**

When set to 1, this bit indicates an active interrupt from the DIT function block. This bit is active high. The user should then read status register 0x0A in order to determine which of the sources has generated an interrupt.

**Register 03: Port A Control Register 1**

Bit 7 (MSB)	Bit 6	Bit 5	Bit 4	Bit 3	Bit 2	Bit 1	Bit 0 (LSB)
0	AMUTE	AOUTS1	AOUTS0	AM/S	AFMT2	AFMT1	AFMT0

**AFMT[2:0]**

**Port A Audio Data Format**

These bits are used to set the audio input and output data format for Port A. Refer to the [Audio Serial Port Operation](#) section for illustrations of the supported data formats. Refer to the [Electrical Characteristics: Audio Serial Ports](#) table and [Figure 1](#) for an applicable timing diagram and parameters.

AFMT2	AFMT1	AFMT0	Audio Data Format
0	0	0	24-Bit Left-Justified (default)
0	0	1	24-Bit Philips I <sup>2</sup> S
0	1	0	Unused
0	1	1	Unused
1	0	0	16-Bit Right-Justified
1	0	1	18-Bit Right-Justified
1	1	0	20-Bit Right-Justified
1	1	1	24-Bit Right-Justified

**AM/S**

**Port A Slave/Master Mode**

This bit is used to set the audio clock mode for Port A to either Slave or Master.

AM/S	Slave/Master Mode
0	Slave mode; the LRCK and BCK clocks are inputs generated by an external digital audio source. (default)
1	Master mode; the LRCK and BCK clocks are outputs, derived from the Port A master clock source.

**AOUTS[1:0]**

**Port A Output Data Source**

These bits are used to select the output data source for Port A. The data is output at SDOUTA (pin 40).

AOUTS1	AOUTS0	Output Data Source
0	0	Port A input, for data loop back. (default)
0	1	Port B input
1	0	DIR
1	1	Reserved

**AMUTE**

**Port A Output Mute**

This bit is used to mute the Port A audio data output.

AMUTE	Output Mute
0	Disabled; SDOUTA is driven by the output data source. (default)
1	Enabled; SDOUTA is forced low.

**Register 04: Port A Control Register 2**

Bit 7 (MSB)	Bit 6	Bit 5	Bit 4	Bit 3	Bit 2	Bit 1	Bit 0 (LSB)
0	0	0	0	ACLK1	ACLK0	ADIV1	ADIV0

**ADIV[1:0]**

**Port A Master Clock Divider**

These bits are used to set the master clock divider for generating the LRCKA clock for Port A when configured for Master mode operation. BCKA is always set to 64 times the LRCKA clock rate in Master mode.

ADIV1	ADIV0	Master Mode Clock Divider
0	0	Divide-by-128 (default)
0	1	Divide-by-256
1	0	Divide-by-384
1	1	Divide-by-512

**ACLK[1:0] Port A Master Clock Source**

These bits are used to set the master clock source for Port A when configured for Master mode operation.

ACLK1	ACLK0	Master Clock Source
0	0	MCLK (default)
0	1	RXCKI
1	0	RXCKO
1	1	Reserved

**Register 05: Port B Control Register 1**

Bit 7 (MSB)	Bit 6	Bit 5	Bit 4	Bit 3	Bit 2	Bit 1	Bit 0 (LSB)
0	BMUTE	BOUTS1	BOUTS0	BM/S	BFMT2	BFMT1	BFMT0

**BFMT[2:0] Port B Audio Data Format**

These bits are used to set the audio input and output data format for Port B. Refer to the [Audio Serial Port Operation](#) section for illustrations of the supported data formats. Refer to the [Electrical Characteristics: Audio Serial Ports](#) table and [Figure 1](#) for an applicable timing diagram and parameters.

BFMT2	BFMT1	BFMT0	Audio Data Format
0	0	0	24-Bit Left-Justified (default)
0	0	1	24-Bit Philips I <sup>2</sup> S
0	1	0	Unused
0	1	1	Unused
1	0	0	16-Bit Right-Justified
1	0	1	18-Bit Right-Justified
1	1	0	20-Bit Right-Justified
1	1	1	24-Bit Right-Justified

**BM/S Port B Slave/Master Mode**

This bit is used to set the audio clock mode for Port B to either Slave or Master.

BM/S	Slave/Master Mode
0	Slave mode; the LRCK and BCK clocks are generated by an external source. (default)
1	Master mode; the LRCK and BCK clocks are derived from the Port A master clock source.

**BOUTS[1:0] Port B Output Source**

These bits are used to select the output data source for Port B. The data is output at SDOUTB (pin 45).

BOUTS1	BOUTS0	Output Data Source
0	0	Port B input, for data loop back. (default)
0	1	Port A input
1	0	DIR
1	1	Reserved

**BMUTE Port B Output Mute**

This bit is used to mute the Port B audio data output.

BMUTE	Output Mute
0	Disabled; SDOUTB is driven by the output data source. (default)
1	Enabled; SDOUTB is forced low.

**Register 06: Port B Control Register 2**

Bit 7 (MSB)	Bit 6	Bit 5	Bit 4	Bit 3	Bit 2	Bit 1	Bit 0 (LSB)
0	0	0	0	BCLK1	BCLK0	BDIV1	BDIV0

**BDIV[1:0]**

**Port B Master Mode Clock Divider**

These bits are used to set the master clock divider for generating the LRCKB clock for Port B when configured for Master mode operation. BCKB is always set to 64 times the LRCKB clock rate in Master mode.

BDIV1	BDIV0	Master Mode Clock Divider
0	0	Divide-by-128 (default)
0	1	Divide-by-256
1	0	Divide-by-384
1	1	Divide-by-512

**BCLK[1:0]**

**Port B Master Clock Source**

These bits are used to set the master clock source for Port B when configured for Master mode operation.

BCLK1	BCLK0	Master Clock Source
0	0	MCLK (default)
0	1	RXCKI
1	0	RXCKO
1	1	Reserved

**Register 07: Transmitter Control Register 1**

Bit 7 (MSB)	Bit 6	Bit 5	Bit 4	Bit 3	Bit 2	Bit 1	Bit 0 (LSB)
TXCLK	TXDIV1	TXDIV0	TXIS1	TXIS0	BLSM	VALID	BSSL

**BSSL**

**Block Start or Asynchronous Data Slip Interrupt Trigger Selection**

This bit is used to select the trigger source for the Transmitter TSLIP status and interrupt bit.

BSSL	TSLIP Interrupt Trigger Source
0	Data slip condition (default)
1	Block start condition

**VALID**

**Validity (V) Data Bit**

This bit may be used to set the validity (or V) data bit in the AES3-encoded output. Refer to the VALSEL bit in control register 0x09 for V-bit source selection.

VALID	Transmitted Validity (V) Bit Data
0	Indicates that the transmitted audio data is suitable for conversion to an analog signal or for further digital processing. (default)
1	Indicates that the transmitted audio data is not suitable for conversion to an analog signal or for further digital processing.

**BLSM**

**Transmitter Block Start Input/Output Mode**

This bit is used to select the input/output mode for the DIT block start pin, BLS (pin 35).

BLSM	BLS Pin Mode
0	Input (default)
1	Output

**TXIS[1:0]**

**Transmitter Input Data Source**

These bits are used to select the audio data source for the DIT function block.

TXIS1	TXIS0	Output Word Length
0	0	Port A (default)
0	1	Port B
1	0	DIR
1	1	Reserved

**TXDIV[1:0]**      **Transmitter Master Clock Divider**  
 These bits are used to select the Transmitter master clock divider, which determines the output frame rate.

TXDIV1	TXDIV0	Clock Divider
0	0	Divide the master clock by 128. (default)
0	1	Divide the master clock by 256.
1	0	Divide the master clock by 384.
1	1	Divide the master clock by 512.

**TXCLK**      **Transmitter Master Clock Source**  
 This bit is used to select the master clock source for the Transmitter block.

TXCLK	Transmitter Master Clock Source
0	MCLK input (default)
1	RXCKO; the recovered master clock from the DIR function block.

### Register 08: Transmitter Control Register 2

Bit 7 (MSB)	Bit 6	Bit 5	Bit 4	Bit 3	Bit 2	Bit 1	Bit 0 (LSB)
BYPMUX1	BYPMUX0	AESMUX	LDMUX	TXBTD	AESOFF	TXMUTE	TXOFF

**TXOFF**      **Transmitter Line Driver Output Enable**  
 This bit is used to enable or disable the TX+ (pin 32) and TX– (pin 31) line driver outputs.

TXOFF	Transmitter Line Driver
0	Enabled; the line driver outputs function normally. (default)
1	Disabled; the line driver outputs are forced low.

**TXMUTE**      **Transmitter Audio Data Mute**  
 This bit is used to set the 24 bits of audio and auxiliary data to all zeros for both Channels 1 and 2.

TXMUTE	Transmitter Audio Data Mute
0	Disabled (default)
1	Enabled; the audio data for both channels 1 and 2 are set to all zeros.

**AESOFF**      **AESOUT Output Enable**  
 This bit is used to enable or disable the AESOUT (pin 34) buffered AES3-encoded CMOS logic level output.

AESOFF	AESOUT Output
0	Enabled; the AESOUT pin functions normally. (default)
1	Disabled; the AESOUT pin is forced low.

**TXBTD**      **Transmitter C and U Data Buffer Transfer Disable**  
 This bit is used to enable and disable buffer transfers between the DIT User Access (UA) and DIT Transmitter Access (TA) buffers for both channel status (C) and user (U) data.  
 Buffer transfers may be disabled, allowing the user to write new C and U data to the UA buffers via the SPI or I<sup>2</sup>C serial host interface. Once updated, UA-to-TA buffer transfers may then be re-enabled, allowing the TA buffer to be updated and the new C and U data to be transmitted at the start of the next block.

TXBTD	User Access (UA) to Transmitter Access (TA) Buffer Transfers
0	Enabled (default)
1	Disabled; allows the user to update DIT C and U data buffers.

**Note:** The TXCUS0 and TXCUS1 bits in control register 0x09 must be set to a non-zero value in order for DIT UA buffer updates to occur.

**LDMUX**      **Transmitter Line Driver Input Source Selection**  
 This bit is used to select the input source for the DIT differential line driver outputs.

LDMUX	Line Driver Input Source
0	DIT AES3 encoder output (default)
1	Bypass multiplexer output

**AESMUX**      **AESOUT CMOS Buffer Input Source Selection**  
 This bit is used to select the input source for the AESOUT CMOS logic level output.

AESMUX	AESOUT Buffer Input Source
0	DIT AES3 encoder output (default)
1	Bypass multiplexer output

**BYPMUX[1:0] Bypass Multiplexer Source Selection**

These bits select the line receiver output to be utilized as the bypass multiplexer data source.

BYPMUX1	BYPMUX0	Line Receiver Output Selection
0	0	RX1 (default)
0	1	RX2
1	0	RX3
1	1	RX4

**Register 09: Transmitter Control Register 3**

Bit 7 (MSB)	Bit 6	Bit 5	Bit 4	Bit 3	Bit 2	Bit 1	Bit 0 (LSB)
0	0	0	0	0	VALSEL	TXCUS1	TXCUS0

**TXCUS[1:0] Transmitter Channel Status and User Data Source**

These bits select the source of the channel status (or C) data and user (or U) data which is used to load the DIT User Access (UA) buffers.

TXCUS1	TXCUS0	DIT UA Buffer Source
0	0	The buffers will not be updated. (default)
0	1	The buffers are updated via the SPI or I <sup>2</sup> C host interface.
1	0	The buffers are updated via the DIR RA buffers.
1	1	The first 10 bytes of the buffers are updated via the SPI or I <sup>2</sup> C host, while the remainder of the buffers are updated via the DIR RA buffers.

**VALSEL Transmitter Validity Bit Source**

This bit is utilized to select the source for the validity (or V) bit in the AES3-encoded output data stream.

VALSEL	Validity (or V) Bit Source Selection
0	The VALID bit in control register 0x07.
1	The V bit is transferred from the DIR block with zero latency.

**Register 0A: DIT Status (Read-Only)**

Bit 7 (MSB)	Bit 6	Bit 5	Bit 4	Bit 3	Bit 2	Bit 1	Bit 0 (LSB)
0	0	0	0	0	0	TSLIP	TBTI

**TBTI Transmitter Buffer Transfer Status, Active High**

When DIT User Access (UA) to Transmitter Access (TA) buffer transfers are enabled (the TXBTD bit in control register 0x08 is set to 0), and the TBTI interrupt is unmasked (the MTBTI bit in control register 0x0B is set to 1), the TBTI bit will be set to 1 when the UA-to-TA buffer transfer has completed. This configuration also causes the  $\overline{\text{INT}}$  output (pin 23) to be driven low and the TX bit in status register 0x02 to be set to 1, indicating that an interrupt has occurred.

**TSLIP Transmitter Source Data Slip Status, Active High**

The TSLIP bit will be set to 1 when either an asynchronous data slip or block start condition is detected, and the TSLIP interrupt is unmasked (the MTSLIP bit in control register 0x0B is set to 1). The BSSL bit in control register 0x07 is used to set the source for this interrupt. The TSLIP bit being forced to 1 will also cause the  $\overline{\text{INT}}$  output (pin 23) to be driven low and the TX bit in status register 0x02 to be set to 1, indicating that an interrupt has occurred.

**Register 0B: DIT Interrupt Mask Register**

Bit 7 (MSB)	Bit 6	Bit 5	Bit 4	Bit 3	Bit 2	Bit 1	Bit 0 (LSB)
0	0	0	0	0	0	MTSLIP	MTBTI

**MBTI Transmitter Buffer Transfer Interrupt Mask**

MTBI	BTI Interrupt Mask
0	BTI interrupt is masked. (default)
1	BTI interrupt is enabled.

**MTSLIP Transmitter TSLIP Interrupt Mask**

MTSLIP	TSLIP Interrupt Mask
0	TSLIP interrupt is masked. (default)
1	TSLIP interrupt is enabled.



**Register 0C: DIT Interrupt Mode Register**

Bit 7 (MSB)	Bit 6	Bit 5	Bit 4	Bit 3	Bit 2	Bit 1	Bit 0 (LSB)
0	0	0	0	TSLIPM1	TSLIPM0	TBTIM1	TBTIM0

**TBTIM[1:0]**

**Transmitter Buffer Transfer Interrupt Mode**

These bits are utilized to select the active trigger state for the BTI interrupt.

TBTIM1	TBTIM0	Interrupt Active State
0	0	Rising edge active (default)
0	1	Falling edge active
1	0	Level active
1	1	Reserved

**TSLIPM[1:0]**

**Transmitter Data Source Slip Interrupt Mode**

These bits are utilized to select the active trigger state for the TSLIP interrupt.

TSLIPM1	TSLIPM0	Interrupt Active State
0	0	Rising edge active (default)
0	1	Falling edge active
1	0	Level active
1	1	Reserved

**Register 0D: Receiver Control Register 1**

Bit 7 (MSB)	Bit 6	Bit 5	Bit 4	Bit 3	Bit 2	Bit 1	Bit 0 (LSB)
0	0	0	RXBDT	RXCLK	0	RXMUX1	RXMUX0

**RXMUX[1:0]**

**Receiver Input Source Selection**

These bits are used to select the output of the line receiver to be used as the input data source for the DIR core.

RXMUX1	RXMUX0	Input Selection
0	0	RX1 (default)
0	1	RX2
1	0	RX3
1	1	RX4

**RXCLK**

**Receiver Reference Clock Source**

This bit is used to select the reference clock source for PLL1 in the DIR core.

RXCLK	Receiver Reference Clock
0	RXCKI (default)
1	MCLK

**RXBDT**

**Receiver C and U Data Buffer Transfer Disable**

This bit is used to enable and disable buffer transfers between the Receiver Access (RA) and User Access (UA) buffers for both channel status (C) and user (U) data.

Buffer transfers are typically disabled to allow the customer to read C and U data from the DIR UA buffer via the SPI or I<sup>2</sup>C serial host interface. Once read, the RA-to-UA buffer transfer can be re-enabled to allow the RA buffer to update the contents of the UA buffer in real time.

RXBDT	Receiver Access (RA) to User Access (UA) Buffer Transfers
0	Enabled (default)
1	Disabled; the user may read C and U data from the DIR UA buffers.

**Register 0E: Receiver Control Register 2**

Bit 7 (MSB)	Bit 6	Bit 5	Bit 4	Bit 3	Bit 2	Bit 1	Bit 0 (LSB)
0	0	0	LOL	RXAMLL	RXCKOD1	RXCKOD0	RXCKOE

**RXCKOE**

**RXCKOE Output Enable**

This bit is used to enable or disable the recovered clock output, RXCKO (pin 12). When disabled, the output is set to a high-impedance state.

**RXCKOE**

**RXCKO Output State**

0	Disabled; the RXCKO output is set to high-impedance. (default)
1	Enabled; the recovered master clock is available at RXCKO.

**RXCKOD[1:0]**

**RXCKO Output Clock Divider**

These bits are utilized to set the clock divider at the output of PLL2. The output of the divider is the RXCKO clock, available internally or at the RXCKO output (pin 12).

**RXCKOD1**

**RXCKOD0**

**RXCKO Output Divider**

0	0	Passthrough; no division is performed. (default)
0	1	Divide the PLL2 clock output by 2.
1	0	Divide the PLL2 clock output by 4.
1	1	Divide the PLL2 clock output by 8.

**RXAMLL**

**Receiver Automatic Mute for Loss of Lock**

This bit is used to set the automatic mute function for the DIR block when a loss of lock is indicated by both the AES3 decoder and PLL2.

**RXAMLL**

**Receiver Auto-Mute Function**

0	Disabled (default)
1	Enabled; audio data output from the DIR block is forced low for a loss of lock condition.

**LOL**

**Receiver Loss of Lock Mode for the Recovered Clock (output from PLL2)**

This bit is used to set the mode of operation for PLL2 when a loss of lock condition occurs.

**LOL**

**Receiver PLL2 Operation**

0	The PLL2 output clock is stopped for a loss of lock condition. (default)
1	The PLL2 output clock free runs when a loss of lock condition occurs.

**Register 0F: Receiver PLL1 Configuration Register 1**

Bit 7 (MSB)	Bit 6	Bit 5	Bit 4	Bit 3	Bit 2	Bit 1	Bit 0 (LSB)
P3	P2	P1	P0	J5	J4	J3	J2

**Register 10: Receiver PLL1 Configuration Register 2**

Bit 7 (MSB)	Bit 6	Bit 5	Bit 4	Bit 3	Bit 2	Bit 1	Bit 0 (LSB)
J1	J0	D13	D12	D11	D10	D9	D8

**Register 11: Receiver PLL1 Configuration Register 3**

Bit 7 (MSB)	Bit 6	Bit 5	Bit 4	Bit 3	Bit 2	Bit 1	Bit 0 (LSB)
D7	D6	D5	D4	D3	D2	D1	D0

Registers 0x0F through 0x11 are utilized to program PLL1 in the DIR core. PLL1 multiplies the DIR reference clock source to an oversampling rate which is adequate for AES3 decoder operation. PLL1 is programmed using the following relationship:

$$(\text{CLOCK} \times K) / P = 98.304\text{MHz}$$

where:

CLOCK = frequency of the DIR reference clock source.

$K = J.D$ , where the integer part  $J = 1$  to 63, and the fractional part  $D = 0$  to 9999.

$P$  = the pre-divider value, which may be set to any 4-bit value that meets the conditions stated below.

The following conditions must be met for the values of  $P$ ,  $J$ , and  $D$ :

**If  $D = 0$ , then:**

$$2 \text{ MHz} \leq (\text{CLOCK} / P) \leq 20 \text{ MHz and } 4 \leq J \leq 55.$$

Referring to registers 0x0F through 0x11:

$P$  is programmed using bits  $P[3:0]$ .

$J$  is programmed using bits  $J[5:0]$ .

$D$  is programmed using bits  $D[13:0]$ .

Table 4 shows values for  $P$ ,  $J$ , and  $D$  for common DIR reference clock rates.

**If  $D \neq 0$ , then:**

$$10 \text{ MHz} \leq (\text{CLOCK} / P) \leq 20 \text{ MHz and } 4 \leq J \leq 11.$$

**Table 4. PLL1 Register Values for Common Reference Clock Rates**

REFERENCE CLOCK RATE (MHz)	P	J	D	ERROR (%)
8.1920	1	12	0	0.0000
11.2896	1	8	7075	0.0002
12.2880	1	8	0	0.0000
16.3840	1	6	0	0.0000
22.5792	2	8	7075	0.0002
24.5760	2	8	0	0.0000
27.0000	2	7	2818	0.0003

**Register 12: Non-PCM Audio Detection Status Register (Read-Only)**

Bit 7 (MSB)	Bit 6	Bit 5	Bit 4	Bit 3	Bit 2	Bit 1	Bit 0 (LSB)
0	0	0	0	0	0	DTS CD/LD	IEC61937

**IEC61937** This bit is utilized to indicate the detection of an IEC 61937 data reduced audio format (includes Dolby AC-3, DTS, etc.) for DVD playback or general transmission purposes.

IEC61937	Status
0	Data is not an IEC61937 format.
1	Data is an IEC61937 format. Refer to the PC and PD preamble registers (addresses 0x29 through 0x2C) for data type and burst length.

**DTS CD/LD** This bit is used to indicate the detection of a DTS encoded audio compact disc (CD) or Laserdisc (LD) playback.

DTS CD/LD	Status
0	The CD/LD is not DTS-encoded.
1	DTS CD/LD playback detected.

**Register 13: Receiver Status Register 1 (Read-Only)**

Bit 7 (MSB)	Bit 6	Bit 5	Bit 4	Bit 3	Bit 2	Bit 1	Bit 0 (LSB)
0	0	0	0	0	0	RXCKR1	RXCKR0

**RXCKR[1:0]**

**Maximum Available Recovered Clock Rate**

These two bits indicate the maximum available RXCKO clock rate based upon the DIR detection circuitry, which determines the frame rate of the incoming AES3-encoded bit stream. Based upon the estimated frame rate, a maximum rate for the recovered clock output (RXCKO) is determined and output from PLL2, as well as being loaded into the RXCKR0 and RXCKR1 status bits. The status of the RXCKR0 and RXCKR1 bits may be utilized to determine the programmed value for the PLL2 output clock divider, set by the RXCKOD0 and RXCKOD1 bits in control register 0x0E.

RXCKR1	RXCKR0	Maximum Available RXCKO Rate
0	0	Clock rate not determined.
0	1	128f <sub>s</sub>
1	0	256f <sub>s</sub>
1	1	512f <sub>s</sub>

**Register 14: Receiver Status Register 2 (Read-Only)**

Bit 7 (MSB)	Bit 6	Bit 5	Bit 4	Bit 3	Bit 2	Bit 1	Bit 0 (LSB)
CSCRC	PARITY	VBIT	BPERR	QCHG	UNLOCK	QCRC	RBTI

Note: Status bits must be unmasked in control register 0x16 in order for the status interrupts to be generated.

**CSCRC**

**Channel Status CRC Status**

CSCRC	CRC Status
0	No error
1	CRC error detected

**PARITY**

**Parity Status**

PARITY	Parity Status
0	No error
1	Parity error detected

**VBIT**

**Validity Bit Status**

VBIT	Validity Bit
0	Valid audio data indicated
1	Non-valid data indicated

**BPERR**

**Biphase Encoding Error Status**

BPERR	Biphase Encoding Status
0	No error
1	Biphase encoding error detected

**QCHG**

**Q-Channel Sub-Code Data Change Status**

QCHG	Q-Channel Data Status
0	No change in Q-channel sub-code data.
1	Q-channel data has changed. May be used to trigger a read of the Q-channel sub-code data, registers 0x1F through 0x28.

**UNLOCK**

**DIR Unlock Error Status**

UNLOCK	DIR Lock Status
0	No error; the DIR AES3 decoder and PLL2 are locked.
1	DIR lock error; the AES3 decoder and PLL2 are unlocked.

**QCRC**

**Q-Channel Sub-Code CRC Status**

QCRC	Q-Channel CRC Status
0	No error
1	Q-channel sub-code data CRC error detected.

**RBTI**

**Receiver Buffer Transfer Interrupt Status**

RBTI	DIR RA Buffer-to-UA Buffer Transfer Status
0	Buffer transfer incomplete, or no Buffer transfer interrupt indicated

1 Buffer transfer completed

**Register 15: Receiver Status Register 3 (Read-Only)**

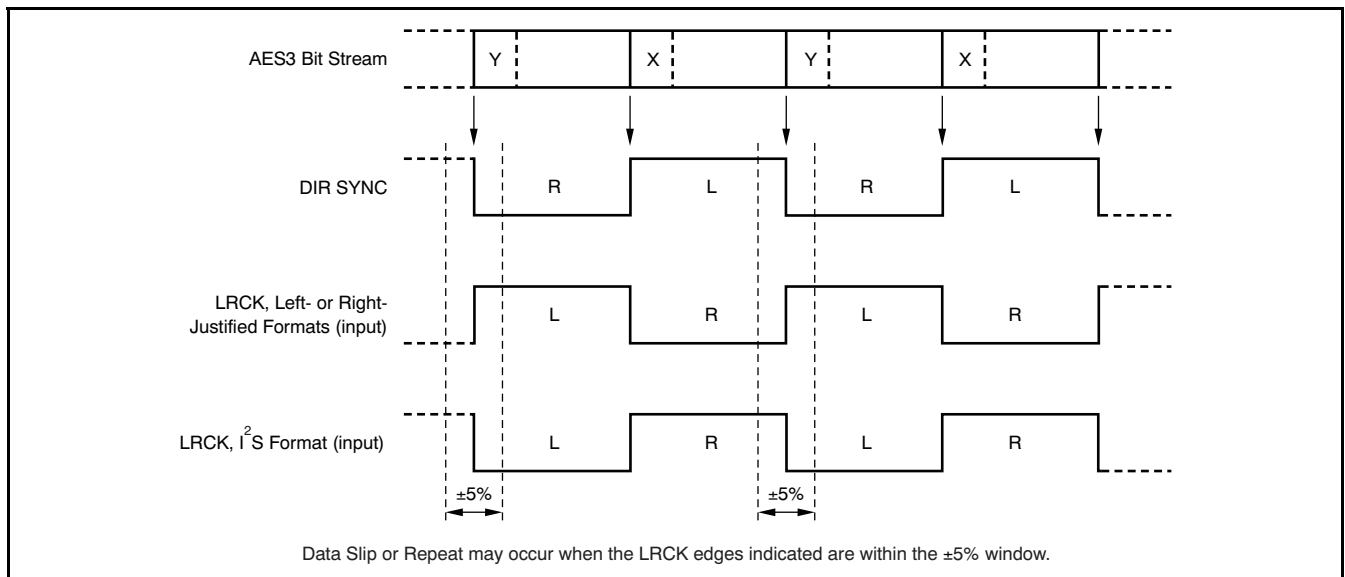
Bit 7 (MSB)	Bit 6	Bit 5	Bit 4	Bit 3	Bit 2	Bit 1	Bit 0 (LSB)
0	0	0	0	0	0	0	OSLIP

Note: Status bits must be unmasked in control register 0x17 in order for the status interrupts to be generated.

<b>OSLIP</b>	<b>Receiver Output Data Slip Error Status</b>
	<b>OSLIP</b>
	0 No error
	1 DIR output data Slip/Repeat error detected

An OSLIP interrupt is possible when the DIR output is used as the source for either the Port A or Port B audio serial port and the port is configured to operate in slave mode. Figure 35 shows the timing associated with the OSLIP interrupt.

When only one audio serial port (Port A or Port B) is sourced by the DIR output, then the OSLIP status bit and interrupt applies to that port. If both Port A and Port B are sourced by the DIR output, then the OSLIP status bit and interrupt applies to Port A only.



**Figure 35. DIR Output Slip/Repeat (OSLIP) Behavior**

**Register 16: Receiver Interrupt Mask Register 1**

Bit 7 (MSB)	Bit 6	Bit 5	Bit 4	Bit 3	Bit 2	Bit 1	Bit 0 (LSB)
MCSCRC	MPARITY	MVBIT	MBPERR	MQCHG	MUNLOCK	MQCRC	MRBTI

<b>MCSCRC</b>	<b>Channel Status CRC Error Interrupt Mask</b>
	<b>MCSCRC</b>
	0 Masked (default)
	1 Enabled
<b>MPARITY</b>	<b>Parity Error Interrupt Mask</b>
	<b>MPARITY</b>
	0 Masked (default)
	1 Enabled
<b>MVBIT</b>	<b>Validity Error Interrupt Mask</b>
	<b>MVBIT</b>
	0 Masked (default)
	1 Enabled

<b>MBPERR</b>	<b>Biphase Encoding Error Interrupt Mask</b>	
	<b>MBPERR</b>	<b>Biphase Error Interrupt</b>
	0	Masked (default)
	1	Enabled
<b>MQCHG</b>	<b>Q-Channel Sub-Code Data Change Interrupt Mask</b>	
	<b>MQCHG</b>	<b>Q-Channel Data Change Interrupt</b>
	0	Masked (default)
	1	Enabled
<b>MUNLOCK</b>	<b>DIR Unlock Error Interrupt Mask</b>	
	<b>MUNLOCK</b>	<b>DIR Unlock Interrupt</b>
	0	Masked (default)
	1	Enabled
<b>MQCRC</b>	<b>Q-Channel Sub-Code CRC Error Interrupt Mask</b>	
	<b>MQCRC</b>	<b>Q-Channel CRC Error Interrupt</b>
	0	Masked (default)
	1	Enabled
<b>MRBTI</b>	<b>Receiver Buffer Transfer Interrupt Mask</b>	
	<b>MRBTI</b>	<b>Receiver Buffer Transfer Interrupt</b>
	0	Masked (default)
	1	Enabled

**Register 17: Receiver Interrupt Mask Register 2**

Bit 7 (MSB)	Bit 6	Bit 5	Bit 4	Bit 3	Bit 2	Bit 1	Bit 0 (LSB)
0	0	0	0	0	0	0	MOSLIP

<b>MOSLIP</b>	<b>Receiver Output Data Slip Error Mask</b>	
	<b>MOSLIP</b>	<b>Receiver OSLIP Error Interrupt</b>
	0	Masked (default)
	1	Enabled

**Register 18: Receiver Interrupt Mode Register 1**

Bit 7 (MSB)	Bit 6	Bit 5	Bit 4	Bit 3	Bit 2	Bit 1	Bit 0 (LSB)
QCHGM1	QCHGM0	UNLOCKM1	UNLOCKM0	QCRCM1	QCRCM0	RBTIM1	RBTIM0

<b>QCHGM[1:0]</b>	<b>Q-Channel Sub-Code Data Change Interrupt Mode</b>		
	<b>QCHGM1</b>	<b>QCHGM0</b>	<b>Interrupt Active State</b>
	0	0	Rising edge active (default)
	0	1	Falling edge active
	1	0	Level active
	1	Reserved	

<b>UNLOCKM[1:0]</b>	<b>DIR Unlock Error Interrupt Mode</b>		
	<b>UNLOCKM1</b>	<b>UNLOCKM0</b>	<b>Interrupt Active State</b>
	0	0	Rising edge active (default)
	0	1	Falling edge active
	1	0	Level active
	1	Reserved	

<b>QCRCM[1:0]</b>	<b>Q-Channel Sub-Code CRC Error Interrupt Mode</b>		
	<b>QCRCM1</b>	<b>QCRCM0</b>	<b>Interrupt Active State</b>
	0	0	Rising edge active (default)
	0	1	Falling edge active
	1	0	Level active
	1	Reserved	

<b>RBTIM[1:0]</b>	<b>Receive Buffer Transfer Interrupt Mode</b>		
	<b>RBTIM1</b>	<b>RBTIM0</b>	<b>Interrupt Active State</b>
	0	0	Rising edge active (default)
	0	1	Falling edge active
	1	0	Level active
	1	1	Reserved

**Register 19: Receiver Interrupt Mode Register 2**

Bit 7 (MSB)	Bit 6	Bit 5	Bit 4	Bit 3	Bit 2	Bit 1	Bit 0 (LSB)
CSCRCM1	CSCRCM0	PARITYM1	PARITYM0	VBITM1	VBITM0	BPERRM1	BPERRM0

<b>CSCRCM[1:0]</b>	<b>Channel Status CRC Error Interrupt Mode</b>		
	<b>CSCRCM1</b>	<b>CSCRCM0</b>	<b>Interrupt Active State</b>
	0	0	Rising edge active (default)
	0	1	Falling edge active
	1	0	Level active
	1	1	Reserved

<b>PARITYM[1:0]</b>	<b>Parity Error Interrupt Mode</b>		
	<b>PARITYM1</b>	<b>PARITYM0</b>	<b>Interrupt Active State</b>
	0	0	Rising edge active (default)
	0	1	Falling edge active
	1	0	Level active
	1	1	Reserved

<b>VBITM[1:0]</b>	<b>Validity Error Interrupt Mode</b>		
	<b>VBITM1</b>	<b>VBITM0</b>	<b>Interrupt Active State</b>
	0	0	Rising edge active (default)
	0	1	Falling edge active
	1	0	Level active
	1	1	Reserved

<b>BPERRM[1:0]</b>	<b>Biphase Encoding Error Interrupt Mode</b>		
	<b>BPERRM1</b>	<b>BPERRM0</b>	<b>Interrupt Active State</b>
	0	0	Rising edge active (default)
	0	1	Falling edge active
	1	0	Level active
	1	1	Reserved

**Register 1A: Receiver Interrupt Mode Register 3**

Bit 7 (MSB)	Bit 6	Bit 5	Bit 4	Bit 3	Bit 2	Bit 1	Bit 0 (LSB)
0	0	0	0	0	0	OSLIPM1	OSLIPM0

<b>OSLIPM[1:0]</b>	<b>Receiver Output Data Slip Error Interrupt Mode</b>		
	<b>OSLIPM1</b>	<b>OSLIPM0</b>	<b>Interrupt Active State</b>
	0	0	Rising edge active (default)
	0	1	Falling edge active
	1	0	Level active
	1	1	Reserved

**Register 1B: General-Purpose Output 1 (GPO1) Control Register**

Bit 7 (MSB)	Bit 6	Bit 5	Bit 4	Bit 3	Bit 2	Bit 1	Bit 0 (LSB)
0	0	0	0	GPO13	GPO12	GPO11	GPO10

**GPO[13:10] General-Purpose Output 1 (GPO1) Configuration**

These bits are used to set the state or data source for the general-purpose digital output pin GPO1.

GPO13	GPO12	GPO11	GPO10	GPO1 Function
0	0	0	0	GPO1 is forced low (default)
0	0	0	1	GPO1 is forced high
0	0	1	0	Reserved
0	0	1	1	Transmitter interrupt, active low
0	1	0	0	Receiver interrupt, active low
0	1	0	1	Receiver 50/15µs pre-emphasis, active low
0	1	1	0	Receiver non-audio data, active high
0	1	1	1	Receiver non-valid data, active high
1	0	0	0	Receiver channel status bit
1	0	0	1	Receiver user data bit
1	0	1	0	Receiver block start clock
1	0	1	1	Receiver COPY bit (0 = copyright asserted, 1 = copyright not asserted)
1	1	0	0	Receiver L-bit (0 = first generation or higher, 1 = original)
1	1	0	1	Receiver parity error, active high
1	1	1	0	Receiver internal sync clock
1	1	1	1	Transmitter internal sync clock

**Register 1C: General-Purpose Output 2 (GPO2) Control Register**

Bit 7 (MSB)	Bit 6	Bit 5	Bit 4	Bit 3	Bit 2	Bit 1	Bit 0 (LSB)
0	0	0	0	GPO23	GPO22	GPO21	GPO20

**GPO[23:20] General-Purpose Output 2 (GPO2) Configuration**

These bits are used to set the state or data source for the general-purpose digital output pin GPO2.

GPO23	GPO22	GPO21	GPO20	GPO2 Function
0	0	0	0	GPO2 is forced low (default)
0	0	0	1	GPO2 is forced high
0	0	1	0	Reserved
0	0	1	1	Transmitter interrupt, active low
0	1	0	0	Receiver interrupt, active low
0	1	0	1	Receiver 50/15µs pre-emphasis, active low
0	1	1	0	Receiver non-audio data, active high
0	1	1	1	Receiver non-valid data, active high
1	0	0	0	Receiver channel status bit
1	0	0	1	Receiver user data bit
1	0	1	0	Receiver block start clock
1	0	1	1	Receiver COPY bit (0 = copyright asserted, 1 = copyright not asserted)
1	1	0	0	Receiver L-bit (0 = first generation or higher, 1 = original)
1	1	0	1	Receiver parity error, active high
1	1	1	0	Receiver internal sync clock
1	1	1	1	Transmitter internal sync clock



**Register 1D: General-Purpose Output 3 (GPO3) Control Register**

Bit 7 (MSB)	Bit 6	Bit 5	Bit 4	Bit 3	Bit 2	Bit 1	Bit 0 (LSB)
0	0	0	0	GPO33	GPO32	GPO31	GPO30

**GPO[33:30] General-Purpose Output 3 (GPO3) Configuration**

These bits are used to set the state or data source for the general-purpose digital output pin GPO3.

GPO33	GPO32	GPO31	GPO30	GPO3 Function
0	0	0	0	GPO3 is forced low (default)
0	0	0	1	GPO3 is forced high
0	0	1	0	Reserved
0	0	1	1	Transmitter interrupt, active low
0	1	0	0	Receiver interrupt, active low
0	1	0	1	Receiver 50/15 $\mu$ s pre-emphasis, active low
0	1	1	0	Receiver non-audio data, active high
0	1	1	1	Receiver non-valid data, active high
1	0	0	0	Receiver channel status bit
1	0	0	1	Receiver user data bit
1	0	1	0	Receiver block start clock
1	0	1	1	Receiver COPY bit (0 = copyright asserted, 1 = copyright not asserted)
1	1	0	0	Receiver L-bit (0 = first generation or higher, 1 = original)
1	1	0	1	Receiver parity error, active high
1	1	1	0	Receiver internal sync clock
1	1	1	1	Transmitter internal sync clock

**Register 1E: General-Purpose Output 4 (GPO4) Control Register**

Bit 7 (MSB)	Bit 6	Bit 5	Bit 4	Bit 3	Bit 2	Bit 1	Bit 0 (LSB)
0	0	0	0	GPO43	GPO42	GPO41	GPO40

**GPO[43:40] General-Purpose Output 4 (GPO4) Configuration**

These bits are used to set the state or data source for the general-purpose digital output pin GPO4.

GPO43	GPO42	GPO41	GPO40	GPO4 Function
0	0	0	0	GPO4 is forced low (default)
0	0	0	1	GPO4 is forced high
0	0	1	0	Reserved
0	0	1	1	Transmitter interrupt, active low
0	1	0	0	Receiver interrupt, active low
0	1	0	1	Receiver 50/15 $\mu$ s pre-emphasis, active low
0	1	1	0	Receiver non-audio data, active high
0	1	1	1	Receiver non-valid data, active high
1	0	0	0	Receiver channel status bit
1	0	0	1	Receiver user data bit
1	0	1	0	Receiver block start clock
1	0	1	1	Receiver COPY bit (0 = copyright asserted, 1 = copyright not asserted)
1	1	0	0	Receiver L-bit (0 = first generation or higher, 1 = original)
1	1	0	1	Receiver parity error, active high
1	1	1	0	Receiver internal sync clock
1	1	1	1	Transmitter internal sync clock

**Registers 1F through 28: Q-Channel Sub-Code Data Registers**

Registers 0x1F through 0x28 comprise the Q-channel sub-code buffer, which may be accessed for audio CD playback. The Q-channel data provides information regarding the playback status for the current disc. The buffer data is decoded by the DIR block.

**Register 1F: Q-Channel Sub-Code Data Register 1 (Read-Only), Bits[7:0], Control and Address**

Bit 7 (MSB)	Bit 6	Bit 5	Bit 4	Bit 3	Bit 2	Bit 1	Bit 0 (LSB)
Q0	Q1	Q2	Q3	Q4	Q5	Q6	Q7

**Register 20: Q-Channel Sub-Code Data Register 2 (Read-Only), Bits[15:8], Track**

Bit 7 (MSB)	Bit 6	Bit 5	Bit 4	Bit 3	Bit 2	Bit 1	Bit 0 (LSB)
Q8	Q9	Q10	Q11	Q12	Q13	Q14	Q15

**Register 21: Q-Channel Sub-Code Data Register 3 (Read-Only), Bits[23:16], Index**

Bit 7 (MSB)	Bit 6	Bit 5	Bit 4	Bit 3	Bit 2	Bit 1	Bit 0 (LSB)
Q16	Q17	Q18	Q19	Q20	Q21	Q22	Q23

**Register 22: Q-Channel Sub-Code Data Register 4 (Read-Only), Bits[31:24], Minutes**

Bit 7 (MSB)	Bit 6	Bit 5	Bit 4	Bit 3	Bit 2	Bit 1	Bit 0 (LSB)
Q24	Q25	Q26	Q27	Q28	Q29	Q30	Q31

**Register 23: : Q-Channel Sub-Code Data Register 5 (Read-Only), Bits[39:32], Seconds**

Bit 7 (MSB)	Bit 6	Bit 5	Bit 4	Bit 3	Bit 2	Bit 1	Bit 0 (LSB)
Q32	Q33	Q34	Q35	Q36	Q37	Q38	Q39

**Register 24: : Q-Channel Sub-Code Data Register 6 (Read-Only), Bits[47:40], Frame**

Bit 7 (MSB)	Bit 6	Bit 5	Bit 4	Bit 3	Bit 2	Bit 1	Bit 0 (LSB)
Q40	Q41	Q42	Q43	Q44	Q45	Q46	Q47

**Register 25: Q-Channel Sub-Code Data Register 7 (Read-Only), Bits[55:48], Zero**

Bit 7 (MSB)	Bit 6	Bit 5	Bit 4	Bit 3	Bit 2	Bit 1	Bit 0 (LSB)
Q48	Q49	Q50	Q51	Q52	Q53	Q54	Q55

**Register 26: Q-Channel Sub-Code Data Register 8 (Read-Only), Bits[63:56], AMIN**

Bit 7 (MSB)	Bit 6	Bit 5	Bit 4	Bit 3	Bit 2	Bit 1	Bit 0 (LSB)
Q56	Q57	Q58	Q59	Q60	Q61	Q62	Q63

**Register 27: Q-Channel Sub-Code Data Register 9 (Read-Only), Bits[71:64], ASEC**

Bit 7 (MSB)	Bit 6	Bit 5	Bit 4	Bit 3	Bit 2	Bit 1	Bit 0 (LSB)
Q64	Q65	Q66	Q67	Q68	Q69	Q70	Q71

**Register 28: Q-Channel Sub-Code Data Register 10 (Read-Only), Bits[79:72], AFRAME**

Bit 7 (MSB)	Bit 6	Bit 5	Bit 4	Bit 3	Bit 2	Bit 1	Bit 0 (LSB)
Q72	Q73	Q74	Q75	Q76	Q77	Q78	Q79

**Registers 29 through 2C: IEC61937 PC/PD Burst Preamble**

The PC and PD burst preambles are part of the IEC61937 standard for transmission of data reduced, non-PCM audio over a standard two-channel interface (IEC60958). Examples of data-reduced formats include Dolby AC-3, DTS, various flavors of MPEG audio (including AAC), and Sony ATRAC. The PA and PB preambles provide synchronization data, and are fixed values of 0xF872 and 0x4E1F, respectively. The PC preamble indicates the type of data being carried by the interface and the PD preamble indicates the length of the burst, given as number of bits. Registers 0x29 through 0x2C contain the PC and PD preambles as decoded by the DIR block.

**Register 29: Burst Preamble PC High-Byte Status Register (Read-Only)**

Bit 7 (MSB)	Bit 6	Bit 5	Bit 4	Bit 3	Bit 2	Bit 1	Bit 0 (LSB)
PC15	PC14	PC13	PC12	PC11	PC10	PC09	PC08

**Register 2A: Burst Preamble PC Low-Byte Status Register (Read-Only)**

Bit 7 (MSB)	Bit 6	Bit 5	Bit 4	Bit 3	Bit 2	Bit 1	Bit 0 (LSB)
PC07	PC06	PC05	PC04	PC03	PC02	PC01	PC00

PC[4:0], Hex	Data Type
00	Null
01	Dolby AC-3
02	Reserved
03	Pause
04	MPEG-1 layer 1
05	MPEG-1 layer 2 or 3, or MPEG-2 without extension
06	MPEG-2 Data with extension
07	MPEG-2 AAC ADTS
08	MPEG-2 layer 1 low sample rate
09	MPEG-2 layer 2 or 3 low sample rate
0A	Reserved
0B	DTS type 1
0C	DTS type 2
0D	DTS type 3
0E	ATRAC
0F	ATRAC2/3
10-1F	Reserved

Bits PC[6:5] are both set to 0.

Bit PC[7] is an Error Flag, where: 0 = A valid burst-payload; 1 = Burst-payload may contain errors.

Bits PC[12:8] are data-type dependent.

Bits PC[15:13] indicate the stream number, which is set to 0.

**Register 2B: Burst Preamble PD High-Byte Status Register (Read-Only)**

Bit 7 (MSB)	Bit 6	Bit 5	Bit 4	Bit 3	Bit 2	Bit 1	Bit 0 (LSB)
PD15	PD14	PD13	PD12	PD11	PD10	PD09	PD08

**Register 2C: Burst Preamble PD Low-Byte Status Register (Read-Only)**

Bit 7 (MSB)	Bit 6	Bit 5	Bit 4	Bit 3	Bit 2	Bit 1	Bit 0 (LSB)
PD07	PD06	PD05	PD04	PD03	PD02	PD01	PD00

**Register 7F: Page Selection Register**

Bit 7 (MSB)	Bit 6	Bit 5	Bit 4	Bit 3	Bit 2	Bit 1	Bit 0 (LSB)
0	0	0	0	0	0	PAGE1	PAGE0

**PAGE[1:0] Page Selection**

These bits are utilized to select one of three register pages for write and/or read access via the SPI or I<sup>2</sup>C serial host interface. The Page Selection Register is present on every register page at address 0x7F, allowing movement between pages as necessary.

PAGE1	PAGE0	Register/Buffer Page Selection
0	0	Page 0, control and status registers (default)
0	1	Page 1, DIR channel status and user data buffers
1	0	Page 2, DIT channel status and user data buffers
1	1	Page 3, reserved

**CHANNEL STATUS AND USER DATA BUFFER MAPS**

Table 5 through Table 8 show the buffer maps for the DIR and DIT channel status and user data buffers.

For Table 5, the channel status byte definitions are dependent on the transmission mode, either Professional or Consumer. Bit 0 of Byte 0 defines the transmission mode, 0 for Consumer mode, and 1 for Professional mode. This is applicable for Table 5 and Table 6.

For Table 7, the channel status byte definitions are dependent on the transmission mode, either Professional or Consumer. Bit 0 of Byte 0 defines the transmission mode, 0 for Consumer mode, and 1 for Professional mode. In Professional mode, Byte 23 for each channel is reserved for CRC data, which is automatically calculated and encoded by the DIT. There is no need to program Byte 23 for either channel in Professional mode.

**CHANNEL STATUS AND USER DATA BUFFER MAPS (continued)**
**Table 5. DIR Channel Status Data Buffer Map (Register Page 1)**

ADDRESS (Hex)	CHANNEL	BYTE	BIT 0 (MSB)	BIT 1	BIT 2	BIT 3	BIT 4	BIT 5	BIT 6	BIT 7
0	1	0	D0	D1	D2	D3	D4	D5	D6	D7
1	2	0	D0	D1	D2	D3	D4	D5	D6	D7
2	1	1	D0	D1	D2	D3	D4	D5	D6	D7
3	2	1	D0	D1	D2	D3	D4	D5	D6	D7
4	1	2	D0	D1	D2	D3	D4	D5	D6	D7
5	2	2	D0	D1	D2	D3	D4	D5	D6	D7
6	1	3	D0	D1	D2	D3	D4	D5	D6	D7
7	2	3	D0	D1	D2	D3	D4	D5	D6	D7
8	1	4	D0	D1	D2	D3	D4	D5	D6	D7
9	2	4	D0	D1	D2	D3	D4	D5	D6	D7
A	1	5	D0	D1	D2	D3	D4	D5	D6	D7
B	2	5	D0	D1	D2	D3	D4	D5	D6	D7
C	1	6	D0	D1	D2	D3	D4	D5	D6	D7
D	2	6	D0	D1	D2	D3	D4	D5	D6	D7
E	1	7	D0	D1	D2	D3	D4	D5	D6	D7
F	2	7	D0	D1	D2	D3	D4	D5	D6	D7
10	1	8	D0	D1	D2	D3	D4	D5	D6	D7
11	2	8	D0	D1	D2	D3	D4	D5	D6	D7
12	1	9	D0	D1	D2	D3	D4	D5	D6	D7
13	2	9	D0	D1	D2	D3	D4	D5	D6	D7
14	1	10	D0	D1	D2	D3	D4	D5	D6	D7
15	2	10	D0	D1	D2	D3	D4	D5	D6	D7
16	1	11	D0	D1	D2	D3	D4	D5	D6	D7
17	2	11	D0	D1	D2	D3	D4	D5	D6	D7
18	1	12	D0	D1	D2	D3	D4	D5	D6	D7
19	2	12	D0	D1	D2	D3	D4	D5	D6	D7
1A	1	13	D0	D1	D2	D3	D4	D5	D6	D7
1B	2	13	D0	D1	D2	D3	D4	D5	D6	D7
1C	1	14	D0	D1	D2	D3	D4	D5	D6	D7
1D	2	14	D0	D1	D2	D3	D4	D5	D6	D7
1E	1	15	D0	D1	D2	D3	D4	D5	D6	D7
1F	2	15	D0	D1	D2	D3	D4	D5	D6	D7
20	1	16	D0	D1	D2	D3	D4	D5	D6	D7
21	2	16	D0	D1	D2	D3	D4	D5	D6	D7
22	1	17	D0	D1	D2	D3	D4	D5	D6	D7
23	2	17	D0	D1	D2	D3	D4	D5	D6	D7
24	1	18	D0	D1	D2	D3	D4	D5	D6	D7
25	2	18	D0	D1	D2	D3	D4	D5	D6	D7
26	1	19	D0	D1	D2	D3	D4	D5	D6	D7
27	2	19	D0	D1	D2	D3	D4	D5	D6	D7
28	1	20	D0	D1	D2	D3	D4	D5	D6	D7
29	2	20	D0	D1	D2	D3	D4	D5	D6	D7
2A	1	21	D0	D1	D2	D3	D4	D5	D6	D7
2B	2	21	D0	D1	D2	D3	D4	D5	D6	D7
2C	1	22	D0	D1	D2	D3	D4	D5	D6	D7
2D	2	22	D0	D1	D2	D3	D4	D5	D6	D7
2E	1	23	D0	D1	D2	D3	D4	D5	D6	D7
2F	2	23	D0	D1	D2	D3	D4	D5	D6	D7

**Table 6. DIR User Data Buffer Map (Register Page 1)**

ADDRESS (Hex)	CHANNEL	BYTE	BIT 0 (MSB)	BIT 1	BIT 2	BIT 3	BIT 4	BIT 5	BIT 6	BIT 7
40	1	0	D0	D1	D2	D3	D4	D5	D6	D7
41	2	0	D0	D1	D2	D3	D4	D5	D6	D7
42	1	1	D0	D1	D2	D3	D4	D5	D6	D7
43	2	1	D0	D1	D2	D3	D4	D5	D6	D7
44	1	2	D0	D1	D2	D3	D4	D5	D6	D7
45	2	2	D0	D1	D2	D3	D4	D5	D6	D7
46	1	3	D0	D1	D2	D3	D4	D5	D6	D7
47	2	3	D0	D1	D2	D3	D4	D5	D6	D7
48	1	4	D0	D1	D2	D3	D4	D5	D6	D7
49	2	4	D0	D1	D2	D3	D4	D5	D6	D7
4A	1	5	D0	D1	D2	D3	D4	D5	D6	D7
4B	2	5	D0	D1	D2	D3	D4	D5	D6	D7
4C	1	6	D0	D1	D2	D3	D4	D5	D6	D7
4D	2	6	D0	D1	D2	D3	D4	D5	D6	D7
4E	1	7	D0	D1	D2	D3	D4	D5	D6	D7
4F	2	7	D0	D1	D2	D3	D4	D5	D6	D7
50	1	8	D0	D1	D2	D3	D4	D5	D6	D7
51	2	8	D0	D1	D2	D3	D4	D5	D6	D7
52	1	9	D0	D1	D2	D3	D4	D5	D6	D7
53	2	9	D0	D1	D2	D3	D4	D5	D6	D7
54	1	10	D0	D1	D2	D3	D4	D5	D6	D7
55	2	10	D0	D1	D2	D3	D4	D5	D6	D7
56	1	11	D0	D1	D2	D3	D4	D5	D6	D7
57	2	11	D0	D1	D2	D3	D4	D5	D6	D7
58	1	12	D0	D1	D2	D3	D4	D5	D6	D7
59	2	12	D0	D1	D2	D3	D4	D5	D6	D7
5A	1	13	D0	D1	D2	D3	D4	D5	D6	D7
5B	2	13	D0	D1	D2	D3	D4	D5	D6	D7
5C	1	14	D0	D1	D2	D3	D4	D5	D6	D7
5D	2	14	D0	D1	D2	D3	D4	D5	D6	D7
5E	1	15	D0	D1	D2	D3	D4	D5	D6	D7
5F	2	15	D0	D1	D2	D3	D4	D5	D6	D7
60	1	16	D0	D1	D2	D3	D4	D5	D6	D7
61	2	16	D0	D1	D2	D3	D4	D5	D6	D7
62	1	17	D0	D1	D2	D3	D4	D5	D6	D7
63	2	17	D0	D1	D2	D3	D4	D5	D6	D7
64	1	18	D0	D1	D2	D3	D4	D5	D6	D7
65	2	18	D0	D1	D2	D3	D4	D5	D6	D7
66	1	19	D0	D1	D2	D3	D4	D5	D6	D7
67	2	19	D0	D1	D2	D3	D4	D5	D6	D7
68	1	20	D0	D1	D2	D3	D4	D5	D6	D7
69	2	20	D0	D1	D2	D3	D4	D5	D6	D7
6A	1	21	D0	D1	D2	D3	D4	D5	D6	D7
6B	2	21	D0	D1	D2	D3	D4	D5	D6	D7
6C	1	22	D0	D1	D2	D3	D4	D5	D6	D7
6D	2	22	D0	D1	D2	D3	D4	D5	D6	D7
6E	1	23	D0	D1	D2	D3	D4	D5	D6	D7
6F	2	23	D0	D1	D2	D3	D4	D5	D6	D7

**Table 7. DIT Channel Status Data Buffer Map (Register Page 2)**

ADDRESS (Hex)	CHANNEL	BYTE	BIT 0 (MSB)	BIT 1	BIT 2	BIT 3	BIT 4	BIT 5	BIT 6	BIT 7
0	1	0	D0	D1	D2	D3	D4	D5	D6	D7
1	2	0	D0	D1	D2	D3	D4	D5	D6	D7
2	1	1	D0	D1	D2	D3	D4	D5	D6	D7
3	2	1	D0	D1	D2	D3	D4	D5	D6	D7
4	1	2	D0	D1	D2	D3	D4	D5	D6	D7
5	2	2	D0	D1	D2	D3	D4	D5	D6	D7
6	1	3	D0	D1	D2	D3	D4	D5	D6	D7
7	2	3	D0	D1	D2	D3	D4	D5	D6	D7
8	1	4	D0	D1	D2	D3	D4	D5	D6	D7
9	2	4	D0	D1	D2	D3	D4	D5	D6	D7
A	1	5	D0	D1	D2	D3	D4	D5	D6	D7
B	2	5	D0	D1	D2	D3	D4	D5	D6	D7
C	1	6	D0	D1	D2	D3	D4	D5	D6	D7
D	2	6	D0	D1	D2	D3	D4	D5	D6	D7
E	1	7	D0	D1	D2	D3	D4	D5	D6	D7
F	2	7	D0	D1	D2	D3	D4	D5	D6	D7
10	1	8	D0	D1	D2	D3	D4	D5	D6	D7
11	2	8	D0	D1	D2	D3	D4	D5	D6	D7
12	1	9	D0	D1	D2	D3	D4	D5	D6	D7
13	2	9	D0	D1	D2	D3	D4	D5	D6	D7
14	1	10	D0	D1	D2	D3	D4	D5	D6	D7
15	2	10	D0	D1	D2	D3	D4	D5	D6	D7
16	1	11	D0	D1	D2	D3	D4	D5	D6	D7
17	2	11	D0	D1	D2	D3	D4	D5	D6	D7
18	1	12	D0	D1	D2	D3	D4	D5	D6	D7
19	2	12	D0	D1	D2	D3	D4	D5	D6	D7
1A	1	13	D0	D1	D2	D3	D4	D5	D6	D7
1B	2	13	D0	D1	D2	D3	D4	D5	D6	D7
1C	1	14	D0	D1	D2	D3	D4	D5	D6	D7
1D	2	14	D0	D1	D2	D3	D4	D5	D6	D7
1E	1	15	D0	D1	D2	D3	D4	D5	D6	D7
1F	2	15	D0	D1	D2	D3	D4	D5	D6	D7
20	1	16	D0	D1	D2	D3	D4	D5	D6	D7
21	2	16	D0	D1	D2	D3	D4	D5	D6	D7
22	1	17	D0	D1	D2	D3	D4	D5	D6	D7
23	2	17	D0	D1	D2	D3	D4	D5	D6	D7
24	1	18	D0	D1	D2	D3	D4	D5	D6	D7
25	2	18	D0	D1	D2	D3	D4	D5	D6	D7
26	1	19	D0	D1	D2	D3	D4	D5	D6	D7
27	2	19	D0	D1	D2	D3	D4	D5	D6	D7
28	1	20	D0	D1	D2	D3	D4	D5	D6	D7
29	2	20	D0	D1	D2	D3	D4	D5	D6	D7
2A	1	21	D0	D1	D2	D3	D4	D5	D6	D7
2B	2	21	D0	D1	D2	D3	D4	D5	D6	D7
2C	1	22	D0	D1	D2	D3	D4	D5	D6	D7
2D	2	22	D0	D1	D2	D3	D4	D5	D6	D7
2E	1	23	D0	D1	D2	D3	D4	D5	D6	D7
2F	2	23	D0	D1	D2	D3	D4	D5	D6	D7

**Table 8. DIT User Data Buffer Map (Register Page 2)**

ADDRESS (Hex)	CHANNEL	BYTE	BIT 0 (MSB)	BIT 1	BIT 2	BIT 3	BIT 4	BIT 5	BIT 6	BIT 7
40	1	0	D0	D1	D2	D3	D4	D5	D6	D7
41	2	0	D0	D1	D2	D3	D4	D5	D6	D7
42	1	1	D0	D1	D2	D3	D4	D5	D6	D7
43	2	1	D0	D1	D2	D3	D4	D5	D6	D7
44	1	2	D0	D1	D2	D3	D4	D5	D6	D7
45	2	2	D0	D1	D2	D3	D4	D5	D6	D7
46	1	3	D0	D1	D2	D3	D4	D5	D6	D7
47	2	3	D0	D1	D2	D3	D4	D5	D6	D7
48	1	4	D0	D1	D2	D3	D4	D5	D6	D7
49	2	4	D0	D1	D2	D3	D4	D5	D6	D7
4A	1	5	D0	D1	D2	D3	D4	D5	D6	D7
4B	2	5	D0	D1	D2	D3	D4	D5	D6	D7
4C	1	6	D0	D1	D2	D3	D4	D5	D6	D7
4D	2	6	D0	D1	D2	D3	D4	D5	D6	D7
4E	1	7	D0	D1	D2	D3	D4	D5	D6	D7
4F	2	7	D0	D1	D2	D3	D4	D5	D6	D7
50	1	8	D0	D1	D2	D3	D4	D5	D6	D7
51	2	8	D0	D1	D2	D3	D4	D5	D6	D7
52	1	9	D0	D1	D2	D3	D4	D5	D6	D7
53	2	9	D0	D1	D2	D3	D4	D5	D6	D7
54	1	10	D0	D1	D2	D3	D4	D5	D6	D7
55	2	10	D0	D1	D2	D3	D4	D5	D6	D7
56	1	11	D0	D1	D2	D3	D4	D5	D6	D7
57	2	11	D0	D1	D2	D3	D4	D5	D6	D7
58	1	12	D0	D1	D2	D3	D4	D5	D6	D7
59	2	12	D0	D1	D2	D3	D4	D5	D6	D7
5A	1	13	D0	D1	D2	D3	D4	D5	D6	D7
5B	2	13	D0	D1	D2	D3	D4	D5	D6	D7
5C	1	14	D0	D1	D2	D3	D4	D5	D6	D7
5D	2	14	D0	D1	D2	D3	D4	D5	D6	D7
5E	1	15	D0	D1	D2	D3	D4	D5	D6	D7
5F	2	15	D0	D1	D2	D3	D4	D5	D6	D7
60	1	16	D0	D1	D2	D3	D4	D5	D6	D7
61	2	16	D0	D1	D2	D3	D4	D5	D6	D7
62	1	17	D0	D1	D2	D3	D4	D5	D6	D7
63	2	17	D0	D1	D2	D3	D4	D5	D6	D7
64	1	18	D0	D1	D2	D3	D4	D5	D6	D7
65	2	18	D0	D1	D2	D3	D4	D5	D6	D7
66	1	19	D0	D1	D2	D3	D4	D5	D6	D7
67	2	19	D0	D1	D2	D3	D4	D5	D6	D7
68	1	20	D0	D1	D2	D3	D4	D5	D6	D7
69	2	20	D0	D1	D2	D3	D4	D5	D6	D7
6A	1	21	D0	D1	D2	D3	D4	D5	D6	D7
6B	2	21	D0	D1	D2	D3	D4	D5	D6	D7
6C	1	22	D0	D1	D2	D3	D4	D5	D6	D7
6D	2	22	D0	D1	D2	D3	D4	D5	D6	D7
6E	1	23	D0	D1	D2	D3	D4	D5	D6	D7
6F	2	23	D0	D1	D2	D3	D4	D5	D6	D7



## REFERENCE DOCUMENTS

Throughout this data sheet, various standards and documents are repeatedly cited as references. Sources for these documents are listed here so that the reader may obtain the documents for further study.

Audio Engineering Society (AES) standards documents, including the AES3, AES11, AES18, and related specifications are available from the AES web site: <http://www.aes.org>.

International Electrotechnical Committee (IEC) standards, including the IEC60958 and IEC61937 are available from the IEC web site: <http://www.iec.ch>; or the ANSI web site: <http://www.ansi.org>.

The EIAJ CP-1212 (formerly CP-1201) standard is available from the Japanese Electronics and Information Technologies Industries Association (JEITA): <http://www.jeita.or.jp/english>.

The Philips I<sup>2</sup>C bus specification is available from Philips: <http://www.philips.com>. The version utilized as a reference for this product is Version 2.1, published in January 2000.

Several papers regarding balanced and unbalanced transformer-coupled digital audio interfaces have been published and presented at past AES conventions by Jon D. Paul of Scientific Conversion, Inc. These papers are available for download from: <http://www.scientificconversion.com>.

**PACKAGING INFORMATION**

Orderable Device	Status <sup>(1)</sup>	Package Type	Package Drawing	Pins	Package Qty	Eco Plan <sup>(2)</sup>	Lead/Ball Finish	MSL Peak Temp <sup>(3)</sup>
DIX4192IPFB	ACTIVE	TQFP	PFB	48	250	Green (RoHS & no Sb/Br)	CU NIPDAU	Level-2-260C-1 YEAR
DIX4192IPFBG4	ACTIVE	TQFP	PFB	48	250	Green (RoHS & no Sb/Br)	CU NIPDAU	Level-2-260C-1 YEAR
DIX4192IPFBR	ACTIVE	TQFP	PFB	48	1000	Green (RoHS & no Sb/Br)	CU NIPDAU	Level-2-260C-1 YEAR
DIX4192IPFBRG4	ACTIVE	TQFP	PFB	48	1000	Green (RoHS & no Sb/Br)	CU NIPDAU	Level-2-260C-1 YEAR

<sup>(1)</sup> The marketing status values are defined as follows:

**ACTIVE:** Product device recommended for new designs.

**LIFEBUY:** TI has announced that the device will be discontinued, and a lifetime-buy period is in effect.

**NRND:** Not recommended for new designs. Device is in production to support existing customers, but TI does not recommend using this part in a new design.

**PREVIEW:** Device has been announced but is not in production. Samples may or may not be available.

**OBSOLETE:** TI has discontinued the production of the device.

<sup>(2)</sup> Eco Plan - The planned eco-friendly classification: Pb-Free (RoHS), Pb-Free (RoHS Exempt), or Green (RoHS & no Sb/Br) - please check <http://www.ti.com/productcontent> for the latest availability information and additional product content details.

**TBD:** The Pb-Free/Green conversion plan has not been defined.

**Pb-Free (RoHS):** TI's terms "Lead-Free" or "Pb-Free" mean semiconductor products that are compatible with the current RoHS requirements for all 6 substances, including the requirement that lead not exceed 0.1% by weight in homogeneous materials. Where designed to be soldered at high temperatures, TI Pb-Free products are suitable for use in specified lead-free processes.

**Pb-Free (RoHS Exempt):** This component has a RoHS exemption for either 1) lead-based flip-chip solder bumps used between the die and package, or 2) lead-based die adhesive used between the die and leadframe. The component is otherwise considered Pb-Free (RoHS compatible) as defined above.

**Green (RoHS & no Sb/Br):** TI defines "Green" to mean Pb-Free (RoHS compatible), and free of Bromine (Br) and Antimony (Sb) based flame retardants (Br or Sb do not exceed 0.1% by weight in homogeneous material)

<sup>(3)</sup> MSL, Peak Temp. -- The Moisture Sensitivity Level rating according to the JEDEC industry standard classifications, and peak solder temperature.

**Important Information and Disclaimer:**The information provided on this page represents TI's knowledge and belief as of the date that it is provided. TI bases its knowledge and belief on information provided by third parties, and makes no representation or warranty as to the accuracy of such information. Efforts are underway to better integrate information from third parties. TI has taken and continues to take reasonable steps to provide representative and accurate information but may not have conducted destructive testing or chemical analysis on incoming materials and chemicals. TI and TI suppliers consider certain information to be proprietary, and thus CAS numbers and other limited information may not be available for release.

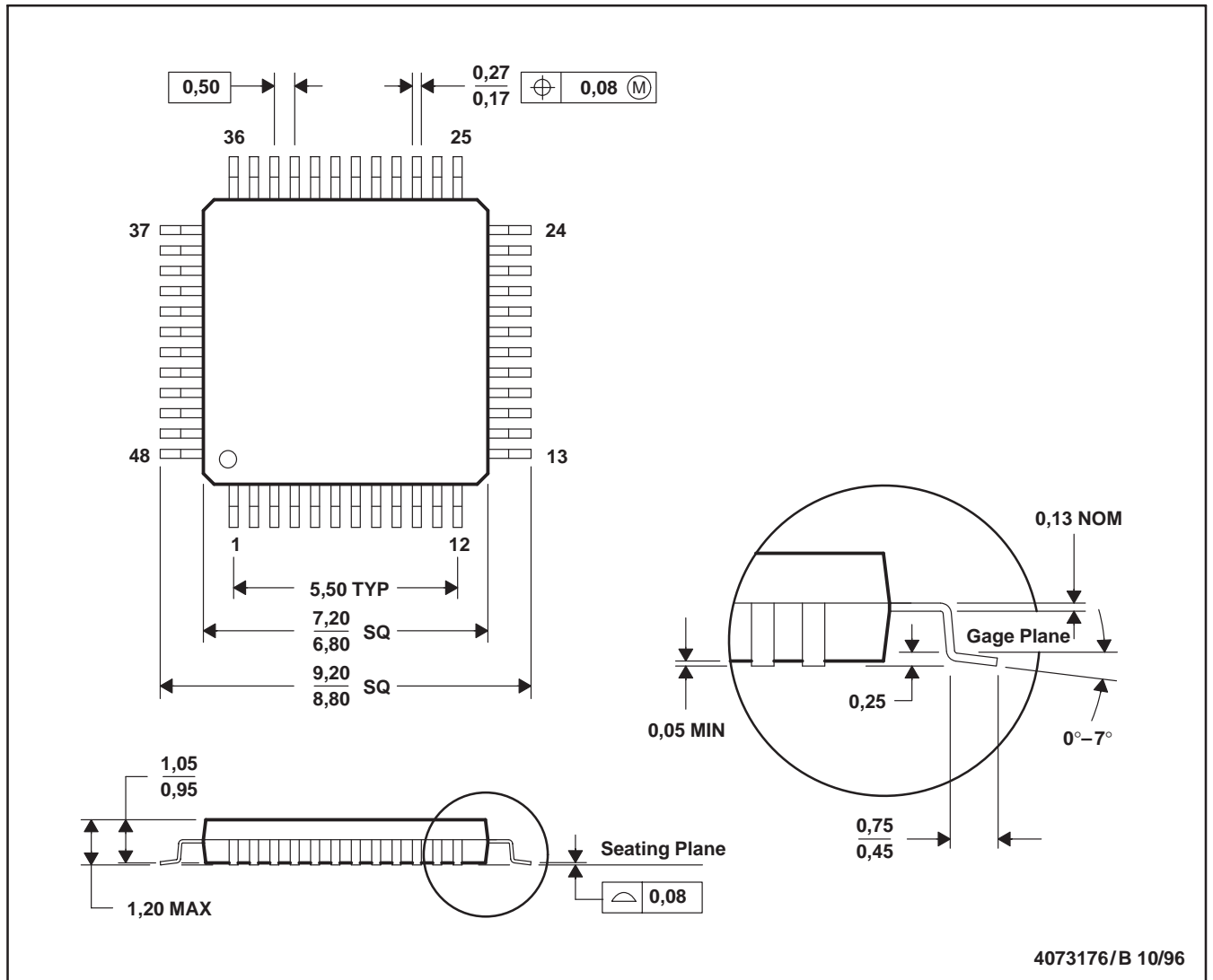
In no event shall TI's liability arising out of such information exceed the total purchase price of the TI part(s) at issue in this document sold by TI to Customer on an annual basis.

# MECHANICAL DATA

MTQF019A – JANUARY 1995 – REVISED JANUARY 1998

PFB (S-PQFP-G48)

PLASTIC QUAD FLATPACK



- NOTES: A. All linear dimensions are in millimeters.  
 B. This drawing is subject to change without notice.  
 C. Falls within JEDEC MS-026

## IMPORTANT NOTICE

Texas Instruments Incorporated and its subsidiaries (TI) reserve the right to make corrections, modifications, enhancements, improvements, and other changes to its products and services at any time and to discontinue any product or service without notice. Customers should obtain the latest relevant information before placing orders and should verify that such information is current and complete. All products are sold subject to TI's terms and conditions of sale supplied at the time of order acknowledgment.

TI warrants performance of its hardware products to the specifications applicable at the time of sale in accordance with TI's standard warranty. Testing and other quality control techniques are used to the extent TI deems necessary to support this warranty. Except where mandated by government requirements, testing of all parameters of each product is not necessarily performed.

TI assumes no liability for applications assistance or customer product design. Customers are responsible for their products and applications using TI components. To minimize the risks associated with customer products and applications, customers should provide adequate design and operating safeguards.

TI does not warrant or represent that any license, either express or implied, is granted under any TI patent right, copyright, mask work right, or other TI intellectual property right relating to any combination, machine, or process in which TI products or services are used. Information published by TI regarding third-party products or services does not constitute a license from TI to use such products or services or a warranty or endorsement thereof. Use of such information may require a license from a third party under the patents or other intellectual property of the third party, or a license from TI under the patents or other intellectual property of TI.

Reproduction of information in TI data books or data sheets is permissible only if reproduction is without alteration and is accompanied by all associated warranties, conditions, limitations, and notices. Reproduction of this information with alteration is an unfair and deceptive business practice. TI is not responsible or liable for such altered documentation.

Resale of TI products or services with statements different from or beyond the parameters stated by TI for that product or service voids all express and any implied warranties for the associated TI product or service and is an unfair and deceptive business practice. TI is not responsible or liable for any such statements.

Following are URLs where you can obtain information on other Texas Instruments products and application solutions:

<b>Products</b>		<b>Applications</b>	
Amplifiers	<a href="http://amplifier.ti.com">amplifier.ti.com</a>	Audio	<a href="http://www.ti.com/audio">www.ti.com/audio</a>
Data Converters	<a href="http://dataconverter.ti.com">dataconverter.ti.com</a>	Automotive	<a href="http://www.ti.com/automotive">www.ti.com/automotive</a>
DSP	<a href="http://dsp.ti.com">dsp.ti.com</a>	Broadband	<a href="http://www.ti.com/broadband">www.ti.com/broadband</a>
Interface	<a href="http://interface.ti.com">interface.ti.com</a>	Digital Control	<a href="http://www.ti.com/digitalcontrol">www.ti.com/digitalcontrol</a>
Logic	<a href="http://logic.ti.com">logic.ti.com</a>	Military	<a href="http://www.ti.com/military">www.ti.com/military</a>
Power Mgmt	<a href="http://power.ti.com">power.ti.com</a>	Optical Networking	<a href="http://www.ti.com/opticalnetwork">www.ti.com/opticalnetwork</a>
Microcontrollers	<a href="http://microcontroller.ti.com">microcontroller.ti.com</a>	Security	<a href="http://www.ti.com/security">www.ti.com/security</a>
Low Power Wireless	<a href="http://www.ti.com/lpw">www.ti.com/lpw</a>	Telephony	<a href="http://www.ti.com/telephony">www.ti.com/telephony</a>
		Video & Imaging	<a href="http://www.ti.com/video">www.ti.com/video</a>
		Wireless	<a href="http://www.ti.com/wireless">www.ti.com/wireless</a>

Mailing Address: Texas Instruments  
Post Office Box 655303 Dallas, Texas 75265