

HD66205

(Dot Matrix Liquid Crystal Graphic Display Common Driver with 80-Channel Outputs)

Description

The HD66205F/HD66205FL/HD66205TF/HD66205TFL/HD66205T/HD66205TL, the row LCD driver, features low output impedance and as many as 80 LCD outputs powered by 80 internal LCD drive circuits, and can drive a large liquid crystal graphic display. Because this device is fabricated by the CMOS process, it is suitable for battery-driven portable equipment, which fully utilizes the low power dissipation of liquid crystal elements. The HD66205 has a complete line-up: the HD66205F, a standard device powered by 5 V \pm 10%; the HD66205FL, a 2.7–5.5 V, low power dissipation device; the HD66205TF and HD66205TFL, thin film package devices each powered by 5 V \pm 10% and 2.7–5.5 V; and the

HD66205T, tape carrier package (TCP) devices powered by 2.7–5.5 V, respectively.

Features

- Duty cycle: 1/64 to 1/240
- High voltage
 - LCD drive: 10–28 V
- Display off function
- Internal 80-bit shift register
- Various LCD controller interfaces
 - LCTC series: HD63645, HD64645, HD64646
 - LVIC series: HD66840, HD66841
 - CLINE: HD66850

Ordering Information 1 (Flat package and die shipment)

Type No.	Voltage Range	Package
HD66205F	5 V ± 10%	100-pin plastic QFP (FP-100)
HD66205FL	2.7-5.5 V	100-pin plastic QFP (FP-100)
HD66205TF	5 V ± 10%	100-pin thin plastic QFP (TFP-100)
HD66205TFL	2.7-5.5 V	100-pin thin plastic QFP (TFP-100)
HCD66205	5 V ± 10%	Chip
HCD66205L	2.7-5.5 V	Chip

Ordering Information 2 (tape carrier package)

Type No.	Voltage Range	Outer Lead Pitch 1	Outer Lead Pitch 2	Device Length
HD66205TA1	2.7-5.5V	0.15mm	0.80mm	4 sprocket holes
HD66205TA2	2.7-5.5V	0.18mm	0.80mm	4 sprocket holes
HD66205TA3	2.7-5.5V	0.20mm	0.80mm	4 sprocket holes
HD66205TA6	2.7-5.5V	0.22mm	0.70mm	4 sprocket holes
HD66205TA7	2.7-5.5V	0.25mm	0.70mm	4 sprocket holes
HD66205TA9L	2.7-5.5V	0.22mm	0.70mm	3 sprocket holes

- Notes:
1. Outer lead pitch 1 is for LCD drive output pins, and outer lead pitch 2 for the other pins.
 2. Device length includes test pad areas.
 3. Spacing between two sprocket holes is 4.75mm.
 4. Tape film is Upirex (a trademark of Ube industries, Ltd.).
 5. 35-mm-wide tape is used.
 6. Leads are plated with Sn.
 7. The details of TCP pattern are shown in " The Information of TCP. "

HD66205

Pin Arrangement

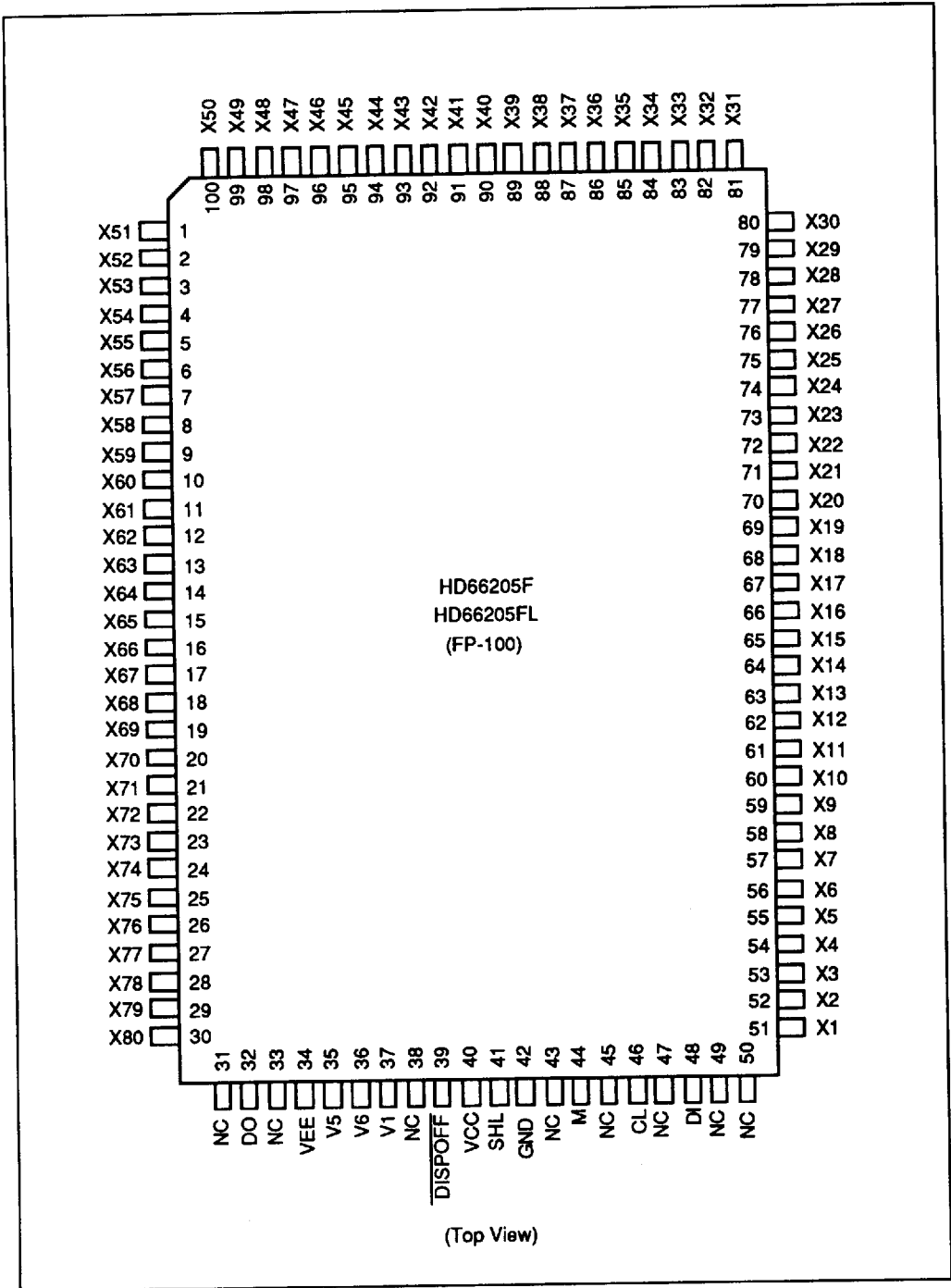

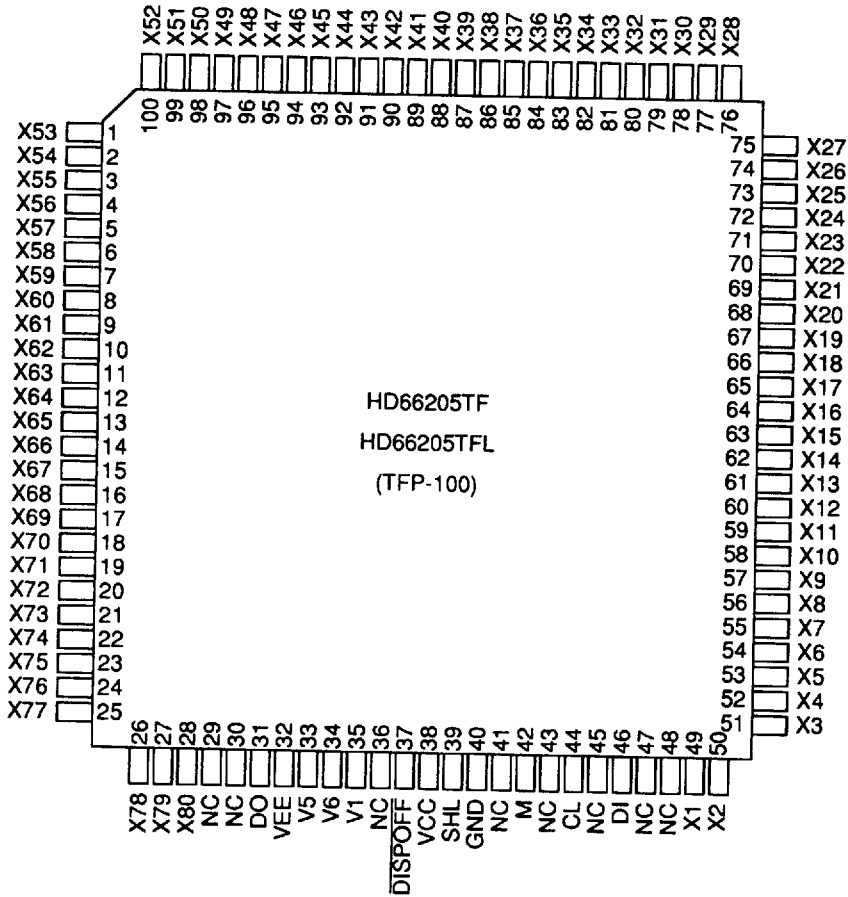

(Top View)

HD66205

Pin Description

Symbol	Pin No. (FP-100 / TFP-100)	Pin Name	Input/Output	Classification
V _{CC}	40/38	V _{CC}	—	Power supply
GND	42/40	GND	—	Power supply
V _{EE}	34/32	V _{EE}	—	Power supply
V1	37/35	V1	Input	Power supply
V5	35/33	V5	Input	Power supply
V6	36/34	V6	Input	Power supply
CL	46/44	Clock	Input	Control signal
M	44/42	M	Input	Control signal
DI	48/46	Data in	Input	Control signal
DO	32/31	Data out	Output	Control signal
SHL	41/39	Shift left	Input	Control signal
DISPOFF	39/37	Display off	Input	Control signal
X ₁ -X ₈₀	51-100, 1-30/ 1-28, 49-100	X1-X80	Output	LCD drive output
NC	31, 33, 38, 43, 45, 47, 49, 50/ 29, 30, 36, 41, 43, 45, 47, 48	No connection	—	—

Pin Functions**Power Supply**

V_{CC}, V_{EE}, GND: V_{CC}-GND supplies power to the internal logic circuits. V_{CC}-V_{EE} supplies power to the LCD drive circuits.

V1, V5, V6: Supply different levels of power to drive the LCD. V1 and V_{EE} are selected levels, and V5 and V6 are non-selected levels. See figure 1.

Control Signal

CL: Inputs data shift clock pulses for the shift register. At the falling edge of each CL pulse, the shift register shifts display data input via the DI pin.

M: Changes LCD drive outputs to AC.

DI: Inputs display data. DI of the first HD66205 must be connected to an LCD controller, and those of the other HD66205s must be connected to DI of the previous HD66205.

DO: Outputs display data. DO of the last HD66205 must be open, and those of the other HD66205s must be connected to DI of the next HD66205.

SHL: Selects the data shift direction for the shift register. See figure 2.

DISPOFF: A low $\overline{\text{DISP}}$ sets LCD drive outputs X₁-X₈₀ to V1 level.

LCD Drive Output

X₁-X₈₀: Each X outputs one of the four voltage levels V1, V5, V6, or V_{EE}, depending on a combination of the M signal and display data levels. See figure 3.

Other

NC: Must be open.

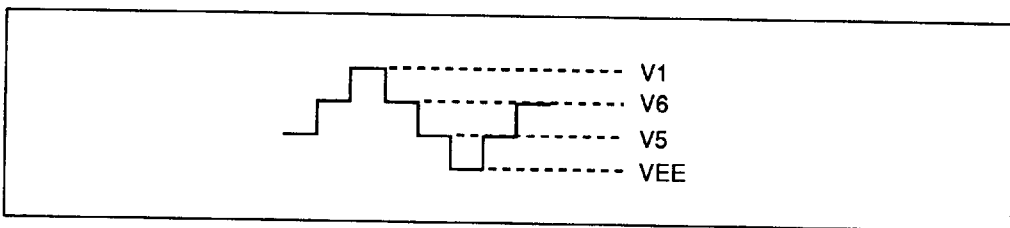

Figure 1 Different Power Supply Voltage Levels for LCD Drive Circuits

HD66205

SHL level	Data shift direction	Common signal scan direction
Low	DI → SR1 → SR2 → SR80	X1 → X80
High	DI → SR80 → SR79 → SR1	X80 → X1

Figure 2 Selection of Display Data Shift Direction

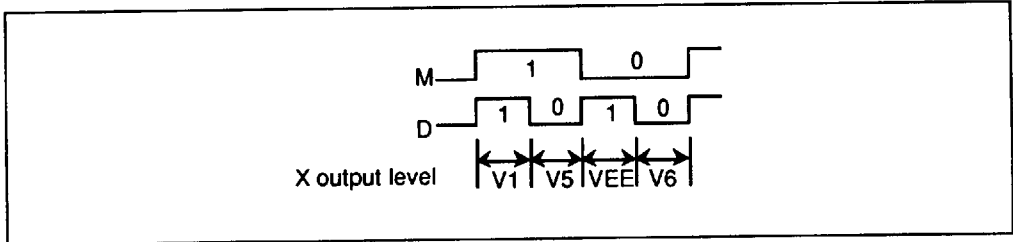

Figure 3 Selection of LCD Drive Output Level

Block Functions

LCD Drive Circuit

The 80-bit LCD drive circuit generates four voltage levels V1, V5, V6, and V_{EE}, for driving an LCD panel. One of the four levels is output to the corresponding Y pin, depending on a combination of the M signal and the data in the shift register

Level Shifter

The level shifter changes 5-V signals into high-voltage signals for the LCD drive circuit.

Shift Register

The 80-bit shift register shifts data input via the DI pin by one bit, and the one bit of shifted-out data is output from the DO pin. Both actions occur simultaneously at the falling edge of each shift clock (CL) pulse

Block Diagram

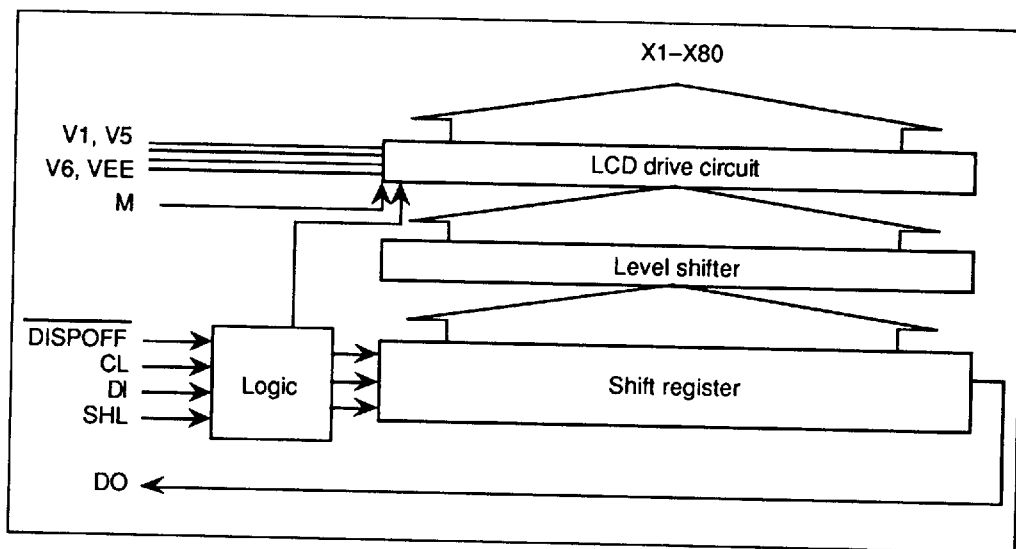

HD66205

Comparison of the HD66205 with the HD61105

Item	HD66205	HD61105
Display off function	Provided	Not provided
LCD drive voltage range	10–28 V	10–26 V
Shift clock phase selection function	Not provided	Provided (FCS pin)
Relation between SHL and LCD output destinations	See figure 4	See figure 4
Relation between LCD output levels, M, and data	See figure 5	See figure 5
LCD drive V pins	V1, V5, V6 (V2 level is the same as V _{EE} level)	V1, V2, V5, V6

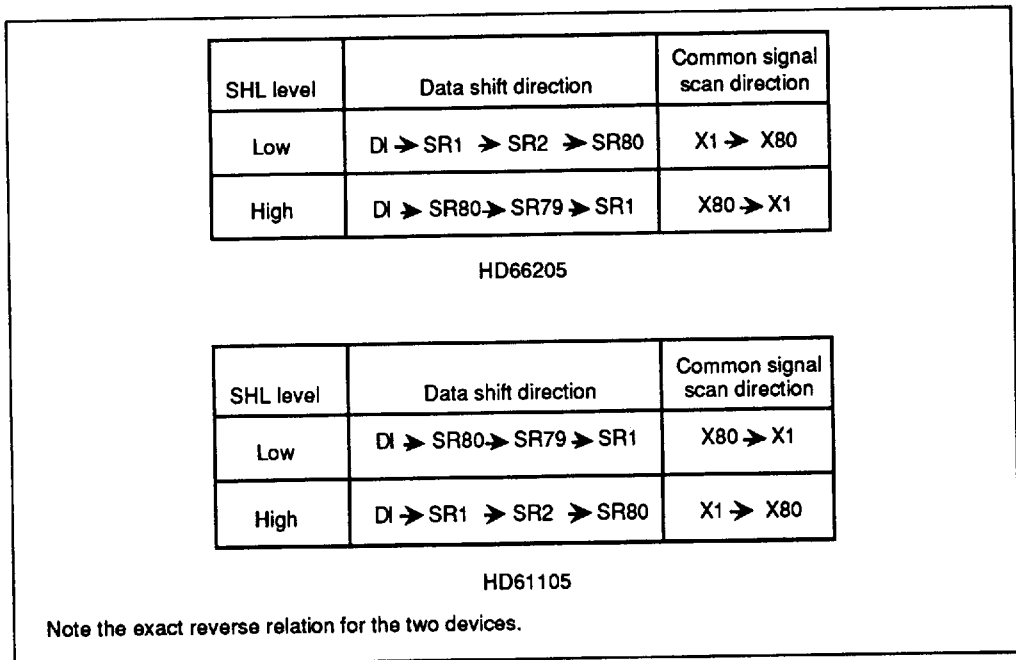

Figure 4 Relation between SHL and LCD Output Destinations for the HD66205 and HD61105

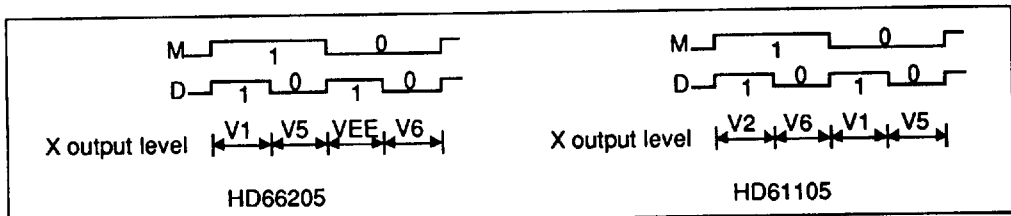

Figure 5 Relation between LCD Output Levels, M, and Data for the HD66205 and HD61105

Operation Timing

Figure 6 shows the operation timing for the Application Example.

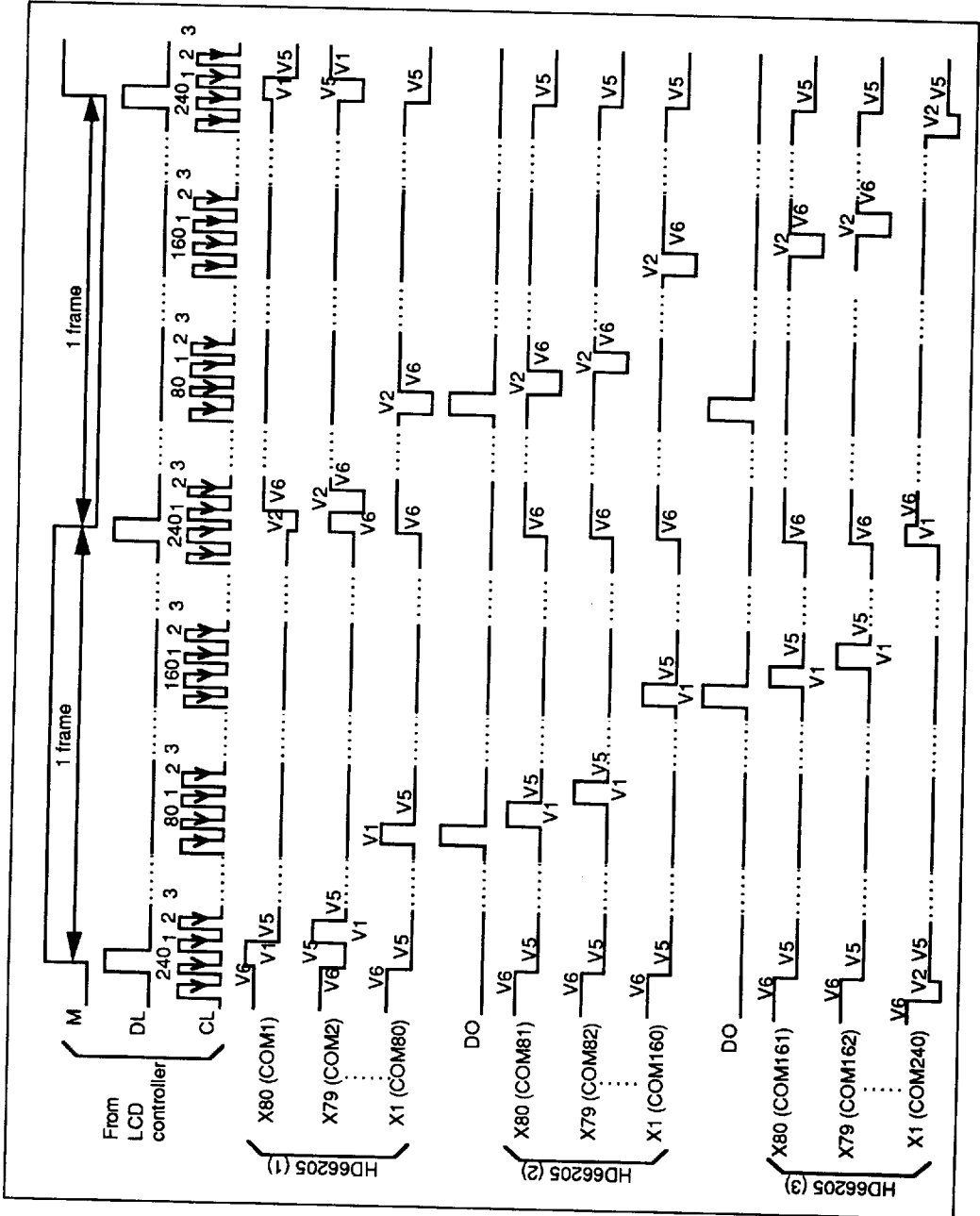
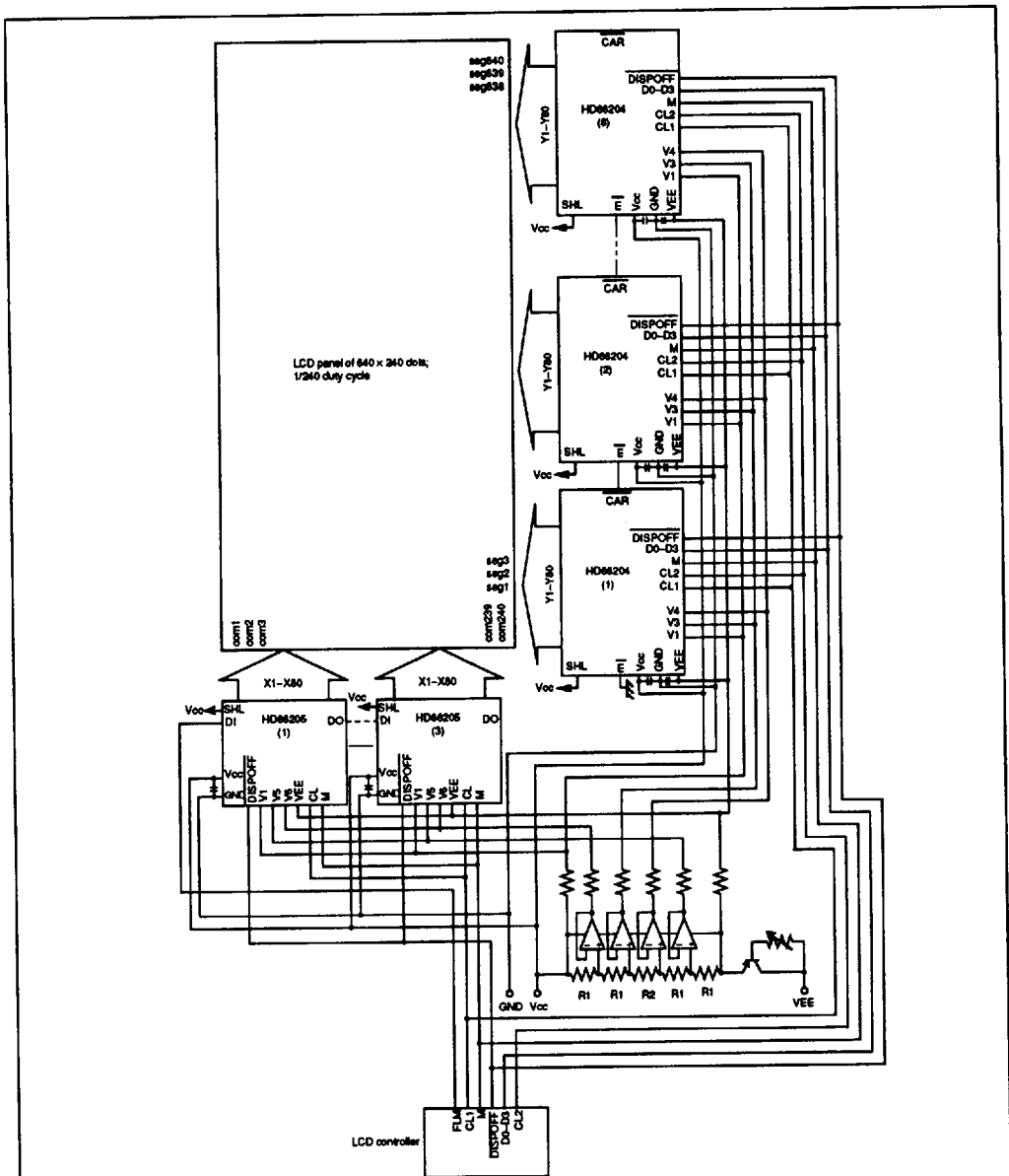

Figure 6 Relation between SHL and LCD Output Destinations

HD66205

Application Example



- Notes:
1. The resistances of R1 and R2 depend on the type of the LCD panel used. For example, for an LCD panel with a 1/15 bias, R1 and R2 must be 3 kΩ and 33 kΩ, respectively. That is, $R1/(4 \cdot R1 + R2)$ should be 1/15.
 2. To stabilize the power supply, place two 0.1-μF capacitors near each LCD driver: one between the V_{CC} and GND pins, and the other between the V_{CC} and V_{EE} pins.

Absolute Maximum Ratings

Item	Symbol	Rating	Unit	Notes
Power supply voltage for logic circuits	V_{CC}	-0.3 to +7.0	V	1
Power supply voltage for LCD drive circuits	V_{EE}	$V_{CC} - 30.0$ to $V_{CC} + 0.3$	V	
Input voltage 1	V_{T1}	-0.3 to $V_{CC} + 0.3$	V	1, 2
Input voltage 2	V_{T2}	$V_{EE} - 0.3$ to $V_{CC} + 0.3$	V	1, 3
Operating temperature	T_{opr}	-20 to +75	°C	
Storage temperature	T_{stg}	-55 to +125	°C	4

- Notes:
1. The reference point is GND (0 V).
 2. Applies to pins CL, M, SHL, DI, DISPOFF.
 3. Applies to pins V1, V5, and V6.
 4. -40 to +125°C for TCP devices.
 5. If the LSI is used beyond its absolute maximum ratings, it may be permanently damaged. It should always be used within its electrical characteristics in order to prevent malfunctioning or degradation of reliability.

Electrical Characteristics

DC Characteristics for the HD66205F/HD66205TF ($V_{CC} = 5\text{ V} \pm 10\%$, $GND = 0\text{ V}$, $V_{CC} - V_{EE} = 10$ to 28 V, and $T_a = -20$ to +75°C, unless otherwise noted.)

Item	Symbol	Pins	Min.	Typ.	Max.	Unit	Condition	Notes
Input high voltage	V_{IH}	1	$0.7 \times V_{CC}$	—	V_{CC}	V		
Input low voltage	V_{IL}	1	0	—	$0.3 \times V_{CC}$	V		
Output high voltage	V_{OH}	2	$V_{CC} - 0.4$	—	—	V	$I_{OH} = -0.4\text{ mA}$	
Output low voltage	V_{OL}	2	—	—	0.4	V	$I_{OL} = 0.4\text{ mA}$	
Vi-Yj on resistance	R_{ON}	3	—	—	2.0	k Ω	$I_{ON} = 100\text{ }\mu\text{A}$	1
Input leakage current 1	I_{IL1}	1	-1.0	—	1.0	μA	$V_{IN} = V_{CC}$ to GND	
Input leakage current 2	I_{IL2}	4	-25	—	25	μA	$V_{IN} = V_{CC}$ to V_{EE}	
Current consumption 1	I_{GND}	—	—	—	100	μA	$f_{CL} = 20\text{ kHz}$ $V_{CC} - V_{EE} = 28\text{ V}$	2
Current consumption 2	I_{EE}	—	—	150	500	μA	Same as above	2

Pins and notes on next page.

HD66205

DC Characteristics for the HD66204FL/HD66204TFL/HD66204T ($V_{CC} = 2.7$ to 5.5 V, $GND = 0$ V, $V_{CC} - V_{EE} = 10$ to 28 V, and $T_a = -20$ to $+75^\circ\text{C}$, unless otherwise noted.)

Item	Symbol	Pins	Min.	Max.	Unit	Condition	Notes
Input high voltage	V_{IH}	1	$0.7 \times V_{CC}$	V_{CC}	V		
Input low voltage	V_{IL}	1	0	$0.3 \times V_{CC}$	V		
Output high voltage	V_{OH}	2	$V_{CC} - 0.4$	—	V	$I_{OH} = -0.4$ mA	
Output low voltage	V_{OL}	2	—	0.4	V	$I_{OL} = 0.4$ mA	
V_i - V_j on resistance	R_{ON}	3	—	2.0	k Ω	$I_{ON} = 100$ mA	1
Input leakage current 1	I_{IL1}	1	-1.0	1.0	μA	$V_{IN} = V_{CC}$ to GND	
Input leakage current 2	I_{IL2}	4	-25	25	μA	$V_{IN} = V_{CC}$ to V_{EE}	
Current consumption 1	I_{GND}	—	—	100	μA	$f_{CL} = 16.8$ kHz $f_M = 35$ Hz $V_{CC} = 3.0$ V $V_{CC} - V_{EE} = 28$ V	2
Current consumption 2	I_{EE}	—	—	250	μA	Same as above	2

Pins: 1. CL, M, SHL, DI, DISPOFF

2. DO

3. X_1 - X_{80} , V1, V5, V6

4. V1, V5, V6

Notes: 1. Indicates the resistance between one pin from X_1 - X_{80} and another pin from V1, V5, V6, and V_{EE} , when load current is applied to the X pin; defined under the following conditions.

$$V_{CC} - V_{EE} = 28 \text{ V}$$

$$V1, V6 = V_{CC} - \{1/10(V_{CC} - V_{EE})\}$$

$$V5 = V_{EE} + \{1/10(V_{CC} - V_{EE})\}$$

V1 and V6 should be near V_{CC} level, and V5 should be near V_{EE} level (figure 7). All voltage must be within ΔV . ΔV is the range within which R_{ON} , the LCD drive circuits' output impedance, is stable. Note that ΔV depends on power supply voltage $V_{CC} - V_{EE}$ (figure 8).

2. Input and output current is excluded. When a CMOS input is floating, excess current flows from the power supply through the input circuit. To avoid this, V_{IH} and V_{IL} must be held to V_{CC} and GND levels, respectively.

3. Applies to standby mode.

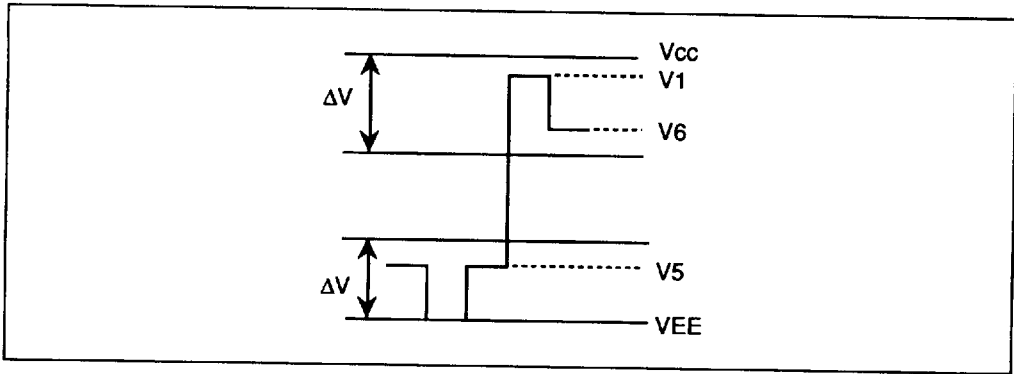

Figure 7 Relation between Driver Output Waveform and Level Voltages

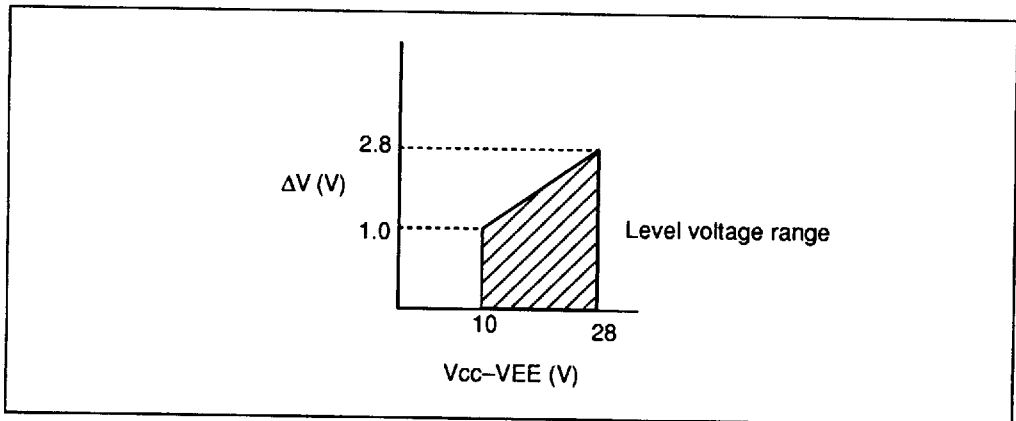

Figure 8 Relation between $V_{CC} - V_{EE}$ and ΔV

HD66205

AC Characteristics for the HD66205F/HD66205TF ($V_{CC} = 5\text{ V} \pm 10\%$, $GND = 0\text{ V}$, and $T_a = -20$ to $+75^\circ\text{C}$, unless otherwise noted.)

Item	Symbol	Pins	Min.	Max.	Unit	Note
Clock cycle time	t_{CYC}	CL	10	—	μs	
Clock high-level width 1	t_{CWH}	CL	50	—	ns	
Clock low-level width	t_{CWL}	CL	1.0	—	μs	
Clock rise time	t_r	CL	—	30	ns	
Clock fall time	t_f	CL	—	30	ns	
Data setup time	t_{DS}	DI, CL	100	—	ns	
Data hold time	t_{DH}	DI, CL	100	—	ns	
Data output delay time	t_{DD}	DO, CL	—	3.0	μs	1
Data output hold time	t_{DHW}	DO, CL	100	—	ns	

AC Characteristics for the HD66205FL/HD66205TFL/HD66205T ($V_{CC} = 2.7$ to 5.5 V , $GND = 0\text{ V}$, and $T_a = -20$ to $+75^\circ\text{C}$, unless otherwise noted.)

Item	Symbol	Pins	Min.	Max.	Unit	Note
Clock cycle time	t_{CYC}	CL	10	—	μs	
Clock high-level width 1	t_{CWH}	CL	80	—	ns	
Clock low-level width	t_{CWL}	CL	1.0	—	μs	
Clock rise time	t_r	CL	—	30	ns	
Clock fall time	t_f	CL	—	30	ns	
Data setup time	t_{DS}	DI, CL	100	—	ns	
Data hold time	t_{DH}	DI, CL	100	—	ns	
Data output delay time	t_{DD}	DO, CL	—	7.0	μs	1
Data output hold time	t_{DHW}	DO, CL	100	—	ns	

Notes: 1. The load circuit shown in figure 9 is connected.

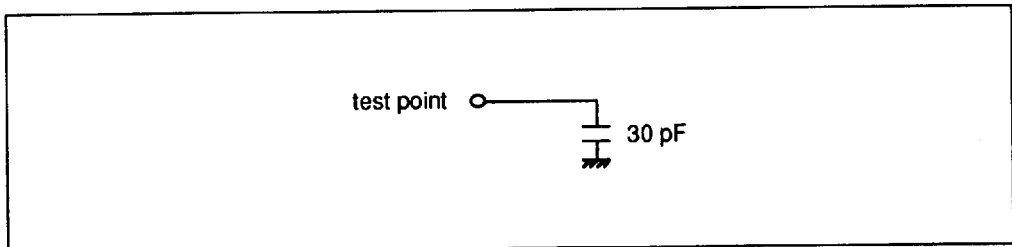

Figure 9 Load Circuit

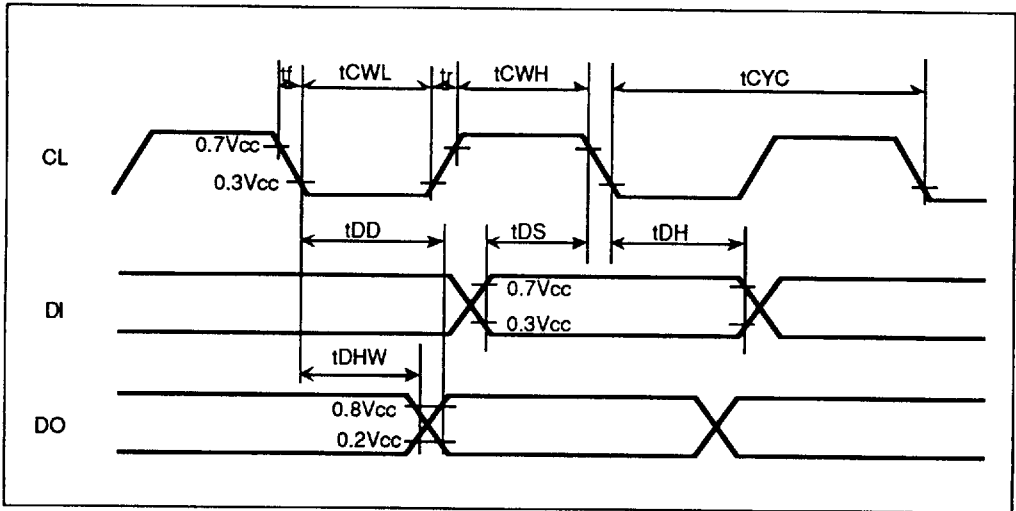

Figure 10 LCD Controller Interface Timing