

# HF2150/HF2151 MINIATURE HIGH POWER RELAY



File No.:E134517



File No.:CQC02001001951

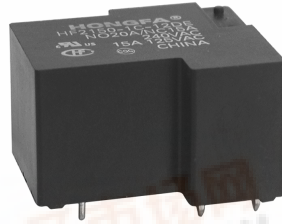

### Features

- \* 30A switching capabilities
- \* PCB coil terminals, ideal for heavy duty load
- \* Heavy load up to 7,200VA
- \* Sealed IP67 & Unsealed type available
- \* Class B, Class F insulation available

### CONTACT DATA

Contact Arrangement	1A	1B	1C(NO)	1C(NC)
Initial Contact Resistance	20mΩ (at rated Load)			
Contact Material	AgCdO			
Contact Rating (Res. Load)	30A 240VAC 20A 30VDC	15A 240VAC 10A 30VDC	20A 240VAC 20A 30VDC	10A 240VAC 10A 30VDC
Max. Switching Capacity	7200VA 600W	3600VA 300W	4800VA 600W	2400VA 300W
Max. switching voltage	277VAC/30VDC			
Max. switching current	30A	15A	20A	10A
Mechanical life	1 x 10 <sup>7</sup> ops			
Electrical life	1 x 10 <sup>6</sup> ops			

### COIL

Coil Power	DC: 0.9W
Coil Voltage	5 to 110VDC
Coil Resistance	See table below

### COIL DATA

Nominal Voltage VDC	Pick-up Voltage VDC	Drop-out Voltage VDC	Coil Resistance Ω
5	3.75	0.5	27 ± 10%
6	4.50	0.6	40 ± 10%
9	6.75	0.9	97 ± 10%
12	9.00	1.2	155 ± 10%
15	11.25	1.5	256 ± 10%
18	13.50	1.8	380 ± 10%
24	18.00	2.4	660 ± 10%
48	36.00	4.8	2560 ± 10%
70	52.50	7.0	5500 ± 10%
110	82.50	11.0	13450 ± 10%

Note:When requiring pull-in voltage <75% of nominal voltage, special order allowed.

### CHARACTERISTICS

Initial Insulation Resistance	1000MΩ, 500VDC
Dielectric Strength	Between coil and Contacts 2500VAC 1min.
	Between open contacts 1500VAC 1min.
Operate time (at nomi. Volt.)	Max. 15ms
Release time (at nomi. Volt.)	Max. 10ms
Ambient temperature	Class B -55°C to +100°C
	Class F -55°C to +125°C
Shock Resistance	Functional 98 m/s <sup>2</sup>
	Destructive 980 m/s <sup>2</sup>
Vibration Resistance	DA: 1.5mm, 10 to 55Hz
Humidity	98%, +40°C
Termination	PCB
Unit weight	Approx. 35g
Construction	Sealed IP67& Unsealed



## SAFETY APPROVAL RATINGS

UL

Load type	Volts	Form A (NO)	Form B (NC)	From C (NO)	From C (NC)
General Purpose	125/240VAC	30A	15A	—	15A
	277VAC	30A	30A	30A	30A
Resistive	125/240VAC	30A	15A	—	—
	30VDC	20A	10A	20A	10A
	277VAC	20A	—	—	—
	240VAC	15A	—	—	—
Ballast	125/240/277VAC	6A	3A	6A	3A
Pilot Duty	125VAC	800VA	290VA	800VA	290VA
	125VAC	690VA	—	690VA	—
	125VAC	800VA	—	800VA	—
	240VAC	1152VA	768VA	1152VA	768VA
	277VAC	764VA	—	764VA	—
Motor load	125VAC	1HP	1/4HP	1HP	1/4HP
	240VAC	2HP	1HP	2HP	1HP
	125VAC	1HP	—	1HP	—
	125/277VAC	3/4HP	—	3/4HP	—
Definite Purpose (LRA-loaded rotor) (FLA-full load)	120VAC	82.8LRA, 13.8FLA	—	82.8LRA, 13.8FLA	—
	125VAC	96LRA, 30FLA	33LRA, 10FLA	60LRA, 20FLA	33LRA, 10FLA
	125VAC	60LRA, 20FLA	30LRA, 12FLA	60LRA, 20FLA	30LRA, 12FLA
	125VAC	82.8LRA, 27FLA	—	82.8LRA, 27FLA	—
	240VAC	80LRA, 30FLA	33LRA, 10FLA	80LRA, 20FLA	33LRA, 10FLA
	240VAC	41.4LRA, 6.9FLA	—	41.4LRA, 6.9FLA	—
	277VAC	60LRA, 20FLA	—	60LRA, 20FLA	—
Tungsten	125VAC	15A	—	15A	—
	240VAC	5A	—	5A	3A
	120VAC	—	3A	—	—
	240VAC	—	3A	—	—

General Purpose Power Relays HF2150

## ORDERING INFORMATION

Type	HF2150 / HF2151 /	1A	12D	E	F
Contact arrangement	1A: SPST-NO 1B: SPST-NC 1C: SPDT				
Coil Voltage	DC: 5 to 110V				
Structure	E: Sealed IP67 Nil: Unsealed				
Insulation Standard	F: Class F Nil: Class B				

## OUTLINE DIMENSIONS, WIRING DIAGRAM AND PC BOARD LAYOUT

Outline Dimensions

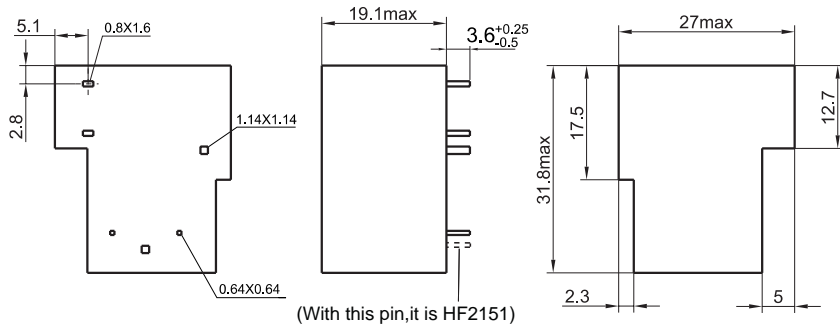

PCB layout

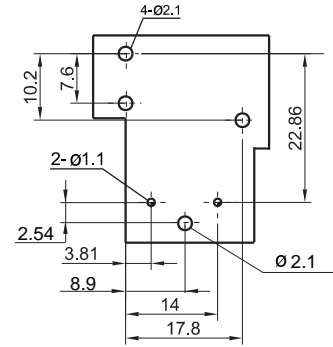

## CHARACTERISTICS CURVE

MAXIMUM SWITCHING POWER

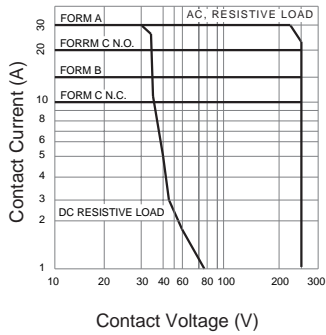

COIL TEMPERATURE RISE

