



HT16565 24 Hour System VFD Digital Clock

Features

- VFD display 24 hour clock function
- 4.194304MHz crystal oscillation
- Zero adjust function
- Integrated voltage regulator permits wide 4V to 16V operating voltage range
- Four level contrast control function
- 44-pin QFP package

General Description

The HT16565 provides direct drive to VFD panels to implement a 24 hour clock function. In addition to obtaining its time base from a 4.194304MHz crystal oscillation source and in having a wide operating voltage, the device also contains a host of other features. These in-

clude a choice of adjustment modes, including single push increment or 2Hz fast forward functions. Additional features are provided in the form of Zero adjustment and four levels of contrast control.

Block Diagram

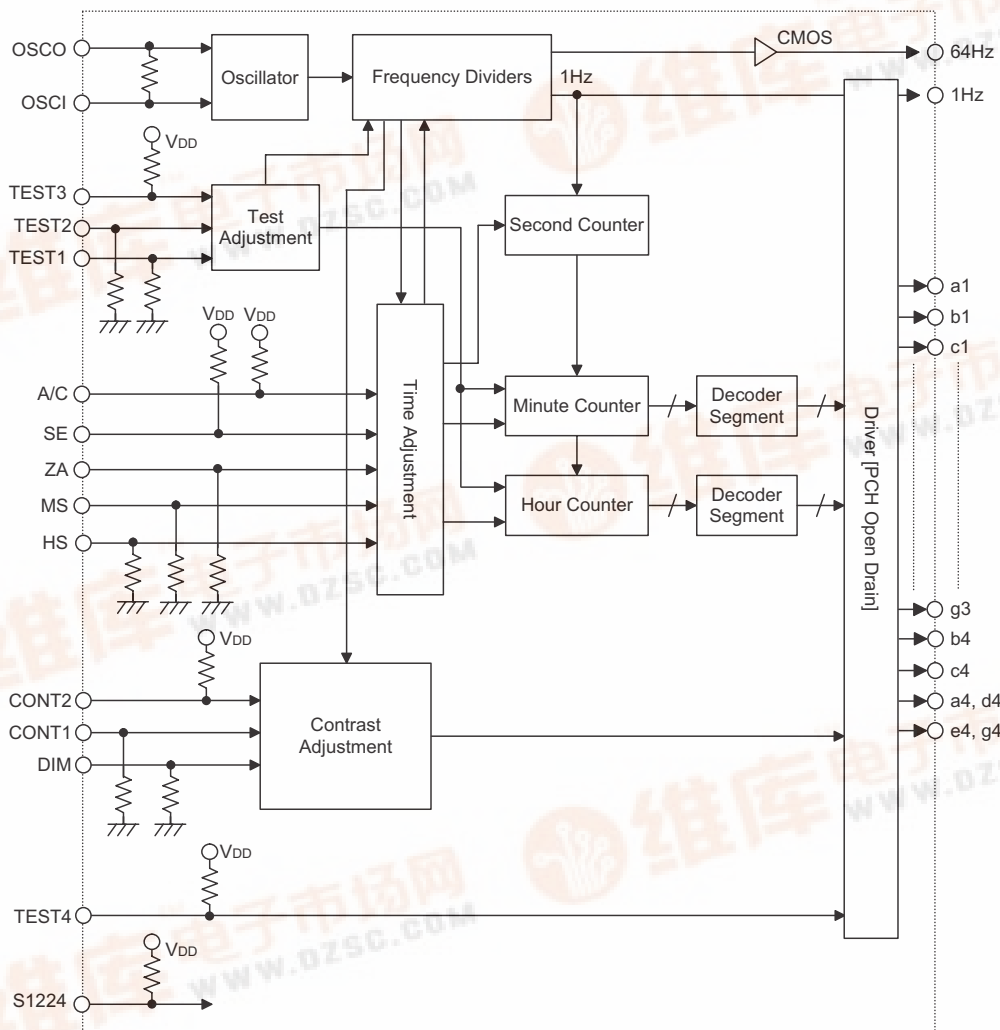

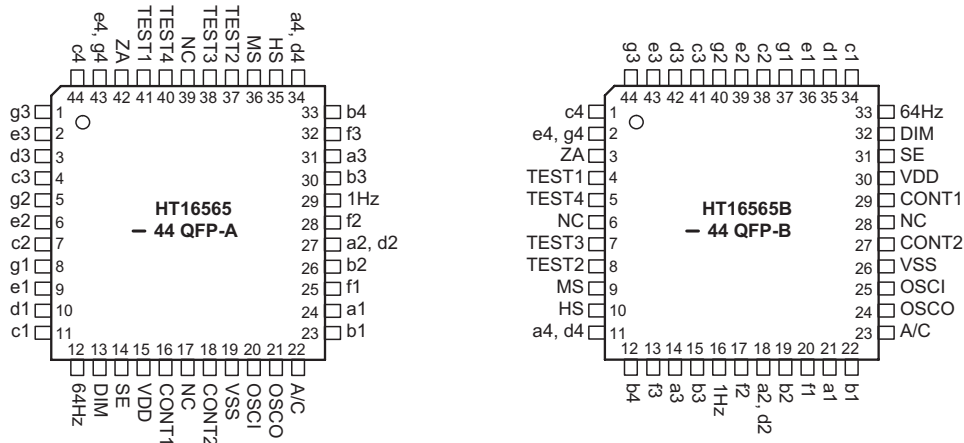
Pin Assignment

Pin Description

Pin Name	I/O	Description
VDD	O	High voltage power supply pin.
VSS	—	Ground pin.
DIM	I	Illumination level control pins.
CONT1	I	Internally connected to pull-down resistors.
CONT2	I	Illumination level control pins. Internally connected to pull-up resistors.
A/C	I	When the A/C pin is low, the internal circuits are reset. The reset pulse width should be more than 2 μ s. Internally connected to a pull-up resistor.
ZA	I	Zero adjustment pin. Internally connected to a pull-down resistor.
HS	I	Hour adjustment pin. Internally connected to a pull-down resistor.
MS	I	Minute adjustment pin. Internally connected to a pull-down resistor.
SE	I	Set enable pin. Internally connected to a pull-up resistor.
OSCO	O	Crystal oscillator pin
OSCI	I	
TEST1, TEST2	I	IC test pin - should be left open or kept at a low level
TEST3, TEST4	I	IC test pin - should be left open or kept at a high level
64Hz	O	64Hz signal output pin for oscillation frequency adjustment
a1, a3 ~ b2, b4, c4	O	Segment output pins for VFD
a4, d4, e4, g4		
1Hz		

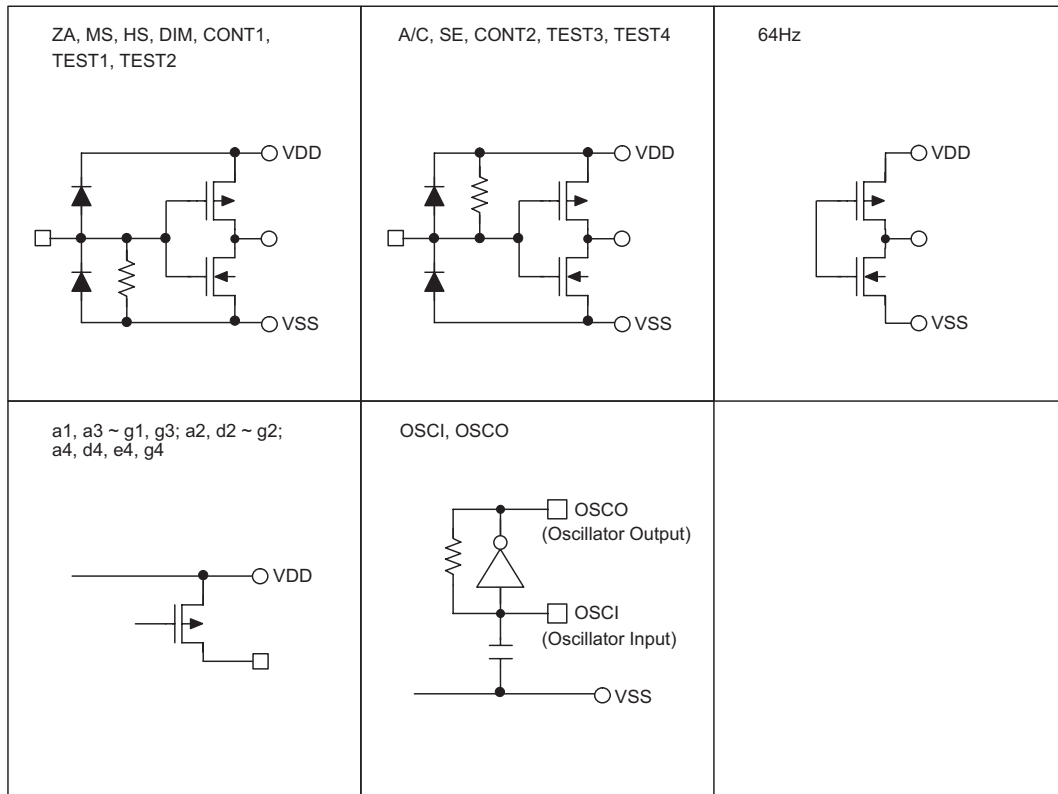
Approximate Internal Connections



Absolute Maximum Ratings

Logic Supply Voltage $V_{SS}-0.3V$ to $V_{SS}+6.5V$	Driver Supply Voltage $V_{SS}-0.3V$ to $V_{SS}+20V$
High Input Voltage $V_{SS}-0.3V$ to $V_{CC}+0.3V$	High Output Voltage $V_{SS}-0.3V$ to $V_{CC}+0.3V$
Driver Output Voltage $V_{SS}-0.3V$ to V_{DD}	Driver Output Current (Segment Driver) $-10mA$ to $+2mA$
Driver Output Current (Grid Driver) $-7mA$ to $+20mA$	Storage Temperature $-55^{\circ}C$ to $+150^{\circ}C$
Operating Temperature $-40^{\circ}C$ to $+85^{\circ}C$	

Note: These are stress ratings only. Stresses exceeding the range specified under "Absolute Maximum Ratings" may cause substantial damage to the device. Functional operation of this device at other conditions beyond those listed in the specification is not implied and prolonged exposure to extreme conditions may affect device reliability.

Recommended Operating Conditions

Symbol	Parameter	Min.	Typ.	Max.	Unit
V_{DD}	Power Supply Voltage	4	—	16	V
f_{OSC}	Oscillation Frequency	—	4.194304	—	MHz
t_{OP}	Operating Temperature	-40	—	85	$^{\circ}C$

D.C. Characteristics
 $V_{DD}=6.0V, V_{SS}=0V, T_a=-40^{\circ}C-85^{\circ}C$

Symbol	Parameter	Test Conditions		Min.	Typ.	Max.	Unit
		V_{DD}	Conditions				
V_{IH}	High Input Voltage	6V	—	4.3	—	—	V
V_{IL}	Low Input Voltage	6V	—	—	—	1.0	V
I_{IH}	Hi-level Input Current	6V	$V_I=V_{DD}$ for TEST1, TEST2, ZA, MS, HS, DIM, CONT1	30	—	150	μA
I_{IL1}	Low-level Input Current	6V	$V_I=V_{SS}$ for TEST3, TEST4	-120	—	-800	μA
I_{IL2}			$V_I=V_{SS}$ for A/C	-3	—	-12	μA
I_{IL3}			$V_I=V_{SS}$ for SE, CONT2	-30	—	-150	μA
V_{OL}	Low-level Output current	6V	$I_{OL}=V_{SS}$ for all pin	5.9	—	—	V
V_{OH}	Hi-level Output current	6V	$I_{OH}=V_{SS}$ for 64Hz pin	—	—	0.1	V
I_{OH1}	Output Current	6V	$V_{OH}=4.0V$ for 1Hz, a2, d2, a4, d4, e4, g4	—	—	-2000	μA
I_{OL1}	Output Current	6V	$V_{OL}=0V$ for 1Hz, a2, d2, a4, d4, e4, g4	1	—	—	μA
I_{OH2}	Output Current	6V	$V_{OH}=4.0V$, Other segment output pins except above	—	—	-1000	μA
I_{OL2}	Output Current	6V	$V_{OL}=V_{SS}$, Other segment output pins except above	1	—	—	μA
I_{OH3}	Output Current	6V	$V_{OH}=5.5V$ for 64Hz pin	—	—	-100	μA
I_{OL3}	Output Current	6V	$V_{OL}=0.5V$ for 64Hz pin	100	—	—	μA
I_{DD}	Dynamic Current Consumption	6V	$f_{OSC}=4.194304MHz$, No load, $C_{IN}=39pF\pm 5\%$, $C_{OUT}=33pF\pm 5\%$, $C_I=70\Omega\pm 5\%$	—	—	2	mA

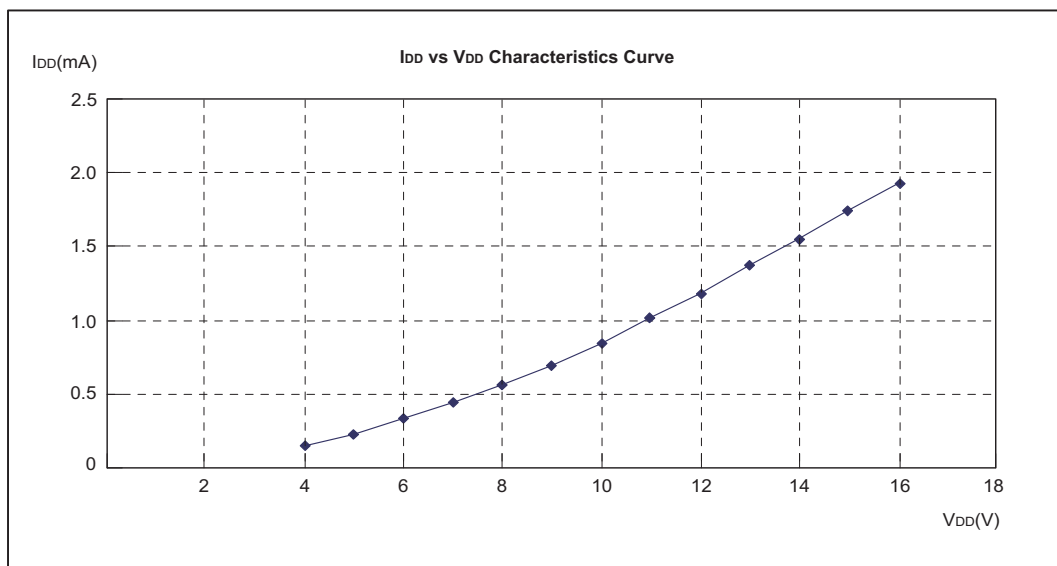
Characteristics Curves
 V_{DD} vs I_{DD} Characteristics Curve
 $T_a=25^{\circ}C$

Functional Description

VFD Display Driving

The device can directly drive VFD clock panels dynamically. The clock will be displayed in a 24-hour format with the hours ranging from 0 to 23 and minutes from 00 to 59. If the most significant numeral is zero then the display will be extinguished.

- Segment connections
A 7-segment display is shown below showing the illumination pattern for each numeral.

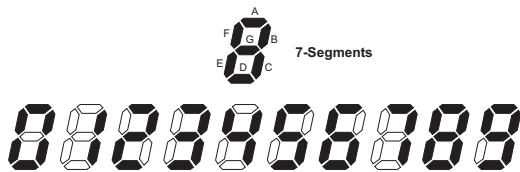

As the device is designed for clock applications, four 7-segment displays are required to display the correct time output. The connections for the segments are shown below, however it should be noted that the fourth segment only requires two of its segments to be driven.

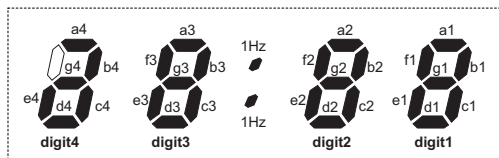

Other Pin Functions

The external reset pin A/C is used to reset the internal circuit of the device. When this pin is pulled low the device will be reset, when the pin is allowed to go high, via its internal pull-high resistor, then the display will indicate a "0:00" output.

In the open status, the SE pin is held to "high" level by a pull-high resistor, enabling the inputs from MS, HS and ZA pins. These inputs become invalid by setting this pin to a "low" level externally.

The 64Hz pin allows monitoring of the system frequency to allow frequency adjustments to be executed. As the name suggests, this output pin will continuously output a frequency of 64Hz.

In the open status, the TEST1 and TEST2 pins are kept at a "0" level by pull-down resistors.

In the open status, the TEST3 and TEST4 pins are kept at a "1" level by pull-up resistors.

The Test pin function is as shown in the following table.

TEST select function 1

Switch Pin Name			Operating mode
TEST1	TEST2	TEST3	
0 (or Open)	0 (or Open)	1 (or Open)	Normal function.
Φ (Pulse)	1	1 (or Open)	Input pulses to the 16.384kHz system of the circuit.
1	Φ (Pulse)	1 (or Open)	Input pulses to the 16.384kHz system of the circuit.
1	Φ (Pulse)	0	Input pulses to the 64Hz system of the circuit.
Φ (Pulse)	1	0	Input pulses to the 64Hz system of the circuit.
Φ (Pulse)	0 (or Open)	0	Input pulses for the minute and hour counters, which advances 1 count with 1 pulse. No carry functions for hour and minute counters.

TEST select function 2

Switch Pin Name				Operating mode
TEST3	DIM	CONT1	CONT2	
0	Φ (Pulse)	*	*	The pulse widths of the all segment outputs are controlled by the pulse width of the DIM signal
0	0	*	*	Sets all segment outputs to high impedance

Note: "*" Indicates that the input level can be "0" and "1"

Three illumination level set pins, DIM, CONT1 and CONT2 are provided to give control over the display brightness level, as shown in the following table.

Switch Pin Name			Operating mode
DIM	CONT1	CONT2	
0 (or Open)	*	*	100% duty display
1	0 (or Open)	1 (or Open)	25% (1/4) duty display at 4096Hz
1	0 (or Open)	0	12.5% (1/8) duty display at 4096Hz
1	1	1 (or Open)	6.25% (1/16) duty display at 4096Hz

Note: "1" high level, "0" low level, "*" don't care

Device Functions

- **Reset**
Although the device is provided with an external reset pin A/C, the device will in fact reset itself when power is applied, eliminating the need for external reset components. The usual provision of an external capacitor is not required as an internal reset capacitor is integrated within the device.
- **Chatter removal**
The device contains circuits which are connected to input pins HS, MS and ZA to remove chatter of less than 31.25ms.
- **Oscillator**
The basic time base frequency for this device is determined by an external 4.194304MHz crystal. When an external crystal along with two small external capacitors are connected to the two oscillator pins, the internal oscillator circuit will ensure generation of the correct time base signals. The oscillation frequency, although determined by the external crystal frequency, will also be influenced by the external capacitors, the crystal inherent capacitance and the residual capacitance of the external PCB tracks. To ensure accurate frequency generation, the crystal specification should be taken into account and care taken to place the external capacitors and crystal as close to the device as possible.

Time Adjustment Operation

- **Hour/minute adjustment**
Both the minutes and hour displays can be adjusted separately or both together in a fast forward format. The hour set pin, HS, and the minutes set pin, MS, are used to make these adjustments. Both of these pins are connected to internal pull-low resistors. Each time one of these lines is pulled high, the respective hour or minute value will increment by one, also if the line is continuously held high then the respective value will increment automatically at a rate of 2Hz. Both values will increment together if both lines are pulled high simultaneously. Note that no carry functions will be implemented when either the hour or minute value overflows.

- **Zero adjustment**

A zero adjust function is also included within the device and is controlled by the ZA pin. This pin is connected to an internal pull low resistor. Pulling this line high will reset both the internal minutes and seconds value, however the way in which the display is reset depends upon the present value of display. If the minute value is presently less than 30 the only the second and minute values will be reset to zero and the hour value remain unchanged. However if the minute value is presently at a value of 30 or higher then when the zero adjustment function is executed, a carry will be implemented and the hour value will be increment by one. The following table illustrates a few examples of this operation.

Zero Adjust Examples					
Present Time			After Zero Adjust		
Hr.	Min.	Sec.	Hr.	Min.	Sec.
1	30	00	2	00	00
2	00	00	2	00	00
2	29	59	2	00	00
2	30	00	3	00	00
2	59	59	3	00	00
3	29	59	3	00	00

Application Circuits

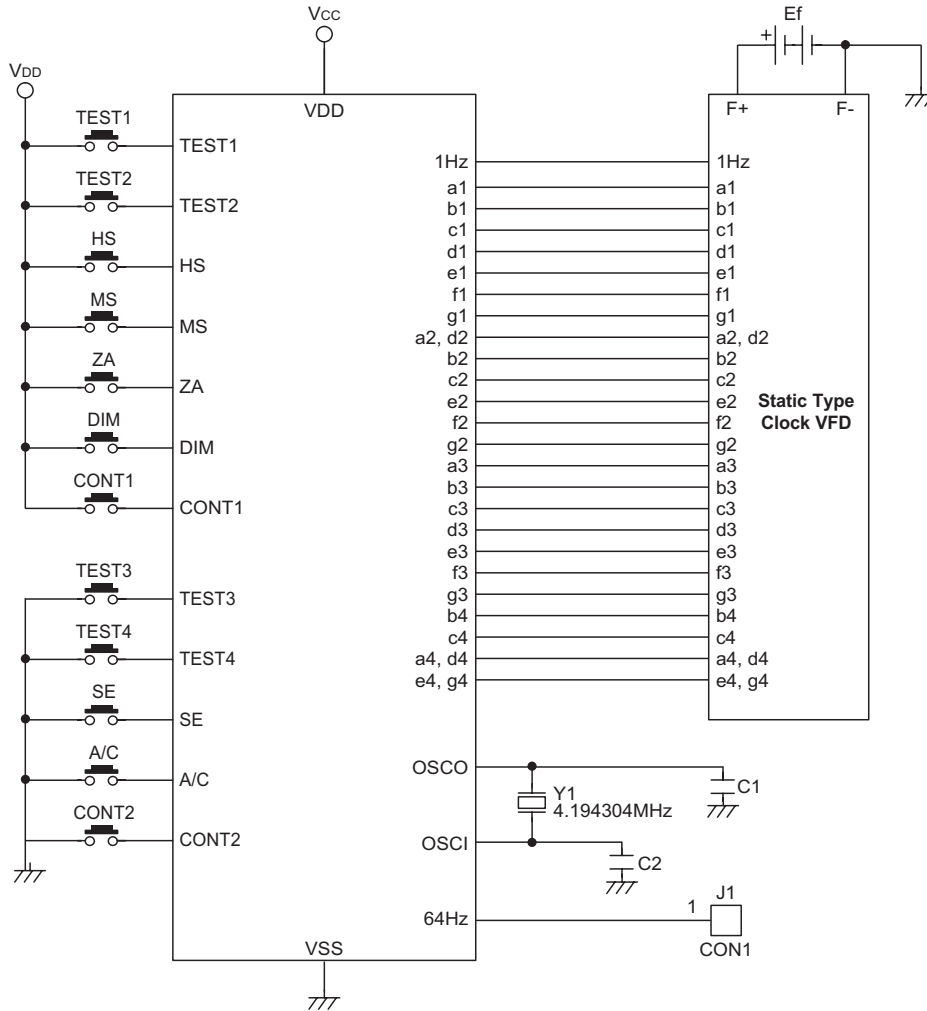

Note: Capacitors C1 and C2 can adjust the frequency accuracy

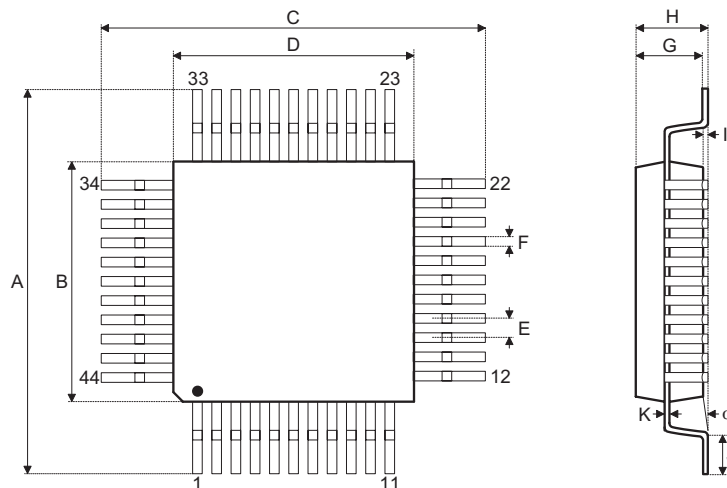
Package Information
44-pin QFP (10×10) Outline Dimensions

Symbol	Dimensions in mm		
	Min.	Nom.	Max.
A	13	—	13.4
B	9.9	—	10.1
C	13	—	13.4
D	9.9	—	10.1
E	—	0.8	—
F	—	0.3	—
G	1.9	—	2.2
H	—	—	2.7
I	—	0.1	—
J	0.73	—	0.93
K	0.1	—	0.2
α	0°	—	7°

Holtek Semiconductor Inc. (Headquarters)

No.3, Creation Rd. II, Science Park, Hsinchu, Taiwan
Tel: 886-3-563-1999
Fax: 886-3-563-1189
<http://www.holtek.com.tw>

Holtek Semiconductor Inc. (Taipei Sales Office)

4F-2, No. 3-2, YuanQu St., Nankang Software Park, Taipei 115, Taiwan
Tel: 886-2-2655-7070
Fax: 886-2-2655-7373
Fax: 886-2-2655-7383 (International sales hotline)

Holtek Semiconductor Inc. (Shanghai Sales Office)

7th Floor, Building 2, No.889, Yi Shan Rd., Shanghai, China 200233
Tel: 86-21-6485-5560
Fax: 86-21-6485-0313
<http://www.holtek.com.cn>

Holtek Semiconductor Inc. (Shenzhen Sales Office)

5/F, Unit A, Productivity Building, Cross of Science M 3rd Road and Gaoxin M 2nd Road, Science Park, Nanshan District, Shenzhen, China 518057
Tel: 86-755-8616-9908, 86-755-8616-9308
Fax: 86-755-8616-9722

Holtek Semiconductor Inc. (Beijing Sales Office)

Suite 1721, Jinyu Tower, A129 West Xuan Wu Men Street, Xicheng District, Beijing, China 100031
Tel: 86-10-6641-0030, 86-10-6641-7751, 86-10-6641-7752
Fax: 86-10-6641-0125

Holtek Semiconductor Inc. (Chengdu Sales Office)

709, Building 3, Champagne Plaza, No.97 Dongda Street, Chengdu, Sichuan, China 610016
Tel: 86-28-6653-6590
Fax: 86-28-6653-6591

Holtek Semiconductor (USA), Inc. (North America Sales Office)

46729 Fremont Blvd., Fremont, CA 94538
Tel: 1-510-252-9880
Fax: 1-510-252-9885
<http://www.holtek.com>

Copyright © 2007 by HOLTEK SEMICONDUCTOR INC.

The information appearing in this Data Sheet is believed to be accurate at the time of publication. However, Holtek assumes no responsibility arising from the use of the specifications described. The applications mentioned herein are used solely for the purpose of illustration and Holtek makes no warranty or representation that such applications will be suitable without further modification, nor recommends the use of its products for application that may present a risk to human life due to malfunction or otherwise. Holtek's products are not authorized for use as critical components in life support devices or systems. Holtek reserves the right to alter its products without prior notification. For the most up-to-date information, please visit our web site at <http://www.holtek.com.tw>.