



HT45B0C MOSFET Gate Driver

Technical Document

- [Tools Information](#)
- [FAQs](#)
- [Application Note](#)

Features

- Three low side and high side MOSFET driver
- Low side drive supply range from 9V~20V with low voltage protection
- High side driver output maximum voltage is 80V
- Input logic supply range from 4.5V~5.5V
- Low voltage protection function
- 24-pin SKDIP/SOP package

General Description

The devices are for power MOSFET gate drivers, which interface directly to driver the power MOSFET. There are three high side drivers and three low side drivers to driver six N-channel power MOSFET.

The high side driver operates up to 80 Volts. The input logic power is from VDD, so it can easy to interface with microcontroller.

Block Diagram

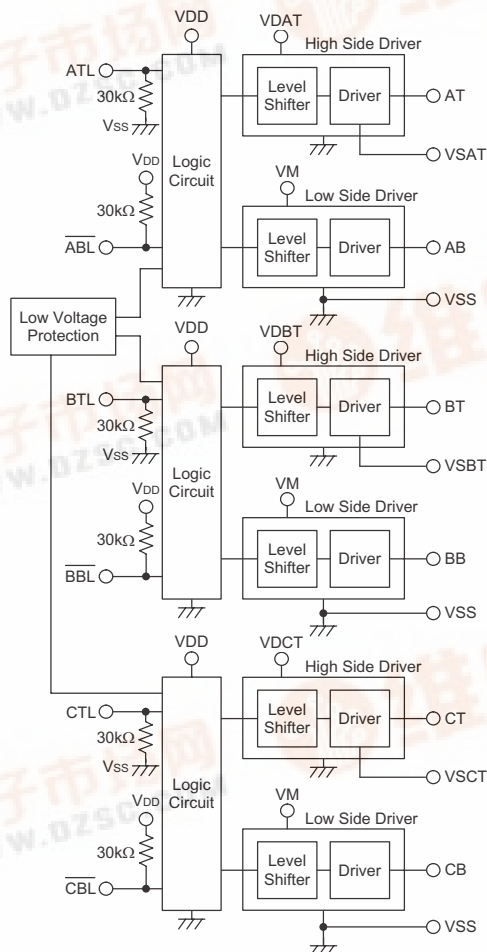

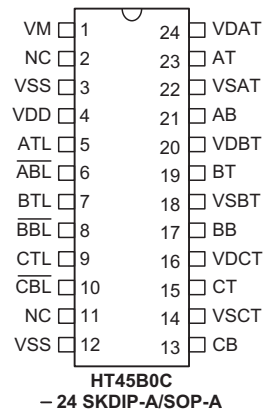
Pin Assignment

Pin Description

Pin Name	I/O	Description
V DAT V DBT V DCT	—	Upper side power MOSFET gate driver positive power supply
A T B T C T	O	High side high voltage drive output
V SAT V SBT V SCT	—	Upper side power MOSFET gate driver negative power supply
A B B B C B	O	Low side high voltage drive output
A TL B TL C TL	I	Logic input for high side gate driver output (AT, BT, CT)
$\overline{A} B L$ $\overline{B} B L$ $\overline{C} B L$	I	Logic input for low side gate driver output (AB, BB, CB)
V M	—	Low side driver power supply and power supply for V DAT/V SAT, V DBT/V SBT, V DCT/V SCT charging capacitors
V DD	—	Logic power supply
V SS	—	Negative power supply, ground

Absolute Maximum Ratings

VDD Supply Voltage	$V_{SS}-0.3V$ to $V_{SS}+6.0V$
VM Supply Voltage	$V_{SS}-0.3V$ to $V_{SS}+20V$
VDAT, VDBT, VDCT Supply Voltage	$V_{SS}-0.3V$ to $V_{SS}+80V$
VSAT, VSBT, VSCT Supply Voltage	$V_{SS}-0.3V$ to $V_{SS}+70V$
Input Voltage	$V_{SS}-0.3V$ to $V_{DD}+0.3V$
Storage Temperature	$-50^{\circ}C$ to $125^{\circ}C$
Operating Temperature	$-40^{\circ}C$ to $85^{\circ}C$
I_{OL} Total	150mA
I_{OH} Total	-100mA
Total Power Dissipation	500mW

Note: These are stress ratings only. Stresses exceeding the range specified under "Absolute Maximum Ratings" may cause substantial damage to the device. Functional operation of this device at other conditions beyond those listed in the specification is not implied and prolonged exposure to extreme conditions may affect device reliability.

D.C. Characteristics
 $T_a=25^{\circ}C$

Symbol	Parameter	Test Conditions		Min.	Typ.	Max.	Unit
		VDD	Conditions				
V_{DD}	Operating Voltage	—	—	4.5	—	5.5	V
V_M	Low Side Driver Power Supply	—	—	V_{LVH}	—	20	V
V_{LVH}	V_M Low Voltage Protection Voltage	—	High going	8	9	10	V
V_{LVL}	V_M Low Voltage Protection Voltage	—	Low going	7	8	9	V
I_{DD}	V_{DD} Operating Current	5V	No load	—	1	2	mA
I_{VM}	V_M Operating Current	—	$V_M=20V$	—	0.5	1	mA
V_{IL}	Input Low Voltage for ATL, BTL, CTL, ABL, BBL, CBL	5V	—	0	—	$0.3V_{DD}$	V
V_{IH}	Input High Voltage for ATL, BTL, CTL, ABL, BBL, CBL	5V	—	$0.7V_{DD}$	—	V_{DD}	V
I_{OL}	AT, AB, BT, BB, CT and CB Sink Current	—	V_M and $VDxT-VSxT=15V$, $V_{OL}=1.5V$	25	40	—	mA
I_{OH}	AT, AB, BT, BB, CT and CB Source Current	—	V_M and $VDxT-VSxT=15V$, $V_{OH}=13.5V$	-12.5	-20	—	mA
I_{OLS}	AT, AB, BT, BB, CT and CB Output Low Short Circuit Pulsed Current	—	V_M and $VDxT-VSxT=15V$, $V_O=15V$, $V_{IN}=V_{IL}$, pulse width $\leq 10\mu s$	—	380	—	mA
I_{OHS}	AT, AB, BT, BB, CT and CB Output High Short Circuit Pulsed Current	—	V_M and $VDxT-VSxT=15V$, $V_O=0V$, $V_{IN}=V_{IH}$, pulse width $\leq 10\mu s$	—	-165	—	mA
R_{PH}	Pull-high Resistance of ABL, BBL, CBL	5V	—	10	30	50	k Ω
R_{PL}	Pull-low Resistance of ATL, BTL, CTL	5V	—	10	30	50	k Ω

Note: $VDxT$ is VDAT, VDBT or VDCT

$VSxT$ is VSAT, VSBT or VSCT

The I_{OLS} and I_{OHS} parameters have been characterised but not 100% production tested.

A.C. Characteristics

Ta=25°C

Symbol	Parameter	Test Conditions			Min.	Typ.	Max.	Unit
		V _{DD}	V _M	Conditions				
t _{ON}	Turn-on Propagation Delay	5V	15V	C _L =1000pF, VDxT-VSxT=15V, VDxT=80V	—	—	250	ns
t _{OFF}	Turn-off Propagation Delay	5V	15V	C _L =1000pF, VDxT-VSxT=15V, VDxT=80V	—	—	150	ns
t _R	Turn-on Rising Time	5V	15V	C _L =1000pF, VDxT-VSxT=15V, VDxT=80V	—	—	250	ns
t _F	Turn-off Falling Time	5V	15V	C _L =1000pF, VDxT-VSxT=15V, VDxT=80V	—	—	120	ns
t _{IN}	Input Pulse Width for ATL, BTL, CTL, ABL, BBL, CBL	5V	15V	—	200	—	—	ns

Note: VDxT is VDAT, VDBT or VDCT

VSxT is VSAT, VSBT or VSCT

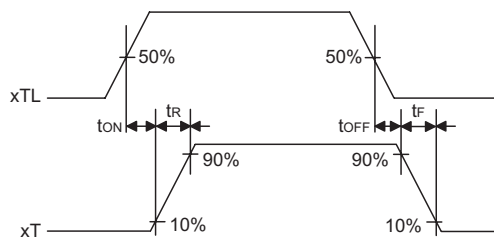
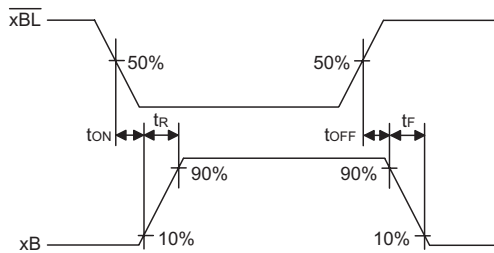

Note: x is A, B or C

Functional Description
Input/Output Truth Table

The output of the device is according the input pin. The true table is as follow:

ATL, BTL, CTL	ABL, BBL, CBL	Low Voltage Protection	AT, BT, CT	AB, BB, CB
0	1	N	VSAT, VSBT, VSCT	VSS, VSS, VSS
0	0	N	VSAT, VSBT, VSCT	VM, VM, VM
1	1	N	VDAT, VDBT, VDCT	VSS, VSS, VSS
1	0	N	VSAT, VSBT, VSCT	VSS, VSS, VSS
—	—	Y	VSAT, VSBT, VSCT	VSS, VSS, VSS

(ATL, ABL), (BTL, BBL) and (CTL, CBL) Truth Table

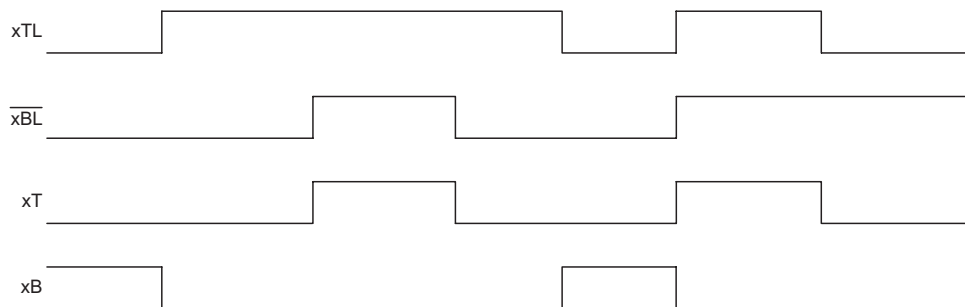
Timing Diagrams

Note: x is A, B or C

Package Information

24-pin SKDIP (300mil) Outline Dimensions

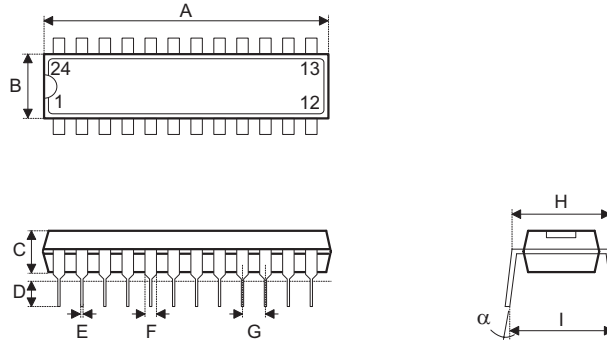

Symbol	Dimensions in mil		
	Min.	Nom.	Max.
A	1235	—	1265
B	255	—	265
C	125	—	135
D	125	—	145
E	16	—	20
F	50	—	70
G	—	100	—
H	295	—	315
I	345	—	360
α	0°	—	15°

24-pin SOP (300mil) Outline Dimensions

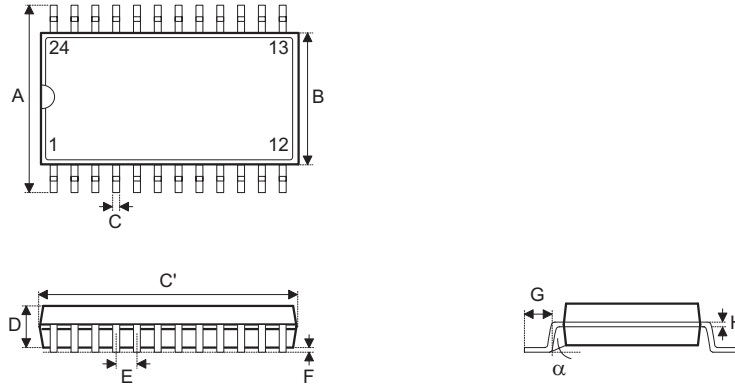

Symbol	Dimensions in mil		
	Min.	Nom.	Max.
A	394	—	419
B	290	—	300
C	14	—	20
C'	590	—	614
D	92	—	104
E	—	50	—
F	4	—	—
G	32	—	38
H	4	—	12
α	0°	—	10°

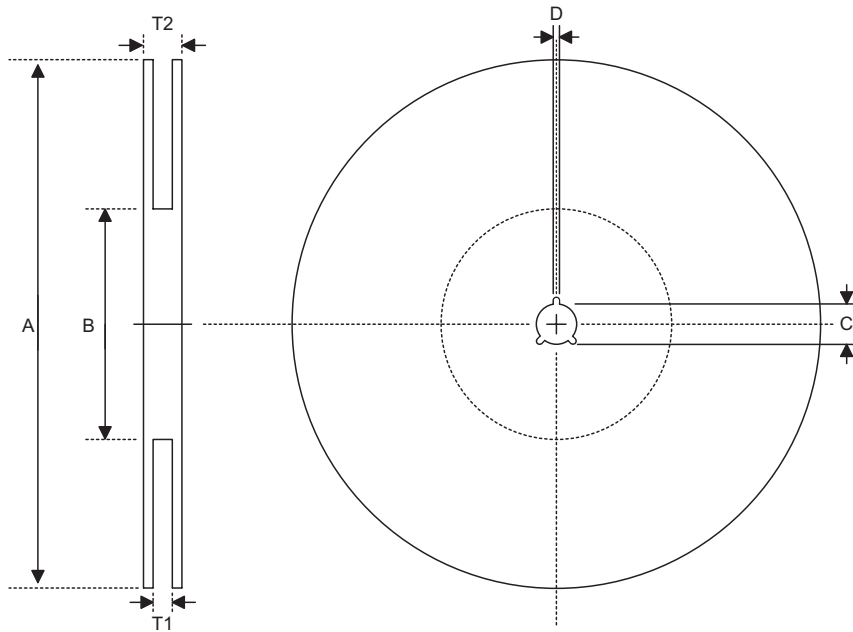
Product Tape and Reel Specifications
Reel Dimensions

SOP 24W

Symbol	Description	Dimensions in mm
A	Reel Outer Diameter	330±1
B	Reel Inner Diameter	62±1.5
C	Spindle Hole Diameter	13+0.5 -0.2
D	Key Slit Width	2±0.5
T1	Space Between Flange	24.8+0.3 -0.2
T2	Reel Thickness	30.2±0.2

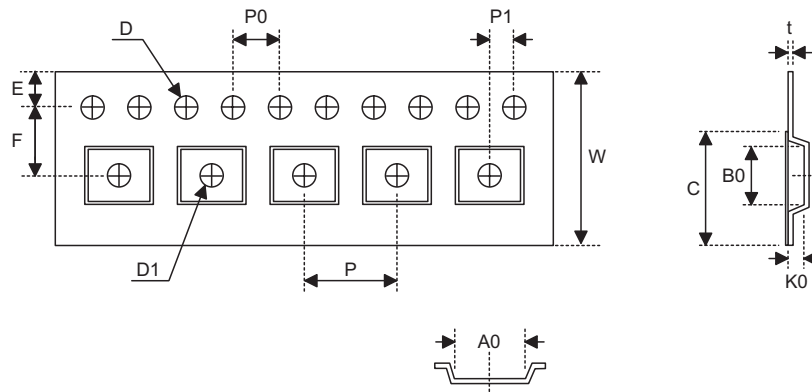
Carrier Tape Dimensions

SOP 24W

Symbol	Description	Dimensions in mm
W	Carrier Tape Width	24±0.3
P	Cavity Pitch	12±0.1
E	Perforation Position	1.75±0.1
F	Cavity to Perforation (Width Direction)	11.5±0.1
D	Perforation Diameter	1.55±0.1
D1	Cavity Hole Diameter	1.5±0.25
P0	Perforation Pitch	4±0.1
P1	Cavity to Perforation (Length Direction)	2±0.1
A0	Cavity Length	10.9±0.1
B0	Cavity Width	15.9±0.1
K0	Cavity Depth	3.1±0.1
t	Carrier Tape Thickness	0.35±0.05
C	Cover Tape Width	21.3

Holtek Semiconductor Inc. (Headquarters)

No.3, Creation Rd. II, Science Park, Hsinchu, Taiwan
Tel: 886-3-563-1999
Fax: 886-3-563-1189
<http://www.holtek.com.tw>

Holtek Semiconductor Inc. (Taipei Sales Office)

4F-2, No. 3-2, YuanQu St., Nankang Software Park, Taipei 115, Taiwan
Tel: 886-2-2655-7070
Fax: 886-2-2655-7373
Fax: 886-2-2655-7383 (International sales hotline)

Holtek Semiconductor Inc. (Shanghai Sales Office)

7th Floor, Building 2, No.889, Yi Shan Rd., Shanghai, China 200233
Tel: 86-21-6485-5560
Fax: 86-21-6485-0313
<http://www.holtek.com.cn>

Holtek Semiconductor Inc. (Shenzhen Sales Office)

5/F, Unit A, Productivity Building, Cross of Science M 3rd Road and Gaoxin M 2nd Road, Science Park, Nanshan District, Shenzhen, China 518057
Tel: 86-755-8616-9908, 86-755-8616-9308
Fax: 86-755-8616-9533

Holtek Semiconductor Inc. (Beijing Sales Office)

Suite 1721, Jinyu Tower, A129 West Xuan Wu Men Street, Xicheng District, Beijing, China 100031
Tel: 86-10-6641-0030, 86-10-6641-7751, 86-10-6641-7752
Fax: 86-10-6641-0125

Holtek Semiconductor Inc. (Chengdu Sales Office)

709, Building 3, Champagne Plaza, No.97 Dongda Street, Chengdu, Sichuan, China 610016
Tel: 86-28-6653-6590
Fax: 86-28-6653-6591

Holmate Semiconductor, Inc. (North America Sales Office)

46729 Fremont Blvd., Fremont, CA 94538
Tel: 1-510-252-9880
Fax: 1-510-252-9885
<http://www.holmate.com>

Copyright © 2006 by HOLTEK SEMICONDUCTOR INC.

The information appearing in this Data Sheet is believed to be accurate at the time of publication. However, Holtek assumes no responsibility arising from the use of the specifications described. The applications mentioned herein are used solely for the purpose of illustration and Holtek makes no warranty or representation that such applications will be suitable without further modification, nor recommends the use of its products for application that may present a risk to human life due to malfunction or otherwise. Holtek's products are not authorized for use as critical components in life support devices or systems. Holtek reserves the right to alter its products without prior notification. For the most up-to-date information, please visit our web site at <http://www.holtek.com.tw>.