

KMA199E

Programmable angle sensor

Rev. 01 — 18 October 2007

Product data sheet

1. Product profile

1.1 General description

The KMA199E is a magnetic angle sensor system. The MagnetoResistive (MR) sensor bridges and the mixed signal Integrated Circuit (IC) are integrated into a single package.

This angular measurement system KMA199E is pre-programmed, pre-calibrated and therefore, ready to use.

The KMA199E allows user specific adjustments of angular range, zero angle and clamping voltages. The settings are stored permanently in an Electrically Erasable Programmable Read-Only Memory (EEPROM).

1.2 Features

- High precision sensor for magnetic angular measurement
- Programmable user adjustments, including zero angle and angular range
- Single package sensor system
- Magnet-lost and power-lost detection
- Built-in transient protection
- User-programmable 32-bit identifier
- Ready to use
- Ratiometric output voltage
- Independent from the magnetic field strength above 35 kA/m
- Programming via One-Wire Interface (OWI)
- Fail-safe EEPROM
- High temperature range
- Factory calibrated

2. Pinning information

Table 1. Pinning

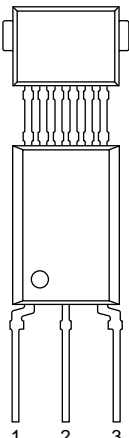
Pin	Symbol	Description	Simplified outline
1	V _{DD}	supply voltage	
2	GND	ground	
3	OUT/DIGINT	analog output voltage or digital interface	

3. Ordering information

Table 2. Ordering information

Type number	Package		
	Name	Description	Version
KMA199E	-	plastic single-ended multi-chip package; 6 interconnections; 3 in-line leads	SOT880

4. Functional diagram

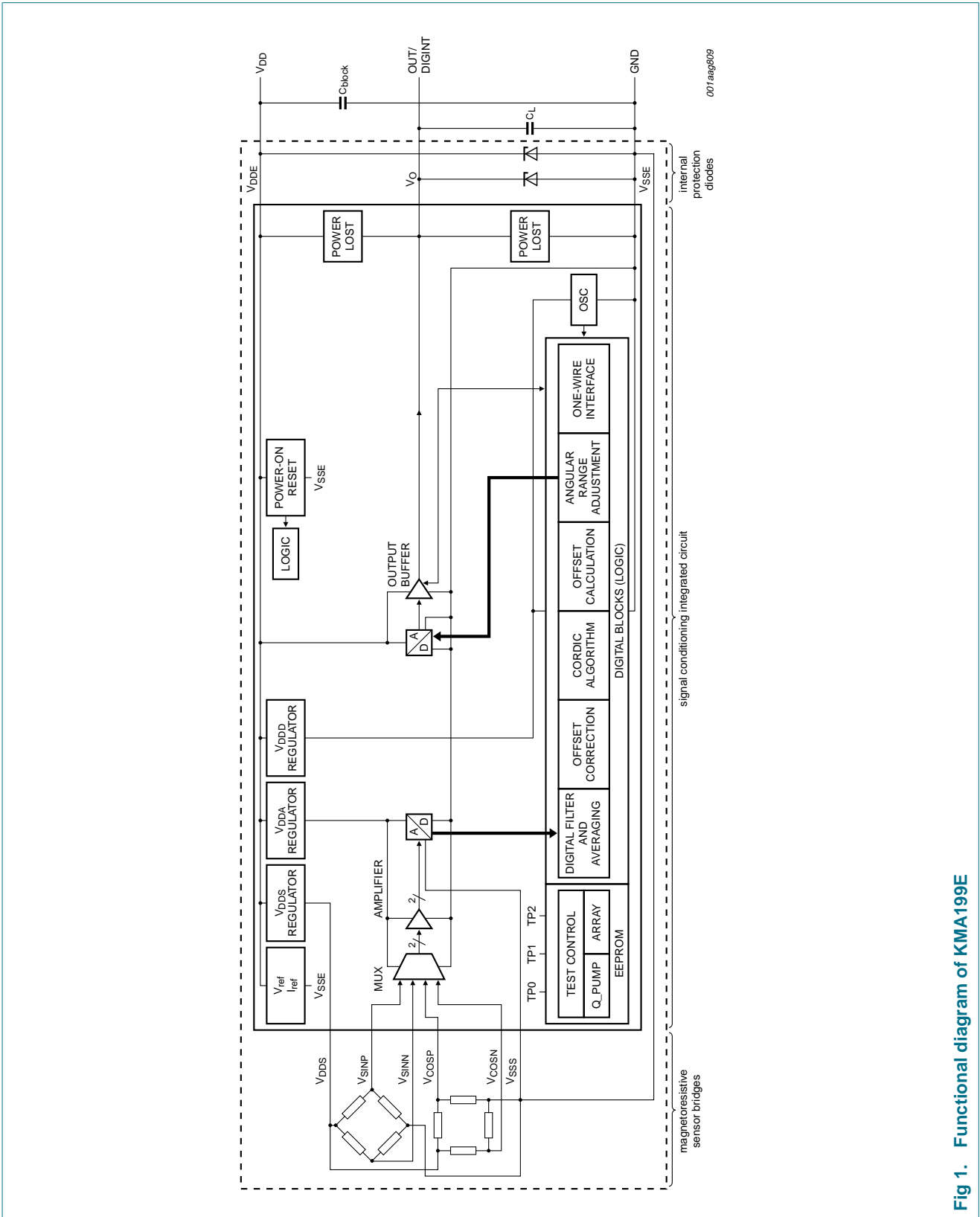

Fig 1. Functional diagram of KMA199E

5. Functional description

The KMA199E amplifies two orthogonal differential signals, which are delivered by MR sensor bridges and converts them into the digital domain. The angle is calculated using the COordinate Rotation DIgital Computer (CORDIC) algorithm. After a digital-to-analog conversion the analog signal is provided to the output. Thus, the output is a linear representation of the angular value. Zero angle, clamping voltages and angular range are programmable. In addition, two 16-bit registers are available for customer purposes, like sample identification.

The KMA199E comprises a Cyclic Redundancy Check (CRC) and an Error Detection and Correction (EDC) supervision, as well as a magnet-lost detection to ensure a fail-safe operation. A power-lost detection circuit pulls the analog output to the remaining supply line, if either the supply voltage or the ground line is interrupted.

After multiplexing the two MR Wheatstone bridge signals and their successive amplification, the signal is converted into the digital domain by an Analog-to-Digital Converter (ADC). Further processing is done within an on-chip state machine. This includes offset cancellation, calculation of the mechanical angle using the CORDIC algorithm, as well as zero angle and angular range adjustment. The internal Digital-to-Analog Converter (DAC) and the analog output stage are used for conversion of the angle information into an analog output voltage, which is ratiometric to the supply voltage.

The configuration parameters are stored in an user-programmable EEPROM. For this purpose the OWI, which is accessible via the pin OUT/DIGINT, is used.

5.1 Angular measurement directions

The differential signals of the MR sensor bridges depend only on the direction of the external magnetic field strength H_{ext} , which is applied parallel to the plane of the sensor. In order to obtain a correct output signal, the minimum saturation field strength has to be exceeded.

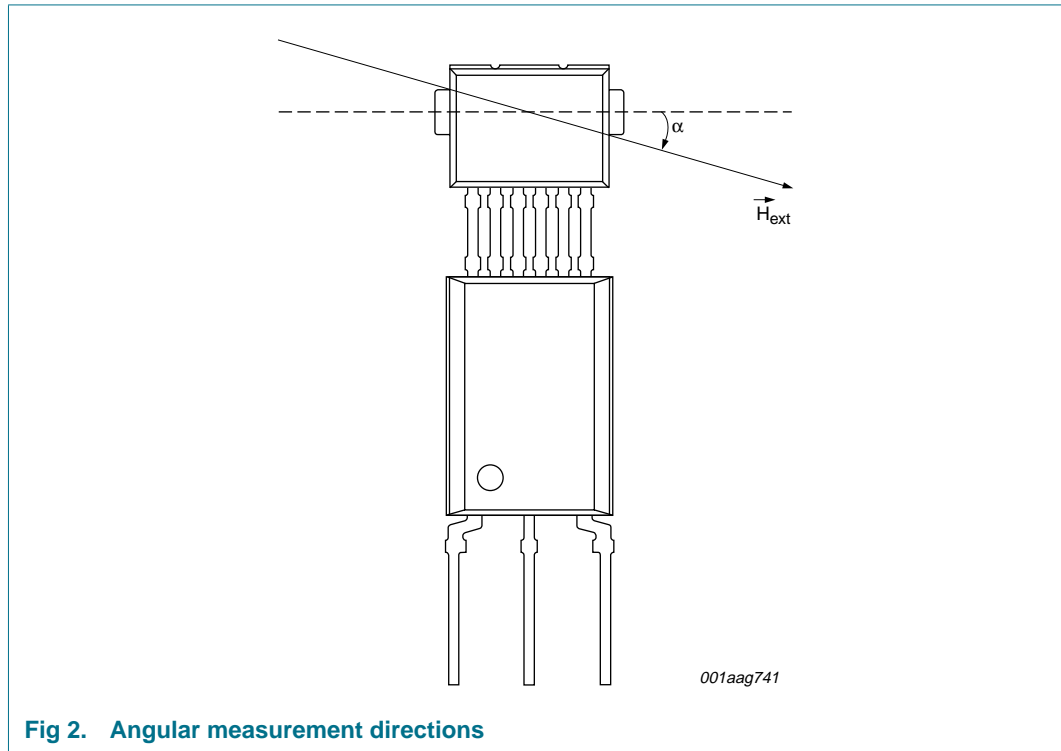

Fig 2. Angular measurement directions

Since the Anisotropic MR (AMR) effect is periodic over 180°, the sensor output is also 180°-periodic, whereas the angle is calculated relative to a freely programmable zero angle. The dashed line indicates the mechanical zero degree position.

6. Diagnostic features

The KMA199E provides four diagnostic features:

6.1 EEPROM CRC and EDC supervision

The KMA199E includes a supervision of the programmed data. At power-on, a CRC of the EEPROM is done. Furthermore the EEPROM is protected against bit errors. For this purpose every 16-bit data word is saved internally as a 22-bit word. The protection logic corrects any single-bit error in a data word, while the sensor continues in normal operation mode and can detect all double-bit errors by going into diagnostic mode.

6.2 Magnet-lost detection

If the applied magnetic field strength is not sufficient, the KMA199E raises a diagnostic condition. In order to enter the diagnostic mode, due to EEPROM CRC or magnet-lost detection, the device can be programmed for an active diagnostic mode, where the output is driven below 4 %V_{DD} or above 96 %V_{DD}.

6.3 Power-lost detection

The power-lost detection circuits enable the detection of an interrupted supply or ground line of the KMA199E. In case of a power-lost condition, two internal switches within the sensor are closed, connecting the pin of the analog output with the pins of the supply voltage and the ground.

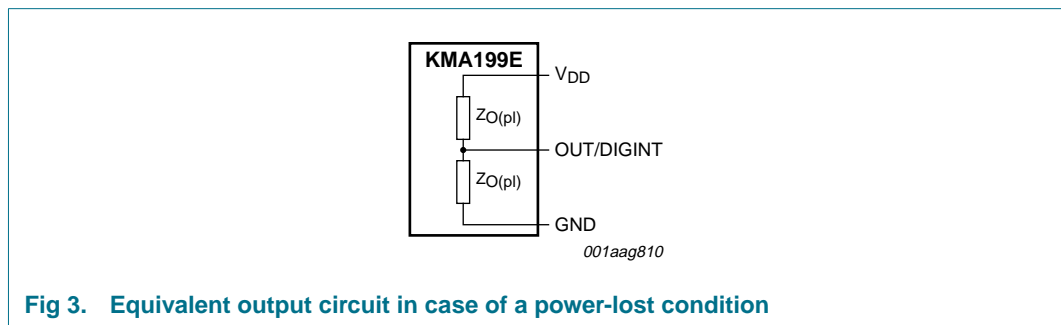

Fig 3. Equivalent output circuit in case of a power-lost condition

Table 3 shows the resulting output voltage depending on the error case and the load resistance.

Table 3. Power-lost behavior

Load resistance	Supply voltage lost	Ground lost
$R_L > 5 \text{ k}\Omega$	$V_O \leq 4 \%V_{DD}$	$V_O \geq 96 \%V_{DD}$

6.4 Low supply voltage detection

If the supply voltage is below the switch-off threshold voltage, a status bit is set.

Following table describes the behavior of the analog output at different supply voltages.

Table 4. Supply voltage behavior

Voltage range	Description	Analog output
0 V to $\approx 1.5 \text{ V}$	the output drives an active LOW, but the switches of the power-lost detection circuits are not fully opened and set the output to a level between ground and half the supply voltage	actively driven output to a voltage level between ground and half the supply voltage
$\approx 1.5 \text{ V}$ to V_{POR}	all modules begin to work and the power-on reset is active	diagnostics at LOW level
V_{POR} to $V_{th(on)}$ or $V_{th(off)}$	all modules begin to work and the digital part is initialized	EEPROM defined diagnostic level
$V_{th(on)}$ or $V_{th(off)}$ to 4.5 V	analog output is switched on after power-on time and represents the measured angle	analog output of the measured angle without the specified accuracy
4.5 V to 5.5 V	normal operation where the sensor works with the specified accuracy	analog output of the measured angle

7. Analog output

The KMA199E provides one analog output signal on pin OUT/DIGINT. The measured angle α is converted linearly into a value, which is ratiometric to the supply voltage V_{DD} . For this purpose either a positive or a negative slope is provided.

The following table describes the analog output behavior for a positive slope. If for example a magnetic field angle, larger than the programmed maximum angle α_{max} , but smaller than the clamp switch angle $\alpha_{sw(CL)}$ is applied to the sensor, the analog output is set to the upper clamping voltage. But if the magnetic field angle is even larger than the clamp switch angle, the analog output switches from upper to lower clamping voltage. In case of a negative slope, the clamping voltages are changed.

Table 5. Analog output behavior for a positive slope

Magnetic field angle	Analog output
$\alpha_{max} < \alpha < \alpha_{sw(CL)}$	$V_{(CL)u}$
$\alpha_{sw(CL)} < \alpha < \alpha_{ref} + 180^\circ$	$V_{(CL)l}$

The analog output voltage range codes both angular and diagnostic information. A valid value of the angle is between the upper and lower clamping voltage. If the analog output is in the diagnostic range, that is below 4 % V_{DD} or above 96 % V_{DD} , an error condition has been detected. The analog output repeats every 180°.

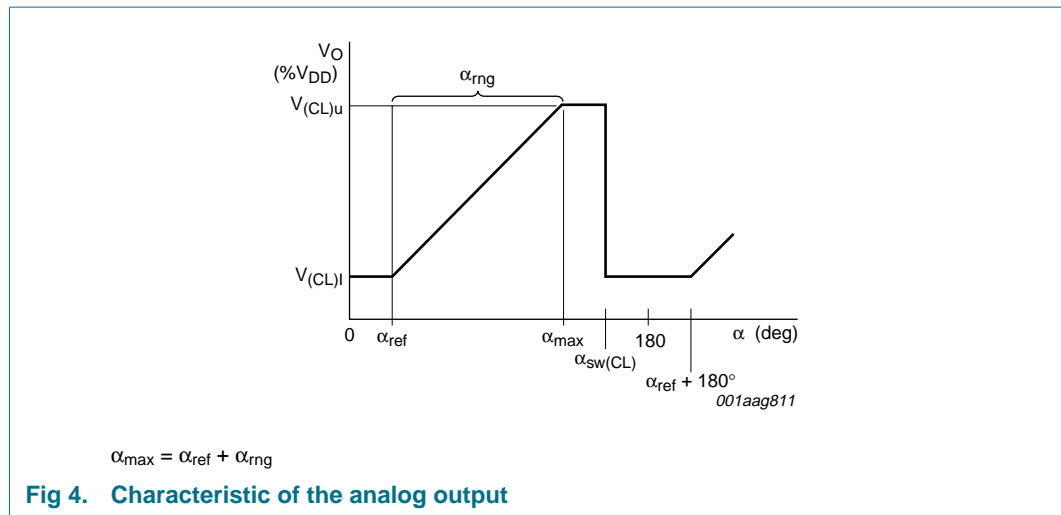

8. Limiting values

Table 6. Limiting values

In accordance with the Absolute Maximum Rating System (IEC 60134).

Symbol	Parameter	Conditions	Min	Max	Unit
V _{DD}	supply voltage		-0.3	+5.7	V
		t _{init} < 200 h	[1] -	6.0	V
V _O	output voltage		[2] -0.3	V _{DD} + 0.3	V
I _r	reverse current	T _{amb} < 70 °C	-	150	mA
T _{amb}	ambient temperature		-40	+160	°C
T _{amb(pr)}	programming ambient temperature		10	70	°C
T _{stg}	storage temperature		-40	+125	°C
EEPROM					
t _{ret(D)}	data retention time	T _{amb} = 50 °C	17	-	year
N _{endu(W_ER)}	write or erase endurance	T _{amb(pr)} = 70 °C	100	-	cycle

[1] Time until sensor environment is initialized.

[2] The maximum value of the output voltage is 5.7 V.

9. Recommended operating conditions

Table 7. Operating conditions

In a homogenous magnetic field.

Symbol	Parameter	Conditions	Min	Typ	Max	Unit
V _{DD}	supply voltage		[1] 4.5	5.0	5.5	V
T _{amb}	ambient temperature		-40	-	+160	°C
T _{amb(pr)}	programming ambient temperature		10	-	70	°C
C _L	load capacitance		[2] 0.33	-	22	nF
C _{block}	blocking capacitance		[3] 75	100	-	nF
R _L	load resistance		[4] 5	-	∞	kΩ
H _{ext}	external magnetic field strength		35	-	-	kA/m

[1] Normal operation mode.

[2] Between ground and analog output, as close as possible to the package.

[3] Between ground and supply voltage, as close as possible to the package and with a low equivalent series resistance.

[4] Power-lost detection is only possible with a load resistance within the specified range.

10. Thermal characteristics

Table 8. Thermal characteristics

Symbol	Parameter	Conditions	Typ	Unit
R _{th(j-a)}	thermal resistance from junction to ambient		120	K/W

11. Characteristics

Table 9. Supply current

Characteristics are valid for the operating conditions, as specified in [Section 9](#).

Symbol	Parameter	Conditions	Min	Typ	Max	Unit
I_{DD}	supply current		[1][2] -	-	10	mA

[1] Normal operation mode.

[2] Without load current at the analog output.

Table 10. Power-on reset

Characteristics are valid for the operating conditions, as specified in [Section 9](#).

Symbol	Parameter	Conditions	Min	Typ	Max	Unit
$V_{th(on)}$	switch-on threshold voltage	analog output switches on, if $V_{DD} > V_{th(on)}$	4.20	4.30	4.49	V
$V_{th(off)}$	switch-off threshold voltage	analog output switches off, if $V_{DD} < V_{th(off)}$	-	4.20	4.30	V
V_{hys}	hysteresis voltage	$V_{hys} = V_{th(on)} - V_{th(off)}$	0.1	-	0.4	V
V_{POR}	power-on reset voltage	IC is initialized	2.4	-	3.3	V

Table 11. System performance

Characteristics are valid for the operating conditions, as specified in [Section 9](#).

Symbol	Parameter	Conditions	Min	Typ	Max	Unit
α_{res}	angle resolution		[1] -	-	0.04	deg
α_{max}	maximum angle	programmable angular range for $V_{(CL)u} - V_{(CL)l} \geq 80\%V_{DD}$	[2] 5	-	180	deg
α_{ref}	reference angle	programmable zero angle	[2] 0	-	180	deg
$V_{O(nom)}$	nominal output voltage	at full supply operating range	5	-	95	% V_{DD}
$V_{O(udr)}$	upper diagnostic range output voltage		[3] 96	-	100	% V_{DD}
$V_{O(ldr)}$	lower diagnostic range output voltage		[3] 0	-	4	% V_{DD}
$V_{(CL)u}$	upper clamping voltage		[4] 40	-	95	% V_{DD}
$V_{(CL)l}$	lower clamping voltage		[4] 5	-	30.5	% V_{DD}
$\Delta V_{(CL)}$	clamping voltage variation	deviation from programmed value	-0.3	-	+0.3	% V_{DD}
I_O	output current	normal operation mode; operating as sink or source	-	-	2	mA
$V_{n(o)(RMS)}$	RMS output noise voltage	equivalent power noise	[5] -	0.4	2.5	mV
$\Delta\phi_{lin}$	linearity error		[5][6] -1.55	-	+1.55	deg
$\Delta\phi_{temp}$	temperature drift error		[1][5][6] -	-	0.8	deg
$\Delta\phi_{temp RT}$	temperature drift error at room temperature		[7][8]	-	0.55	deg

Table 11. System performance ...continued

Characteristics are valid for the operating conditions, as specified in [Section 9](#).

Symbol	Parameter	Conditions	Min	Typ	Max	Unit
$\Delta\phi_{\text{hys}}$	hysteresis error	referred to input	[5][6]	-	0.09	deg
$\Delta\phi_{\mu\text{lin}}$	microlinearity error	referred to input	[5][6]	-0.1	+0.1	deg
$Z_{O(\text{pl})}$	power-lost output impedance	impedance to remaining supply line in case of lost supply voltage or lost ground	-	-	210	Ω

[1] At a nominal output voltage between 5 % V_{DD} and 95 % V_{DD} and a maximum angle of $\alpha_{\text{max}} = 180^\circ$.

[2] In steps of resolution < 0.022°.

[3] Activation is dependent on the programmed diagnostic mode.

[4] In steps of 0.02 % V_{DD} .

[5] At a low-pass filtered analog output with a cut-off frequency of 0.7 kHz.

[6] See [Section 12](#).

[7] Temperature range -40 °C to +140 °C.

[8] Based on a 3 σ standard deviation.

Table 12. Dynamics

Characteristics are valid for the operating conditions, as specified in [Section 9](#).

Symbol	Parameter	Conditions	Min	Typ	Max	Unit
t_{on}	turn-on time	until first valid result	-	-	5	ms
f_{upd}	update frequency		2	3.125	-	kHz
t_{s}	settling time	after an ideal mechanical angle step of 45°, until 90 % of the final value is reached; $C_{\text{L}} = 5 \text{ nF}$	-	-	1.8	ms
$t_{\text{cmd}(\text{ent})}$	enter command mode time	after power on	16	-	26	ms

Table 13. Digital interface

Characteristics are valid for the operating conditions, as specified in [Section 9](#).

Symbol	Parameter	Conditions	Min	Typ	Max	Unit
V_{IH}	HIGH-level input voltage		80	-	-	% V_{DD}
V_{IL}	LOW-level input voltage		-	-	20	% V_{DD}
V_{OH}	HIGH-level output voltage	$I_{\text{O}} = 2 \text{ mA}$	80	-	-	% V_{DD}
V_{OL}	LOW-level output voltage	$I_{\text{O}} = 2 \text{ mA}$	-	-	20	% V_{DD}
I_{od}	overdrive current	absolute value for overdriving the output buffer	-	-	20	mA
t_{start}	start time	LOW level before rising edge	5	-	-	μs
t_{stop}	stop time	HIGH level before falling edge	5	-	-	μs
T_{bit}	bit period	minimum period may be limited by the load capacitance	10	-	100	μs
t_{w0}	pulse width 0		$0.175T_{\text{bit}}$	$0.25T_{\text{bit}}$	$0.375T_{\text{bit}}$	s
t_{w1}	pulse width 1		$0.625T_{\text{bit}}$	$0.75T_{\text{bit}}$	$0.825T_{\text{bit}}$	s
t_{to}	time-out time	digital communication reset guaranteed after maximum t_{to}	-	-	220	μs

Table 13. Digital interface ...continued

Characteristics are valid for the operating conditions, as specified in [Section 9](#).

Symbol	Parameter	Conditions	Min	Typ	Max	Unit
ΔT_{bit}	bit period deviation	deviation between received clock and sent clock	$0.8T_{\text{bit}}$	$1T_{\text{bit}}$	$1.2T_{\text{bit}}$	s
$t_{\text{tko(slv)}}$	slave takeover time	duration of LOW level for slave takeover	1	-	5	μs
$t_{\text{tko(mas)}}$	master takeover time	duration of LOW level for master takeover	$0T_{\text{bit}}$	-	$0.5T_{\text{bit}}$	s
t_{prog}	programming time	for a single EEPROM address	20	-	-	ms
t_{cp}	charge pump time	waiting time after enabling the EEPROM charge pump clock	1	-	-	ms

12. Definition of errors

12.1 General

Angular measurement errors by the KMA199E result from linearity errors, temperature drift errors and hysteresis errors. [Figure 5](#) shows the output signal of an ideal sensor, where the measured angle ϕ_{meas} corresponds ideally to the magnetic field angle α . This curve will further be denoted as angle reference line $\phi_{\text{ref}}(\alpha)$ with a slope of $0.5\%V_{\text{DD}}/\text{deg}$.

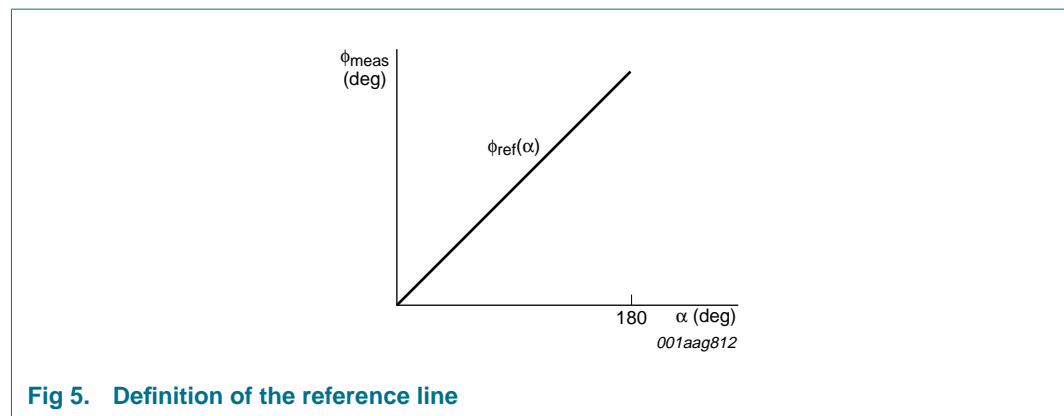
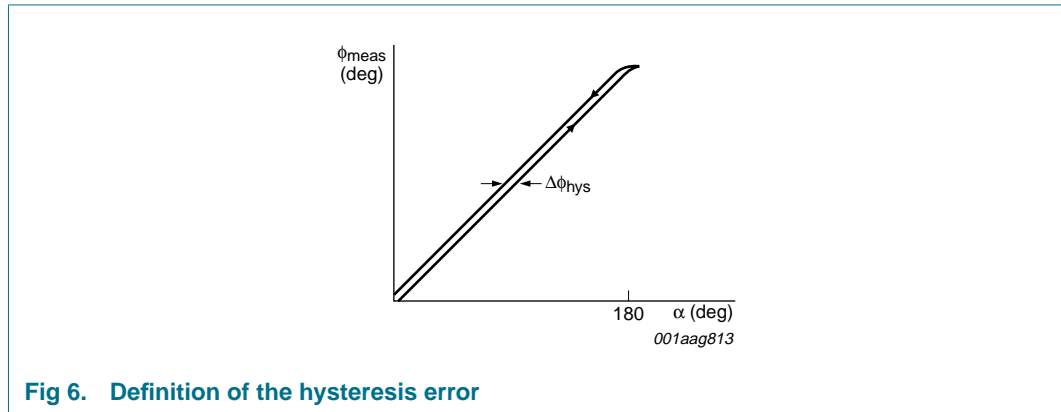

Fig 5. Definition of the reference line

For valid definition of errors, the angular range is set to $\alpha_{\text{max}} = 180^\circ$ and the clamping voltages are programmed to $V_{(\text{CL})\text{L}} = 5\%V_{\text{DD}}$ and $V_{(\text{CL})\text{H}} = 95\%V_{\text{DD}}$.

12.2 Hysteresis error

The hysteresis error $\Delta\phi_{\text{hys}}$ is defined as the maximum difference between angles, given by the device output when performing a positive (clockwise) rotation and negative (counter clockwise) rotation over an angular range of 180° , measured at a constant temperature.



12.3 Linearity error

The deviation of the KMA199E output signal from a best straight line ϕ_{BSL} , with the same slope as the reference line, is defined as linearity error. For measurement of this linearity error, the magnetic field angle is varied at fixed temperatures. The deviation of the output signal from the best straight line at the given temperature is the linearity error $\Delta\phi_{lin}$. It is a function of the magnetic field angle α and the temperature of the device T_{amb} .

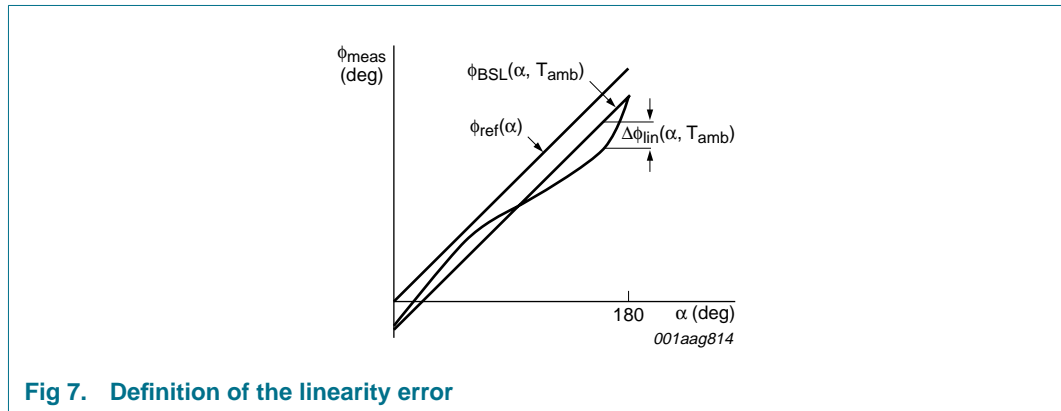

12.4 Microlinearity error

The microlinearity error $\Delta\phi_{\mu lin}$ is the deviation of the device output from 1° , if the magnetic field angle α is changed by $\Delta\alpha = 1^\circ$.

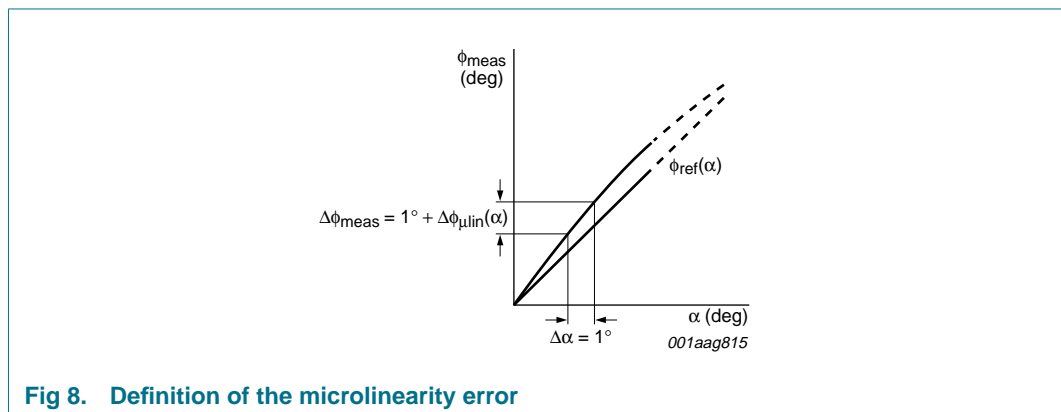

12.5 Temperature drift error

The temperature drift $\Delta\phi_{temp}$ is defined as the envelope over the deviation of the angle versus the temperature range. It is considered as the pure thermal effect.

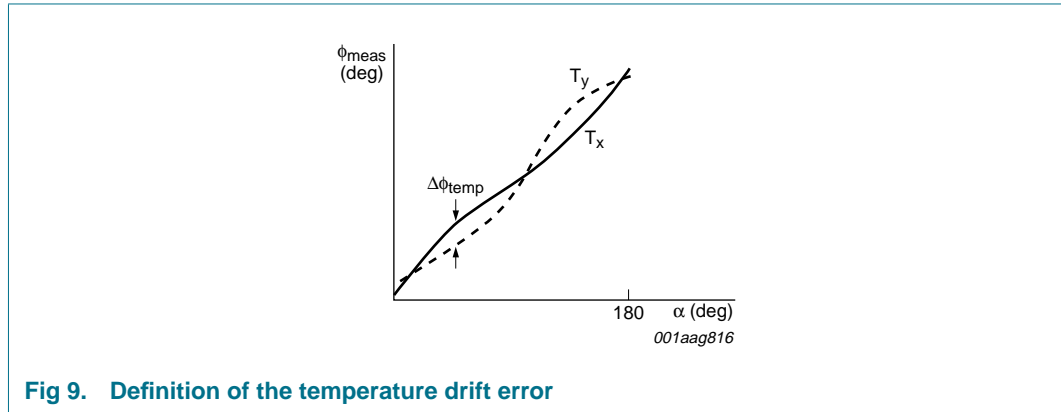

Fig 9. Definition of the temperature drift error

Following mathematical description is given for temperature drift value $\Delta\phi_{temp}$:

$$\Delta\phi_{temp}(\alpha) = |\phi_{meas}(\alpha, T_x) - \phi_{meas}(\alpha, T_y)| \tag{1}$$

with:

T_x : temperature for maximum ϕ_{meas} at angle α

T_y : temperature for minimum ϕ_{meas} at angle α

The deviation from the value at room temperature $\Delta\phi_{temp|RT}$ describes the temperature drift of the angle, compared to the value, which the sensor provides at room temperature:

$$\Delta\phi_{temp|RT}(\alpha, T_{amb}) = |\phi_{meas}(\alpha, T_{amb}) - \phi_{meas}(\alpha, T_{RT})| \tag{2}$$

with:

T_{RT} : room temperature (25 °C)

13. Programming

13.1 General description

The KMA199E provides an OWI for programming. For this purpose the pin OUT/DIGINT can be used bidirectional.

In general the device runs in analog output mode, the normal operation mode, which is configured by the on-chip programmed data and will be started by default after a power-on reset and the time t_{on} . In this mode the magnetic field angle is converted into a corresponding output voltage.

For programming the command mode has to be entered. In this mode the customer can adjust all required parameters (like zero angle and angular range for example) to his own application. The data can be stored in the EEPROM, after enabling the internal charge pump and waiting for t_{cp} . After changing EEPROM constants, the checksum has to be recalculated and written (see [Section 13.4](#)).

In order to enter the command mode, a specific command sequence has to be sent after a power-on reset and during the time slot $t_{cmd(ent)}$. For this purpose the external source, which is used to send the command sequence, has to overdrive the output buffer of the KMA199E, hence it has to provide the current I_{od} .

During the communication, the KMA199E is always the slave and the external programming hardware is always the master. [Figure 10](#) illustrates the structure of the OWI data format.

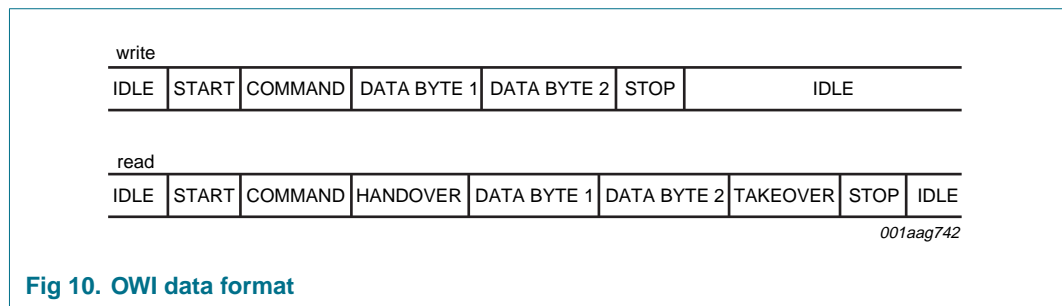

Fig 10. OWI data format

The master has to provide the start condition, which is a rising edge after a LOW level. Then a command byte is sent, which can be either a read or a write command. Depending on the command, the master or the slave has to send the data immediately after the command sequence. In case of a read command, an additional handover or takeover bit respectively is inserted before and after the data bytes. Each communication has to be closed with a stop condition driven by the master. If the slave gets no rising edge for a time longer than t_{to} , a time-out condition will be recognized. Then the bus is reset to the idle state and waits for a start condition and a new command. This can be used to synchronize the device regardless of the state before.

All communications are based on this structure (see [Figure 10](#)), even for entering the command mode. In this case a special write command is required, followed by the command sequence (two data bytes). The customer can access the EEPROM, the CTRL1, the TESTCTRL0 and the SIGNATURE register, which are described in [Section 13.5](#). Only a power-on reset will leave the command mode. A more detailed description of the programming is given in the next sections.

13.2 Timing characteristics

As described in the previous section, a start and stop condition is necessary for communication. The duration of the LOW level before the rising edge of the start condition is defined as t_{start} and the duration of the HIGH level after the rising edge of the stop condition is defined as t_{stop} . These parameters, as well as all other timing characteristics can be found in [Table 13](#).

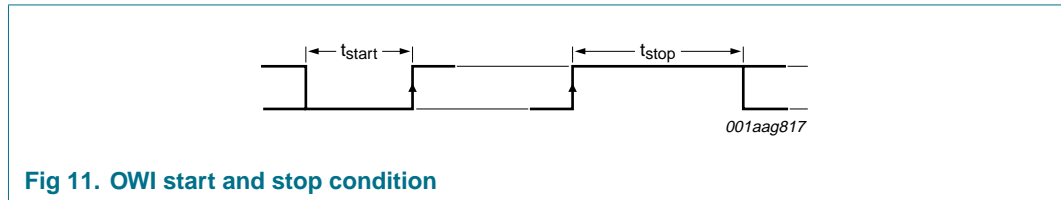
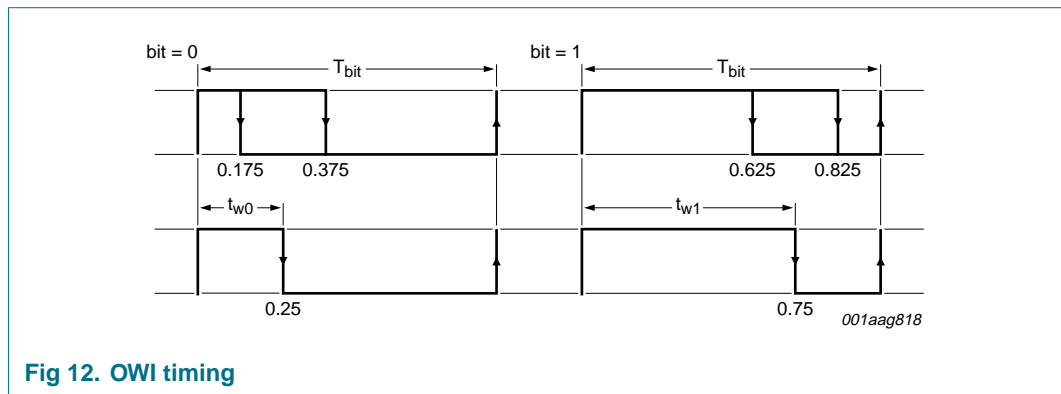

Fig 11. OWI start and stop condition

Figure 12 shows the coding of a single bit with a HIGH level of V_{IH} and a LOW level of V_{IL} . Here the pulse width t_1 or t_0 respectively represents a logic 1 or a logic 0 of a full bit period T_{bit} .



13.3 Sending and receiving data

For sending or receiving data, the master has to control the communication. The command byte defines the region, address and type of command, which is requested by the master, that is either a read or a write command. In case of a read command, an additional handover or takeover bit respectively has to be inserted before and after the two data bytes (see Figure 10). However the OWI is a serial data transmission, whereas the Most Significant Byte (MSB) must be sent at first.

Table 14. Format of a command byte

7	6	5	4	3	2	1	0
CMD7	CMD6	CMD5	CMD4	CMD3	CMD2	CMD1	CMD0

Table 15. Command byte bit description

Bit	Symbol	Description
7 to 5	CMD[7:5]	region bits 000 = 16-bit EEPROM 001 to 011 = reserved 100 = 16-bit register 101 to 111 = reserved
4 to 1	CMD[4:1]	address bits
0	CMD0	read/write 0 = write 1 = read

A more detailed description of all registers, that can be accessed by the customer, is given in [Section 13.5](#). Both default value and the complete command, which already includes the address and write or read request respectively, is listed there.

13.3.1 Write access

In order to write data into the EEPROM, the internal charge pump must be enabled at first by setting the bits `EEP_CP_CLOCK_EN` and `EEP_WRITE_EN` and waiting for t_{cp} . Afterwards the following procedure must be done:

- Start condition: The master drives a rising edge after a LOW level
- Command: The master sends a write command, that is the last bit is not set
- Data: The master sends two data bytes
- Stop condition: The master drives a rising edge after a LOW level

[Figure 13](#) shows the write access of the digital interface. The signal OWI represents the data on the bus, which is either caused by the master or by the slave. The signals master output enable and slave output enable just symbolize if the master or the slave output is enabled or disabled respectively.

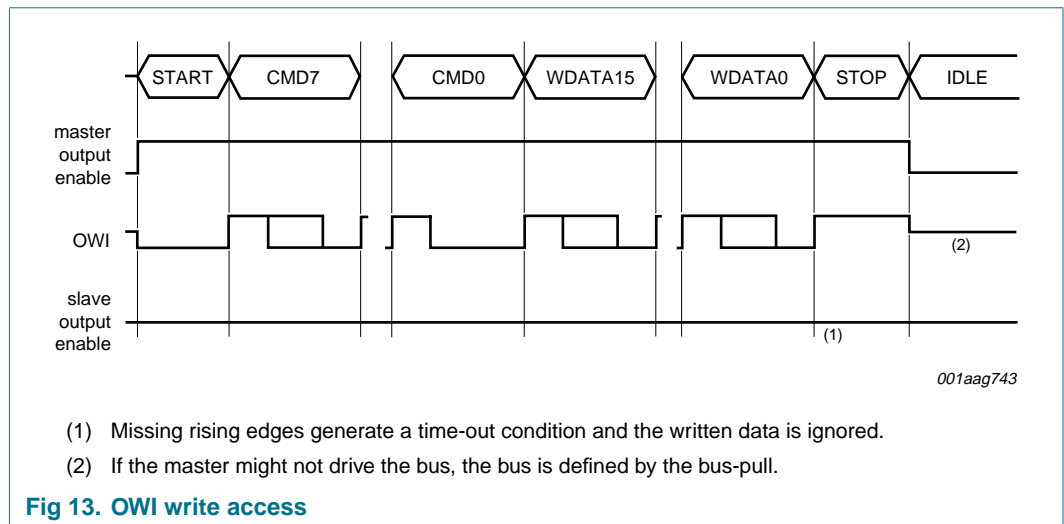

Note: As already mentioned in [Section 13.1](#), even the command mode has to be entered using the write procedure. Without entering the command mode a digital communication is not possible and the sensor would work in normal operation mode. After changing a single address the time t_{prog} must elapse before changing another address. Finally the checksum has to be recalculated and written, after changing the EEPROM constants (see [Section 13.4](#)).

13.3.2 Read access

In order to read data from the sensor, the following procedure must be done:

- Start condition: The master drives a rising edge after a LOW level
- Command: The master sends a read command, that is the last bit is set
- Handover: The master sends a handover bit, that is a logic 0 and disables his output after a three-quarter bit period
- Takeover: The slave drives a LOW level after the falling edge for $t_{tko(slv)}$
- Data: The slave sends two data bytes
- Handover: The slave sends a handover bit, that is a logic 0 and disables his output after a three-quarter bit period
- Takeover: The master drives a LOW level after the falling edge for $t_{tko(mas)}$
- Stop condition: The master drives a rising edge after a LOW level

Figure 14 shows the read access of the digital interface. The signal OWI represents the data on the bus, which is either caused by the master or by the slave. The signals master output enable and slave output enable just symbolize if the master or the slave output is enabled or disabled respectively.

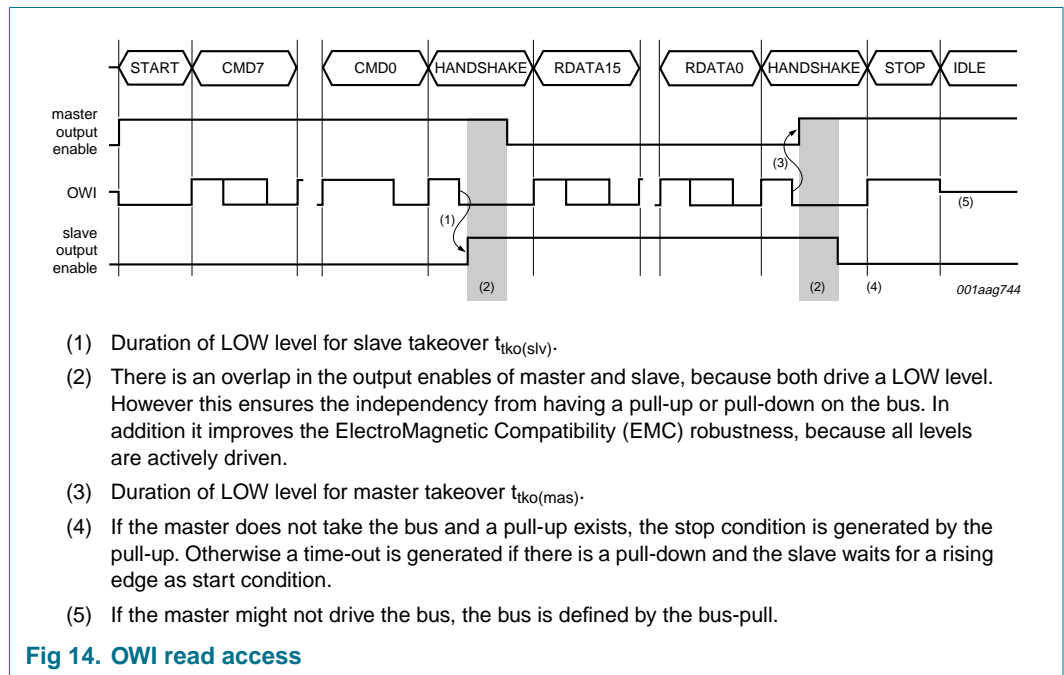

13.3.3 Entering the command mode

After a power-on reset, the sensor provides a time slot $t_{cmd(ent)}$ for entering the command mode. For this purpose a specific command sequence has to be sent (see [Figure 15](#)). Without entering the command mode, the sensor starts in normal operation mode. However the signature can always be written by the master, if the sensor switches into diagnostic mode.

During the command mode sequence, the analog output is enabled, hence the external programming hardware has to overdrive the output with the current I_{od} . If the command mode is activated, the analog output will be disabled and the pin OUT/DIGINT works as a digital interface.

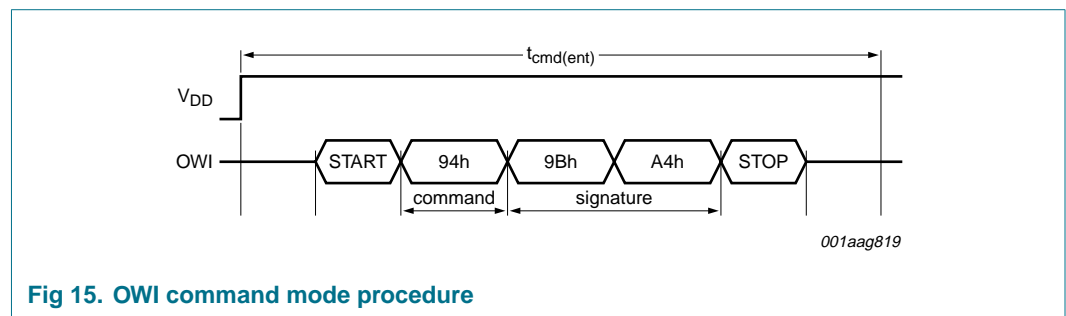

Fig 15. OWI command mode procedure

13.4 Cyclic redundancy check

As already mentioned in [Section 6](#), there is an 8-bit checksum of the EEPROM data. In order to calculate this value, a CRC has to be generated with the MSB of the EEPROM data word at first over all corresponding addresses in increasing order.

For calculating the checksum, all addresses from 0h to Fh have to be read out and consulted. The Least Significant Byte (LSB) of address Fh, which contains the previous checksum, must be overwritten with 0h before the calculation can be started.

Finally the internal charge pump has to be enabled for programming by setting the bits EEP_CP_CLOCK_EN and EEP_WRITE_EN (see [Table 16](#)) and waiting for t_{cp} .

The generator polynomial for the calculation of the checksum is:

$$G(x) = x^8 + x^2 + x + 1 \tag{3}$$

With a start value of FFh and the data bits are XOR at x^8 point.

13.4.1 Software example in C

```

1  #include <stdio.h.>
2
3  // calc_crc accepts unsigned 16-bit data in data
4  int calc_crc(int crc, unsigned int data)
5  {
6      const int gpoly = 0x107; // generator polynomial
7      int i; //index variable
8      for (i = 15; i >= 0; i--) {
9          crc <<= 1; //shift left
10         crc |= (int) ((data & (1u<<i))>>i);
11         // XOR of with generator polynomial when MSB(9) = HIGH
12         if (crc & 0x100) crc ^= gpoly;
13     }
14     return crc;
15 }
16 int main(void)
17 {
18     int crc, crc_res, i;
19     // 8 LSB are CRC field filled with 0
20     unsigned int data_seq[] = {0x1111, 0x2222, 0x3333, 0x4444,
21                               0x5555, 0x6666, 0x7777, 0x8888,
22                               0x9999, 0xAAAA, 0xBBBB, 0xCCCC,
23                               0xDDDD, 0xEEEE, 0xFFFF, 0x4200};
24     // calculate checksum over all data
25     crc = 0xFF; // start value of crc register
26     printf("Address\tValue\n");
27     for (i = 0; i <= 15; i++)
28     {
29         printf("0x%1X\t0x%04X\n", i, data_seq[i]);
30         crc = calc_crc(crc, data_seq[i]);
31     }
32     crc_res = crc; // crc_res = 0x6F
33     printf("\nChecksum\n0x%02X\n", crc_res);
34     // check procedure for above data sequence
35     crc = 0xFF;
36     for (i = 0; i <= 14; i++)
37         crc = calc_crc(crc, data_seq[i]);
38     // last word gets crc inserted
39     crc = calc_crc(crc, data_seq[i] | crc_res);
40     printf("\nCheck procedure for data sequence: must be 0x00 is 0x%02X.\n", crc);
41     return 1;
42 }

```

The checksum of this data sequence is 6Fh.

13.5 Registers

13.5.1 Command registers

In order to enter the command mode, the signature given in [Table 16](#) has to be written via the OWI into the specific register. This must be done as described in [Section 13.3.3](#), with a write command, followed by the signature, but after a power-on reset and not later than $t_{cmd(ent)}$.

Table 16. Command registers

Command write/read	Register	Bit	Access	Field	Description
82h/83h	CTRL1	15	R	IN_DIAG_MODE	shows if there is a diagnostic condition present; this bit is not affected by the setting of the register field FORCE_DIAG_OFF
		14	R/W	FORCE_DIAG_OFF	force diagnostic mode off; default: 0b
		13	-	-	reserved
		12	R	LOW_VOLTAGE_DET	low voltage condition detected
		11	R/W	EEP_CP_CLOCK_EN	charge pump clock on (must be set after setting EEPROM write enable signal for writing to EEPROM); default: 0b
		10 and 9	-	-	reserved
		8	R	EEP_ERR_CORRECT	EDC: EEPROM error has been corrected; updated every EEPROM readout and stays set once set
		7	R	EEP_UNCORR_ERR	EDC: EEPROM uncorrectable error has been detected; updated every EEPROM readout and stays set once set
		6	R	MAGNET_LOST_DET	magnet-lost detected; bit stays set even if the condition disappears; for this detection which leads to diagnostic mode, the magnet-lost detection must be enabled
		5	-	-	reserved
		4	R	CRC_BAD	CRC check has failed (checked during start-up)
		3 to 0	-	-	reserved
		94h/-	SIGNATURE	15 to 0	W
96h/97h	TESTCTRL0	15 to 12	-	-	reserved
		11	W	EEP_WRITE_EN	EEPROM write enable signal (must be set before writing to EEPROM) 0605h — disabled (default) 0E05h — enabled
		10 to 0	-	-	reserved

13.5.2 EEPROM registers

The device includes several internal registers, which are used for purposes, such as customization and identification.

The initial signature allows read access to all areas, but write access just to customer registers only. Write accesses to reserved areas are ignored. Since these registers are implemented as EEPROM cells, writing to the registers needs a specific time t_{prog} after each write access.

Since there is no check for the programming time, the user has to take care that no other access to the EEPROM is done during the programming. The EEPROM must not be addressed during the time t_{prog} .

Note: Before data can be stored in the EEPROM, the internal charge pump has to be switched on for the duration of programming by setting register CTRL1, bit 11 EEP_CP_CLOCK_EN, as well as register TESTCTRL0, bit 11 EEP_WRITE_EN. For calculating the checksum, all register addresses have to be read out and consulted, although some of them are reserved for calibration purposes.

Table 17. EEPROM registers

Address	Command write/read	Register	Bit	Description	Default MSB/LSB
0h	00h/01h	reserved	-	addresses are reserved for calibration purposes	[1]
1h	02h/03h			Note: These addresses have to be read out for calculating the checksum. The content stored in these registers may not be changed!	
2h	04h/05h				
3h	06h/07h				
4h	08h/09h				
5h	0Ah/0Bh				
6h	0Ch/0Dh				
7h	0Eh/0Fh	ZERO_ANGLE	15 to 0	mechanical zero degree position	00h/00h
8h	10h/11h	MAGNET_LOST	15 to 0	magnet-lost detection 0000h — disabled 004Fh — enabled	00h/00h
9h	12h/13h	ANG_RNG_MULT_LSB	15 to 3 2 to 0	least significant bits of angular range multiplier undefined ^[2]	20h/00h
Ah	14h/15h	CLAMP_LO	15 to 13 12 to 0	undefined ^[2] lower clamping level output voltage	01h/00h
Bh	16h/17h	CLAMP_HI	15 to 13 12 to 0	undefined ^[2] upper clamping level output voltage	12h/FFh
Ch	18h/19h	ID_LO	15 to 0	lower 16 bits of identification code	00h/00h
Dh	1Ah/1Bh	ID_HI	15 to 0	upper 16 bits of identification code	00h/00h
Eh	1Ch/1Dh	CLAMP_SW_ANGLE	15 to 6	when angle is bigger than CLAMP_SW_ANGLE the output will switch to CLAMP_LO for a positive slope	FFh/C1h
		ANG_RNG_MULT_MSB	5 to 0	most significant bits of angular range multiplier	

Table 17. EEPROM registers ...continued

Address	Command write/read	Register	Bit	Description	Default MSB/LSB
Fh	1Eh/1Fh	EEP_CTRL_CUST	15 and 14	undefined ^[2]	0Ch ^[1]
			13 and 12	DIAGNOSTIC_LEVEL; diagnostic level behavior of analog output 00 — active LOW (in lower diagnostic range) with driver strength of the analog output 01 — active HIGH (in upper diagnostic range) with driver strength of the analog output 10 — reserved 11 — reserved	
			11 and 10	reserved; may not be changed	
			9	undefined ^[2]	
			8	SLOPE_DIR; slope of analog output 0 — rising (not inverted) 1 — falling (inverted)	
			7 to 0	CRC; checksum over all data (see Section 13.4)	

[1] Variable and individual for each device.

[2] Undefined; must be written as zero for default.

Table 18. ZERO_ANGLE - mechanical zero degree position (address 7h) bit allocation

Data format: unsigned fixed point; resolution: 2⁻¹⁶.

Bit	15	14	13	12	11	10	9	8	7	6	5	4	3	2	1	0
Value	2 ⁻¹	2 ⁻²	2 ⁻³	2 ⁻⁴	2 ⁻⁵	2 ⁻⁶	2 ⁻⁷	2 ⁻⁸	2 ⁻⁹	2 ⁻¹⁰	2 ⁻¹¹	2 ⁻¹²	2 ⁻¹³	2 ⁻¹⁴	2 ⁻¹⁵	2 ⁻¹⁶

Mechanical angular range 0000h = 0° to FFFFh = 180° – 1 LSB

Examples:

- Mechanical zero angle 0° = 0000h
- Mechanical zero angle 10° = 0E38h
- Mechanical zero angle 45° = 4000h

Table 19. ANG_RNG_MULT_LSB - least significant bits of angular range multiplier (address 9h) bit allocation

Data format: unsigned fixed point; resolution: 2⁻¹⁴.

Bit	15	14	13	12	11	10	9	8	7	6	5	4	3	2	1	0
Value	2 ⁻²	2 ⁻³	2 ⁻⁴	2 ⁻⁵	2 ⁻⁶	2 ⁻⁷	2 ⁻⁸	2 ⁻⁹	2 ⁻¹⁰	2 ⁻¹¹	2 ⁻¹²	2 ⁻¹³	2 ⁻¹⁴	U ^[1]	U ^[1]	U ^[1]

[1] Undefined; must be written as zero for default and may return any value when read.

$$ANG_RNG_MULT = \frac{CLAMP_HI - CLAMP_LO}{8192} \times \frac{180^\circ}{ANGULAR_RANGE} \tag{4}$$

Table 20. CLAMP_LO - lower clamping level output voltage (address Ah) bit allocation

Data format: integer (DAC values 256 to 4864); resolution: 2⁰.

Bit	15	14	13	12	11	10	9	8	7	6	5	4	3	2	1	0
Value	U ^[1]	U ^[1]	U ^[1]	2 ¹²	2 ¹¹	2 ¹⁰	2 ⁹	2 ⁸	2 ⁷	2 ⁶	2 ⁵	2 ⁴	2 ³	2 ²	2 ¹	2 ⁰

[1] Undefined; must be written as zero for default and may return any value when read.

Values 0 to 255 are reserved. It is not permitted to use such values.

Examples:

- 100 %V_{DD} = 5120 (reserved)
- 10 %V_{DD} = 512
- 5 %V_{DD} = 256

Table 21. CLAMP_HI - upper clamping level output voltage (address Bh) bit allocation

Data format: integer (DAC values 256 to 4864); resolution: 2⁰.

Bit	15	14	13	12	11	10	9	8	7	6	5	4	3	2	1	0
Value	U[1]	U[1]	U[1]	2 ¹²	2 ¹¹	2 ¹⁰	2 ⁹	2 ⁸	2 ⁷	2 ⁶	2 ⁵	2 ⁴	2 ³	2 ²	2 ¹	2 ⁰

[1] Undefined; must be written as zero for default and may return any value when read.

Values 4865 to 5120 are reserved. It is not permitted to use such values.

Examples:

- 100 %V_{DD} = 5120 (reserved)
- 95 %V_{DD} = 4864
- 90 %V_{DD} = 4608

Table 22. ANG_RNG_MULT_MSB - most significant bits of angular range multiplier (address Eh) bit allocation

Data format: unsigned fixed point.

Bit	15	14	13	12	11	10	9	8	7	6	5	4	3	2	1	0
Value	CLAMP_SW_ANGLE										2 ⁴	2 ³	2 ²	2 ¹	2 ⁰	2 ⁻¹

$$ANG_RNG_MULT = \frac{CLAMP_HI - CLAMP_LO}{8192} \times \frac{180^\circ}{ANGULAR_RANGE} \tag{5}$$

Examples:

- $ANG_RNG_MULT = \frac{4864 - 256}{8192} \times \frac{180^\circ}{180^\circ} = 0.5625$
- $ANG_RNG_MULT = \frac{4864 - 256}{8192} \times \frac{90^\circ}{180^\circ} = 1.125$

Table 23. CLAMP_SW_ANGLE - clamp switch angle (address Eh) bit allocation

Data format: unsigned fixed point.

Bit	15	14	13	12	11	10	9	8	7	6	5	4	3	2	1	0
Value	2 ⁻¹	2 ⁻²	2 ⁻³	2 ⁻⁴	2 ⁻⁵	2 ⁻⁶	2 ⁻⁷	2 ⁻⁸	2 ⁻⁹	2 ⁻¹⁰	ANG_RNG_MULT_MSB					

Mechanical angular range 0000h = 0° to 3FFh = 180° – 1 LSB.

$$CLAMP_SW_ANGLE = \frac{1}{2} \times \left(1 + \frac{CLAMP_HI - CLAMP_LO}{8192} \times \frac{1}{ANG_RNG_MULT} \right) \tag{6}$$

If the magnetic field angle is larger than the CLAMP_SW_ANGLE, the output will switch to CLAMP_LO for a positive slope. The value of CLAMP_SW_ANGLE can be calculated from other EEPROM constants, but must be programmed.

14. Electromagnetic compatibility

EMC is achieved by the KMA199E.

14.1 Emission (CISPR 25)

Tests according to CISPR 25 were fulfilled.

14.1.1 Conducted radio disturbance

Test of the device according to CISPR 25, chapter 11 (artificial network).

Class: 5.

14.1.2 Radiated radio disturbance

Test of the device according to CISPR 25, chapter 13 (anechoic chamber - component/module).

Class: 5 (without addition of 6 dB in FM band).

14.2 Radiated disturbances (ISO 11452-2, ISO 11452-4 and ISO 11452-5)

The common understanding of the requested function is that an effect is tolerated as described in [Table 24](#) during the disturbance. If the KMA199E operates in operation mode, the Radio Frequency (RF) noise will occur on the signal and supply line.

Table 24. Failure condition for radiated disturbances

Parameter	Comment	Min	Max	Unit
Variation of output signal in analog output mode	value measured relative to the output at test start	-	±0.9	%V _{DD}

14.2.1 Absorber lined shielded enclosure

Tests according to ISO 11452-2 were fulfilled.

Test levels:

- > 200 V/m 200 MHz to 400 MHz (step 10 MHz)
- > 200 V/m 400 MHz to 1 000 MHz (step 25 MHz)
- > 200 V/m 1 GHz to 10 GHz (step 100 MHz)

Modulation: Continuous Wave (CW); AM: 1 kHz, 80 %.

State: A.

14.2.2 Bulk-current injection

Tests according to ISO 11452-4 were fulfilled.

Test level: 200 mA with C_L = 1 nF.

State: A.

14.2.3 Strip line

Tests according to ISO 11452-5 were fulfilled.

Test level: 200 V/m with $C_L = 1 \text{ nF}$.

State: A.

In deviation of ISO 11452-5 the measurement must be taken up to 1 GHz.

14.2.4 Immunity against mobile phones

Tests according to ISO 11452-2 were fulfilled.

State: A.

Definition of Global System for Mobile Communications (GSM) signal:

- Pulse modulation: per GSM specification (217 Hz; 12.5 % duty cycle)
- Modulation grade: $\geq 60 \text{ dB}$
- Sweep: linear 800 MHz to 3 GHz (duration 10 s at 890 MHz, 940 MHz and 1.8 GHz band)
- Antenna polarization: vertical, horizontal
- Field strength: 200 V/m during on-time (calibration in CW)

In deviation of ISO 11452-2 a GSM signal (definition see above) instead of an AM signal was used.

14.3 Transients - pulses (ISO 7637-1 and ISO 7637-3)

The KMA199E is designed for a stabilized 5 V supply. To raise immunity against non-galvanic coupled transient pulses, protection diodes are implemented into the KMA199E.

For applications with disturbances by capacitive or inductive coupling on supply line or radiated disturbances an application circuit is recommended. Applications with this arrangement passed the EMC tests according to the product standard 1 (electrical transient transmission by capacitive or inductive coupling) and standard 3 (radiated disturbances).

The common understanding of the requested function is that an effect is tolerated as described in [Table 25](#) during the disturbance. Class C means that the device goes into reset or diagnostic mode and comes back after disturbances. If the KMA199E operates in normal operation mode, the test pulses are visible on the signal line. A protection circuit is used. The KMA199E is directly supplied with 5 V.

Table 25. Failure condition for transients

Parameter	Comment	Min	Max	Unit
Variation of output signal after exposure to pulses in analog output mode	value measured relative to the output at test start	-	± 0.9	%V _{DD}

14.3.1 Coupled

Tests according to ISO 7637-3 were fulfilled.

Level of pulses: IV (-60 V for pulse 3a and +40 V for pulse 3b).

Class: B for pulse 3a, B for pulse 3b.

Test time: 10 min.

Transient transmission by capacitive and inductive coupling via lines other than supply lines (interface, analog output) have to be tolerated according to ISO 7637-3 (pulses 3a and 3b).

15. ElectroStatic Discharge (ESD)

To raise immunity against ESD pulses, protection diodes are implemented into the KMA199E.

15.1 Human body model

The KMA199E must not be damaged at 8 kV, according to the human body model at 100 pF and 1.5 kΩ. The test is according to AEC-Q100, Rev-E, method 002. This protection must be ensured at all external pins (OUT/DIGINT, V_{DD} and GND).

Furthermore all interconnects (pins between package head and package body) must not be damaged at 2 kV, according to AEC-Q100, Rev-E, method 002.

15.2 Machine model

The KMA199E must not be damaged at 400 V, according to the machine model. The test is according to AEC-Q100, Rev-E, method 003. This protection must be ensured at all external pins (OUT/DIGINT, V_{DD} and GND).

Furthermore all interconnects (pins between package head and package body) must not be damaged at 200 V, according to AEC-Q100, Rev-E, method 003.

All pins have a latch-up protection.

16. Application information

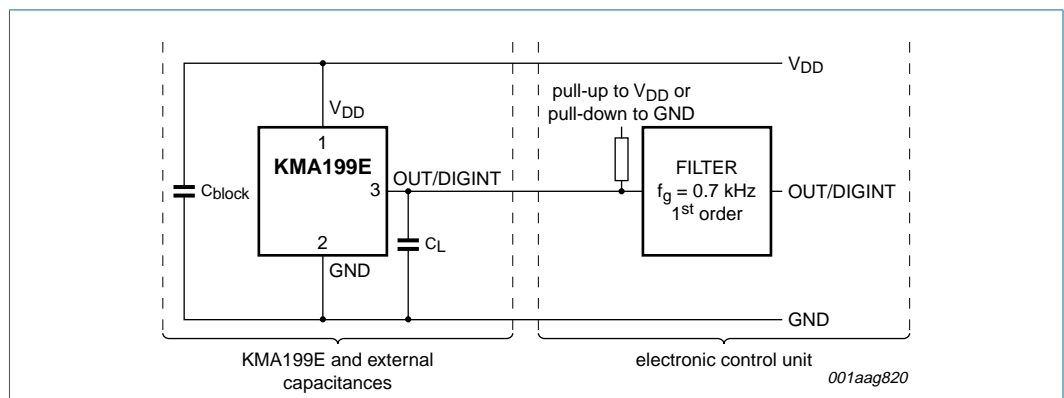

(1) The block capacitance C_{block} is used to suppress noise on the supply line of the device. For best functionality, the capacitances should be mounted close to the pins of the device.

Fig 16. Application diagram of KMA199E

17. Marking

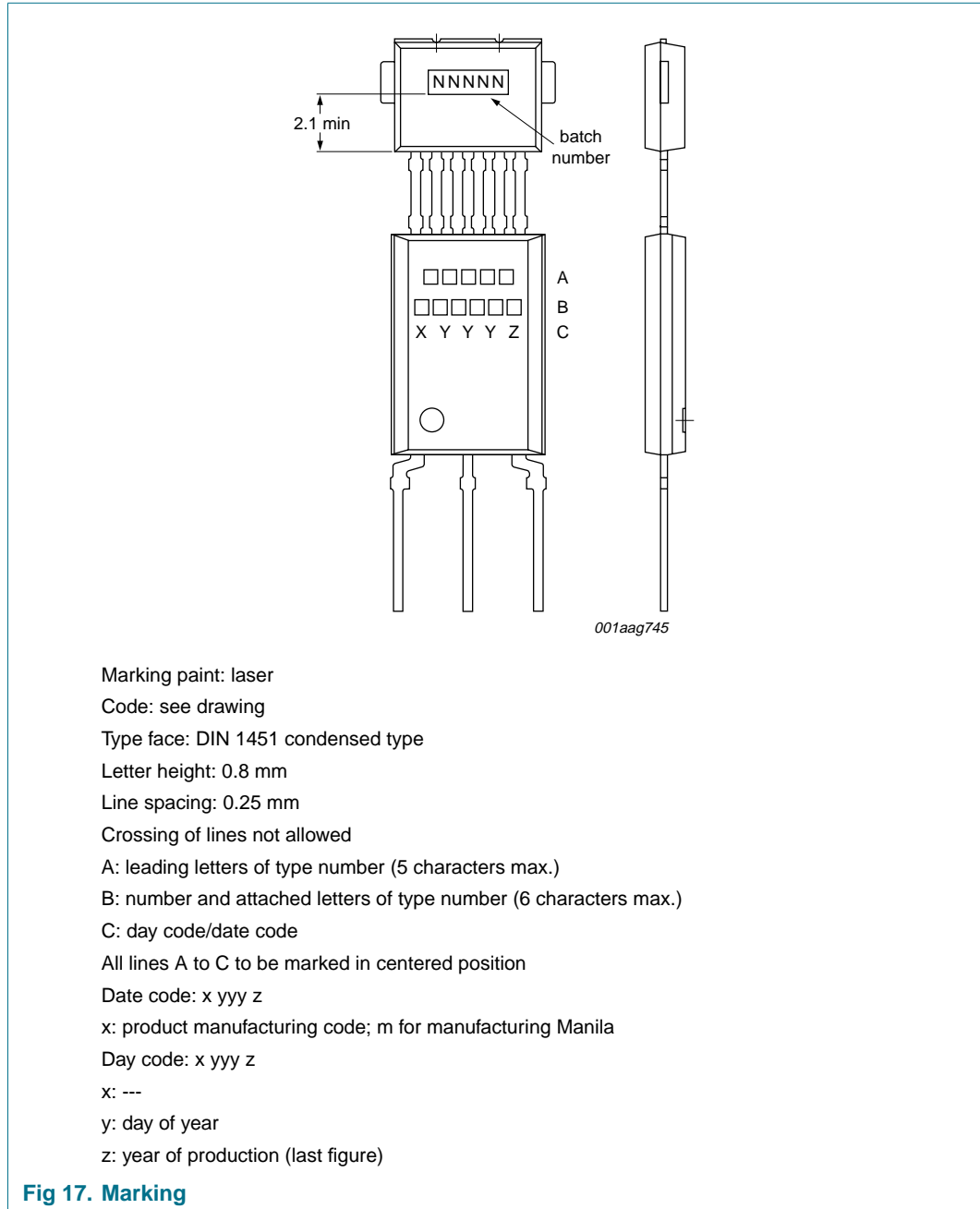

18. Terminals

Lead frame material: CuZr with 99.9 % Cu and 0.1 % Zr

Lead finish: matt tin; thickness 8 μm to 13 μm

19. Package outline

Plastic single-ended multi-chip package; 6 interconnections; 3 in-line leads

SOT880

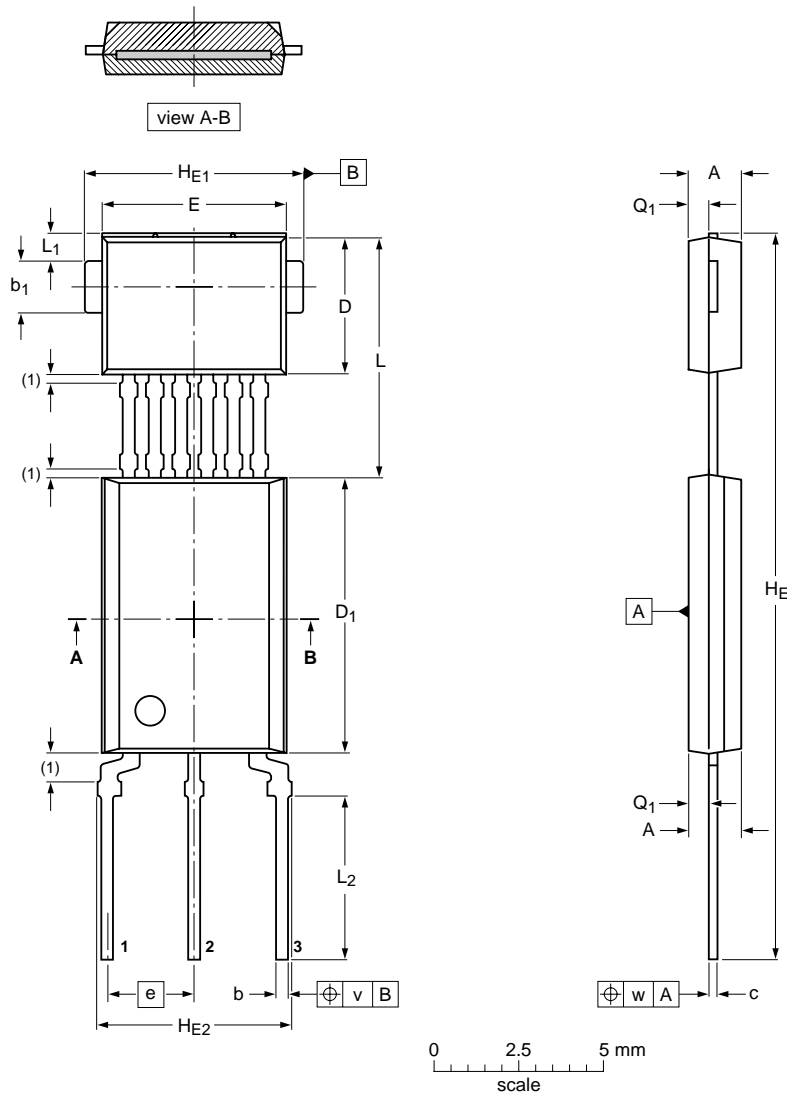

DIMENSIONS (mm are the original dimensions)

UNIT	A	b	b ₁	c	D	D ₁	E	e	H _E	H _{E1}	H _{E2} max	L	L ₁	L ₂ min	Q ₁	v	w
mm	1.65 1.45	0.41 0.34	1.57 1.47	0.30 0.24	4.1 3.9	8.1 7.9	5.45 5.25	2.54	21.4 21.0	6.42 6.32	5.85	7.1 6.9	0.85 0.75	4.75	0.65 0.55	0.4	1.2

Note

1. Terminals within this zone are uncontrolled to allow for flow of plastic between and besides the leads.

OUTLINE VERSION	REFERENCES			EUROPEAN PROJECTION	ISSUE DATE
	IEC	JEDEC	JEITA		
SOT880					07-09-03 07-09-11

Fig 18. Package outline SOT880

20. Handling information

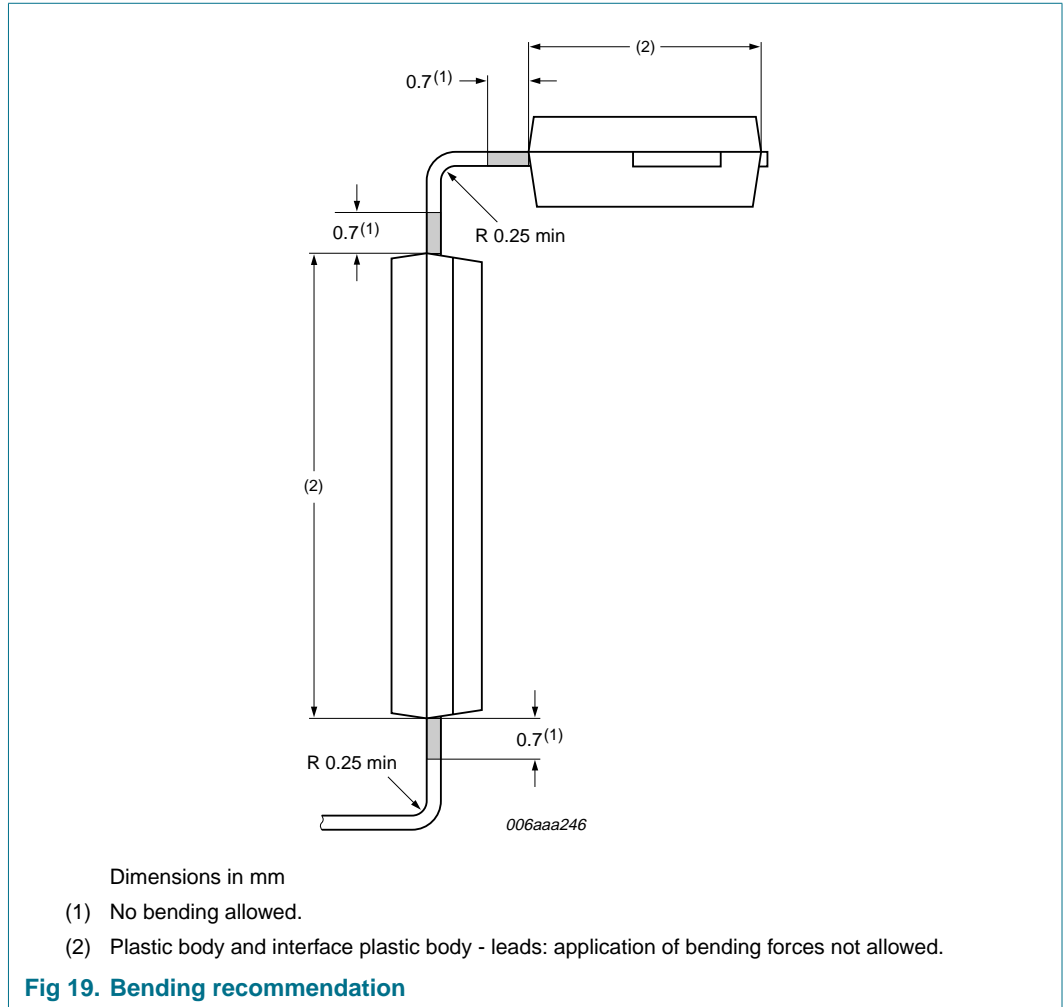

21. Solderability information

The solderability qualification is done according to AEC-Q100, Rev-E. Recommended soldering process for leaded devices is wave soldering. The maximum soldering temperature is 260 °C for maximum 5 s. Device terminals shall be compatible with laser and electrical welding.

22. Revision history

Table 26. Revision history

Document ID	Release date	Data sheet status	Change notice	Supersedes
KMA199E_1	20071018	Product data sheet	-	-

23. Legal information

23.1 Data sheet status

Document status ^{[1][2]}	Product status ^[3]	Definition
Objective [short] data sheet	Development	This document contains data from the objective specification for product development.
Preliminary [short] data sheet	Qualification	This document contains data from the preliminary specification.
Product [short] data sheet	Production	This document contains the product specification.

[1] Please consult the most recently issued document before initiating or completing a design.

[2] The term 'short data sheet' is explained in section "Definitions".

[3] The product status of device(s) described in this document may have changed since this document was published and may differ in case of multiple devices. The latest product status information is available on the Internet at URL <http://www.nxp.com>.

23.2 Definitions

Draft — The document is a draft version only. The content is still under internal review and subject to formal approval, which may result in modifications or additions. NXP Semiconductors does not give any representations or warranties as to the accuracy or completeness of information included herein and shall have no liability for the consequences of use of such information.

Short data sheet — A short data sheet is an extract from a full data sheet with the same product type number(s) and title. A short data sheet is intended for quick reference only and should not be relied upon to contain detailed and full information. For detailed and full information see the relevant full data sheet, which is available on request via the local NXP Semiconductors sales office. In case of any inconsistency or conflict with the short data sheet, the full data sheet shall prevail.

23.3 Disclaimers

General — Information in this document is believed to be accurate and reliable. However, NXP Semiconductors does not give any representations or warranties, expressed or implied, as to the accuracy or completeness of such information and shall have no liability for the consequences of use of such information.

Right to make changes — NXP Semiconductors reserves the right to make changes to information published in this document, including without limitation specifications and product descriptions, at any time and without notice. This document supersedes and replaces all information supplied prior to the publication hereof.

Suitability for use — NXP Semiconductors products are not designed, authorized or warranted to be suitable for use in medical, military, aircraft, space or life support equipment, nor in applications where failure or

malfunction of a NXP Semiconductors product can reasonably be expected to result in personal injury, death or severe property or environmental damage. NXP Semiconductors accepts no liability for inclusion and/or use of NXP Semiconductors products in such equipment or applications and therefore such inclusion and/or use is at the customer's own risk.

Applications — Applications that are described herein for any of these products are for illustrative purposes only. NXP Semiconductors makes no representation or warranty that such applications will be suitable for the specified use without further testing or modification.

Limiting values — Stress above one or more limiting values (as defined in the Absolute Maximum Ratings System of IEC 60134) may cause permanent damage to the device. Limiting values are stress ratings only and operation of the device at these or any other conditions above those given in the Characteristics sections of this document is not implied. Exposure to limiting values for extended periods may affect device reliability.

Terms and conditions of sale — NXP Semiconductors products are sold subject to the general terms and conditions of commercial sale, as published at <http://www.nxp.com/profile/terms>, including those pertaining to warranty, intellectual property rights infringement and limitation of liability, unless explicitly otherwise agreed to in writing by NXP Semiconductors. In case of any inconsistency or conflict between information in this document and such terms and conditions, the latter will prevail.

No offer to sell or license — Nothing in this document may be interpreted or construed as an offer to sell products that is open for acceptance or the grant, conveyance or implication of any license under any copyrights, patents or other industrial or intellectual property rights.

23.4 Trademarks

Notice: All referenced brands, product names, service names and trademarks are the property of their respective owners.

24. Contact information

For additional information, please visit: <http://www.nxp.com>

For sales office addresses, send an email to: salesaddresses@nxp.com

25. Contents

1	Product profile	1	14.2.4	Immunity against mobile phones	25
1.1	General description	1	14.3	Transients - pulses (ISO 7637-1 and	
1.2	Features	1		ISO 7637-3)	25
2	Pinning information	2	14.3.1	Coupled	25
3	Ordering information	2	15	ElectroStatic Discharge (ESD)	26
4	Functional diagram	3	15.1	Human body model	26
5	Functional description	4	15.2	Machine model	26
5.1	Angular measurement directions	4	16	Application information	26
6	Diagnostic features	5	17	Marking	27
6.1	EEPROM CRC and EDC supervision	5	18	Terminals	27
6.2	Magnet-lost detection	5	19	Package outline	28
6.3	Power-lost detection	6	20	Handling information	29
6.4	Low supply voltage detection	6	21	Solderability information	29
7	Analog output	7	22	Revision history	29
8	Limiting values	8	23	Legal information	30
9	Recommended operating conditions	8	23.1	Data sheet status	30
10	Thermal characteristics	8	23.2	Definitions	30
11	Characteristics	9	23.3	Disclaimers	30
12	Definition of errors	11	23.4	Trademarks	30
12.1	General	11	24	Contact information	30
12.2	Hysteresis error	11	25	Contents	31
12.3	Linearity error	12			
12.4	Microlinearity error	12			
12.5	Temperature drift error	13			
13	Programming	13			
13.1	General description	13			
13.2	Timing characteristics	14			
13.3	Sending and receiving data	15			
13.3.1	Write access	16			
13.3.2	Read access	17			
13.3.3	Entering the command mode	18			
13.4	Cyclic redundancy check	18			
13.4.1	Software example in C	19			
13.5	Registers	20			
13.5.1	Command registers	20			
13.5.2	EEPROM registers	21			
14	Electromagnetic compatibility	24			
14.1	Emission (CISPR 25)	24			
14.1.1	Conducted radio disturbance	24			
14.1.2	Radiated radio disturbance	24			
14.2	Radiated disturbances (ISO 11452-2,				
	ISO 11452-4 and ISO 11452-5)	24			
14.2.1	Absorber lined shielded enclosure	24			
14.2.2	Bulk-current injection	24			
14.2.3	Strip line	24			

Please be aware that important notices concerning this document and the product(s) described herein, have been included in section 'Legal information'.

