

**2.7W + 0.6W x 2 2.1 Channel CLASS-D AUDIO POWER AMPLIFIER**

**GENERAL DESCRIPTION**

The TMPA221DS is a 2.1 channel stereo & bass class-D audio power amplifier IC. It delivers up to 2.7W (bass) and 0.6W(right/left channel each) into 3 ohm loads. The bass output is designed as BTL (Bridge-Tied-Load) for high output power. The right & left channels are designed as SE (Single-Ended). The power efficiency can be up to 82% for 8 ohm load. No external heat-sink is required.

The internal de-pop circuitry eliminates pop noise at power-up & shutdown operations. Automatic power gain control makes the best use of battery.

Analog input signal is converted into digital output which drives directly the speaker. High power efficiency is achieved due to digital output at the load. The audio information is embedded in PWM( Pulse Width Modulation ).

**APPLICATIONS**

Multimedia application includes Cellular Phones, PDAs, DVD/CD players, 2.1 channel audio systems, USB audio. It is also ideal for other portable devices like Wireless Radios.

**REFERENCE CIRCUIT ( Please refer to TMPA002.APP for application )**

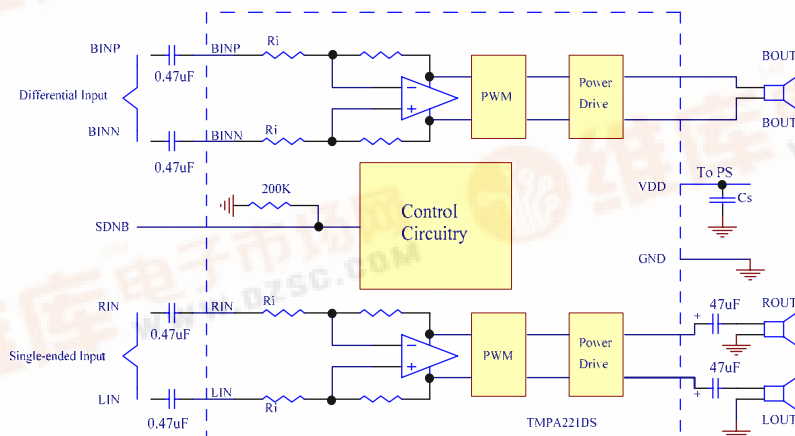

**FEATURES**

- ◆ 2.5V to 6V Single Supply
- ◆ Integrated 2.1 channel power amplifiers in one chip
- ◆ Up to 2.7W(bass)+0.6W(right/left Ch) at 5V, 3 ohms
- ◆ Up to 82% Power Efficiency
- ◆ Automatic output power control (APC)
- ◆ Total 4.4mA Quiescent Current at 5V
- ◆ Less Than 0.4uA Shutdown Current
- ◆ Pop-less Power-Up, Shutdown and Recovery
- ◆ Thermal Shutoff and Automatic Recovery
- ◆ Compatible with earphone application
- ◆ Output Pin Short-Circuit Protection (Short to Other Outputs, Short to VCC, Short to Ground)
- ◆ Differential Signal Processing Improves CMRR

**Package**

TSSOP20 Available, pb free 【RoHS】

For best performance, please refer to

<http://www.taiyec.com.tw/English/EVM.htm>

<http://www.class-d.com.tw/English/EVM.htm>

for PCB layout.



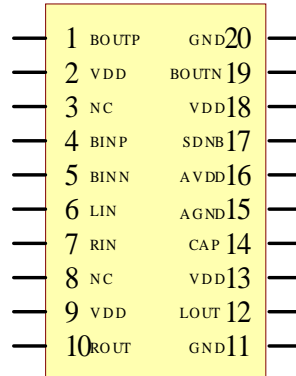

TMPA221DS

**( Please email david@taimec.com.tw for complete datasheet. )**

Tai-1 Microelectronics reserves the right to make corrections, modifications, enhancements, improvements, and other changes to its products and services at any time and to discontinue any product or service without notice. Customers are responsible for their products and applications using Tai-1 Microelectronics components.

Note that the external components or PCB layout should be designed not to generate abnormal voltages to the chip to prevent from latch up which may cause damage to the device.

## Typical Application

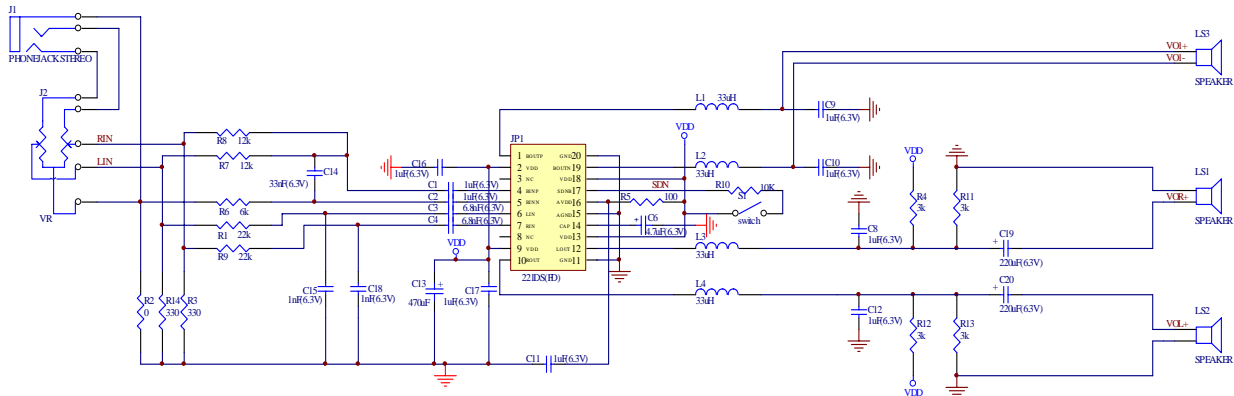

### ABSOLUTE MAXIMUM RATINGS

Over operating free-air temperature range unless otherwise noted(1)

Supply voltage, $V_{DD}$ , $AV_{DD}$	In normal mode	-0.3V to 6V	V
	In shutdown mode	-0.3V to 7V	V
Input voltage, $V_I$		-0.3V to $V_{DD}+0.3V$	V
Continuous total power dissipation	See package dissipation ratings		
Operating free-air temperature, $T_A$		-20 to 85	°C
Operating junction temperature, $T_J$		-20 to 150	°C
Storage temperature, $T_{stg}$		-40 to 150	°C

(1) Stresses beyond those listed under "absolute maximum ratings" may cause permanent damage to the device. These are stress ratings only, and functional operation of the device at these or any other conditions beyond those indicated under "recommended operating conditions" is not implied. Exposure to absolute-maximum-rated conditions for extended periods may affect device reliability.

### RECOMMENDED OPERATING CONDITONS

		MIN	NOM	MAX	UNIT
Supply voltage, $V_{DD}$ , $AV_{DD}$		2.5		6	V
High-level input voltage, $V_{IH}$	SDNB	2		$V_{DD}$	V
Low-level input voltage, $V_{IL}$	SDNB	0		0.8	V
Operating free-air temperature, $T_A$		-20		85	°C

### PACKAGE DISSIPATION RATINGS

PACKAGE	DERATING FACTOR	$T_A \leq 25^\circ\text{C}$ POWER RATING	$T_A = 70^\circ\text{C}$ POWER RATING	$T_A = 85^\circ\text{C}$ POWER RATING
TSSOP20	8.73 mW/°C	1.09W	698mW	567mW

### ELECTRICAL CHARACTERISTICS

$T_A=25^\circ\text{C}$  (unless otherwise noted)

PARAMETER	TEST CONDITIONS	MIN	TYP	MAX	UNIT
$V_{OS}$ Output offset voltage (measured differentially)	$V_I=0V, V_A=2, V_{DD}=AV_{DD}=2.5V$ to 5.5V		25		mV
PSRR Power supply rejection ratio	$V_{DD}=AV_{DD}=2.5V$ to 5.5V		-75	-55	dB
CMRR Common mode rejection ratio	$V_{DD}=AV_{DD}=2.5V$ to 5.5V, $V_{IC}=1V_{pp}$ , $R_L=8\Omega$		-55	-50	dB
$I_{IH}$ High-level input current	$V_{DD}=AV_{DD}=5.5V$ , $V_I=5.8V$ (SDNB)		30		$\mu\text{A}$
$I_{IL}$ Low-level input current	$V_{DD}=AV_{DD}=5.5V$ , $V_I=-0.3V$ (SDNB)			1	$\mu\text{A}$
$I_Q$ Quiescent current (total)	$V_{DD}=AV_{DD}=5V$ , no load		4.4	6	mA
$I_Q$ (SD) Shutdown current (total)	$V(\text{SDN})=0.8V$ , $V_{DD}=AV_{DD}=2.5V$ to 5.5V		0.4	1	$\mu\text{A}$
$r_{SD(on)}$ Static output resistance(BTL) Static output resistance(SE)	$V_{DD}=AV_{DD}=5.5V$		790		m $\Omega$
			550		
$f(\text{sw})$ Switching frequency	$V_{DD}=AV_{DD}=2.5V$ to 5.5V	230	280	330	kHz
* $A_v$ Voltage Gain(BTL and SE)	$V_{DD}=AV_{DD}=2.5V$ to 5.5V, $R_L=8\Omega$	12	16	20	$\frac{V}{V}$
$R_{SDN}$ Resistance from shutdown to GND	$V(\text{SDNB})=5V$		200		k $\Omega$

Zi	Input impedance	RINN,RINP,LINN,LINP	15	kΩ
----	-----------------	---------------------	----	----

\*The gain of the amplifier is determined by, for  $V_{DD}=V_{DDA}=2.5V$  to  $5.5V$

$$\text{Gain} = \frac{320\text{kohms}}{R_i + 15\text{kohms}} \quad \text{where } R_i \text{ is the external serial resistance at the input pin.}$$

### OPERATING CHARACTERISTICS

$T_A=25^\circ\text{C}$ ,  $R_L=8\Omega$  speaker (unless otherwise noted)

PARAMETER		TEST CONDITIONS		MIN	TYP	MAX	UNIT
Po	Output power (SE output)	$V_{DD}=AV_{DD}=5V$ , THD+N=10%, f=1kHz	$R_L=4\Omega$		0.6		W
	Output power (bass)		$R_L=8\Omega$		1.5		
			$R_L=4\Omega$		2.3		
			$R_L=3\Omega$		2.7		
THD+N	Total harmonic distortion plus noise (SE output)	$V_{DD}=AV_{DD}=5V$ , f=1kHz	$P_O=0.6W, R_L=4\Omega$ ,		0.8		%
	Total harmonic distortion plus noise (bass)		$P_O=0.85W, R_L=8\Omega$ ,		0.55		
			$P_O=1.3W, R_L=4\Omega$ ,		0.55		
			$P_O=1.5W, R_L=3\Omega$ ,		0.64		
SNR	Signal-to-noise ratio	$V_{DD}=AV_{DD}=5V, P_O=1W, R_L=8\Omega$			95		dB
Crosstalk	Crosstalk between outputs	$V_{DD}=AV_{DD}=5V, P_O=1W, R_L=8\Omega$			-68		dB

### TERMINAL FUNCTIONS

TERMINAL		I/O	DESCRIPTION
NAME	PIN NO		
AGND	15	-	Analog ground
AVDD	16	-	Analog Power supply
CAP	14	I	Capacitance for power up delay
GND	11,20	-	Digital ground
BINN	5	I	Negative input of bass
BINP	4	I	Positive input of bass
BOUTN	19	O	Negative output of bass
BOUTP	1	O	Positive output of bass
NC	3,8	-	No Connection
LIN	6	I	Input of left channel
RIN	7	I	Input of right channel
LOUT	12	O	Output of left channel
ROUT	10	O	Output of right channel
SDNB	17	I	Shutdown terminal (LOW active)
VDD	2,9,13,18	-	Digital Power supply

### **TYPICAL CHARACTERISTICS**

Note 1. Input coupling 1 $\mu$ F capacitors are used for all measurements.

2. Differential inputs are applied for BTL output.
3. Balanced LC filter is used for THD+N measurement and power efficiency measurement.
4. Characteristic frequency of the LC filter is set 41KHz unless otherwise specified.

## APPLICATION INFORMATION

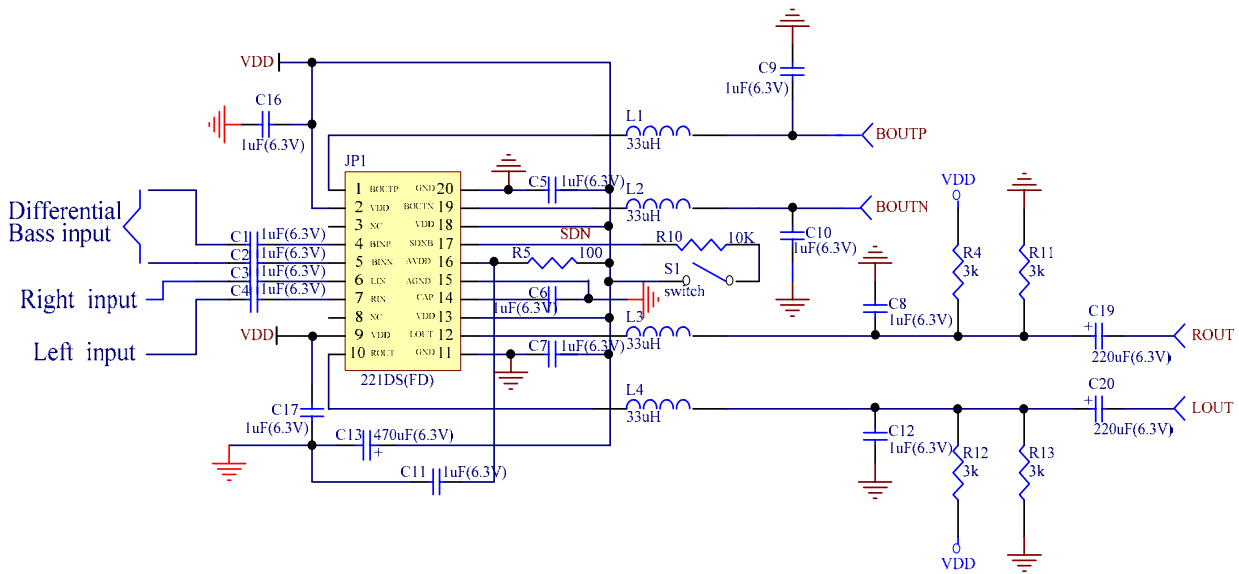

Figure.1 Differential Bass Input

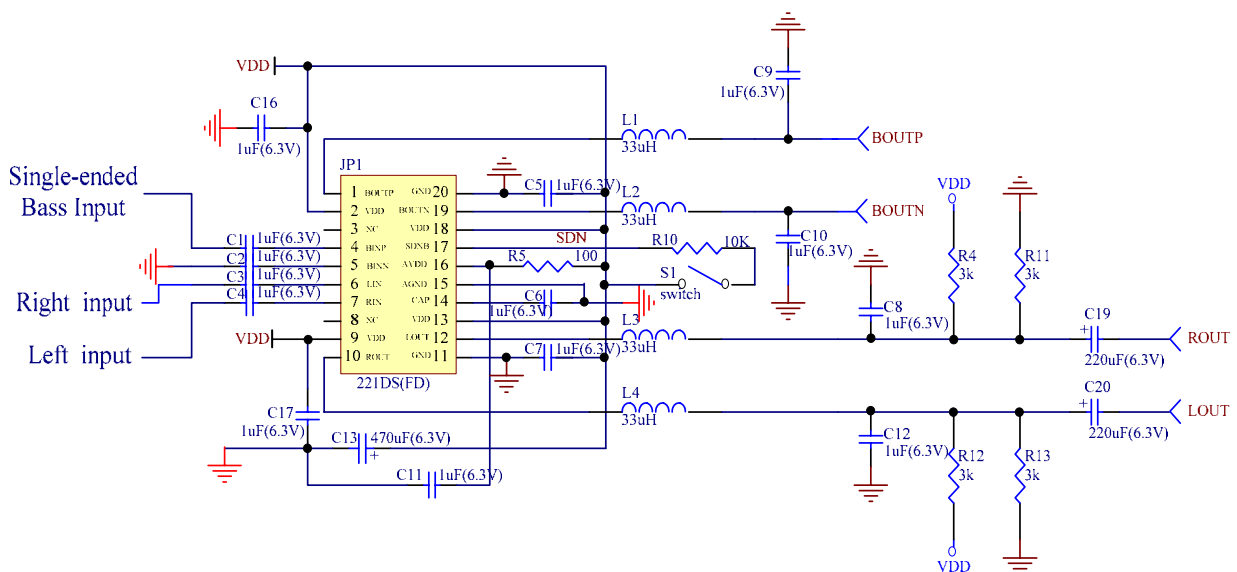

Figure.2 Single-ended Bass Input

## Input Resistors and Gain

The gain of the amplifier is determined by, for VDD=VDDA =2.5V to 5.5V

$$\text{Gain} = \frac{320\text{kohms}}{R_i + 15\text{kohms}} \quad \text{where } R_i \text{ is the external serial resistance at the input pin.}$$

Note : Please refer to document 010 APP for more application examples.

## DETAILED DESCRIPTION

### Efficiency

The output transistors of a class D amplifier act as switches. The power loss is mainly due to the turn on resistance of the output transistors when driving current to the load. As the turn on resistance is so small that the power loss is small and the power efficiency is high. With 8 ohm load the power efficiency can be better than 82%.

### Shutdown

The shutdown mode reduces power consumption. A LOW at shutdown pin forces the device in shutdown mode and a HIGH forces the device in normal operating mode. Shutdown mode is useful for power saving when not in use. This function is useful when other devices like earphone amplifier on the same PCB are used but class D amplifier is not necessary.

Internal circuit for shutdown is shown below.

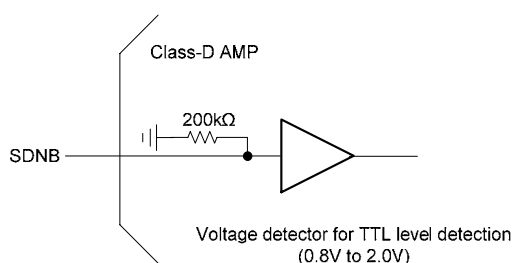

### Pop-less

A soft start capacitor can be added to the CAP pin. This capacitor introduces delay for the internal circuit to be stable before driving the load. The pop or click noise when power up/down or switching in between shutdown mode can be thus eliminated. The delay time is proportional to the value of the capacitance. It is about 500ms for a capacitor of 1uF at 5v.

### CAP

Cap provides a way of soft startup delay. A 5uA current source and a half\_Vcc detector are integrated in the chip. The charged capacitor is externally hooked up. For C=1uF the half\_Vcc delay is

$$T = CV / I = ( 1\mu\text{F} \times 2.5\text{V} ) / 5\mu\text{A} = 0.5 \text{ seconds}$$



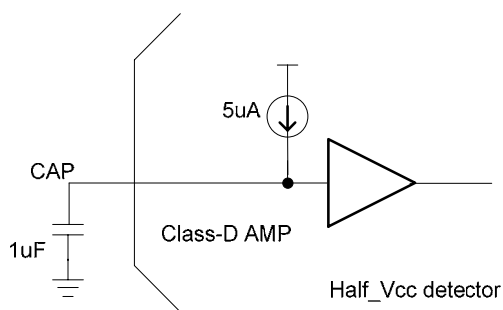

### Differential input VS single ended input

Differential input offers better noise immunity over single ended input. A differential input amplifier suppresses common noise and amplifies the difference voltage at the inputs. For single ended applications just tie the negative input end of the balanced input structure to ground. If external input resistors are used, the negative input has to be grounded with a series resistor of the same value as the positive input to reduce common noise.

### Automatic output Power Control (APC)

The voltage gain is self adjusted in the chip over voltage range. This means that, regardless supply voltage change, the output power keeps about the same for a given input level from  $V_{DD}=5.5v$  to  $2.5v$ . It allows the best use of the battery.

### Voltage gain

The voltage gain is defined in the table on page 3. For lower voltage gain one can add external input resistors to input pins. If external resistors are used they should be well matched. Well matched input resistors are also required even for single-ended input configuration for low noise. If band pass filters are used for frequency separation please refer to following discussion.

### Band pass filter for frequency separation of bass and R/L channels

For best sound effect the frequency of bass and R/L channels has to be separated. The bass channel amplifies the lower frequencies while the R/L channels amplify the higher frequencies. The power is saved not to drive bass speaker with high frequencies and not to drive R/L channel speakers with low frequencies. The noise level can be reduced as well. Typically the frequency boundary of bass and R/L channels is set 500 Hz and the output power of bass is set around 3~5 times of the R/L channels. Note that different applications may have different requirement for these values. Please refer to EVM documentation if the separation frequency is

200 Hz instead.

## Bass channel filter

If the audio source is stereo (right channel signal and left channel signal) one can generate audio source for bass amplifier by mixing right and left signals and in the mean time filter out frequencies above 500 Hz. A typical application is shown below. Note that  $Z_{in}=15k$  ohms is the internal resistance of the class-D amplifier when  $gain_0=gain_1=High$ .

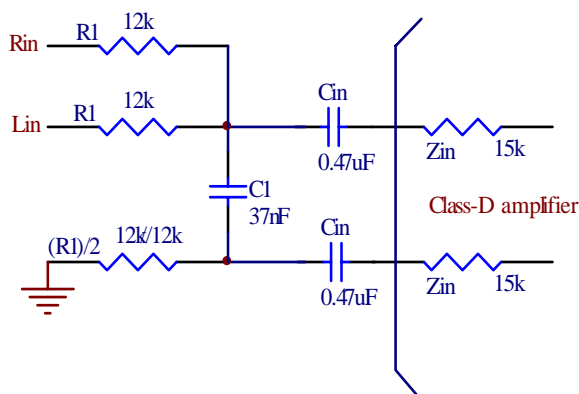

The -3dB frequency at high frequency corner is  $f_{-3dB} = 1 / (2 R C)$  where  $R=2(Z_{in} // (R1)/2)$  and  $C=C1$ . With specified values  $f_{-3dB} = 500Hz$ .

The -3dB frequency at low frequency corner is calculated as  $f_{-3dB} = 1 / (2 R C)$  where  $R=Z_{in} + (R1)/2$  and  $C=Cin$ . With specified values  $f_{-3dB} = 16Hz$ .

## Right and Left channel filters

To block frequencies below 500Hz, a typical application is shown below.

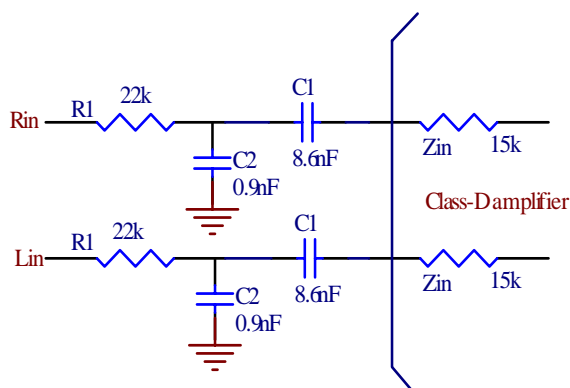

The -3dB frequency at low frequency corner is  $f_{-3dB} = 1 / (2 R C)$  where  $R=Z_{in} + R1$  and  $C=C1$ . With specified values  $f_{-3dB} = 500Hz$ .

The -3dB frequency at high frequency corner is  $f_{-3dB} = 1 / (2 R C)$  where  $R = Z_{in} // R1$  and  $C = C2$ . With specified values  $f_{-3dB} = 20kHz$ .

Note that if gain0 and gain1 are set at different states the internal input resistance is changed accordingly. Please refer to DC CHARACTERISTICS for detail. As such the filters should be redesigned to meet the 500 Hz frequency boundary.

### Power ratio of bass channel and right/left channels

The output power ratio of bass to R/L channels is normally set 3~5. However different music has different stress in different frequency range. It becomes difficult to define a fix voltage gain for different applications and to maintain the requirement of bass to R/L ratio. A convenient way of controlling the ratio is to make bass adjustable relative to R/L channels. An easier way is to use VR as shown below.

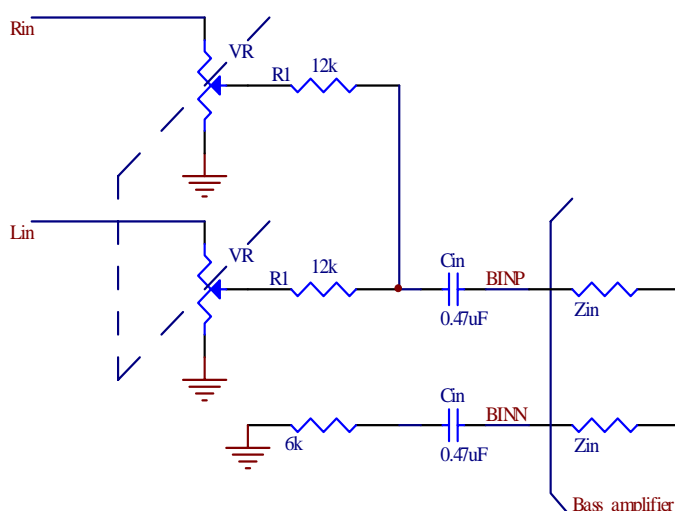

Another way is to use frequency synthesizer to preset voltage gain for different frequency range for particular music content.

For simply applications an example is given below to show 3X ratio between bass output power and R/L output power.

For  $V_{cc}=15v$  and 8ohm load the voltage gain of the bass channel is around 32. If the power ratio is 3 then the voltage ratio is  $\sqrt{3} = 1.732$  and the gain of the R/L channel is 18.5. The voltage gain of the R/L channels is roughly defined as

$$(750k \text{ ohms}) / (R_i + 15k \text{ ohms})$$

resulting  $R_i = 25.5k$  ohms.

To meet the -3dB frequency of the R/L channels which is 500Hz, the filter capacitance should be adjusted to

$$C = 1/(2 \times (25.5k + 15k \text{ ohms}) \times 500\text{Hz}) = 7.86\text{nF}.$$

For higher output power one can consider to use 4 ohm speaker for bass and 8 ohm speakers for R/L channels. Suppose the power ratio is set 5X, then the voltage ratio is  $\sqrt{5/2} = 1.58$ . For  $V_{cc} = 15v$  and 4ohm load the voltage gain of the bass channel is around 30. Thus the gain of the R/L channel is 19.

The voltage gain of the R/L channels is defined as

$$(750k \text{ ohms}) / (R_i + 15k \text{ ohms})$$

resulting  $R_i = 24.5k$ ohms .

To meet the -3dB frequency of the R/L channels which is 500Hz, the filter capacitance should be adjusted to

$$C = 1/(2 \times (24.5 + 15k \text{ ohms}) \times 500) = 8\text{nF}.$$

Note that the formula for voltage gain varies with supply voltage and loading. But the procedure is to find out the value of  $R_i$  before the capacitance is determined.

### Output coupling capacitor

The speaker of the bass channel is tied as BTL. There is no need to have an output capacitor at the output end. But for right and left channels coupling capacitors are required to block DC from the speakers. Since the right and left channels do not amplify frequencies below 500Hz the output coupling capacitance does not have to be big. One can choose the -3dB frequency of the output coupling stage to be 200Hz, not too high to attenuate voltage at 500Hz, then the coupling capacitance is

$$C = 1/(2 \times 8 \text{ ohm} \times 200\text{Hz}) = 100\mu\text{F} \text{ for } 8 \text{ ohm load}.$$

or  $C = 1/(2 \times 4 \text{ ohm} \times 200\text{Hz}) = 200\mu\text{F} \text{ for } 4 \text{ ohm load}.$

## Input filter

In case band pass filter for frequency separation of bass and R/L channels is not used, the AC coupling capacitors are still required to block the DC voltage from the device. They also define the  $-3\text{dB}$  frequency at the low frequency side.

The  $-3\text{dB}$  frequency of the low frequency side is

$$f_{-3\text{dB}} = 1 / (2 \pi R C)$$

where C is the AC coupling capacitance and R is the total resistance in series with C.

Note that  $R = Z_{\text{in}}$ (internal resistance) +  $R_{\text{ext}}$ (external resistance)

Also note that the input resistance of BINN/BINP/LIN/RIN is 15K ohms at Gain0=Gain1=high.

Please refer to DC CHARACTERISTICS for detail.

## Output filter

Ferrite bead filter can be used for EMI purpose. The ferrite filter reduces EMI around 1 MHz and higher ( FCC and CE only test radiated emissions greater than 30 MHz ) . When selecting a ferrite bead, choose one with high impedance at high frequencies, but low impedance at low frequencies.

Use an LC output filter if there are low frequency ( < 1 MHz ) EMI sensitive circuits and/or there are long wires from the amplifier to the speaker. EMI is also affected by PCB layout and the placement of the surrounding components.

The suggested LC values for different speaker impedance are showed in following figures for reference.

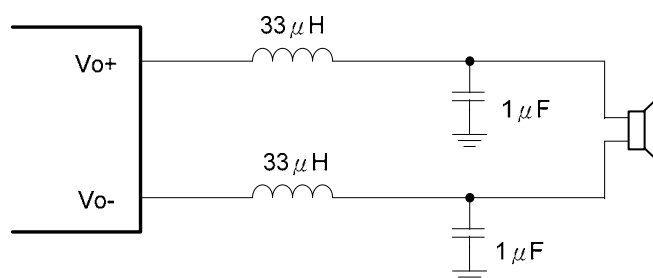

Typical LC Output Filter (1)

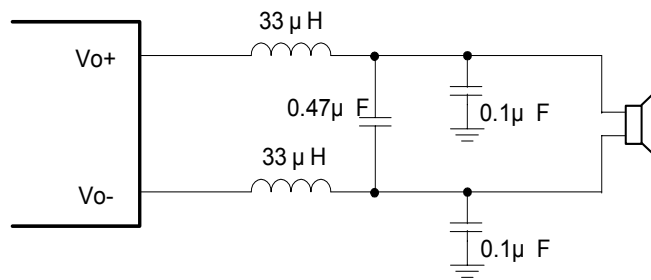

Typical LC Output Filter (2)

### EARPHONE APPLICATION

Class-D output can be used to drive earphone. However to avoid high power to overdrive earphone and to prevent human ear to accidentally be hurt by loud noise, a resistor has to be put in series with the earphone speaker. Typically a resistor of 330 ohms is adequate for this purpose.

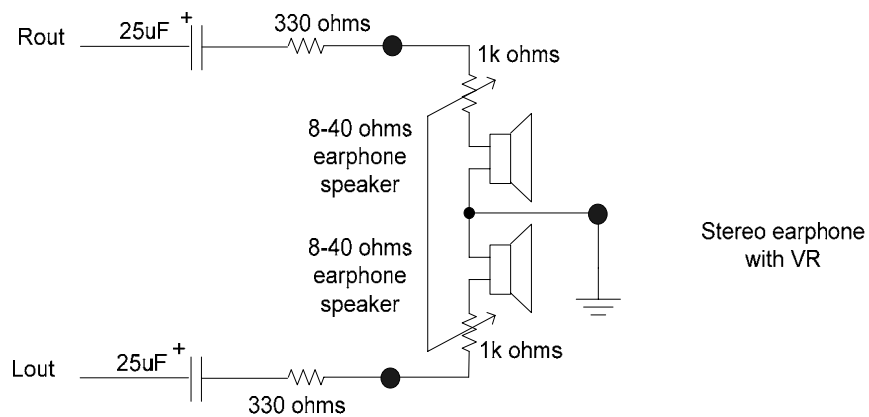

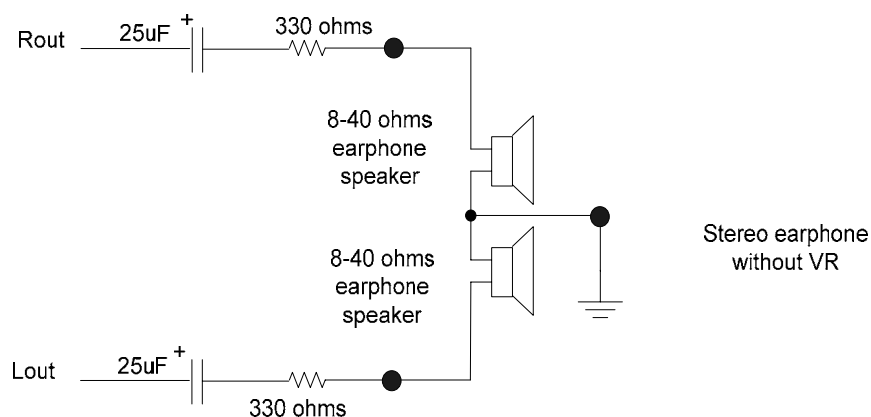

## Over temperature protection

A temperature sensor is built in the device to detect the temperature inside the device. When a high temperature around  $145\ ^\circ C$  and above is detected the switching output signals are disabled to protect the device from over temperature. Automatic recovery circuit enables the device to come back to normal operation when the internal temperature of the device is below around  $120\ ^\circ C$ .

## Over current protection

A current detection circuit is built in the device to detect the switching current of the output stages of the device. It disables the device when the current is beyond about 3.5amps. It protects the device when there is an accident short between outputs or between output and power/gnd pins. It also protects the device when an abnormal low impedance is tied to the output. High current beyond the specification may potentially causes electron migration and permanently damage the device. Shutdown or power down is necessary to resolve the protection situation. There is no automatic recovery from over current protection.

**Physical Dimensions (IN MILLIMETERS)**

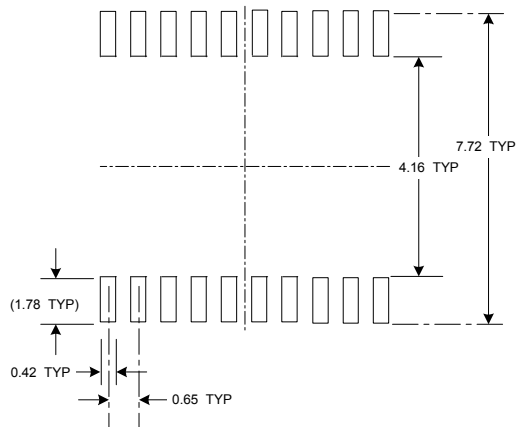
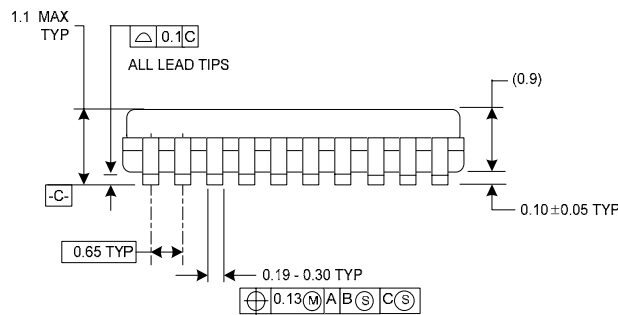
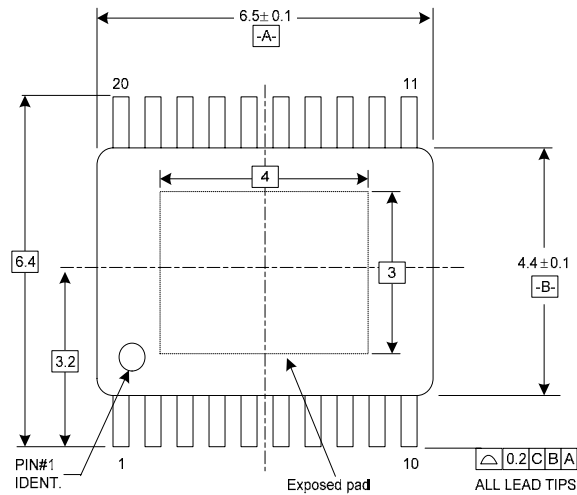

LAND PATTERN

**TSSOP20**



## IMPORTANT NOTICE

Tai-1 Microelectronics Corp. reserves the right to make changes to its products and services and to discontinue any product or service without notice. Customers should obtain the latest relevant information for reference. Testing and quality control techniques are used to screen the parameters. Testing of all parameters of each product is not necessarily performed.

Tai-1 Microelectronics Corp. assumes no liability for applications assistance or customer product design. To minimize the risks associated with customer products and applications, customers should provide adequate design and operating safeguards.

Reproduction of information in data sheets or related documentation is permissible only if reproduction is without alteration and is accompanied by all associated warranties, conditions, limitations, and notices. Tai-1 Microelectronics Corp. is not responsible or liable for such altered documentation.

Resale of Tai-1 Microelectronics Corp. products or services with statements different from the parameters stated by Tai-1 Microelectronics Corp. for that product or service voids all express and any implied warranties. Tai-1 Microelectronics Corp. is not responsible or liable for any such statements.

Copyright ©2005, Tai-1 Microelectronics Corp.