

DIMENSIONS						
REF.	mm			inch		
	MIN.	TYP.	MAX.	MIN.	TYP.	MAX.
A			1.2			0.047
A1	0.05		0.15	0.002	0.004	0.006
A2	0.8	1	1.05	0.031	0.039	0.041
b	0.19		0.30	0.007		0.012
c	0.09		0.20	0.004		0.0089
D	4.9	5	5.1	0.193	0.197	0.201
E	6.2	6.4	6.6	0.244	0.252	0.260
E1	4.3	4.4	4.48	0.169	0.173	0.176
e		0.65			0.0256	
K	0°		8°	0°		8°
L	0.45	0.60	0.75	0.018	0.024	0.030

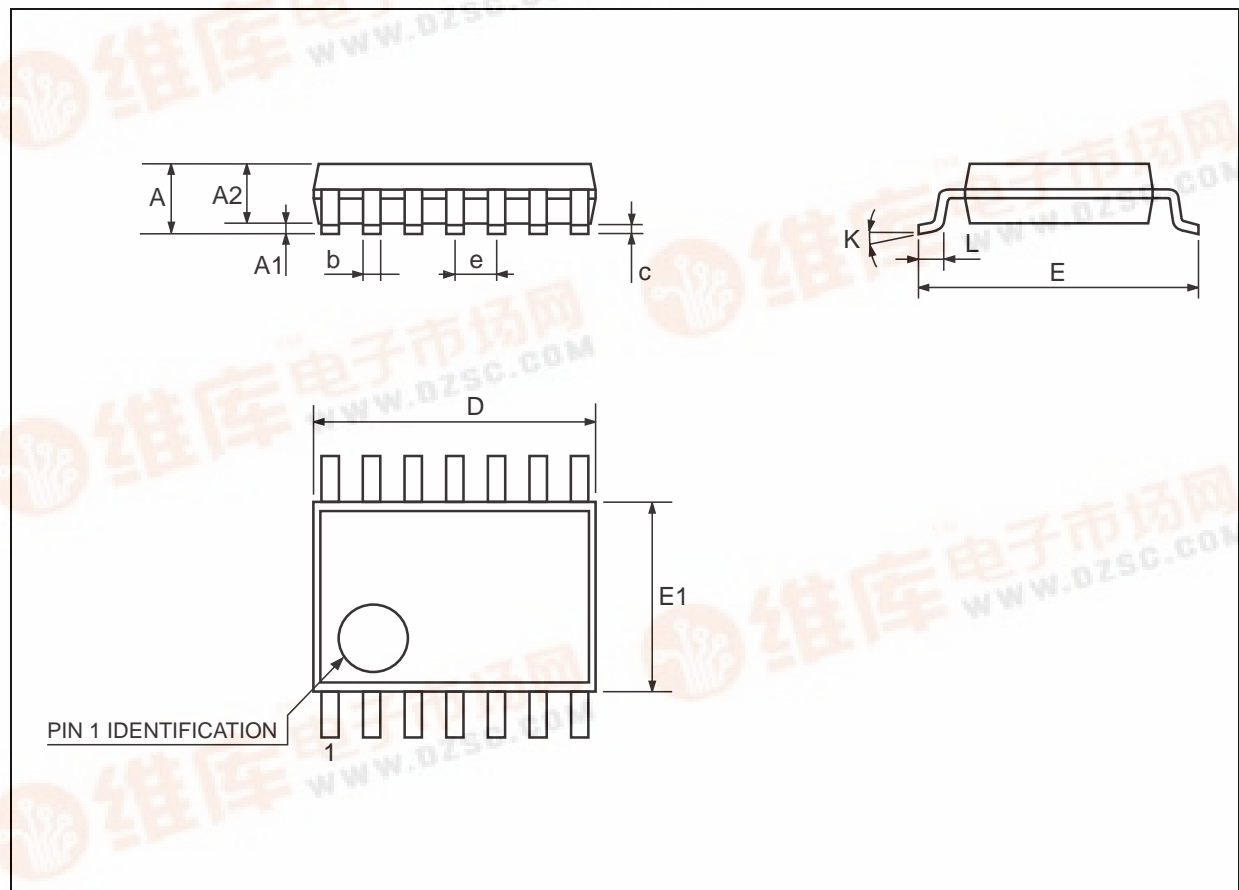

14-LEAD THIN SHRINK SMALL OUTLINE



TSSOP14 PACKAGE AND PACKING INFORMATION

TAPE & REEL SHIPMENT INFORMATION

TAPE SPECIFICATIONS

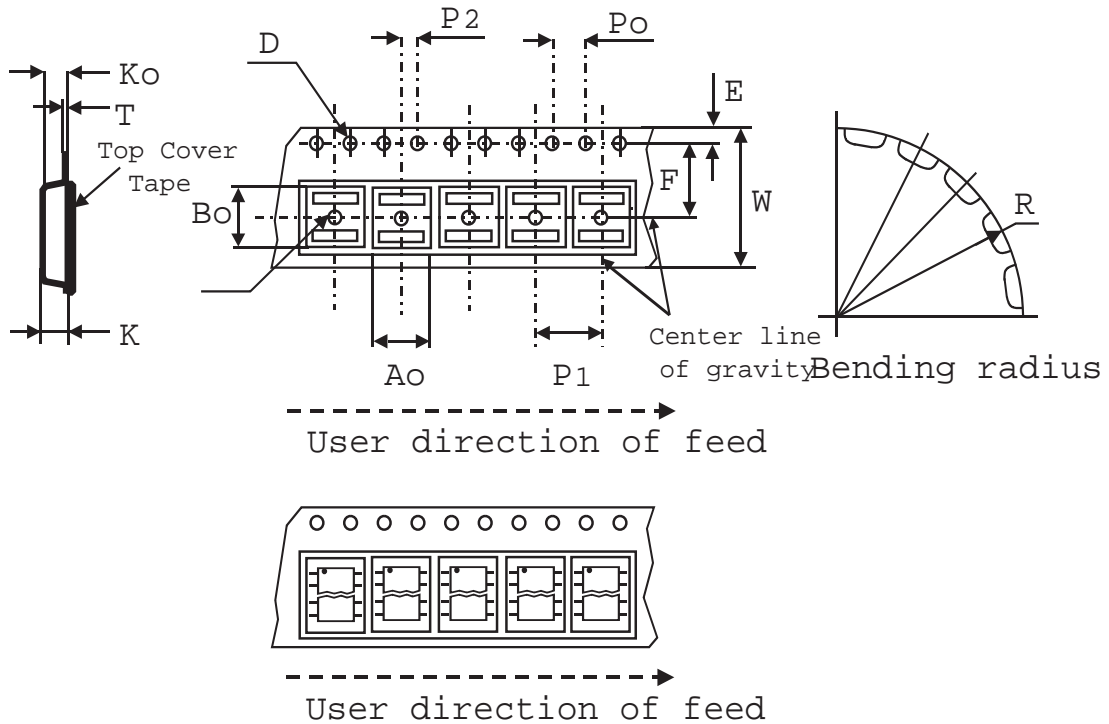

TAPE MECHANICAL DATA		
	mm.	inch
D	1.50 +0.1/0	0.059 +0.004/0
E	1.75 ±0.1	0.069 ±0.004
P0	4.00 ±0.1	0.157 ±0.004
T max.	0.40	0.016
D1 min.	1.50	0.059
F	7.5 ±0.05	0.295 ±0.002
K max.	6.50	0.256
P2	2.00 ±0.05	0.079 ±0.002
R	40	1.575
W	16.00 ±0.30	0.630 ±0.012
P1	8.00	0.315
Ao, Bo, Ko	0.05 min to 0.90 max.	0.002 min to 0.035 max.

BASE QUANTITY	2500 pcs.
BULK QUANTITY	2500 pcs.

TSSOP14 PACKAGE AND PACKING INFORMATION

TAPE & REEL SHIPMENT INFORMATION
REEL SPECIFICATIONS

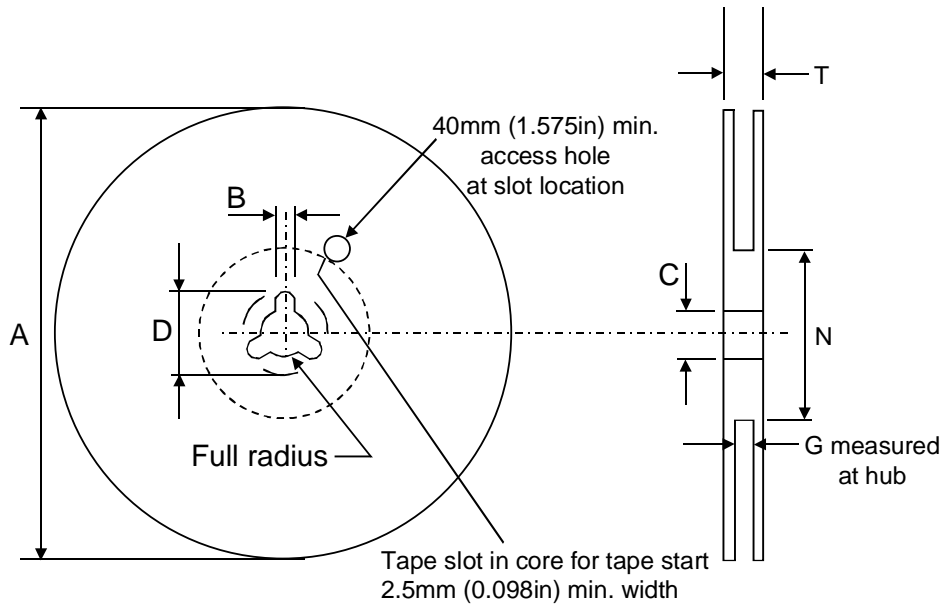

REEL MECHANICAL DATA		
	mm.	inch
Tape size	16.0 ±0.30	0.630 ±0.012
A max.	330.0	12.992
B min.	1.5	0.059
C	13.0 ±0.20	0.512 ±0.008
D min.	20.2	0.795
N min.	60	2.362
G	16.4 +2/-0	0.646 +0.079/-0
T max.	22.4	0.882

TSSOP14 PACKAGE AND PACKING INFORMATION

FOOTPRINT RECOMMENDED DATA

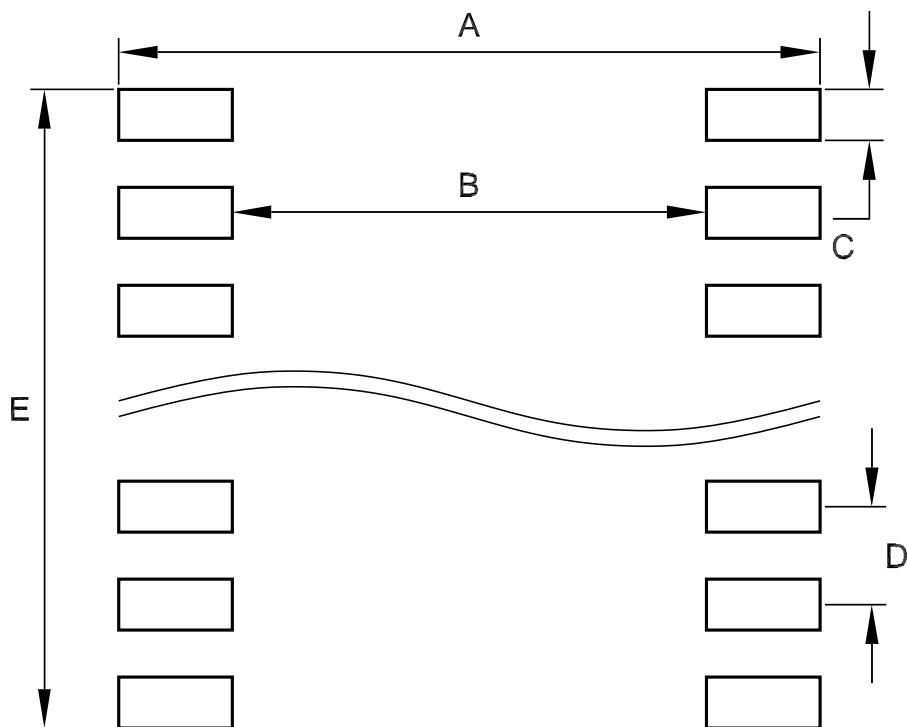

FOOTPRINT DATA		
	mm.	inch
A	7.26	0.286
B	4.93	0.194
C	0.36	0.014
D	0.65	0.025
E	4.26	0.168