



Document History Information

Revision	Date	Description
Ver. 1.0	May 16, 2005	Release with W3150 Launching



WIZnet's Online Technical Support

If you have something to ask about WIZnet Products, Write down your question on Q&A Board in WIZnet website (www.wiznet.co.kr). WIZnet Engineer will give an answer as soon as possible.

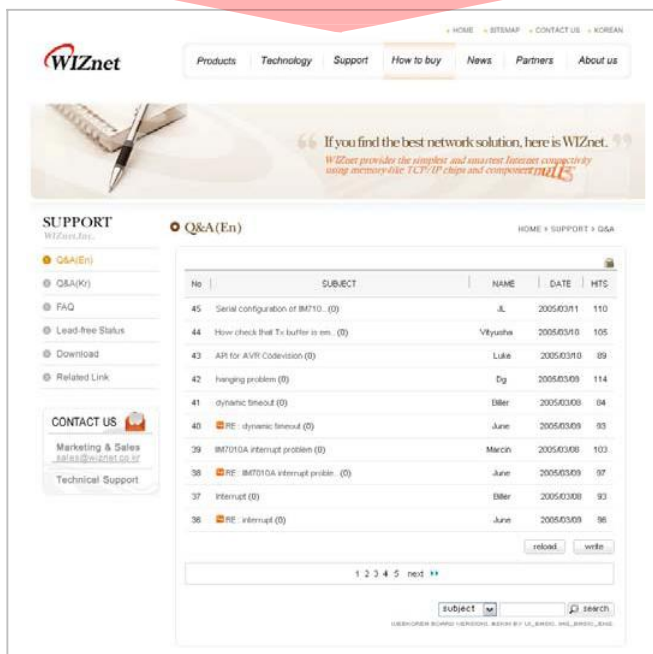
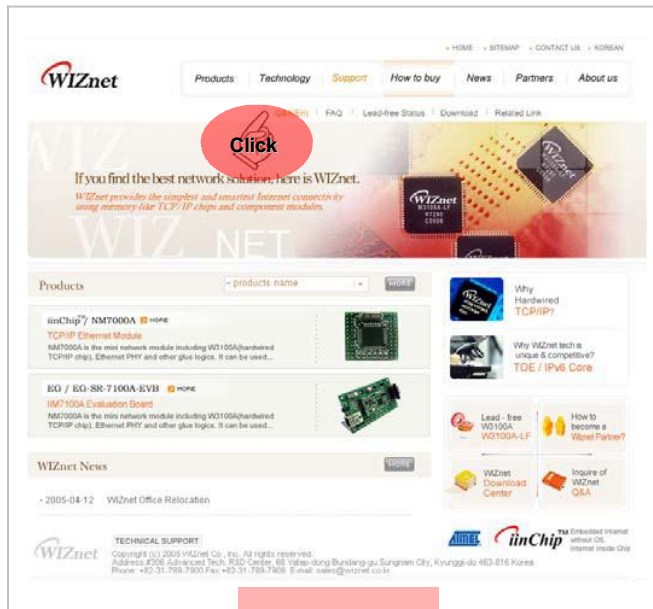

iinChip™ W3150 Datasheet

Description

The iinChip™ W3150 is an LSI of hardware protocol stack that provides an easy, low-cost solution for high-speed Internet connectivity for digital devices by allowing simple installation of TCP/IP stack in the hardware.

The W3150 offers system designers a quick, easy way to add Ethernet networking functionality to any product. Implementing this LSI into a system can completely offload Internet connectivity and processing standard protocols from the system, thereby significantly reducing the software development cost.

The W3150 contains TCP/IP Protocol Stacks such as TCP, UDP, ICMP, IPv4, ARP and PPPoE protocols, as well as Ethernet protocols such as Data Link Control and MAC protocol. The total internal memory size is 16Kbytes, which is the buffer for transmit and receive operations.

The W3150 provides a local bus interface to various MCUs and standard MII(Media Independent Interface) specification consisting of nibble data bus for Ethernet PHY devices.

The W3150 is a best-fitted device for embedded application with Internet-Connectivity including IP-Setop Box, Internet-DVR, Internet phones, VoIP SOC chips, Internet MP3 players, handheld medical devices, various industrial system monitoring and metering, and many other non-portable electronic devices such as large consumer electronic products.

Features

- Support Hardwired TCP/IP Protocols : TCP, UDP, ICMP, IPv4, ARP, PPPoE, Ethernet
- Support PPPoE Protocol with PAP/CHAP Authentication mode
- Supports 4 independent sockets simultaneously
- Standard MII Interface for Ethernet-PHY chip
- Supports 10BaseT/100BaseTX
- Supports full-duplex mode
- Internal 16Kbytes Memory for Tx/Rx Buffers
- 0.25 μm CMOS technology
- 3.3V operation with 5V I/O signal tolerance
- Small 64 Pin LQFP Package
- Lead-Free Package
- Commercial Temperature Range from 0°C to 80°C

Block Diagram

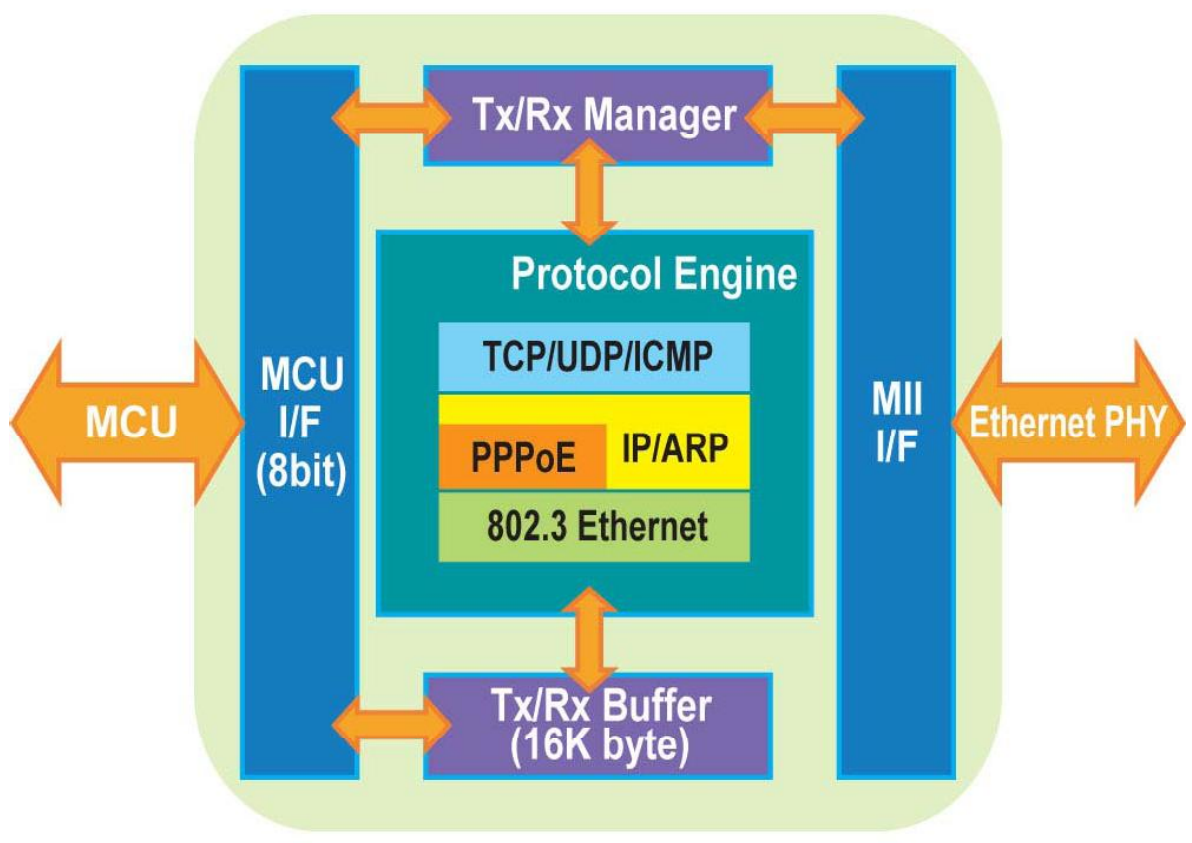

Table of Contents

Description	3
Features	3
Block Diagram	4
Table of Contents	5
1. Pin Assignment	7
1.1. MII Signal Description	8
1.2. MCU Interface Signal Description	9
1.3. Miscellaneous Signal Description	10
1.4. Power Supply Signal Description	11
2. Memory map	12
3. W3150 Registers	13
3.1. Common Registers	13
3.2. Socket Registers	14
4. Register Descriptions	18
4.1. Common Registers	18
4.2. Socket Registers	24
5. Functional Description	32
5.1. Initialization	32
5.2. Data communication	32
5.2.1. TCP	32
5.2.2. UDP	39
5.2.3. IP raw	42
5.3. Usage of PPPoE environment	44
6. Application Information	48
6.1. Direct Bus I/F Mode	48
6.2. Indirect Bus I/F Mode	48
6.3. MII (Media Independent Interface)	49
7. Electrical Specification	50
7.1. Absolute Maximum Ratings	50
7.2. DC Characteristics	50
7.3. AC Characteristics	51
7.3.1. Reset Timing	51
7.3.2. Register/Memory READ Timing	52
7.3.3. Register/Memory WRITE Timing	53
7.3.4. MII(Media Independent Interface) Timing	54



8. IR Reflow Temperature Profile (Lead-Free).....	56
9. Package Description	57



1. Pin Assignment

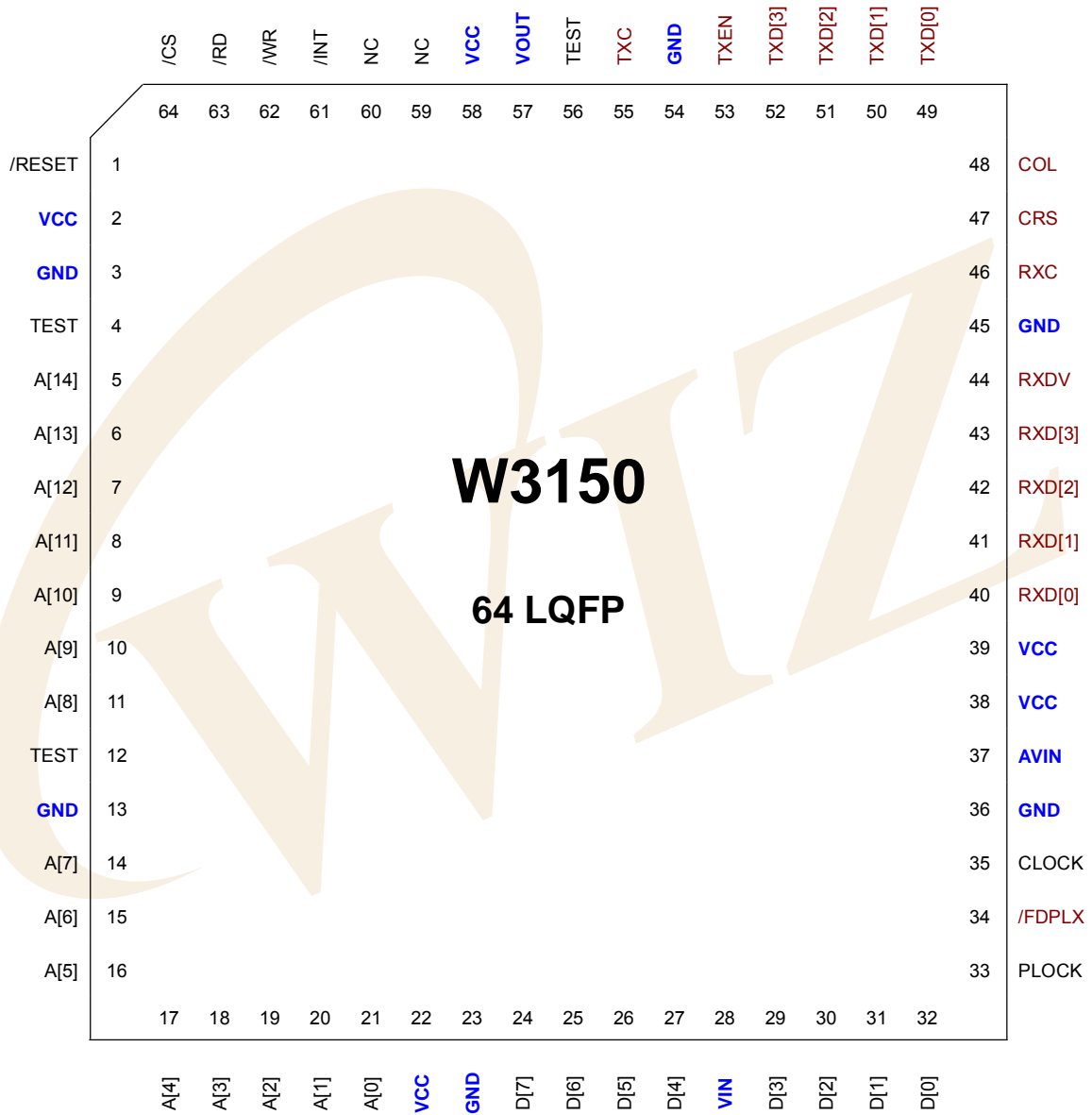

1.1. MII Signal Description

Pin#	Signal	I/O	Description
55	TXC	I	Transmit Clock This pin provides a continuous clock as a timing reference for TXD[3:0] and TXEN. TXC is sourced by the PHY. TXC is 2.5 MHz in 10BASET Nibble mode, and 25 MHz in 100BASETX Nibble mode.
53	TXEN	O	Transmit Enable This output signal indicates the presence of a valid nibble data on TXD[3:0]. It becomes active when the first nibble data of the packet is valid on TXD[3:0] and goes low after the last nibble data of the packet is clocked out of TXD[3:0]. This signal connects directly to the PHY device. This signal is active high.
52 51 50 49	TXD[3] TXD[2] TXD[1] TXD[0]	O	Transmit Data These pins provide Nibble NRZ data to the PHY synchronously with TXC when TXEN is asserted.
46	RXC	I	Receive Clock This pin provides a continuous clock reference for RXDV and RXD[3:0] signals. RXC is sourced by the PHY. RXC is 2.5 MHz in 10BASET Nibble mode, and 25 MHz in 100BASETX Nibble mode.
48	COL	I	Collision Detect This pin becomes active when a collision has been detected in Half Duplex modes. This signal is asynchronous, active high and ignored during full-duplex operation. This signal is active high.
47	CRS	I	Carrier Sense This pin indicates that carrier is present. This signal is active high.
44	RXDV	I	Receive Data Valid This signal is asserted high when received data is present on the RXD[3:0] pins; the signal is deasserted at the end of the packet. The signal is valid on the rising of the RXC.
43 42 41 40	RXD[3] RXD[2] RXD[1] RXD[0]	I	Receive Data These pins receive Nibble NRZ data from the PHY device synchronously with RXC when RXDV is asserted.

1.2. MCU Interface Signal Description

Pin#	Signal	I/O	Description
1	/RESET	I	RESET Active Low input that initializes or re-initializes W3150. Asserting this pin low for at least 125us will force a reset process to occur which will result in all internal registers re-initializing to their default states.
35	CLOCK	I	CLOCK This pin is the Primary clock required for internal operation of W3150. In general, PHY driving clock can be shared for saving cost. 25MHz is required. <i>Note) Sharing crystal source clock with multiple devices may cause some troubles. In our reference design, we used one crystal for both PHY and W3150 with verification.</i> <i>But for other kind of PHY, please confirm safety prior to decision.</i>
5:11 14:21	A[14:8] A[7:0]	I	ADDRESS PINS These pins are used to select a register or memory.
24:27, 29:32	D[7:4] D[3:0]	I/O	DATA PINS These pins are used to read and write register or memory data.
61	/INT	O	INTERRUPT This pin Indicates that W3150 requires MCU attention after socket connecting, disconnecting, receiving data or timeout. The interrupt is cleared by reading IR(Interrupt Register) or Sn_IR (Socket nth Interrupt Register). All interrupts are maskable. This signal is active low.
64	/CS	I	CHIP SELECT Chip Select places for MCU access to internal registers/memory. /WR and /RD select direction of data transfer. This signal is active low.
62	/WR	I	WRITE ENABLE Strobe from MCU to write an internal register/memory selected by A[14:0]. Data is latched into the W3150 on the rising edge of this input. This signal is active low.
63	/RD	I	READ ENABLE Strobe from MCU to read an internal register/memory selected by A[14:0]. This signal is active low.

1.3. Miscellaneous Signal Description

Pin#	Signal	I/O	Description
34	/FDPLX	I	<p>FULL/HALF DUPLEX SELECT</p> <p>This pin selects Half/Full Duplex operation.</p> <p>This pin must be externally pulled low (typically x kΩ) in order to configure the W3150 for Full Duplex operation.</p> <p>Low = Full Duplex High = Half Duplex</p>
33	PLOCK	O	<p>PLL Lock</p> <p>Internal PLL Lock detector out. When the lock signal is High, W3150 is ready to start. The lock signal always low when the PLL is in setting time. This signal is active high.</p>
4,12,56	TEST	I	<p>FACTORY TEST INPUT</p> <p>Used to check the chip's internal functions. This should be tied low during normal operation.</p>
59, 60	NC		

1.4. Power Supply Signal Description

Pin#	Signal	I/O	Description
2, 22, 38, 39, 58	VCC		POSITIVE 3.3V SUPPLY PINS
28	VIN		2.5V power input 2.5V power supply
37	AVIN		2.5V Analog power input 2.5V power supply for analog circuit ; should be well decoupled. Refer Figure 1-1. Reference Schematic for Power input.
57	VOUT		2.5V power out Be sure to connect 10uF tantalum capacitor and a 0.1uF capacitor for noise de-coupling. Then connect this pin through a ferrite bead to VIN and AVIN.
3, 13, 23, 36, 45, 54	GND		NEGATIVE (GROUND) SUPPLY PINS

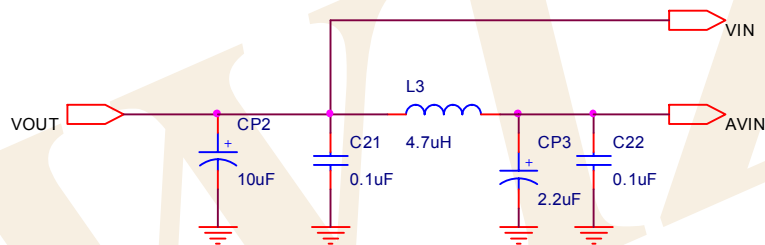
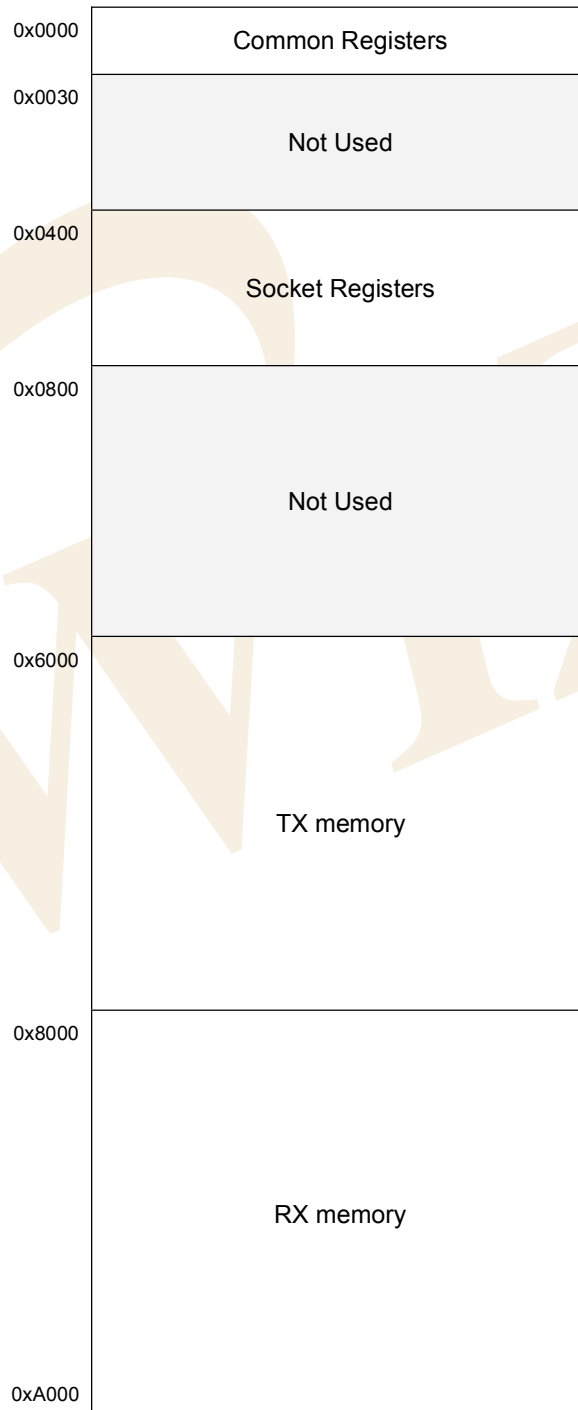

Figure 1-1. Reference Schematic for Power input

2. Memory map

W3150 is composed of Common Register, Socket Register, TX Memory, and RX Memory. Each field is shown as below.



3. W3150 Registers

3.1. Common Registers

Address	Register
0x0000	Mode (MR)
0x0001	Gateway Address (GAR0)
0x0002	(GAR1)
0x0003	(GAR2)
0x0004	(GAR3)
0x0005	Subnet mask Address (SUBR0)
0x0006	(SUBR1)
0x0007	(SUBR2)
0x0008	(SUBR3)
0x0009	Source Hardware Address (SHAR0)
0x000A	(SHAR1)
0x000B	(SHAR2)
0x000C	(SHAR3)
0x000D	(SHAR4)
0x000E	(SHAR5)
0x000F	Source IP Address (SIPR0)
0x0010	(SIPR1)
0x0011	(SIPR2)
0x0012	(SIPR3)
0x0013	Type Of Service of IP (TOSR)
0x0014	Time To Live of IP (TTLR)
0x0015	Interrupt (IR)
0x0016	Interrupt Mask (IMR)
0x0017	Retry Time (RTR0)
0x0018	(RTR1)
0x0019	Retry Count (RCR)

Address	Register
0x001A	RX Memory Size (RMSR)
0x001B	TX Memory Size (TMSR)
0x001C	Authentication Type in PPPoE (PATR0)
0x001D	(PATR1)
0x001E	Reserved
~ 0x0029	
0x002A	Unreachable IP Address (UIPR0)
0x002B	(UIPR1)
0x002C	(UIPR2)
0x002D	(UIPR3)
0x002E	Unreachable Port (UPORT0)
0x002F	(UPORT1)
0x0030	Reserved
~ 0x03FF	

3.2. Socket Registers

Address	Register
0x0400	Socket 0 Mode (S0_MR)
0x0401	Socket 0 Command (S0_CR)
0x0402	Socket 0 Interrupt (S0_IR)
0x0403	Socket 0 Socket Status (S0_SSR)
0x0404	Socket 0 Source Port (S0_PORT0)
0x0405	(S0_PORT1)
0x0406	Socket 0 Destination Hardware Address (S0_DHAR0)
0x0407	(S0_DHAR1)
0x0408	(S0_DHAR2)
0x0409	(S0_DHAR3)
0x040A	(S0_DHAR4)
0x040B	(S0_DHAR5)
0x040C	Socket 0 Destination IP Address (S0_DIPR0)
0x040D	(S0_DIPR1)
0x040E	(S0_DIPR2)
0x040F	(S0_DIPR3)
0x0410	Socket 0 Destination Port (S0_DPORT0)
0x0411	(S0_DPORT1)
0x0412	Socket 0 Maximum Segment Size (S0_MSSR0)
0x0413	(S0_MSSR1)
0x0414	Socket 0 Protocol in IP Raw mode (S0_PROTO)

Address	Register
0x0415	Reserved
~	
0x041F	Socket 0 TX Free Size
0x0420	(S0_TX_FSR0)
0x0421	(S0_TX_FSR1)
0x0422	Socket 0 TX Read Pointer (S0_TX_RR0)
0x0423	(S0_TX_RR1)
0x0424	Socket 0 TX Write Pointer (S0_TX_WR0)
0x0425	(S0_TX_WR1)
0x0426	Socket 0 RX Received Size (S0_RX_RSR0)
0x0427	(S0_RX_RSR0)
0x0428	Socket 0 RX Read Pointer (S0_RX_RR0)
0x0429	(S0_RX_RR1)
0x042A	Socket 0 RX Write Pointer (S0_RX_WR0)
0x042B	(S0_RX_WR1)
0x042C	Reserved
~	
0x04FF	

Address	Register
0x0500	Socket 1 Mode (S1_MR)
0x0501	Socket 1 Command (S1_CR)
0x0502	Socket 1 Interrupt (S1_IR)
0x0503	Socket 1 Socket Status (S1_SSR)
0x0504	Socket 1 Source Port (S1_PORT0)
0x0505	(S1_PORT1)
0x0506	Socket 1 Destination Hardware Address (S1_DHAR0)
0x0507	(S1_DHAR1)
0x0508	(S1_DHAR2)
0x0509	(S1_DHAR3)
0x050A	(S1_DHAR4)
0x050B	(S1_DHAR5)
0x050C	Socket 1 Destination IP Address (S1_DIPR0)
0x050D	(S1_DIPR1)
0x050E	(S1_DIPR2)
0x050F	(S1_DIPR3)
0x0510	Socket 1 Destination Port (S1_DPORT0)
0x0511	(S1_DPORT1)
0x0512	Socket 1 Maximum Segment Size (S1_MSSR0)
0x0513	(S1_MSSR1)
0x0514	Socket 1 Protocol in IP Raw mode (S1_PROTO)

Address	Register
0x0515	Reserved
~ 0x051F	
0x0520	Socket 1 TX Free Size (S1_TX_FSR0)
0x0521	(S1_TX_FSR1)
0x0522	Socket 1 TX Read Pointer (S1_TX_RR0)
0x0523	(S1_TX_RR1)
0x0524	Socket 1 TX Write Pointer (S1_TX_WR0)
0x0525	(S1_TX_WR1)
0x0526	Socket 1 RX Received Size (S1_RX_RSR0)
0x0527	(S1_RX_RSR0)
0x0528	Socket 1 RX Read Pointer (S1_RX_RR0)
0x0529	(S1_RX_RR1)
0x052A	Socket 1 RX Write Pointer (S1_RX_WR0)
0x052B	(S1_RX_WR1)
0x052C	Reserved
~ 0x05FF	

Address	Register
0x0600	Socket 2 Mode (S2_MR)
0x0601	Socket 2 Command (S2_CR)
0x0602	Socket 2 Interrupt (S2_IR)
0x0603	Socket 2 Socket Status (S2_SSR)
0x0604	Socket 2 Source Port (S2_PORT0)
0x0605	(S2_PORT1)
0x0606	Socket 2 Destination Hardware Address (S2_DHAR0)
0x0607	(S2_DHAR1)
0x0608	(S2_DHAR2)
0x0609	(S2_DHAR3)
0x060A	(S2_DHAR4)
0x060B	(S2_DHAR5)
0x060C	Socket 2 Destination IP Address (S2_DIPR0)
0x060D	(S2_DIPR1)
0x060E	(S2_DIPR2)
0x060F	(S2_DIPR3)
0x0610	Socket 2 Destination Port (S2_DPORT0)
0x0611	(S2_DPORT1)
0x0612	Socket 2 Maximum Segment Size (S2_MSSR0)
0x0613	(S2_MSSR1)
0x0614	Socket 2 Protocol in IP Raw mode (S2_PROTO)

Address	Register
0x0615	Reserved
~	
0x061F	Socket 2 TX Free Size (S2_TX_FSR0)
0x0620	
0x0621	
0x0622	Socket 2 TX Read Pointer (S2_TX_RR0)
0x0623	(S2_TX_RR1)
0x0624	Socket 2 TX Write Pointer (S2_TX_WR0)
0x0625	(S2_TX_WR1)
0x0626	Socket 2 RX Received Size (S2_RX_RSR0)
0x0627	(S2_RX_RSR0)
0x0628	Socket 2 RX Read Pointer (S2_RX_RR0)
0x0629	(S2_RX_RR1)
0x062A	Socket 2 RX Write Pointer (S2_RX_WR0)
0x062B	(S2_RX_WR1)
0x062C	Reserved
~	
0x06FF	

Address	Register
0x0700	Socket 3 Mode (S3_MR)
0x0701	Socket 3 Command (S3_CR)
0x0702	Socket 3 Interrupt (S3_IR)
0x0703	Socket 3 Socket Status (S3_SSR)
0x0704	Socket 3 Source Port (S3_PORT0)
0x0705	(S3_PORT1)
0x0706	Socket 3 Destination Hardware Address (S3_DHAR0)
0x0707	(S3_DHAR1)
0x0708	(S3_DHAR2)
0x0709	(S3_DHAR3)
0x070A	(S3_DHAR4)
0x070B	(S3_DHAR5)
0x070C	Socket 3 Destination IP Address (S3_DIPR0)
0x070D	(S3_DIPR1)
0x070E	(S3_DIPR2)
0x070F	(S3_DIPR3)
0x0710	Socket 3 Destination Port (S3_DPORT0)
0x0711	(S3_DPORT1)
0x0712	Socket 3 Maximum Segment Size (S3_MSSR0)
0x0713	(S3_MSSR1)
0x0714	Socket 3 Protocol in IP Raw mode (S3_PROTO)

Address	Register
0x0715	Reserved
~ 0x071F	
0x0720	Socket 3 TX Free Size (S3_TX_FSR0)
0x0721	(S3_TX_FSR1)
0x0722	Socket 3 TX Read Pointer (S3_TX_RR0)
0x0723	(S3_TX_RR1)
0x0724	Socket 3 TX Write Pointer (S3_TX_WR0)
0x0725	(S3_TX_WR1)
0x0726	Socket 3 RX Received Size (S3_RX_RSR0)
0x0727	(S3_RX_RSR0)
0x0728	Socket 3 RX Read Pointer (S3_RX_RR0)
0x0729	(S3_RX_RR1)
0x072A	Socket 3 RX Write Pointer (S3_RX_WR0)
0x072B	(S3_RX_WR1)
0x072C	Reserved
~ 0x07FF	

4. Register Descriptions

4.1. Common Registers

MR (Mode Register) [R/W] [0x0000] [0x00]¹

This Register is used for S/W Reset, memory test mode, ping block mode, PPPoE mode and Indirect bus I/F.

7	6	5	4	3	2	1	0
RST		MT	PB	PPPoE	LB	AI	IND

Bit	Symbol	Description
7	RST	S/W Reset If this bit is '1', internal register will be initialized. It will be automatically cleared with Reset.
6	Reserved	Reserved
5	MT	Memory Test Mode 0 : Disable memory test mode 1 : Enable memory test mode TX memory is used for data transmission. In this memory, only WRITE can be performed. At the RX memory, users can receive data and only READ can be performed. If a user wants to perform both of WRITE and READ in order to check operation status of TX memory and RX memory, the bit should be set as '1'. Memory Test Mode is used only for checking of TX/RX memory operation status. For the general usage, Memory Test Mode should be cleared first.
4	PB	Ping Block Mode 0 : Disable Ping block 1 : Enable Ping block If the bit is set as '1', there is no response to the Ping request.
3	PPPoE	PPPoE Mode 0 : Disable PPPoE mode 1 : Enable PPPoE mode If you are under the circumstance of PPPoE such as ADSL, you should set the bit as '1', and connect to PPPoE SERVER. For more detail, refer to 5.3 Usage of PPPoE SERVER.

¹ [Read/Write] [Address] [Reset value]

2	LB	<p>Little-endian / Big-endian ordering in Indirect Bus I/F</p> <p>0 : Big-endian ordering 1 : Little-endian ordering</p> <p>At the Indirect Bus I/F mode, Indirect address Register ordering is decided. For more detail, refer to 6.1.2. Indirect Bus IF Mode.</p>
1	AI	<p>Address Auto-Increment in Indirect Bus I/F</p> <p>0 : Disable auto-increment 1 : Enable auto-increment</p> <p>At the Indirect Bus I/F mode, if this bit is set as '1', the address will automatically increase by 1 whenever Read and Write are performed. For more detail, refer to 6.1.2 Indirect Bus IF Mode.</p>
0	IND	<p>Indirect Bus I/F mode</p> <p>0 : Disable Indirect bus I/F mode 1 : Enable Indirect bus I/F mode</p> <p>If this bit is set as '1', Indirect Bis I/F mode is used. For more detail, refer to 6. Application Information, 6.1.2. Indirect Bus IF Mode.</p>

GWR (Gateway IP Address Register) [R/W] [0x0001 – 0x0004] [0x00]

This Register sets up the default gateway address.

Ex) in case of "192.168.0.1"

0x0001	0x0002	0x0003	0x0004
192 (0xC0)	168 (0xA8)	0 (0x00)	1 (0x01)

SUBR (Subnet Mask Register) [R/W] [0x0005 – 0x0008] [0x00]

This Register sets up the subnet mask address.

Ex) in case of "255.255.255.0"

0x0005	0x0006	0x0007	0x0008
255 (0xFF)	255 (0xFF)	255 (0xFF)	0 (0x00)

SHAR (Source Hardware Address Register) [R/W] [0x0009 – 0x000E] [0x00]

This Register sets up the Source Hardware address.

Ex) In case of “00.08.DC.01.02.03”

0x0009	0x000A	0x000B	0x000C	0x000D	0x000E
0x00	0x08	0xDC	0x01	0x02	0x03

SIPR (Source IP Address Register) [R/W] [0x000F – 0x0012] [0x00]

This Register sets up the Source IP address.

Ex) in case of “192.168.0.3”

0x000F	0x0010	0x0011	0x0012
192 (0xC0)	168 (0xA8)	0 (0x00)	3 (0x03)

TOS (IP Type Of Service Register) [R/W] [0x0013] [0x00]

This Register sets up at the TOS Field of IP Header.

TTL (IP Time To Live Register) [R/W] [0x0014] [0x80]

This Register sets up at the TTL Field of IP Header.

IR (Interrupt Register) [R] [0x0015] [0x00]

This Register is accessed by the host processor to know the cause of an interrupt.

Any interrupt can be masked in the Interrupt Mask Register (IMR). The /INT signal retain low as long as any unmasked signal is set, and will not go high until all unmasked bits in this Register have been cleared.

7	6	5	4	3	2	1	0
CONFLICT	UNREACH	PPPoE	Reserved	S3_INT	S2_INT	S1_INT	S0_INT

Bit	Symbol	Description
7	CONFLICT	IP Conflict It is set as ‘1’, when there is ARP request with same IP address as Source IP address. This bit is cleared to ‘0’ only with Read action.
6	UNREACH	Destination unreachable W3150 will receive ICMP(Destination Unreachable) packet if not-existing Destination IP address is transmitted during UDP data transmission. (Refer to 5.2.2. UDP). In this case, the IP address and Port number will be saved in Unreachable IP Address (UIPR) and Unreachable Port Register (UPORT), and the bit will be set as ‘1’. This bit will be cleared to ‘0’ only with Read action.

5	PPPoE	PPPoE Close In the PPPoE Mode, if the PPPoE connection is closed, '1' is set. This bit will be cleared to '0' only with Read action.
4	Reserved	Reserved
3	S3_INT	Occurrence of Socket 3 Socket Interrupt It is set in case that interrupt occurs at the socket 3. For more detailed information of socket interrupt, refer to "Socket 3 Interrupt Register(S3_IR). This bit will be automatically cleared when S3_IR is cleared to 0x00.
2	S2_INT	Occurrence of Socket 2 Socket Interrupt It is set in case that interrupt occurs at the socket 2. For more detailed information of socket interrupt, refer to "Socket 2 Interrupt Register(S2_IR). This bit will be automatically cleared when S2_IR is cleared to 0x00.
1	S1_INT	Occurrence of Socket 1 Socket Interrupt It is set in case that interrupt occurs at the socket 1. For more detailed information of socket interrupt, refer to "Socket 1 Interrupt Register(S1_IR). This bit will be automatically cleared when S1_IR is cleared to 0x00.
0	S0_INT	Occurrence of Socket 0 Socket Interrupt It is set in case that interrupt occurs at the socket 0. For more detailed information of socket interrupt, refer to "Socket 0 Interrupt Register(S0_IR). This bit will be automatically cleared when S0_IR is cleared to 0x00.

IMR (Interrupt Mask Register) [R/W] [0x0016] [0x00]

The Interrupt Mask Register is used to mask interrupts. Each interrupt mask bit corresponds to a bit in the Interrupt Register (IR). If an interrupt mask bit is set, an interrupt will be issued whenever the corresponding bit in the IR is set. If any bit in the IMR is set as '0', an interrupt will not occur though the bit in the IR is set.

7	6	5	4	3	2	1	0
IM_IR7	IM_IR6	IM_IR5	Reserved	IM_IR3	IM_IR2	IM_IR1	IM_IR0

Bit	Symbol	Description
7	IM_IR7	IP Conflict Enable
6	IM_IR6	Destination unreachable Enable
5	IM_IR5	PPPoE Close Enable
4	Reserved	It should be set as '0'
3	IM_IR3	Occurrence of Socket 3 Socket Interrupt Enable
2	IM_IR2	Occurrence of Socket 2 Socket Interrupt Enable
1	IM_IR1	Occurrence of Socket 1 Socket Interrupt Enable

0	IM_IR0	Occurrence of Socket 0 Socket Interrupt Enable
---	--------	---

RTR (Retry Time-value Register) [R/W] [0x0017 – 0x0018] [0x07D0]

This register sets the period of timeout. Vaule 1 means 100us. The initial value is 2000(0x07D0). That will be set as 200ms.

Ex) For 400ms configuration, set as 4000(0x0FA0)

0x0017	0x0018
0x0F	0xA0

Re-transmission will occur when there is no response from the remote peer to the commands of CONNECT, DISCON, CLOSE, SEND, SEND_MAC and SEND_KEEP, or the response is delayed.

RCR (Retry Count Register) [R/W] [0x0019] [0x08]

This register sets the number of re-transmission. If retransmission occurs more than recorded number, Timeout Interrupt (TIMEOUT bit of Socket *n* Interrupt Register (Sn_IR) is set as '1') will occur.

RMSR(RX Memory Size Register) [R/W] [0x001A] [0x55]

This register assigns total 8K RX Memory to the socket.

7	6	5	4	3	2	1	0
Socket 3		Socket 2		Socket 1		Socket 0	
S1	S0	S1	S0	S1	S0	S1	S0

The memory size according to the configuration of S1, S0, is as below.

S1	S0	Memory size
0	0	1KB
0	1	2KB
1	0	4KB
1	1	8KB

Accordng to the value of S1 and S0, the memory is assigned to the sockets from socket 0 within the range of 8KB. If there is not enough memory to be assigned, the socket should not be used. The initial value is 0x55 and the memory is assined to 4 sockets respectively with 2K.

Ex) When setting as 0xAA, the memory should be assigned to each socket with 4KB.

However, the total memory size is 8KB. The memory is normally assigned to the socket 0 and 1, but not to the socket 2 and 3. Therefore, user should not use socket 2 and 3 absolutely.

Socket 3	Socket 2	Socket 1	Socket 0
0KB	0KB	4KB	4KB

TMSR(TX Memory Size Register) [R/W] [0x001B] [0x55]

This register is used in assigning total 8K TX Memory to sockets. Configuration can be done in the same way of RX Memory Size Register (RMSR). The initial value is 0x55 and assigned to 4 sockets respectively with 2K.

PATR (Authentication Type in PPPoE mode) [R] [0x001C-0x001D] [0x0000]

This register notifies authentication method that has been agreed at the connection with PPPoE Server. W3150 supports only two ways of PAP and CHAP.

Value	Authentication Type
0xC023	PAP
0xC223	CHAP

For more detail, refer to 5.3. Usage of PPPoE environment.

UIPR (Unreachable IP Address Register) [R] [0x002A – 0x002D] [0x00]

In case of data transmission by using UDP (refer to 5.2.2. UDP), if transmitting to not-existing IP address, ICMP (Destination Unreachable) packet will be received. In this case, that IP address and Port number will be respectively saved in the Unreachable IP Address Register(UIPR) and Unreachable Port Register(UPORT).

Ex) in case of “192.168.0.11”,

0x002A	0x002B	0x002C	0x002D
192 (0xC0)	168 (0xA8)	0 (0x00)	11 (0x0B)

UPOINT (Unreachable Port Register) [R] [0x002E – 0x002F] [0x0000]

Refer to Unreachable IP Address Register (UIPR)

Ex) In case of 5000(0x1388),

0x002E	0x002F
0x13	0x88

4.2. Socket Registers

Sn²_MR (Socket n Mode Register) [R/W] [0x0400, 0x0500, 0x0600, 0x0700] [0x00]³

This Register sets up socket option or protocol of the corresponding Socket.

7	6	5	4	3	2	1	0
		ND	ZC	P3	P2	P1	P0

Bit	Symbol	Description																																								
7	Reserved	Reserved																																								
6	Reserved	Reserved																																								
5	ND	<p>Use No Delayed ACK 0 : disable No Delayed ACK, 1 : enable No delayed ACK It is applied only in case of TCP. If this bit is set as '1', ACK packet is transmitted whenever receiving data packet from the peer. If this bit is cleared to '0', ACK packet is transmitted according to internal Timeout mechanism.</p>																																								
4	ZC	<p>Zero Chksum Enable 0 : disable Zero Chksum, 1 : enable Zero Chksum It is applied only in case of UDP. If this bit is set as '1', when the check sum of received UDP packets is correct or 0x00, receiving is normally processed. If this bit is cleared to '0', receiving is normally processed when check sum is correct.</p>																																								
3	P3	<p>Protocol Sets up corresponding Socket as TCP, UDP, IP RAW mode</p> <table border="1" style="width: 100%; text-align: center;"> <thead> <tr> <th>P3</th> <th>P2</th> <th>P1</th> <th>P0</th> <th>Meaning</th> </tr> </thead> <tbody> <tr> <td>0</td> <td>0</td> <td>0</td> <td>0</td> <td>Closed</td> </tr> <tr> <td>0</td> <td>0</td> <td>0</td> <td>1</td> <td>TCP</td> </tr> <tr> <td>0</td> <td>0</td> <td>1</td> <td>0</td> <td>UDP</td> </tr> <tr> <td>0</td> <td>0</td> <td>1</td> <td>1</td> <td>IP Raw</td> </tr> </tbody> </table> <p>* In case of socket 0, more MAC RAW and PPPoE mode exist.</p> <table border="1" style="width: 100%; text-align: center;"> <thead> <tr> <th>P3</th> <th>P2</th> <th>P1</th> <th>P0</th> <th>Meaning</th> </tr> </thead> <tbody> <tr> <td>0</td> <td>1</td> <td>0</td> <td>0</td> <td>MAC Raw</td> </tr> <tr> <td>0</td> <td>1</td> <td>0</td> <td>1</td> <td>PPPoE</td> </tr> </tbody> </table>	P3	P2	P1	P0	Meaning	0	0	0	0	Closed	0	0	0	1	TCP	0	0	1	0	UDP	0	0	1	1	IP Raw	P3	P2	P1	P0	Meaning	0	1	0	0	MAC Raw	0	1	0	1	PPPoE
P3	P2		P1	P0	Meaning																																					
0	0		0	0	Closed																																					
0	0		0	1	TCP																																					
0	0		1	0	UDP																																					
0	0	1	1	IP Raw																																						
P3	P2	P1	P0	Meaning																																						
0	1	0	0	MAC Raw																																						
0	1	0	1	PPPoE																																						
2	P2																																									
1	P1																																									
0	P0																																									

² n is socket number (0, 1, 2, 3).

³ [Read/Write] [address of socket 0, address of socket 1, address of socket 2, address of socket 3] [Reset value]

Sn_CR (Socket *n* Command Register) [R/W] [0x0401, 0x0501, 0x0601, 0x0701] [0x00]

This register utilized for socket initialization, close, connection establishment, connection termination, data transmitting and receiving commands. After performing the commands, the register value will be automatically cleared to 0x00.

Value	Symbol	Description
0x01	OPEN	It is used to initialize the socket. According to the vaule of Socket <i>n</i> Mode Register(<i>Sn_MR</i>), Socket <i>n</i> Status Register(<i>Sn_SSR</i>) value is changed to SOCK_INIT, SOCK_UDP, SOCK_IPRAW. For more detail, refer to 5. Functional Description.
0x02	LISTEN	It is only used in TCP mode. It changes the value of Socket <i>n</i> Status Register(<i>Sn_SSR</i>) to SOCK_LISTEN in order to wait for a connection request from any remote peer (Client). For more detail, refer to 5.2.1.1. SERVER.
0x04	CONNECT	It is only used in TCP mode. It sends a connection request to remote peer(SERVER). If the connection is failed, Timeout interrupt will occur. For more detail, refer to 5.2.1.2. CLIENT.
0x08	DISCON	It is only used in TCP mode. It sends connection termination request. If connection termination is failed, Timeout interrupt will occur. For more detail, refer to 5.2.1.1. SERVER. <i>* In case of using CLOSE command instead of DISCON, only the value of Socket <i>n</i> Status Register(<i>Sn_SSR</i>) is changed to SOCK_CLOSED without the connection termination process.</i>
0x10	CLOSE	It is used to close the socket. It changes the vaule of Socket <i>n</i> Status Register(<i>Sn_SSR</i>) to SOCK_CLOSED.
0x20	SEND	It transmits the data as much as the increased size of Socket <i>n</i> TX Write Pointer. For more detail, refer to Socket <i>n</i> TX Free Size Register (<i>Sn_TX_FSR</i>), Socket <i>n</i> TX Write Pointer Register(<i>Sn_TX_WR</i>), and Socket <i>n</i> TX Read Pointer Register(<i>Sn_TX_RR</i>) or 5.2.1.1. SERVER.
0x21	SEND_MAC	It is used in UDP mode. The basic operation is same as SEND. Normally SEND operation is needed Destination Hardware Address that is received in ARP(Address Resolution Protocol) process. But SEND_MAC uses Socket <i>n</i> Destination Hardware Address(<i>Sn_DHAR</i>) that is written by users without ARP process.

0x22	SEND_KEEP	It is only used in TCP mode. It checks the connection by sending 1byte data previously. If the connection is already terminated or Peer has no response, Timeout interrupt will occur.
0x40	RECV	Receiving is processed including the value of Socket <i>n</i> RX Read Pointer Register(<i>Sn_RX_RR</i>). For more detail, refer to Socket <i>n</i> RX Received Size Register (<i>Sn_RX_RSR</i>), Socket <i>n</i> RX Write Pointer Register(<i>Sn_RX_WR</i>), and Socket <i>n</i> RX Read Pointer Register(<i>Sn_RX_RR</i>) or 5.2.1.1. SERVER

Sn_IR (Socket *n* Interrupt Register) [R] [0x0402, 0x0502, 0x0602, 0x0702] [0x00]

This register is used for notifying connection establishment and termination, receiving data and Timeout. The values are cleared by reading this register.

7	6	5	4	3	2	1	0
Reserved	Reserved	Reserved	Reserved	TIMEOUT	RECV	DISCON	CON

Bit	Symbol	Description
7	Reserved	Reserved
6	Reserved	Reserved
5	Reserved	Reserved
4	Reserved	Reserved
3	TIMEOUT	It is set as '1' if Timeout occurs during connection establishment or termination and data transmission.
2	RECV	It is set as '1' if data is received.
1	DISCON	It is set as '1' if receive connection termination request or if connection termination is finished.
0	CON	It is set as '1' if connection is established.

Sn_SR (Socket n Status Register) [R] [0x0403, 0x0503, 0x0603, 0x0703] [0x00]

This register has the status value of socket. The main status is shown in the below diagram.

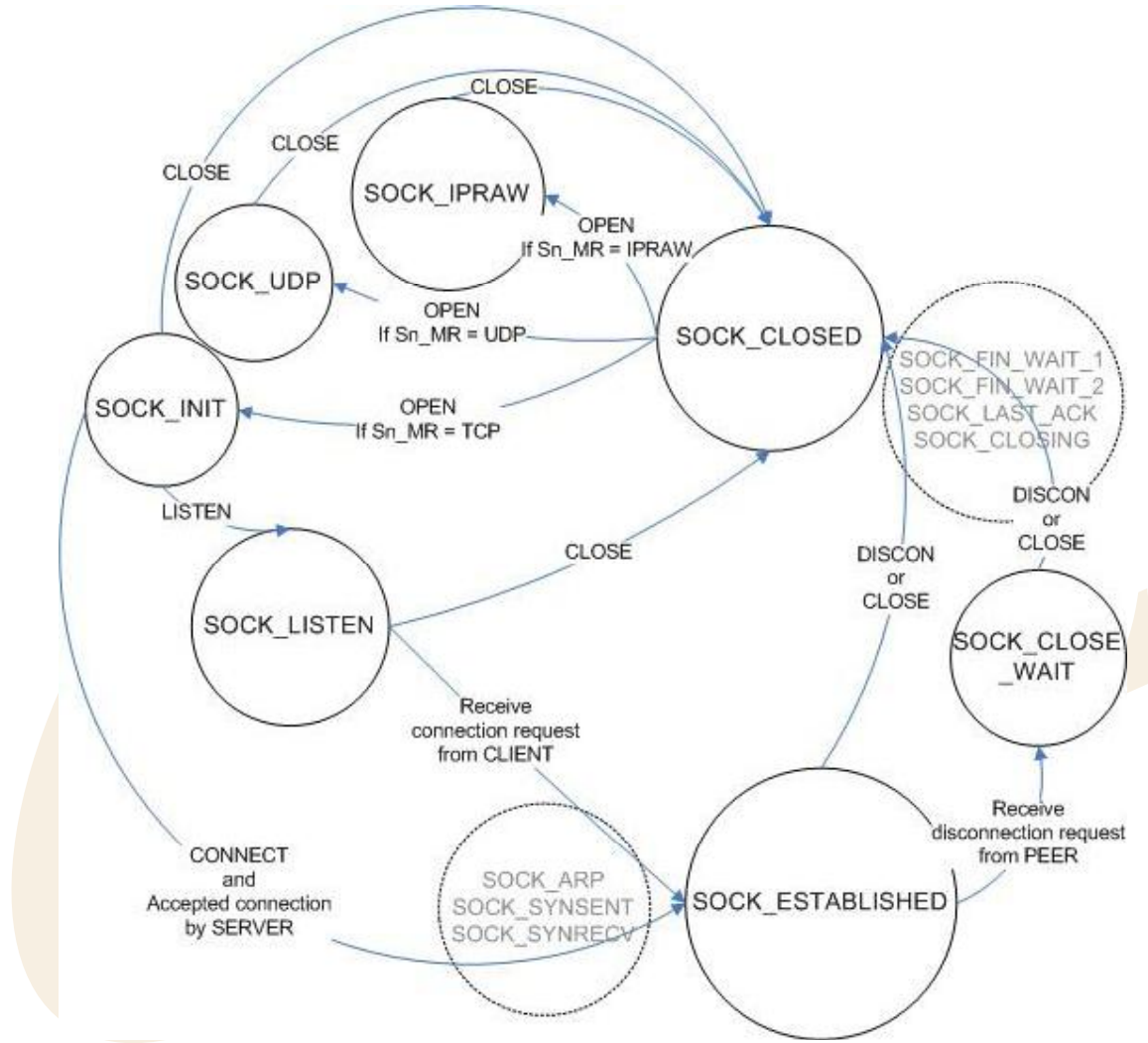

Value	Symbol	Description
0x00	SOCK_CLOSED	In case that OPEN commands are given to Sn_CR, Timeout interrupt is asserted or connection is terminated.
0x13	SOCK_INIT	In case that Sn_MR is set as TCP and OPEN commands are given to Sn_CR.
0x14	SOCK_LISTEN	In case that under the SOCK_INIT status, LISTEN commands are given to Sn_CR.
0x17	SOCK_ESTABLISHED	In case that connection is established.
0x1C	SOCK_CLOSE_WAIT	In case that connection termination request is received.

0x22	SOCK_UDP	In case that OPEN commands are given to S_n_CR when S_n_MR is set as UDP.
0x32	SOCK_IPRAW	In case that OPEN commands are given to S_n_CR when S_n_MR is set as IPRAW.

Below is shown in the status change, and does not need much attention.

Value	Symbol	Description
0x15	SOCK_SYNSENT	It is shown in case that CONNECT commands are given to Socket n Command Register(S_n_CR) at the SOCK_INIT status. It is automatically changed to SOCK_ESTABLISH when the connection is established.
0x16	SOCK_SYNRECV	It is shown in case that connection request is received from remote peer(CLIENT). It normally responds to the requests and changes to SOCK_ESTABLISH.
0x18	SOCK_FIN_WAIT1	It is shown in the process of connection termination. If the termination is normally processed or Timeout interrupt is asserted then automatically changed to SOCK_CLOSED.
0x19	SOCK_FIN_WAIT2	
0x1A	SOCK_CLOSING	
0x1B	SOCK_TIME_WAIT	
0x1D	SOCK_LAST_ACK	
0x11 0x21 0x31	SOCK_ARP	It is shown when ARP Request is sent in order to acquire Hardware Address of remote peer when it sends connection request in TCP mode or sends data in UDP mode. If ARP Reply is received, it changes to the status, SOCK_SYNSENT, SOCK_UDP or SOCK_ICMP, for next operation.

S_n_PORT (Socket n Source Port Register) [R/W] [0x0404–0x0405, 0x0504–0x0505, 0x0604–0x0605, 0x0704–0x0705] [0x00]

This Register sets the Source Port number for each Socket when using TCP or UDP mode, and the set-up needs to be made before executing the OPEN Command.

Ex) In case of Socket 0 Port = 5000(0x1388), configure as below,

0x0404	0x0405
0x13	0x88

Sn_DHAR (Socket *n* Destination Hardware Address Register) [R/W] [0x0406–0x040B, 0x0506–0x050B, 0x0606–0x060B, 0x0706–0x070B] [0x00]

This Register sets the Destination Hardware address of each Socket.

Ex) In case of Socket 0 Hardware address = 08.DC.00.01.02.10, configuration is as below,

0x0406	0x0407	0x0408	0x0409	0x040A	0x040B
0x08	0xDC	0x00	0x01	0x02	0x0A

Sn_DIPR (Socket *n* Destination IP Address Register) [R/W] [0x040C–0x040F, 0x050C–0x050F, 0x060C–0x060F, 0x070C–0x070F] [0x00]

This Register sets the Destination IP Address of each Socket to be used in setting the TCP connection. In active mode, IP address needs to be set before executing the Connect command. In passive mode, W3150 sets up the connection and then updates with peer IP internally.

Ex) In case of Socket 0 Destination IP address = 192.168.0.11, configure as below.

0x040C	0x040D	0x040E	0x040F
192 (0xC0)	168 (0xA8)	0 (0x00)	11 (0x0B)

Sn_DPORT (Socket *n* Destination Port Register) [R/W] [0x0410–0x0411, 0x0510–0x0511, 0x0610–0x0611, 0x0710–0x0711] [0x00]

This Register sets the Destination Port number of each Socket to be used in setting the TCP connection. In active mode, port number needs to be set before executing the Connect command. In passive mode, W3150 sets up the connection and then updates with peer port number internally.

Ex) In case of Socket 0 Destination Port = 5000(0x1388), configure as below,

0x0410	0x0411
0x13	0x88

Sn_MSS (Socket *n* Maximum Segment Size Register) [R/W] [0x0412–0x0413, 0x0512–0x0513, 0x0612–0x0613, 0x0712–0x0713] [0x00]

This Register is used for MSS (Maximum Segment Size) of TCP, and the Register displays MSS set by the other party when TCP is activated in Passive Mode.

Ex) In case of Socket 0 MSS = 1460(0x05B4), configure as below,

0x0412	0x0413
0x05	0xB4

Sn_PROTO (Socket *n* IP Protocol Register) [R/W] [0x0414, 0x0514, 0x0614, 0x0714] [0x00]

This IP Protocol Register is used to be set up the Protocol Field of IP Header when executing the IP Layer RAW Mode. There are several protocol numbers defined in advance by registering to IANA. For the overall list of upper level protocol identification number that IP is using, refer to online documents of IANA (<http://www.iana.org/assignments/protocol-numbers>).

Ex) Internet Control Message Protocol (ICMP) = 0x01, Internet Group Management Protocol = 0x02

Sn_TX_FSR (Socket *n* TX Free Size Register) [R] [0x0420-0x0421, 0x0520-0x0521, 0x0620-0x0621, 0x0720-0x0721] [0x0800]

This register notifies the information of data size that user can transmit. For data transmission, user should check this value first and control the size of transmitting data. *When checking this register, user should read upper byte first and lower byte later to get the correct value.*

Total size can be decided according to the value of TX Memory Size Register. In the process of transmission, it reduces by the size of transmitting data, and automatically increases after transmission finished.

Sn_TX_RR (Socket *n* TX Read Pointer Register) [R] [0x0422-0x0423, 0x0522-0x0523, 0x0622-0x0623, 0x0722-0x0723] [0x0000]

This register shows the address that transmission is finished at the TX Memory. With the SEND command of Socket *n* Command Register, it transmits data from current Sn_TX_RR to Sn_TX_WR and automatically changes after transmission is finished. Therefore, after transmission is finished, Sn_TX_RR and Sn_TX_WR will have same value. *When checking this register, read upper byte first and lower byte later to get the proper value.*

Sn_TX_WR (Socket *n* TX Write Pointer Register) [R/W] [0x0424-0x0425, 0x0524-0x0525, 0x0624-0x0625, 0x0724-0x0725] [0x0000]

This register means the address to write next data to transmit. It is used during data transmission. User can write the data to transmit from this address.

However, only with the data write operation, it is not possible to know the data size to transmit internally. So, increase the register value as much as the already written data size, and give SEND command to Socket *n* Command Register. *When checking this register, read the upper byte first and lower byte later to get the correct value.* If data is just written in the TX Memory, but the value of register is not increased, data transmission does not occur even with SEND command to Sn_CR.

Sn_RX_RSR (RX Received Size Register) [R] [0x0426-0x0427, 0x0526-0x0527, 0x0626-0x0627, 0x0726-0x0727] [0x0000]

This register notifies the data size received in RX Memory. As this value is internally calculated with the values of *Sn_RX_RR* and *Sn_RX_WR*, it is automatically changed by RECV command of Socket *n* Command Register(*Sn_CR*) and receiving data for remote peer. *When checking this register, read the upper byte first and lower byte later to get the correct value.* The total size of this value can be decided according to the value of RX Memory Size Register.

Sn_RX_RR (Socket *n* RX Read Pointer Register) [R/W] [0x0428-0x0429, 0x0528-0x0529, 0x0628-0x0629, 0x0728-0x0729] [0x0000]

This register indicates start address of received data. It is used during data receiving process. User can read the received data and process it from this address.

However, only with data read operation, it is not possible to know if receiving has been internally proceeded or not. So, after reading data, increase the register value as much as reading data size, and give RECV command to Socket *n* Command Register(*Sn_CR*). *When checking this register, read upper byte first and lower byte later to get the correct value.* When increasing as much as receiving data size, do not increase more than received data size. Check received size (*Sn_RX_RSR*) first for the process.

Sn_RX_WR (Socket *n* RX Write Pointer Register) [R] [0x042A-0x042B, 0x052A-0x052B, 0x062A-0x062B, 0x072A-0x072B] [0x0000]

This register indicates the last address of received data in RX Memory. Internally, this value is automatically changed by receiving data from remote peer. In case the receiving process is normally processed, *Sn_RX_RR* and *Sn_RX_WR* will have same value. *When checking this register, read the upper byte first and lower byte later to get the correct value.*

5. Functional Description

By setting some register and memory operation, W3150 provides internet connectivity. This chapter describes how it can be operated.

5.1. Initialization

Below register is for basic network configuration information to be configured according to the network environment.

1. Gateway Address Register (GAR)
2. Source Hardware Address Register (SHAR)
3. Source IP Address Register (SIPR)
4. Subnet Mask Register (SUBR)

The Source Hardware Address Register (SHAR) is the H/W address to be used in MAC layer, and can be used with the address that manufacturer has been assigned. The MAC address can be assigned from IEEE. For more detail, refer to IEEE homepage.

5.2. Data communication

Data communication is available through TCP or UDP. In order to select it, configure protocol field of Socket n Mode Register (S_n_MR) of the communication sockets (W3150 supports total 4 sockets) as TCP(0x01) or UDP(0x02).

5.2.1. TCP

TCP is connection oriented communication method that will establish connection in advance and deliver the data through the connection by using IP Address and Port number of the systems. There are two methods to establish the connection. One is SERVER mode(passive open) that is waiting for connection request. The other is CLIENT mode(active open) that sends connection request to SERVER.

5.2.1.1. SERVER mode

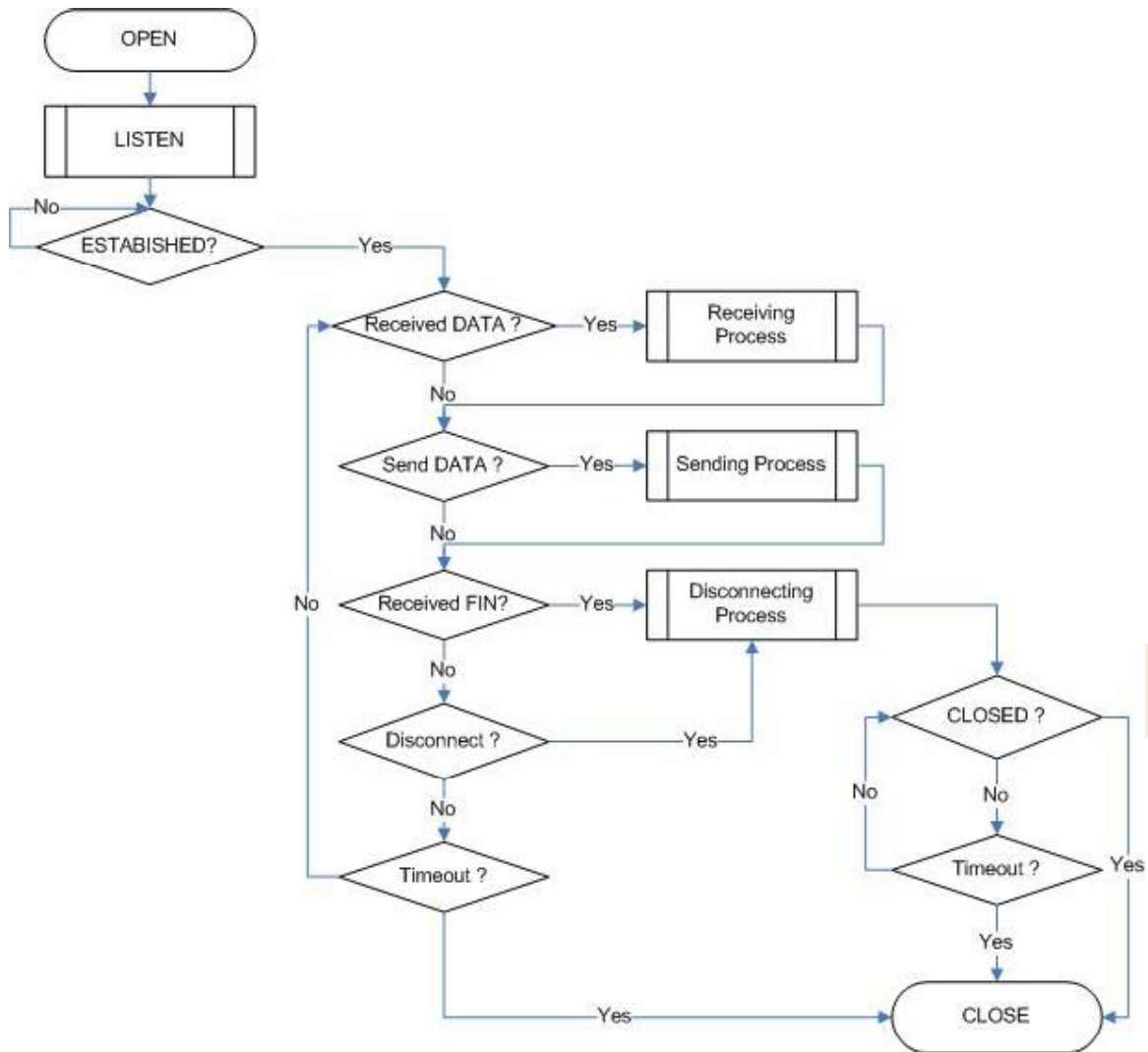

■ Socket Initialization

It initializes the socket as TCP,

1. It sets protocol field of Socket *n* Mode Register (*Sn_MR*) as TCP (0x01).
2. It sets user defined value at the Socket *n* Source Port Register (*Sn_PORT*).
3. Set the OPEN value to Socket *n* Command Register (*Sn_CR*).
4. Check if the value of Socket *n* Socket Status Register(*Sn_SSR*) is SOCK_INIT or not. If not, Set the CLOSE value to Socket *n* Command Register (*Sn_CR*), and try from the first.

■ LISTEN

In order to wait for a connection request.

1. Set the LISTEN value to Socket *n* Command Register(*Sn_CR*).
2. Check if the value of Socket *n* Socket Status Register(*Sn_SSR*) is SOCK_LISTEN or not. If not, go back to the Socket Initialization step.

■ ESTABLISHED ?

If received connection request of remote peer (the status of SOCK_SYNRCV), W3150 sends ACK packet and changes to SOCK_ESTABLISHED status. This status can be checked as below.

- Check if CON bit value of Socket *n* Interrupt Register(*Sn_IR*) is '1'. (In this case, if the interrupt of Socket *n* is activated, interrupt occurs. Refer to Interrupt Register (IR), Interrupt Mask Register (IMR) and Socket *n* Interrupt Register (*Sn_IR*.)
- Or Check if the value of Socket *n* Socket Status Register(*Sn_SSR*) is SOCK_ESTABLISHED.

As connection is established, data transmission and receipt can be performed.

■ ESTABLISHED : Received Data ?

Check as below to know if data is received from remote peer or not.

- Check if the value of Socket *n* RX Received Size Register(*Sn_RX_RSR*) is 0x00.
- Or Check if RECV bit value of Socket *n* Interrupt Register(*Sn_IR*) is '1'. (In this case if the interrupt of Socket *n* is activated, interrupt occurs. Refer to Interrupt Register (IR), Interrupt Mask Register (IMR), Socket *n* Interrupt Register (*Sn_IR*.)

■ ESTABLISHED : Receiving Process

Received data can be processed as below.

1. Read the value of Socket *n* RX Received Size Register(*Sn_RX_RSR*) and find out the size of received data.
2. Read the value of Socket *n* RX Read Pointer Register(*Sn_RX_RR*) and find out starting address of received data.
3. With the information of above 1 and 2, read received data in the RX Memory.
4. Increase the value of Socket *n* RX Read Pointer Register(*Sn_RX_RR*) to the size of above 1.
5. Give RECV command to Socket *n* Command Register(*Sn_CR*) for receiving next data.

■ ESTABLISHED : Send DATA ? / Sending Process

The sending procedure is as below.

1. Read the value of Socket n TX Free Size Register ($S_n_TX_FSR$) and find out receivable TX Memory free size. If $S_n_TX_FSR$ is 0, user should wait for a while and then retry it.
2. Read the value of Socket n TX Write Pointer Register ($S_n_TX_WR$) and find out starting address to write the data to send.
3. With the information of above 1 and 2, write the data to transmit to TX Memory. The size of transmitting data should not be larger than the value of Socket n TX Free Size Register ($S_n_TX_FSR$) of above 1.
4. Increase Socket n TX Write Pointer Register($S_n_TX_WR$) as much as the size of sent data.
5. Go to the next step when the value of Socket n Command Register(S_n_CR) becomes 0x00. It is the process to check if previous SEND command is on performing.
6. Give SEND commands to Socket n Command Register(S_n_CR).

■ ESTABLISHED : Received FIN?

Waiting for a connection termination request from remote peer.

It can be checked as below if it received connection termination request of remote peer.

- Check if DISCON value of Socket n Interrupt Register(S_n_IR) is '1'. (In this case if the interrupt of Socket n is activated, interrupt occurs. Refer to Interrupt Register (IR), Interrupt Mask Register (IMR), Socket n Interrupt Register (S_n_IR .)
- Or Check if the value of Socket n Socket Status Register(S_n_SSR) is SOCK_CLOSE_WAIT.

■ ESTABLISHED : Disconnect ? / Disconnecting Process

Check if user requests to terminate this connection.

To terminate the connection, proceed as below,

1. Give DISCON commands to Socket n Command Register(S_n_CR).

■ ESTABLISHED : CLOSED ?

No connection state at all. It can be checked as below,

- Check if DISCON value of Socket n Interrupt Register(S_n_IR) is '1'. (In this case if the interrupt of Socket n is activated, interrupt occurs. Refer to Interrupt Register (IR), Interrupt Mask Register (IMR), Socket n Interrupt Register (S_n_IR .)
- Or Check if the value of Socket n Socket Status Register(S_n_SSR) is SOCK_CLOSED.

■ ESTABLISHED : Timeout

In case that connection is closed due to the error of remote peer during data receiving or connection closing process, data transmission can not be normally processed. At this time Timeout occurs after some time.

1. Check if TIMEOUT bit value of Socket n Interrupt Register(S_n_IR) is '1'. (In this case, if interrupt of Socket n is activated, interrupt occurs Refer to Interrupt Register (IR), Interrupt Mask Register (IMR), and Socket n Interrupt Register.)

■ Socket Close

This process should be processed in case that connection is closed after data exchange, socket should be closed with Timeout occurrence, or forcible disconnection is necessary due to abnormal operation.

1. Give CLOSE commands to Socket n Command Register(S_n_CR).

5.2.1.2. CLIENT mode

Whole process is shown as below.

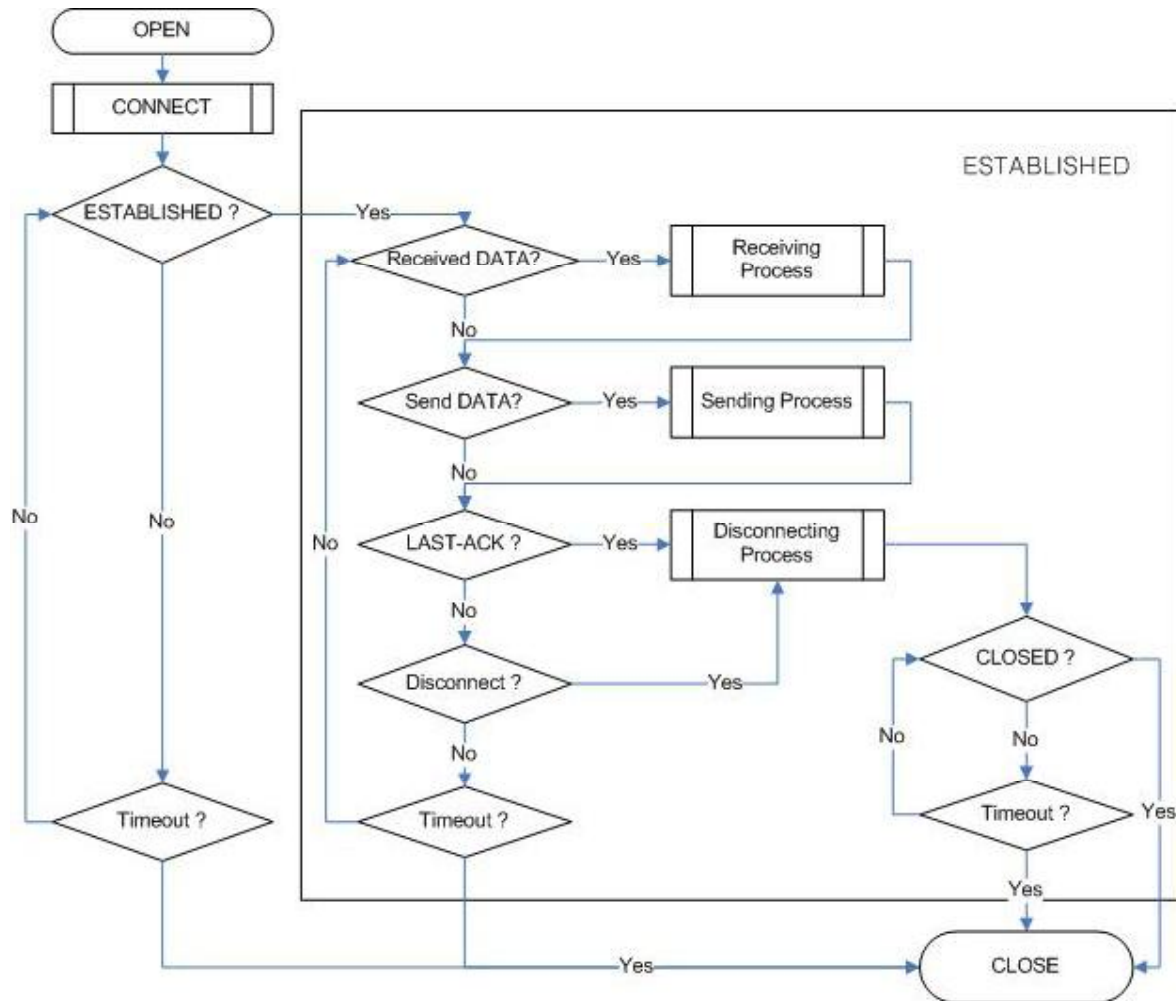

■ Socket Initialization

Refer to 5.2.1.1 SERVER (The operation is same as SERVER).

■ CONNECT

Sends connection request to remote HOST(SERVER) is as below.

1. Write the value of IP Address and Port of remote peer(SERVER) to the Socket *n* Destination IP Address Register(*Sn_DIPR*), Socket *n* Destination Port Register(*Sn_DPORT*).
2. Give CONNECT command to the Socket *n* Command Register(*Sn_CR*).

■ ESTABLISHED ?

The connection is established. It can be checked as below,

- Check if CON bit value of Socket *n* Interrupt Register(*Sn_IR*) is '1' or not. (In this case, if interrupt of Socket *n* is activated, interrupt occurs. Refer to Interrupt Register (IR), Interrupt Mask Register (IMR), and Socket *n* Interrupt Register (*Sn_IR*).
- Or Check if the value of Socket *n* Socket Status Register(*Sn_SSR*) is SOCK_ESTABLISHED.

■ Timeout

Socket is closed as Timeout occurs as there is not response from remote peer. It can be checked as below.

- Check the value of TIMEOUT bit of Socket *n* Interrupt Register(*Sn_IR*) is '1'. (In this case, if the interrupt of Socket *n* is activated, interrupt occurs. Refer to Interrupt Register (IR), Interrupt Mask Register (IMR), Socket *n* Interrupt Register (*Sn_IR*.)
- Or Check if the value of Socket *n* Socket Status Register(*Sn_SSR*) is SOCK_CLOSED.

■ ESTABLISHED

Refer to 5.2.1.1. SERVER (The operation is same as SERVER mode)

5.2.2. UDP

UDP provides unreliable and connectionless datagram transmission structure. It processes data without connection establishment that TCP does. Therefore, UDP message can be lost, overlapped, reversed. As packets can arrive faster, recipient can not process all of them. In this case, user application should guarantee the reliability of data transmission. UDP transmission can be proceeded as below,

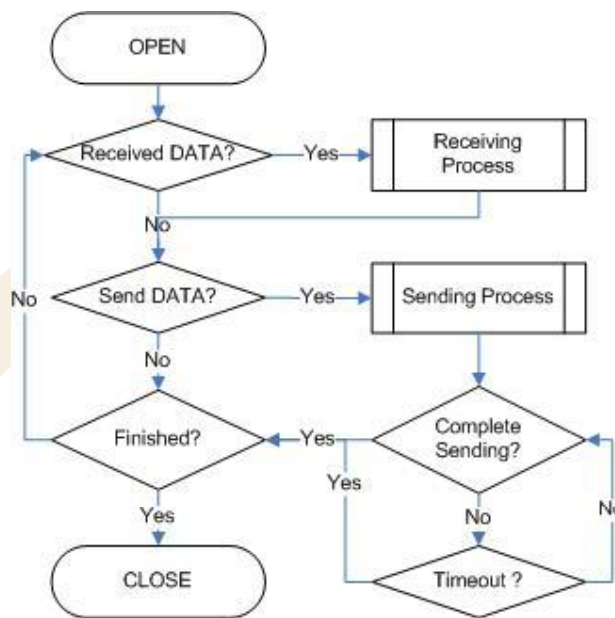

■ Socket Initialization

Initialize the socket as UDP.

1. Set the protocol field of Socket *n* Mode Register (*Sn_MR*) as UDP(0x02).
2. Set the user defined value to the Socket *n* Source Port Register (*Sn_PORT*).
 ※ The value of Source Port can be appropriately delivered when remote HOST knows it.
3. Give OPEN command to Socket *n* Command Register (*Sn_CR*).
4. Check if the value of Socket *n* Socket Status Register(*Sn_SSR*) is SOCK_UDP. If not, try from the first.

■ Received DATA?

It can be checked as below if data is received from remote peer.

- Check if the value of Socket *n* RX Received Size Register (*Sn_RX_RSR*) is 0x00.
- Or Check if the RECV value of Socket *n* Interrupt Register (*Sn_IR*) is '1'. (In this case, if the interrupt of Socket *n* is activated, interrupt occurs. Refer to Interrupt Register (IR), Interrupt Mask Register (IMR), Socket *n* Interrupt Register (*Sn_IR*.)

■ Receiving Process

Received data can be processed as below.

1. In case of UDP, 8byte header is attached to receiving data. The structure of the header is as below.

IP Address (4)	Port (2)	Data size (2) (*data size except for 8byte of header)
----------------	----------	---

2. Find out data starting address by reading the value of Socket *n* RX Read Pointer Register(*S_n_RX_RR*).
3. At the RX Memory, read header information (8byte) from the address of above '2'.
4. At the header, find out the IP address, Port, Data size from remote peer.
5. At the RX Memory, read the received data as much as the data size of above '4'. The starting address is (value of above '2'. + 8).
6. Increase the value of Socket *n* RX Read Pointer Register(*S_n_RX_RR*) as much as header size and the data size (value of Data size field + 8).
7. Give RECV command to the Socket *n* Command Register(*S_n_CR*) for receiving next data.

■ Send Data? / Sending Process

Data transmission process is as below.

1. Write the IP address and Port information of remost peer on the Socket *n* Destination IP Address Register(*S_n_DIPR*), Socket *n* Destination Port Register(*S_n_DPORT*).
2. Read the value of Socket *n* TX Free Size Register(*S_n_TX_FSR*), and find out TX Memory free size.
3. Read the value of Socket *n* TX Write Pointer Register(*S_n_TX_WR*), and find out starting address to write data to transmit.
4. With the information of above '2'. and '3', write data to transmit to TX Memory. In this case, transmitting data size should not be larger than the value of Socket *n* TX Free Size Register(*S_n_TX_FSR*) of above '1'.
5. Increase the value of Socket *n* TX Write Pointer Register(*S_n_TX_WR*) as much as the size of transmitting data.
6. Give SEND command to Socket *n* Command Register(*S_n_CR*).

■ Complete Sending?

The sending completion should be checked after SEND command.

1. If the value of Socket *n* Command Register(*S_n_CR*) becomes 0x00, transmission is completed.

■ Timeout

Timeout occurs if there is not remote peer or data transmission is not proceeded due to abnormal network. It can be checked as below.

1. Check if TIMEOUT bit value of Socket n Interrupt Register(S_n_IR) is '1'. (In this case, if the interrupt of Socket n is activated, interrupt occurs. Refer to Interrupt Register (IR), Interrupt Mask Register (IMR), Socket n Interrupt Register (S_n_IR .)

■ Finished? / Socket Close

If all the actions are finished, close the socket.

1. Give CLOSE commands to Socket n Command Register(S_n_CR).



5.2.3. IP raw

IP Raw mode can be utilized if transport layer protocol of some ICMP or IGMP that W3150 does not support, needs to be processed.

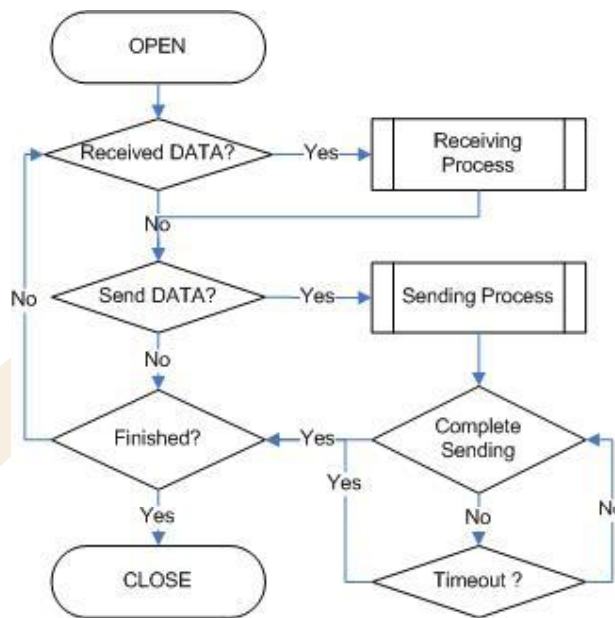

■ Socket Initialization

It initializes the socket as IP raw.

1. Set the protocol field of Socket n Mode Register(S_n_MR) as IP raw(0x03).
2. Assign to Socket n IP Protocol Register (S_n_PROTO) the vaule that you want.
 - ※ The value of Protocol is the value used in Protocol Field of IP Header.
 - For the list of protocol identification number of upper classification, refer to on line documents of IANA (<http://www.iana.org/assignments/protocol-numbers>).
3. Give OPEN command to Socket n Command Register(S_n_CR).
4. Check if the value of Socket n Socket Status Register(S_n_SSR) is SOCK_IPRAW. If not, try from the first.

■ Received DATA?

It can be checked as below if data is received from remote peer.

- Check the value of Socket n RX Received Size Register($S_n_RX_RSR$) is 0x00 or not.
- Or Check the RECV bit vaule of Socket n Interrupt Register(S_n_IR) is '1' or not (If interrupt of Socket n is activated, interrupt will occur. Refer to Interrupt Register (IR), Interrupt Mask Register (IMR), and Socket n Interrupt Register (S_n_IR).

■ Receiving Process

Data receipt process is as below.

1. In case of IP raw, 6byte header is attached to the data received. The header structure is as below.

IP Address (4)	Data Size (2) (*Data size except for 6 bytes of header)
----------------	---

2. Read the value of Socket n RX Read Pointer Register($S_n_RX_RR$), and find out the starting address of received data.
3. Read the header information (6byte) from the address figured out at above '2' of RX Memory.
4. Get the IP address of remote peer and data size from the header.
5. Read the received data from the RX Memory as much as the data size of above '4'. The starting number is the (value of above '2' +6).
6. Increase the value of Socket n RX Read Pointer Register($S_n_RX_RR$) as much as "Value of Data size field + 6"
7. Give RECV command to Socket n Command Register(S_n_CR).

■ Send DATA? / Sending Process

Data transmission process is as below,

1. Write the IP address information of the remote peer on Socket n Destination IP Address Register(S_n_DIPR).
2. Find out TX Memory free size by reading the value of Socket n TX Free Size Register ($S_n_TX_FSR$).
3. Read the value of Socket n TX Write Pointer Register($S_n_TX_WR$) and find out the starting address to write data to transmit.
4. Write data to transmit on TX Memory with the information of above '2' & '3'. The size of transmitting data should not be larger than the value of Socket n TX Free Size Register($S_n_TX_FSR$).
5. Increase the value of Socket n TX Write Pointer Register($S_n_TX_WR$) as much as the size of transmitted data.
6. Give SEND commands to Socket n Command Register(S_n_CR).

■ Complete Sending

■ Timeout

■ Finished? / Socket Closed

Next actions are same as UDP. Refer to 5.2.2 UDP.

5.3. Usage of PPPoE environment

As like ADSL, at the PPPoE, communication is available after acquiring the network information by connection with PPPoE SERVER. In this case, user doesn't need to assign the value of GAR, SUBR, and IPR. For more details, refer to follows. PPPoE(RFC 2516), PAP mechanism(RFC 1334), CHAP mechanism(RFC 1994).

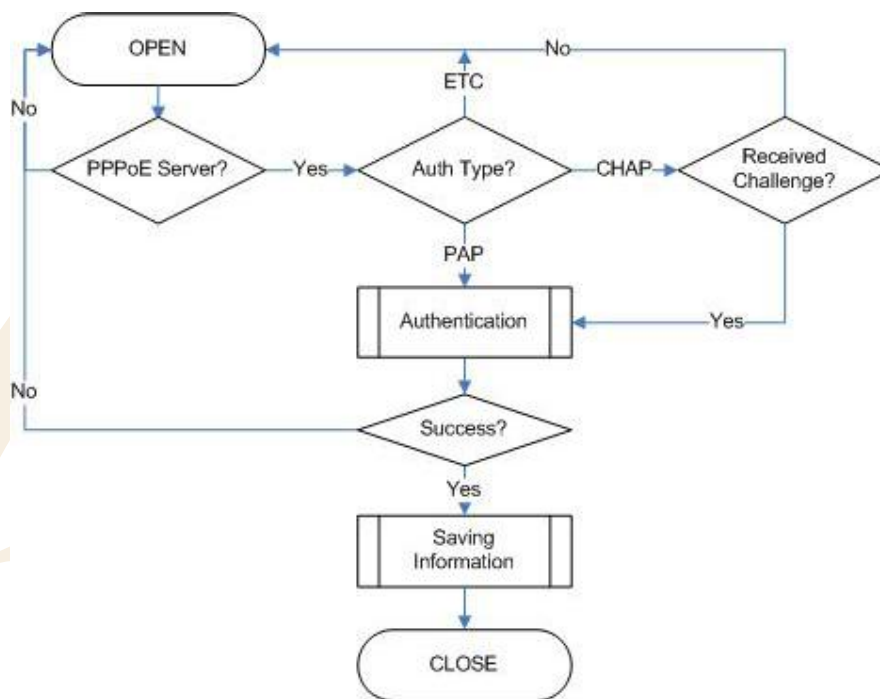

■ Socket Initialization

Initialize the socket as PPPoE and try the connection to PPPoE SERVER.

1. Set the PPPoE bit of Mode Register(MR) as 1.
2. Set the protocol field of Socket 0 Mode Register(S0_MR) as PPPoE(0x05). **Be sure to use Socket 0. Other sockets are not supported.**
3. Write 0XFF on the Socket 0 Destination Hardware Address Register(S0_DHAR).
4. Give OPEN command to Socket 0 Command Register(S0_CR).
5. For the connection with PPPoE SERVER, give CONNECT command to the Socket 0 Command Register(S0_CR).

■ PPPoE SERVER?

It should be checked if it is connected with PPPoE SERVER as below.

1. Check if RECV value of Socket n Interrupt Register(S_n_IR) is '1'. (In this case if the interrupt of Socket n is activated, interrupt occurs. Refer to Interrupt Register (IR), Interrupt Mask Register (IMR), Socket n Interrupt Register (S_n_IR .)

■ Auth Type?

Authentication type can be checked as below.

1. Read the value of Authentication Type Register in PPPoE(PATR).
2. If PATR value is 0xC023, PAP process is performed, if 0xC223, CHAP process is done.

■ Received Challenge?

In case of CHAP, Challenge value from PPPoE SERVER can be used for authentication process.

1. Data structure received in RX Memory is as below.

0xC2	0x23	0x01	CHAL_ID(1)	Don't care (2)	CHAL_LEN(1)	CHALLENGE(variable)
------	------	------	------------	----------------	-------------	---------------------

2. Read the value of Socket 0 RX Read Pointer Register($S_n_RX_RR$), and find out the starting address of data received.
3. Read the value of Socket 0 RX Received Size Register($S_n_RX_RSR$), and find out the size of data received.
4. Read 7bytes from the address of above '2'.
5. Save CHAL_ID and CHAL_LEN.
6. Read and save the CHALLENGE value as much as CHAL_LEN of above 4.. The starting address is (value of above 2. + 7)
7. Increase the value of Socket n RX Read Pointer Register($S_n_RX_RR$) as much as the received data of above 3..
8. Give RECV command to Socket n Command Register(S_n_CR).

■ Authentication

In case of PAP,

1. Read the value of Socket 0 TX Write Pointer Register ($S_0_TX_WR$), and find out the starting address to write data to transmit.
2. Write the data in below form on the TX Memory.

ID length (1)	ID (variable)	Password length (1)	Password (variable)
---------------	---------------	---------------------	---------------------
3. Increase the value of Write Pointer Register ($S_0_TX_WR$) as much as the data size (1+ID_LEN+1+PWD_LEN).
4. Give SEND commands to Socket n Command Register(S_n_CR).

In case of CHAP,

1. Make 64 byte array of below structure with the information of CHAL_ID, CHALLENGE and Password.

<----- 64 byte ----->

CHAL_ID(1)	PWD(variable)	CHALLENGE(variable)	0x80	0x00 Padding
------------	---------------	---------------------	------	--------------

2. Perform the MD5 process with the array of above 1, and make the authentication code of 16byte.
3. Read the value of Socket 0 TX Write Pointer Register(S0_TX_WR) and find out starting address of data to transmit.
4. Write the data in below form on the TX Memory.

0x10	Authentication code(16)	ID(variable)
------	-------------------------	--------------

5. Increase the value of Socket 0 TX Write Pointer Register (S0_TX_WR) as much as the data size (1 + the length of authentication code(16) + length of ID).
6. Give SEND command to Socket n Command Register(Sn_CR).

■ Success?

It can be checked as below if user authentication is succeeded or not.

1. If the CON bit value of Socket 0 Interrupt Register(S0_IR) is '1', authentication is succeeded. (In this case, if interrupt of Socket 0 is activated, interrupt will occur. Refer to Interrupt Register (IR), Interrupt Mask Register (IMR), and Socket 0 Interrupt Register (S0_IR).)
2. If TIMEOUT bit value of Socket 0 Interrupt Register(S0_IR) is '1', authentication is failed. (In this case, if interrupt of Socket 0 is activated, interrupt will occur. Refer to Interrupt Register (IR), Interrupt Mask Register (IMR), and Socket n Interrupt Register (Sn_IR))
3. In case of authentication success, information will be saved in PPPoE corresponding register(Refer to "Saving Information") and connection will be closed.
4. In case of authentication failure, it checks if there is another authentication method except for PAP or CHAP, and if the information of ID and Password is correct, and tries from the first step. If the cause of failure is another authentication, W3150 can not support.

■ Saving Information

As PPPoE connection is succeeded, PPPoE related information will be saved.

1. Read the value of Socket 0 Destination Hardware Address Register(S0_DHAR) and save it to a variable as PPPoE SERVER Hardware Address.
2. Read the value of Socket 0 Destination Port Register(S0_DPORT) and save it to a variable as PPPoE Session ID.
3. Those valued can be used in the process of PPPoE disconnection.

■ Socket Close

All the process is completed, close the socket.

1. Give CLOSE command to Socket 0 Command Register(S0_CR).
- ※ In order to use socket 0 as other modes(TCP, UDP, IP Raw, MAC Raw), CLOSE command should be given. DISCONNECT command instead of CLOSE, should not be given. If Socket 0 Mode is PPPoE, DISCON commands will perform PPPoE SERVER disconnection. Therefore, with this commands, all the sockets can not perform normal communication. For the normal action, PPPoE connection should be performed from the first step.

* PPPoE connection termination can be performed as below.

1. Set the PPPoE bit of Mode Register(MR) as 1.
2. Set the protocol field of Socket 0 Mode Register(S0_MR) as PPPoE(0x05). Be sure to use Socket 0. Other sockets are not supported.
3. Write PPPoE SERVER Hardware Address saved in a variable to Socket 0 Destination Hardware Address Register(S0_DHAR).
4. Write PPPoE Session ID saved in a variable to the Socket 0 Destination Port Register.
5. Give OPEN command to Socket 0 Command Register(S0_CR).
6. Give DISCON command to Socket 0 Command Register(S0_CR).

* After PPPoE authentication, TCP communication, UDP communication, and IP_RAW communication are same as 5.2.1. TCP, 5.2.2. UDP, and 5.2.3. IP raw.

6. Application Information

For the communication with MCU, W3150 provides Direct Bus I/F and Indirect Bus I/F mode. For the communication with Ethernet PHY, MII is used.

6.1. Direct Bus I/F Mode.

Direct Bus I/F mode uses 15bit address line and 8bit data line, /CS, /RD, /WR, /INT.

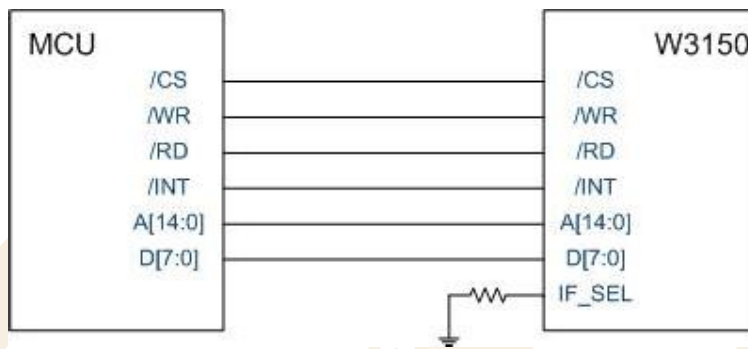

6.2. Indirect Bus I/F Mode.

Indirect Bus I/F mode uses 2bit address line and 8bit data line, /CS, /RD, /WR, /INT.

[14:2], other address lines should process Pull-down.

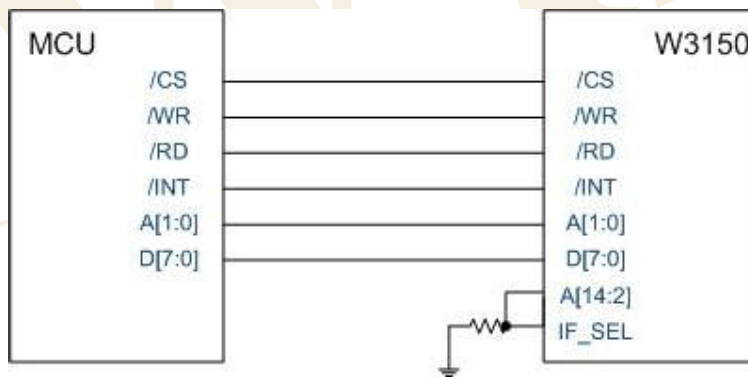

Indirect bus I/F mode related register is as below.

Value	Symbol	Description
0x00	MR	It performs the selection of Indirect bus I/F mode, Little/Big endian, and address automatic increase. Refer to 4. Register Description" for more detail.

0x01	IDM_AR0	Indirect bus I/F mode address Register MSB/LSB can be decided by LB bit of MODE Register. 1. In case that LB bit is set to 0 <div style="display: flex; justify-content: space-around; align-items: center;"> 0x01 0x02 </div> <table border="1" style="margin: 0 auto; text-align: center;"> <tr> <td>IDM_AR0 : MSB</td> <td>IDM_AR1 : LSB</td> </tr> </table> 2. In case that LB bit is set to 1 <div style="display: flex; justify-content: space-around; align-items: center;"> 0x01 0x02 </div> <table border="1" style="margin: 0 auto; text-align: center;"> <tr> <td>IDM_AR0 : LSB</td> <td>IDM_AR1 : MSB</td> </tr> </table>	IDM_AR0 : MSB	IDM_AR1 : LSB	IDM_AR0 : LSB	IDM_AR1 : MSB
IDM_AR0 : MSB	IDM_AR1 : LSB					
IDM_AR0 : LSB	IDM_AR1 : MSB					
0x02	IDM_AR1					
0x03	IDM_DR	Indirect bus I/F mode data Register				

In order to read or write the internal register or internal TX/RX Memory,

1. Write the address to read or write on IDM_AR0,1.
2. Read or Write IDM_DR.

In order to read or write the data on the sequential address, set AI bit of MR(Mode Register). With this, user performs above 1 only one time. Whenever reading or writing IDM_DR, IDM_AR value increases by 1 automatically. So, the value can be processed on the sequential address just by continuous reading or writing of IDM_DR.

6.3. MII (Media Independent Interface)

The MII handles the data transfer between the W3150 and the Physical Layer Device.

The MII is composed of TX_CLK, TXE, and TXD[0:3] signals for sending data and RX_CLK, CRS, RXDV, RXD[0:3], and COL signals for receiving data.

When sending data from the W3150, TXE and TXD[0:3] are output in synchronization with the falling edges of TX_CLK input from the Physical Layer Device because Physical Layer Devices generally recognize the rising edges of TX_CLK.

When receiving data, in general, the Physical Layer Devices output CRS, RXDV, RXD[0:3], and COL signals in synchronization with the falling edges of RX_CLK, so the W3100A recognizes the signals at the rising edges of RX_CLK.

7. Electrical Specification

7.1. Absolute Maximum Ratings

Symbol	Parameter	Rating	Unit
V_{DD}	DC Supply voltage	-0.3 to 3.6	V
V_{IN}	DC input voltage	-0.3 to 5.5 (5V tolerant)	V
I_{IN}	DC input current	± 15	mA
T_{OP}	Operating temperature	0 to 80	$^{\circ}C$
T_{STG}	Storage temperature	-55 to 125	$^{\circ}C$

***COMMENT:** Stressing the device beyond the "Absolute Maximum Ratings" may cause permanent damage.

7.2. DC Characteristics

Symbol	Parameter	Test Condition	Min	Typ	Max	Unit
V_{DD}	DC Supply voltage	Junction temperature is from -55C to 125C	3.0		3.6	V
V_{IH}	High level input voltage		2.0		$V_{DD} + 0.3$	V
V_{IL}	Low level input voltage		- 0.3		$0.3 * V_{DD}$	V
V_{OH}	High level output voltage	$V_{DD} = 3.0,$ $V_I = V_{IH}$	$I_{OH} = -100 \text{ A}$	2.9		V
			$I_{OH} = -1 \text{ mA}$	2.4		V
			$I_{OH} = -2 \text{ mA}$	1.9		V
V_{OL}	Low level output voltage	$V_{DD} = 3.0,$ $V_I = V_{IL}$	$I_{OL} = 100 \text{ A}$		0.2	V
			$I_{OL} = 1 \text{ mA}$		0.4	V
			$I_{OL} = 2 \text{ mA}$		0.6	V
I_I	Input Current	$V_{DD} = 3.6, V_I = V_{DD} \text{ or GND}$			± 15	A

7.3.AC Characteristics

7.3.1. Reset Timing

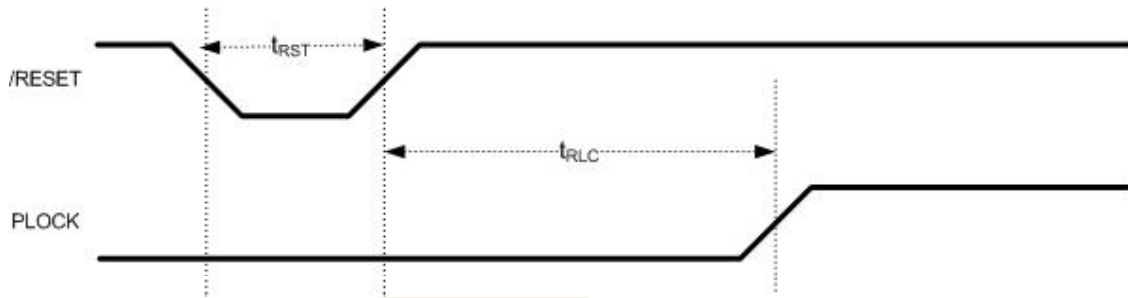

Symbol	Parameter	Min	Max
t_{RST}	Reset Cycle Time	96 ns	-
t_{RLC}	/RESET to PLOCK Output	-	125 μ s

7.3.2. Register/Memory READ Timing

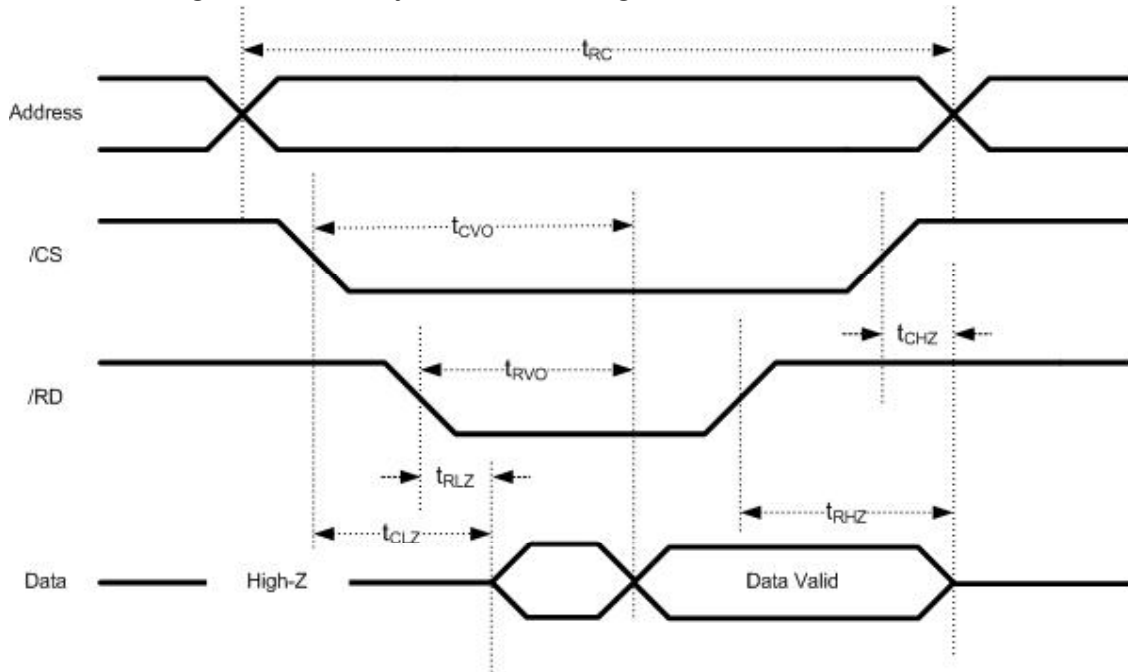

Symbol	Parameter	Min	Max
t_{RC}	Read Cycle Time	96 ns	-
t_{CVO}	/CS to Valid Output	-	96 ns
t_{RVO}	/RD to Valid Output	-	96 ns
t_{CLZ}	/CS to Low-Z Output	0 ns	-
t_{RLZ}	/RD to Low-Z Output	0 ns	-
t_{CHZ}	/CS to High-Z Output	-	1 ns
t_{RHZ}	/RD to High-Z Output	-	1 ns

7.3.3. Register/Memory WRITE Timing

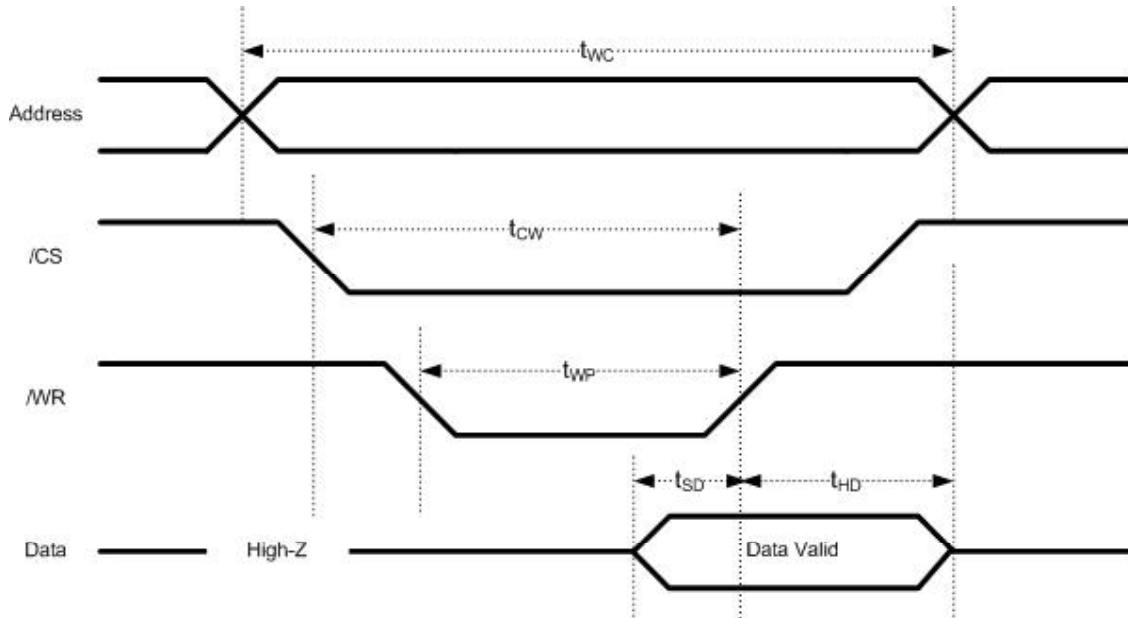

Symbol	Parameter	Min	Max
t_{WC}	Write Cycle Time	72 ns	-
t_{CW}	\overline{CS} to Write End	64 ns	-
t_{WP}	\overline{WR} Pulse width	64 ns	-
t_{SD}	Data Setup to Write End	8 ns	-
t_{HD}	Data Hold from Write End	8 ns	-

7.3.4. MII(Media Independent Interface) Timing

■ MII Tx TIMING

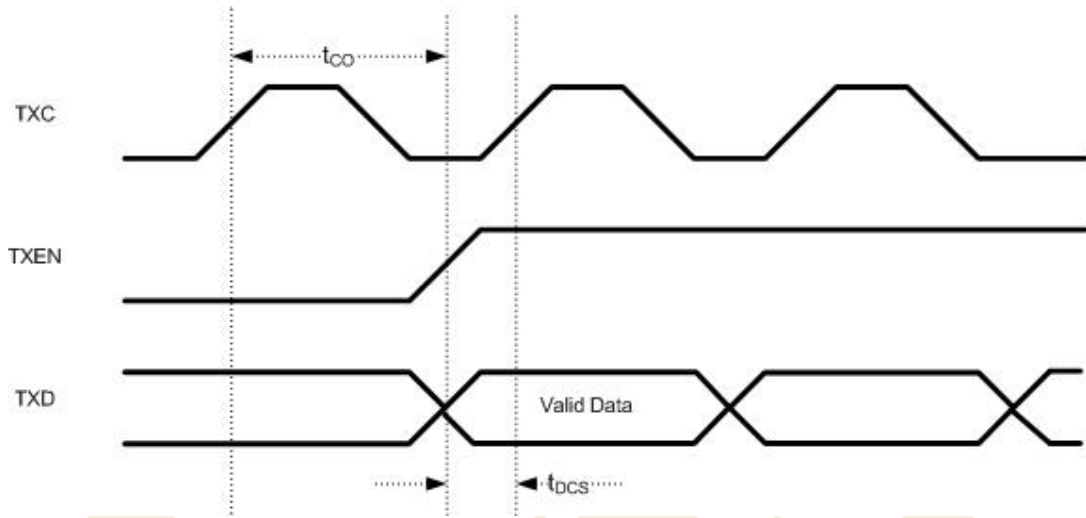

Symbol	Parameter	Notes	Min	Typ	Max
t_{CO}	TX_CLK to TXD, TX_EN	10 Mbps	202 ns	-	205 ns
t_{DCS}	TXD, TX_EN setup time to TX_CLK	10 Mbps	195 ns	-	198 ns
t_{CO}	TX_CLK to TXD, TX_EN	100 Mbps	22 ns	-	25 ns
t_{DCS}	TXD, TX_EN setup time to TX_CLK	100 Mbps	15 ns	-	18 ns

■ MII Rx TIMING

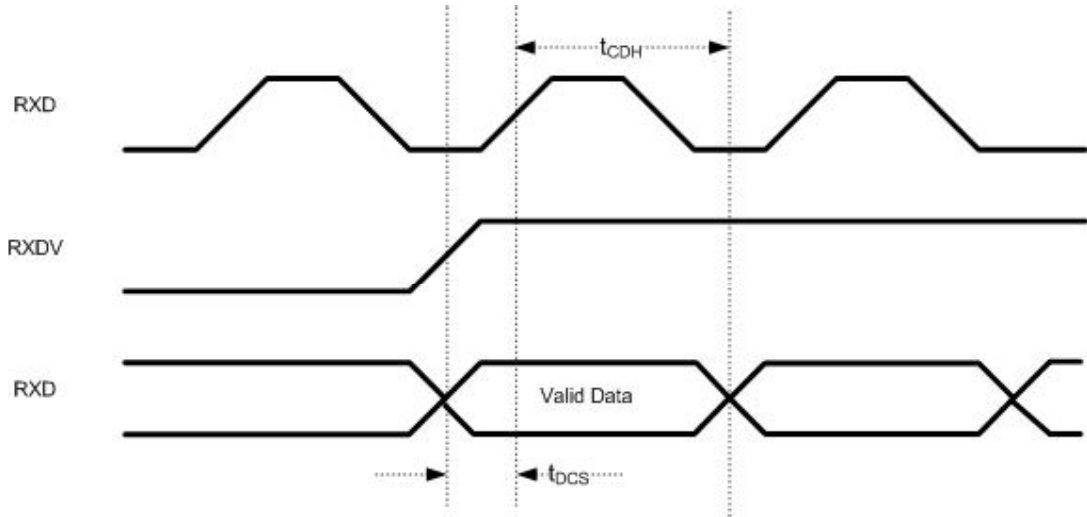

Symbol	Parameter	Notes	Min	Typ	Max
t_{DCS}	Valid Data to RX_CLK (setup)	10 Mbps	5 ns	-	-
t_{CDH}	RX_CLK to Valid Data (hold)	10 Mbps	5 ns	-	-
t_{DCS}	Valid Data to RX_CLK (setup)	100 Mbps	5 ns	-	-
t_{CDH}	RX_CLK to Valid Data (hold)	100 Mbps	5 ns	-	-

8. IR Reflow Temperature Profile (Lead-Free)

- Moisture Sensitivity Level at 260°C IR Condition: 2.
- Dry Bag Required: Yes
- 1 year out of bag time at max 30°C/60%RH.

Max. Temperature 260°C	
Ramp up rate	< 3°C/second
Pre-heat temperature at 175°C(±25°C)	77-95 seconds
Temperature above 217°C	96-107 seconds
Time within 5°C of actual peak temperature	17-25 seconds
Peak temperature range	258-260°C
Ramp-down rate	< 6°C/second

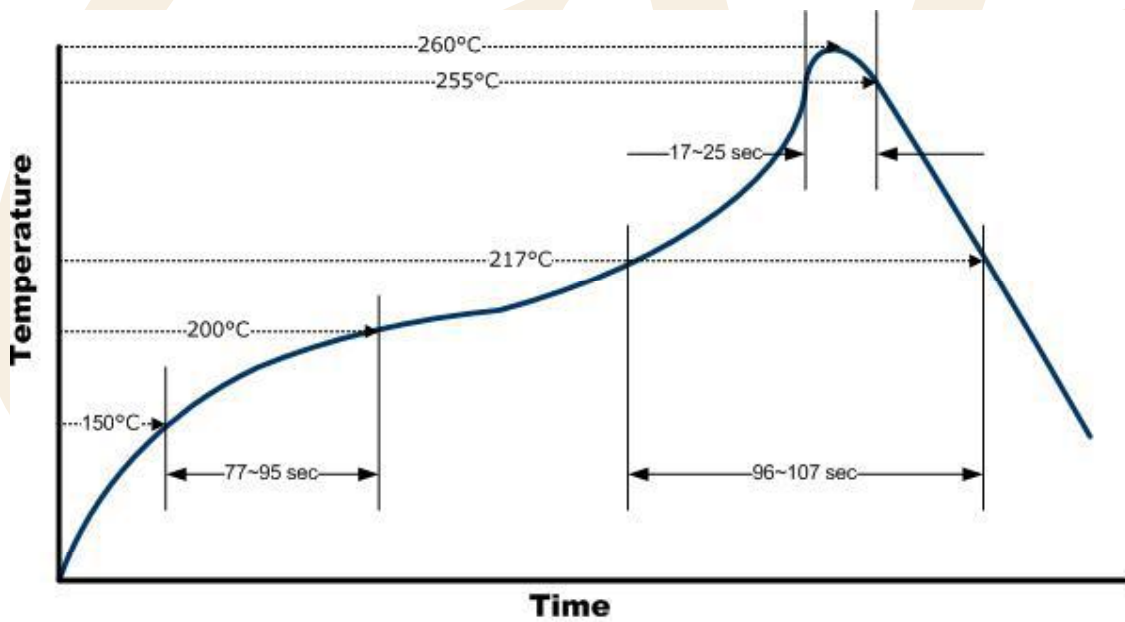

9. Package Description

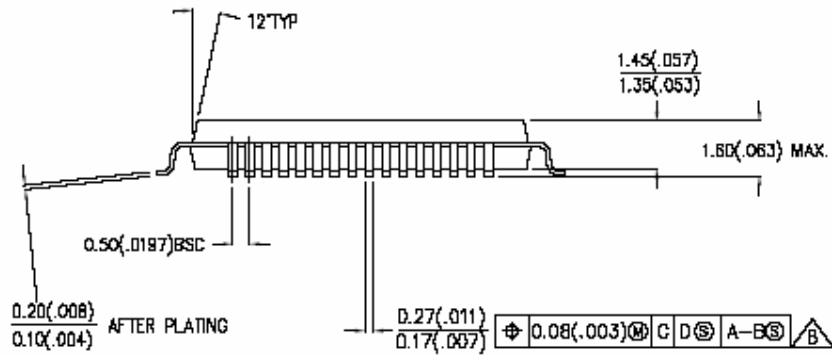
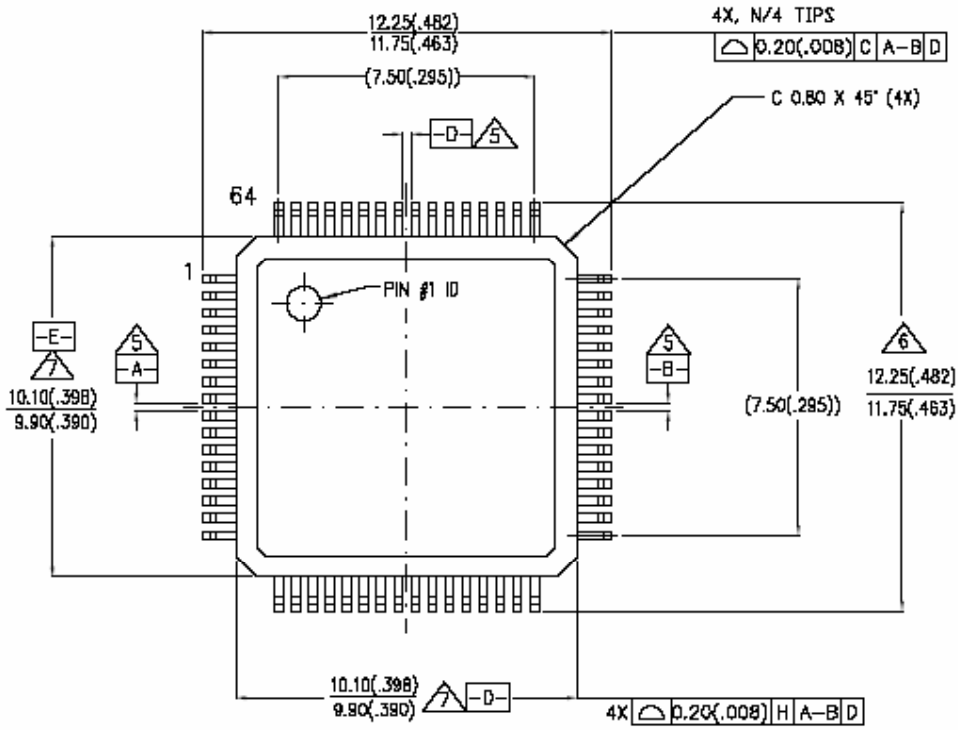

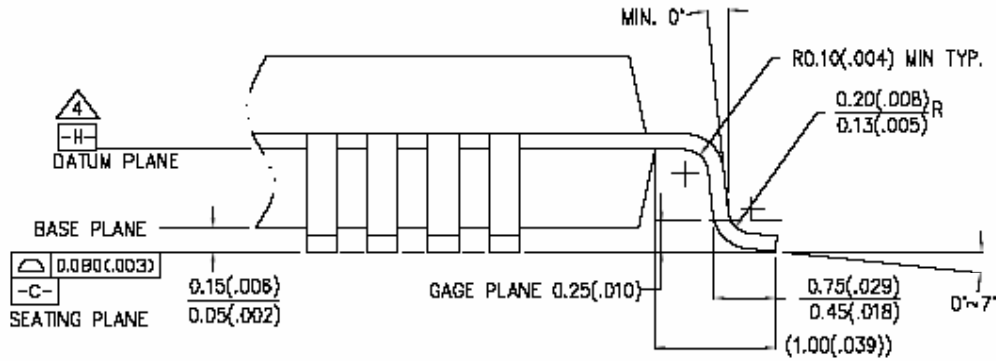

NOTES :

1. PACKAGE DIMENSIONS CONFORM TO JEDEC REGISTRATION MO - 138 - BCD.
2. CONTROLLING DIMENSIONS : MILLIMETERS. INCH ARE SHOWN IN PARENTHESSES.
3. DIMENSIONS AND TOLERANCING PER ANSI Y 14.5-1982.
4. DATUM PLANE "H" IS LOCATED AT MOLD PARTING LINE AND IS COINCIDENT WITH THE LEAD EXITS THE PLASTIC BODY AT BOTTOM OF THE PARTING LINE.
5. DATUMS "A-B" AND "D" TO BE DETERMINED AT DATUM PLANE "H".
6. TO BE DETERMINED AT THE SEATING PLANE "C"
7. THESE DIMENSIONS TO BE DETERMINED AT DATUM PLANE "H". DIMENSIONS D AND E DO NOT INCLUDE MOLD PROTRUSION. ALLOWABLE PROTRUSION IS 0.25MM(.010") PER SIDE.
8. LEAD WIDTH DOES NOT INCLUDE DAMBAR PROTRUSION. ALLOWABLE DAMBAR PROTRUSION SHALL BE 0.08 MM/0.003" TOTAL IN EXCESS OF THIS DIMENSIONS AT MAXIMUM MATERIAL CONDITION.