

# SHINDENGEN

## Switching Power Transistor

FX Series

**2SC4059**  
**(T15W45FX)**

**15A NPN**

### OUTLINE DIMENSIONS

Case : MTO-3P

Unit : mm

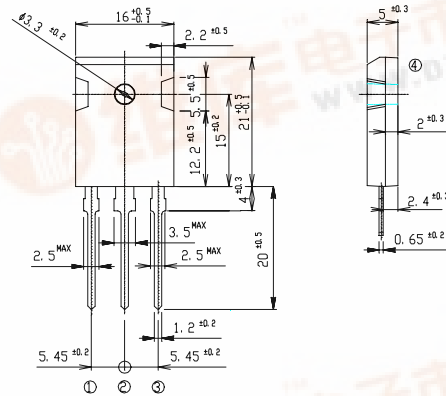

- ⊙: B
- ⊙: C
- ⊙: E
- ⊙: C

### RATINGS

● Absolute Maximum Ratings

Item	Symbol	Conditions	Ratings	Unit
Storage Temperature	T <sub>stg</sub>		-55~150	°C
Junction Temperature	T <sub>j</sub>		150	°C
Collector to Base Voltage	V <sub>CB0</sub>		600	V
Collector to Emitter Voltage	V <sub>CEO</sub>		450	V
	V <sub>CEX</sub>	V <sub>EB</sub> = 5V	600	
Emitter to Base Voltage	V <sub>EBO</sub>		7	V
Collector Current DC	I <sub>C</sub>		15	A
Collector Current Peak	I <sub>CP</sub>		30	
Base Current DC	I <sub>B</sub>		6	A
Base Current Peak	I <sub>BP</sub>		12	
Total Transistor Dissipation	P <sub>T</sub>	T <sub>c</sub> = 25°C	130	W
Mounting Torque	TOR		0.8	N·m

● Electrical Characteristics (T<sub>c</sub>=25°C)

Item	Symbol	Conditions	Ratings	Unit
Collector to Emitter Sustaining Voltage	V <sub>CEO(sus)</sub>	I <sub>C</sub> = 0.2A	Min 450	V
Collector Cutoff Current	I <sub>CBO</sub>	At rated Voltage	Max 0.1	mA
	I <sub>CEO</sub>		Max 0.1	
Emitter Cutoff Current	I <sub>EBO</sub>	At rated Voltage	Max 0.1	mA
DC Current Gain	h <sub>FE</sub>	V <sub>CE</sub> = 5V, I <sub>C</sub> = 7.5A	Min 10	
	h <sub>FEL</sub>	V <sub>CE</sub> = 5V, I <sub>C</sub> = 1mA	Min 5	
Collector to Emitter Saturation Voltage	V <sub>CE(sat)</sub>	I <sub>C</sub> = 7.5A	Max 1.0	V
Base to Emitter Saturation Voltage	V <sub>BE(sat)</sub>	I <sub>B</sub> = 1.5A	Max 1.5	V
Thermal Resistance	θ <sub>jc</sub>	Junction to case	Max 0.96	°C/W
Transition Frequency	f <sub>T</sub>	V <sub>CE</sub> = 10V, I <sub>C</sub> = 1.5A	STD 20	MHz
Turn on Time	ton	I <sub>C</sub> = 7.5A	Max 0.5	μs
Storage Time	ts	I <sub>B1</sub> = 1.5A, I <sub>B2</sub> = 3A	Max 2.0	
Fall Time	tf	R <sub>L</sub> = 20Ω, V <sub>BB2</sub> = 4V	Max 0.2	

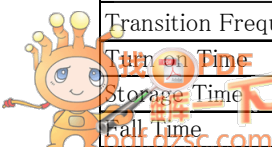

# 2SC4059

$h_{FE} - I_C$

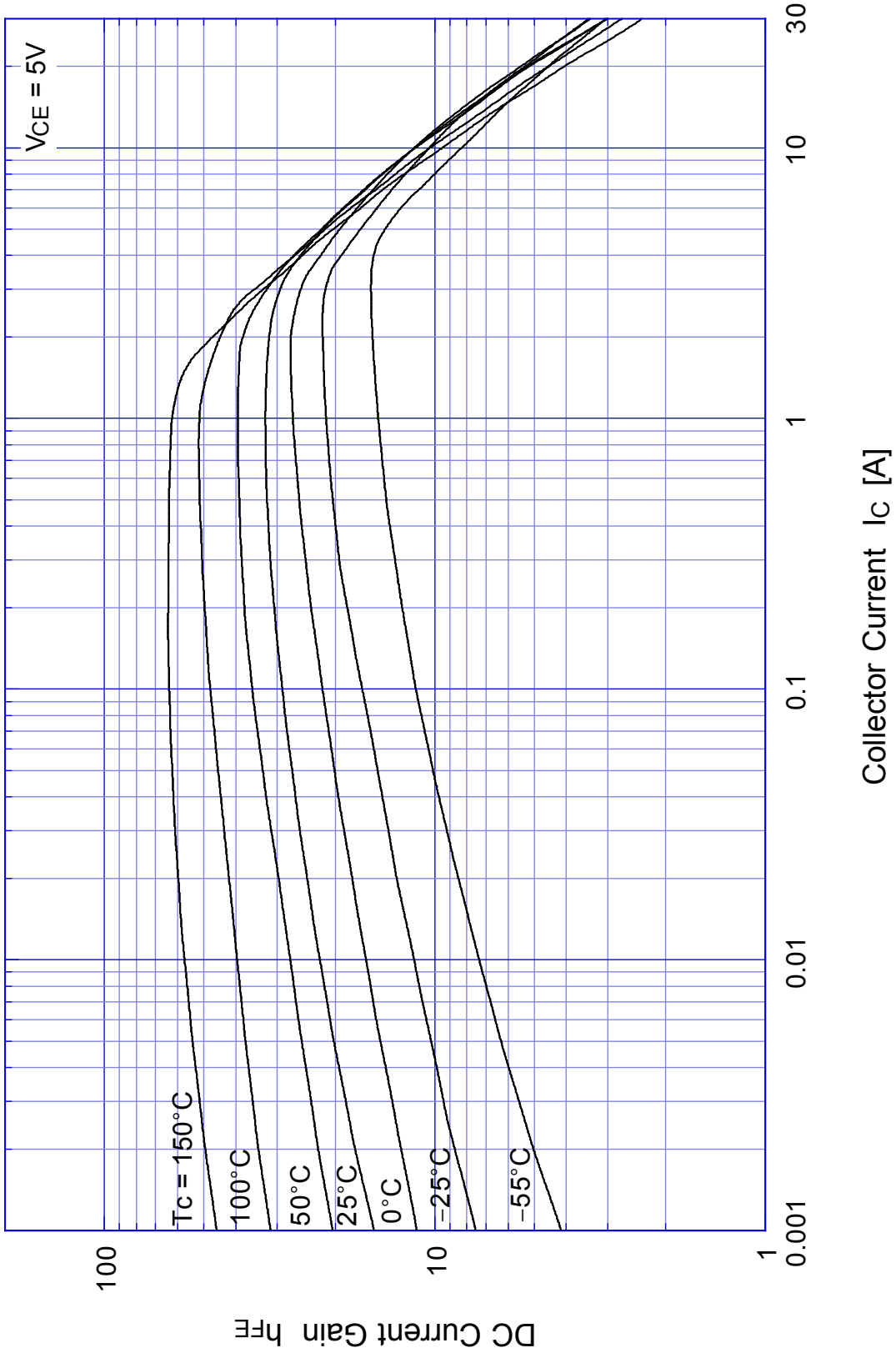

# 2SC4059 Saturation Voltage

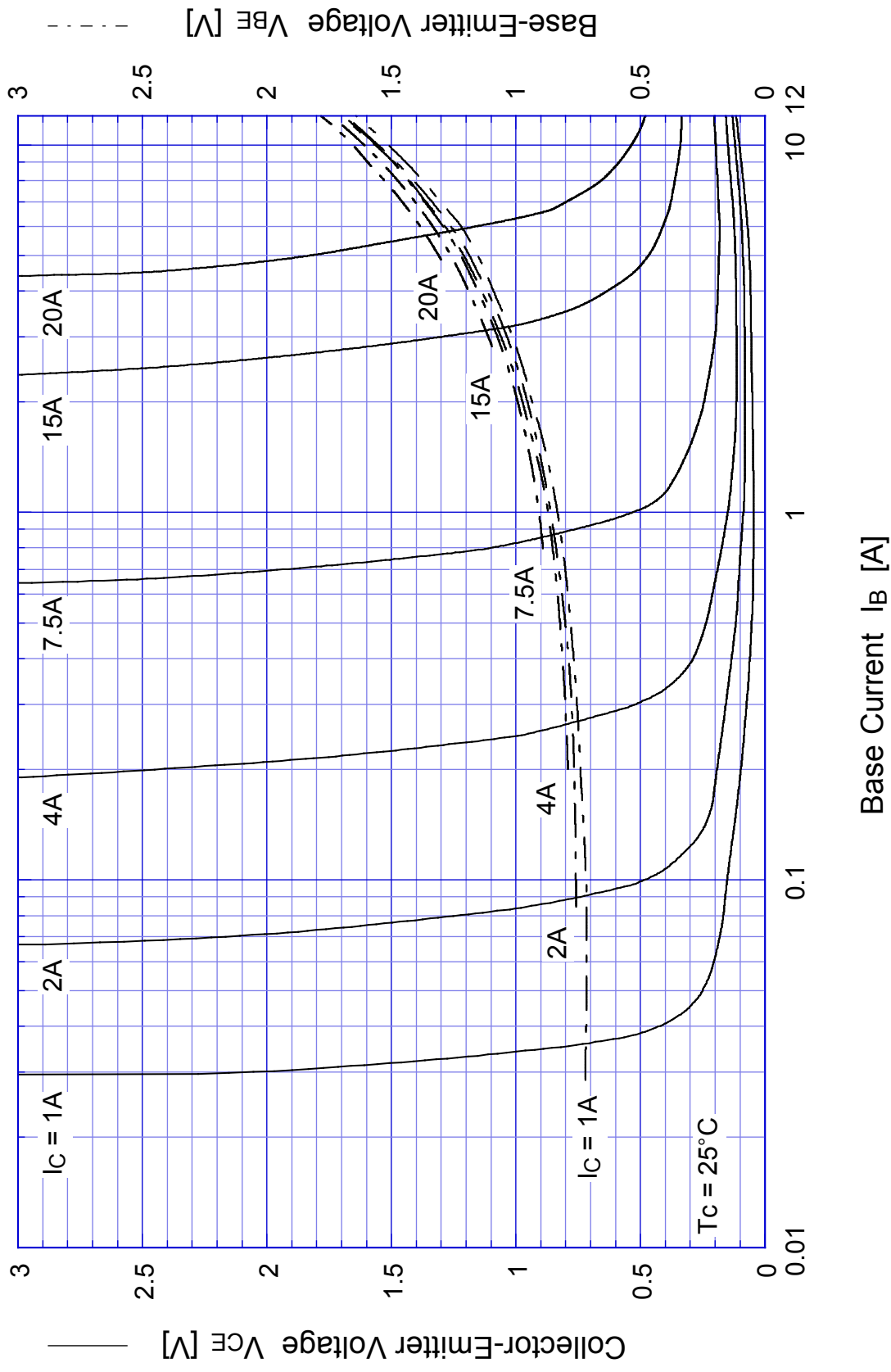

# 2SC4059

## Switching Time - $I_C$

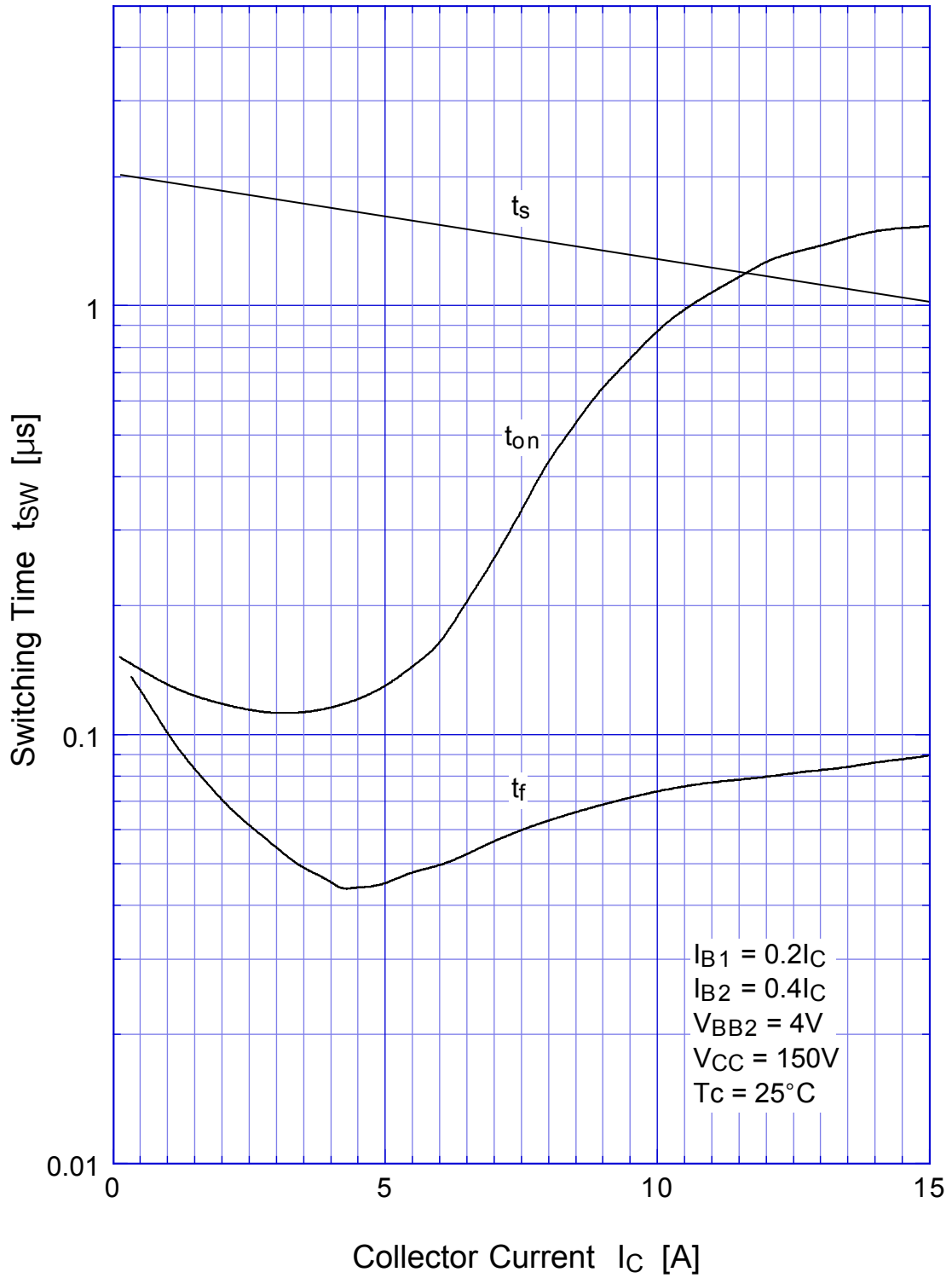

## 2SC4059 Switching Time - $V_{CC}$

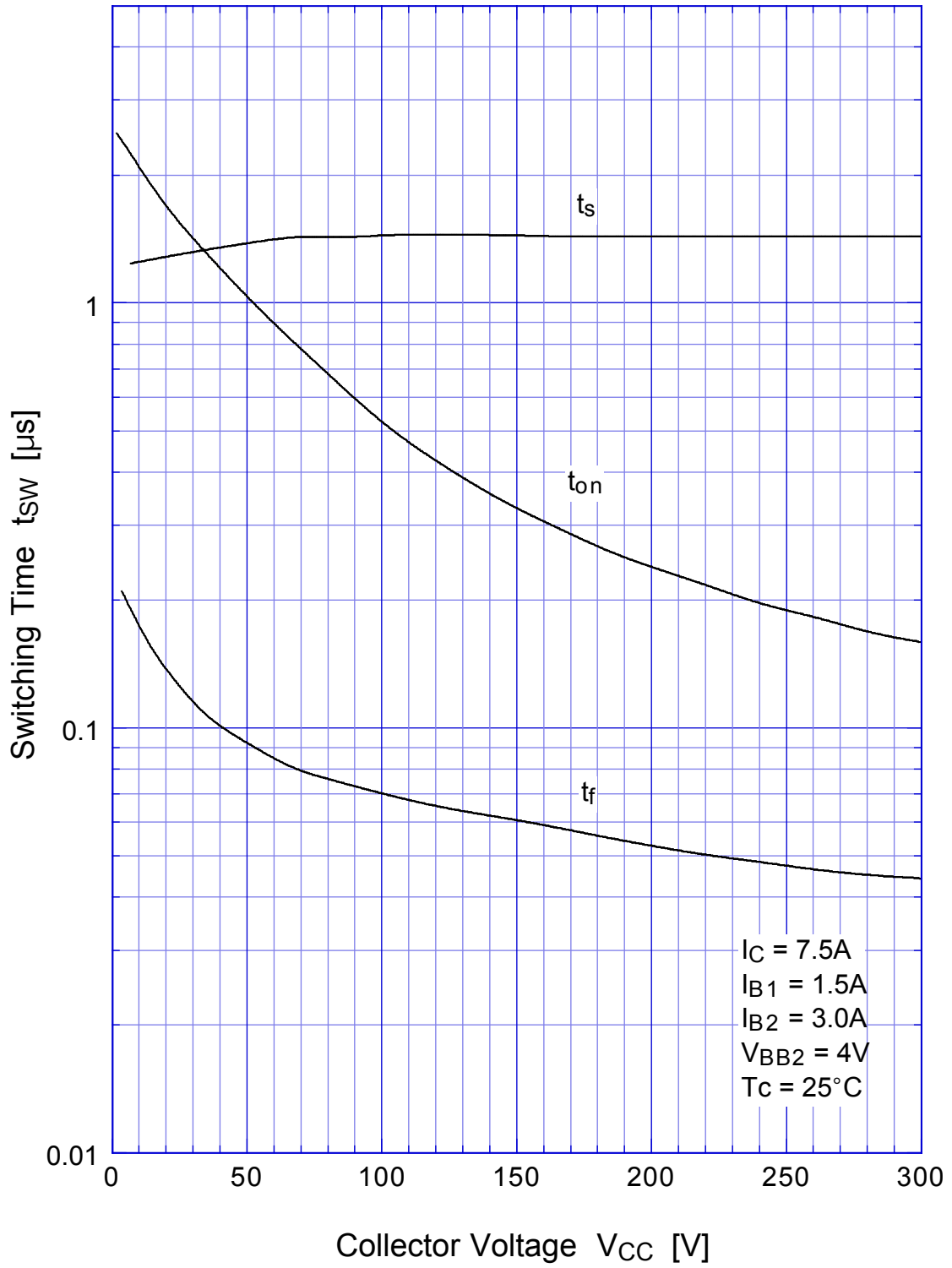

# 2SC4059

## Switching Time - Tc

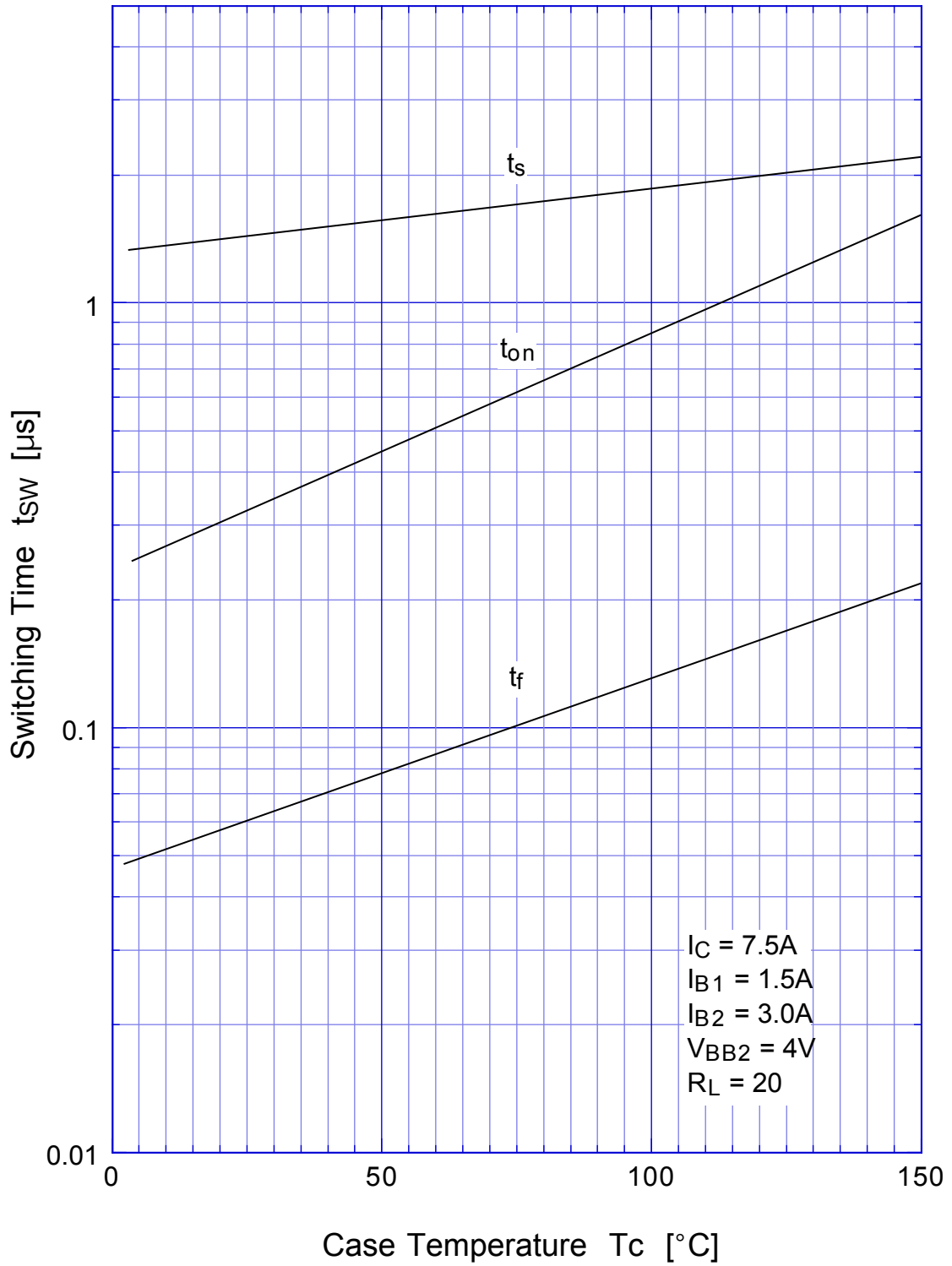

## 2SC4059 L-Load Switching Time - $I_C$

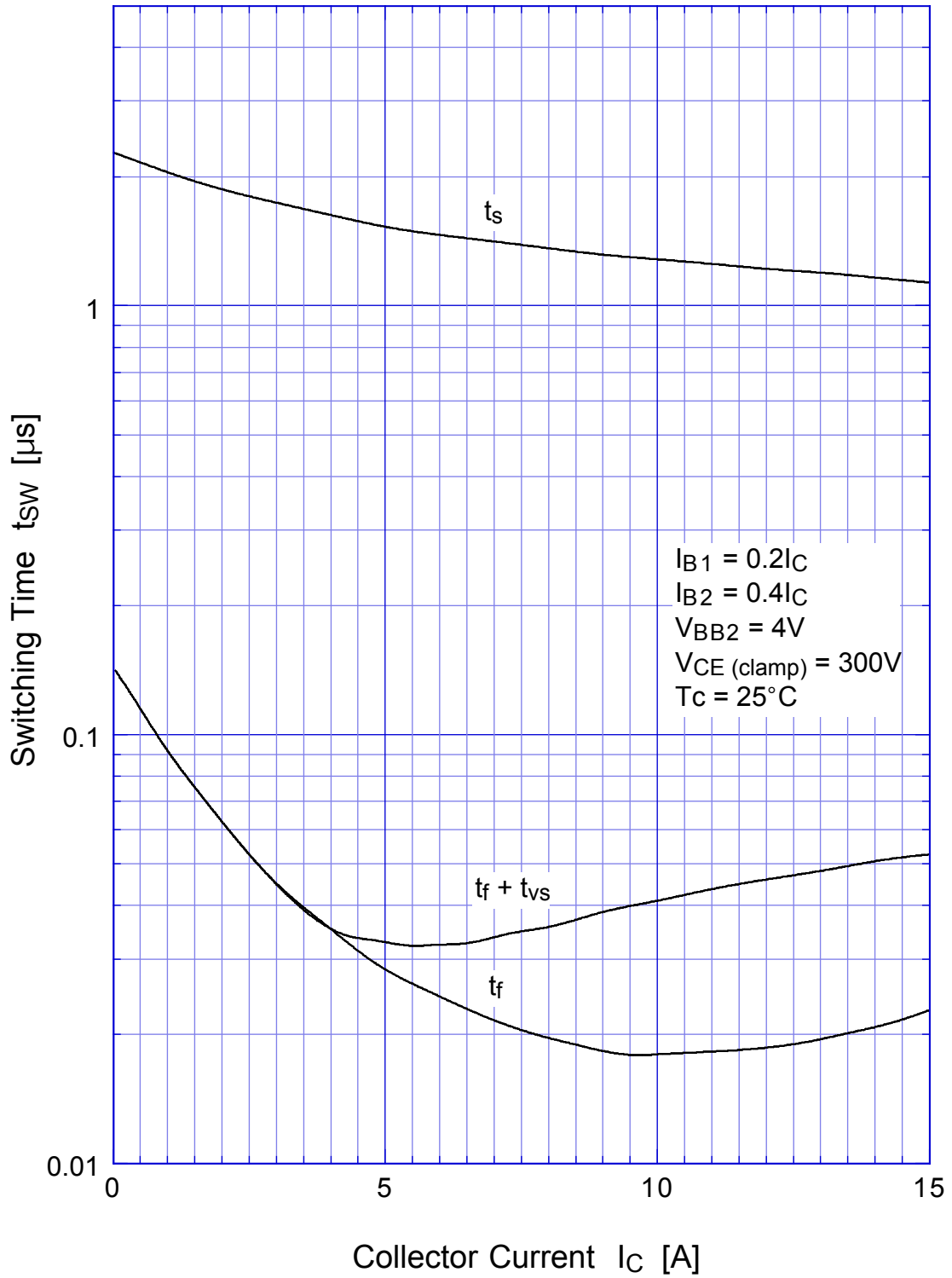

## 2SC4059 L-Load Switching Time - $I_C$ (At High Temperature)

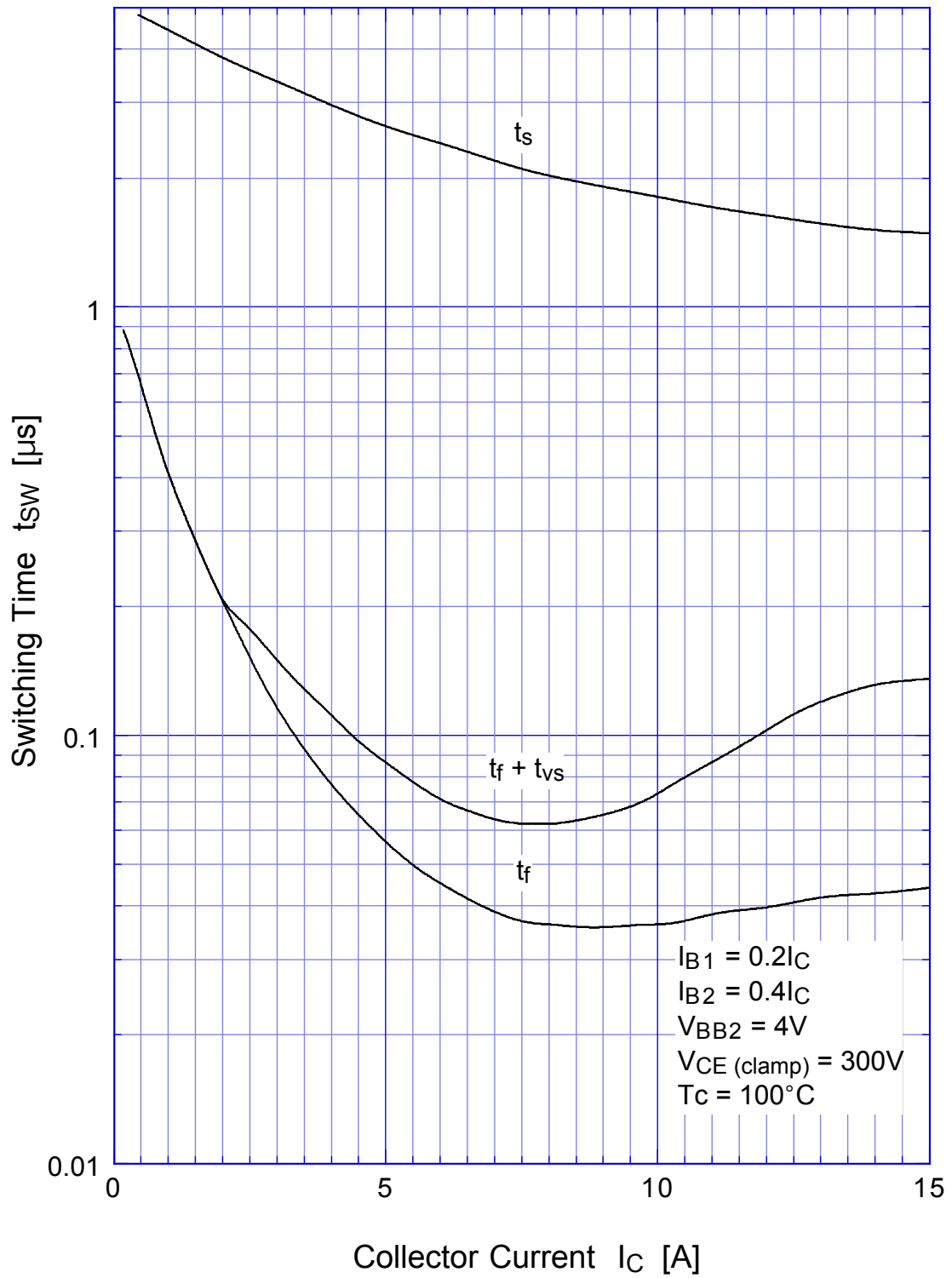



# 2SC4059 Transient Thermal Impedance

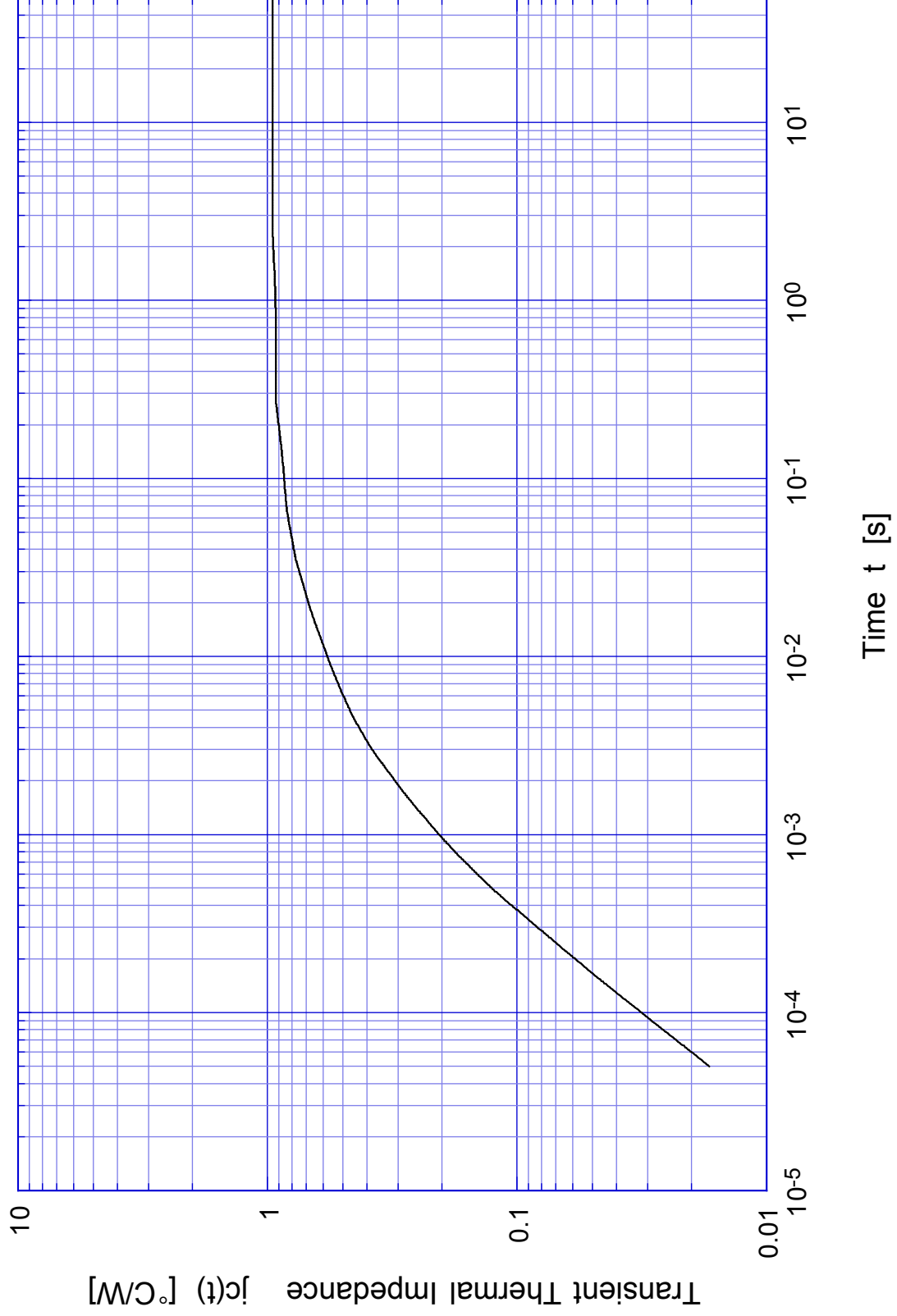

# 2SC4059

## Forward Bias SOA

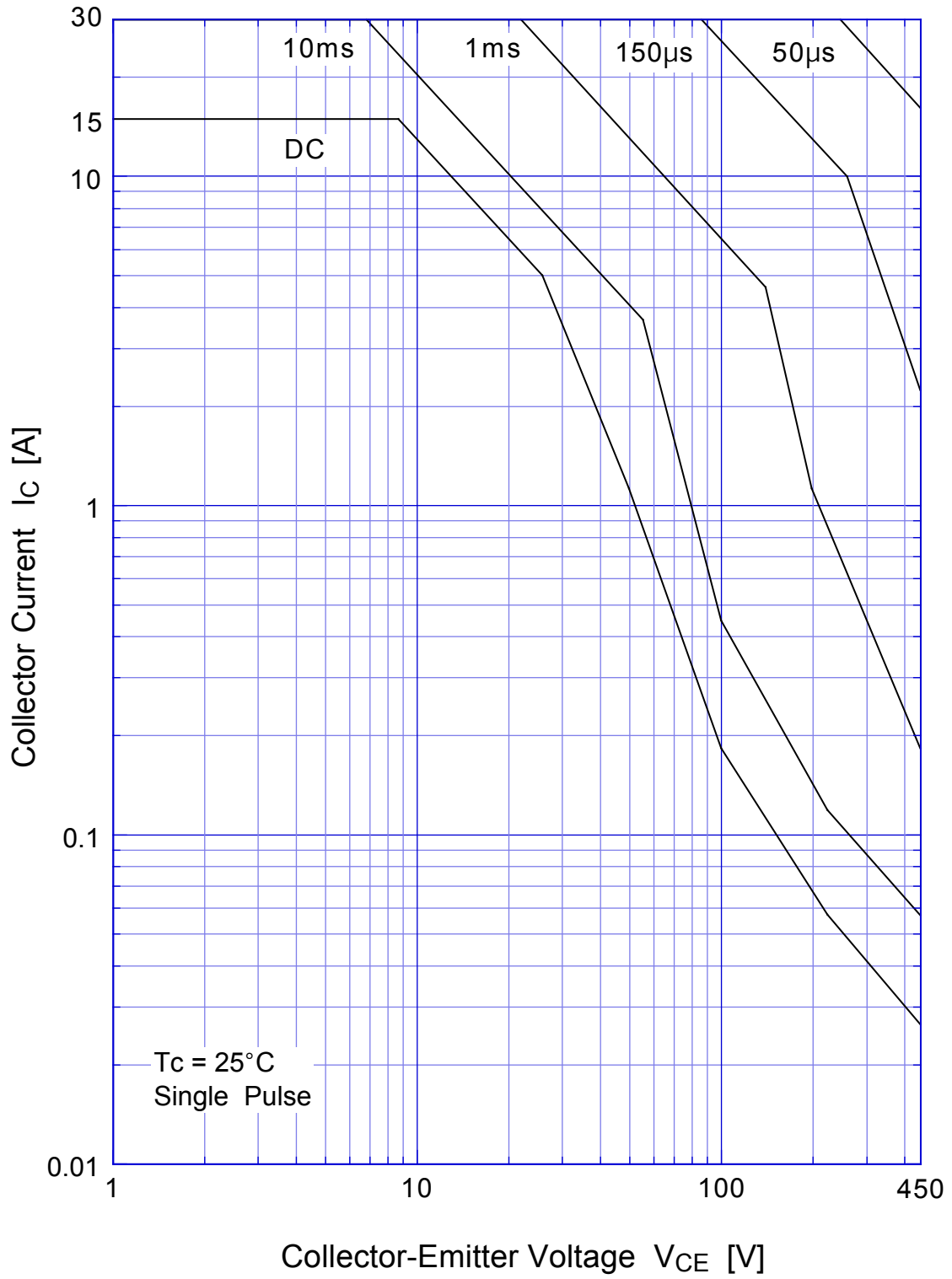

## 2SC4059 Collector Current Derating

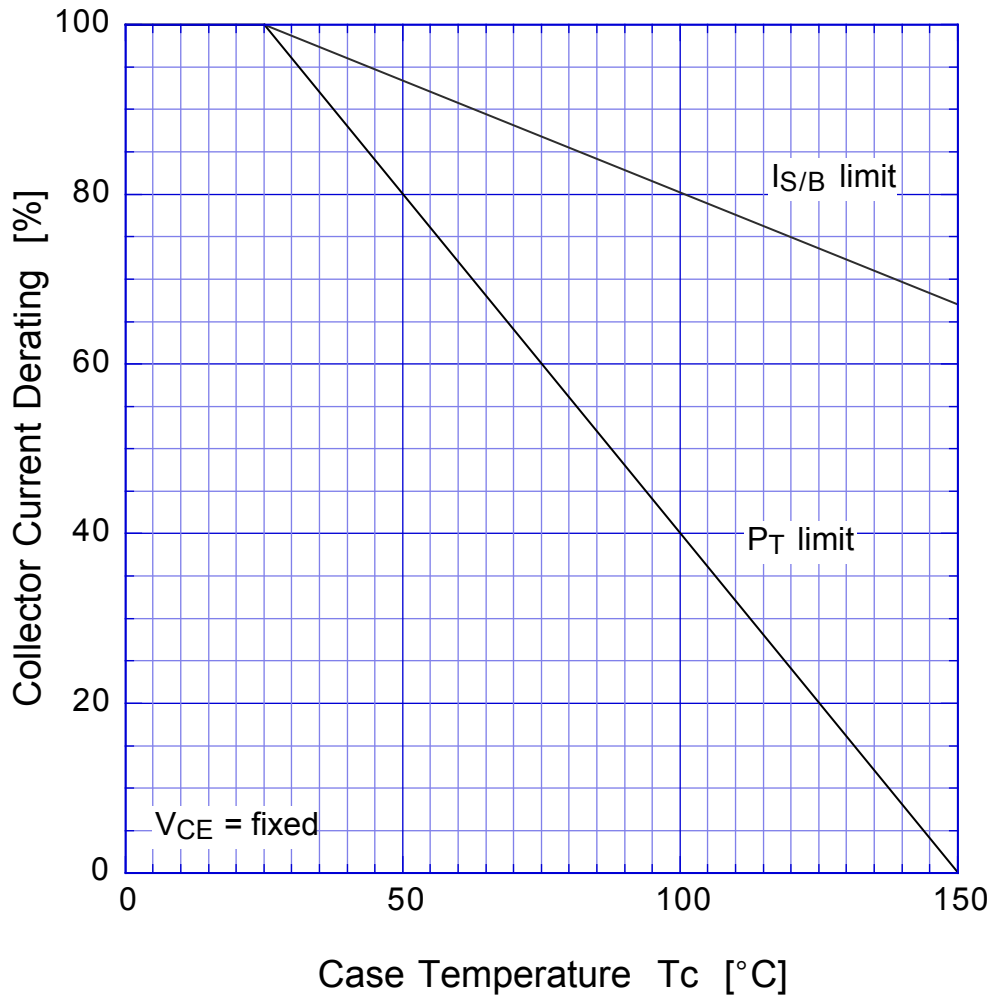

2SC4059

Reverse Bias SOA

