

SMD Type Diodes

Schottky Barrier Diodes

MMBD101

Features

- Low Noise Figure-6.0dB Typ@1.0GHz
- Very Low Capacitance-Less Than 1.0pF@zero Volts
- High Forward Conductance-0.5volts(typ)@I_F=10mA

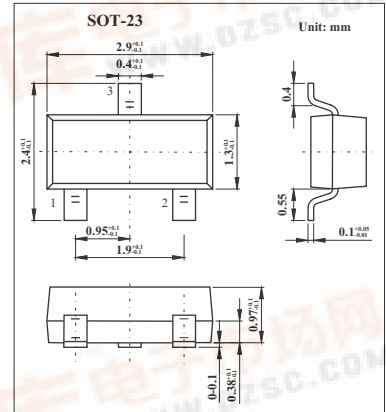

Absolute Maximum Ratings Ta = 25 °C

Parameter	Symbol	Value	Unit
Reverse voltage	V _R	7.0	V
Forward Power Dissipation @ T _A = 25 °C	pF	280	mW
Derate above 25 °C		2.2	mW/°C
Junction temperature	T _j	150	°C
Storage temperature range	T _{stg}	-55 to +150	°C

Electrical Characteristics Ta = 25 °C

Parameter	Symbol	Conditions	Min	Typ	Max	Unit
Reverse Breakdown Voltage	V _{(BR)R}	I _R = 10 μ A	7.0	10		V
Diode Capacitance	C _T	V _R = 0, f = 1.0MHz, Note1		0.88	1.0	pF
Forward Voltage	V _F	I _F = 10 mA		0.5	0.6	V
Reverse Leakage	I _R	V _R = 3.0 V		0.02	0.25	μ A

Marking

Marking	4M
---------	----