

INCHANGE Semiconductor

Product Specification

Silicon NPN Power Transistor

2SD1545

DESCRIPTION

- High Breakdown Voltage-
: $V_{CBO}=1500V$ (Min)
- High Switching Speed
- Low Saturation Voltage

APPLICATIONS

- Color TV horizontal output applications
- Switching regulator output applications

ABSOLUTE MAXIMUM RATINGS($T_a=25^{\circ}C$)

SYMBOL	PARAMETER	VALUE	UNIT
V_{CBO}	Collector-Base Voltage	1500	V
V_{CEO}	Collector-Emitter Voltage	600	V
V_{EBO}	Emitter-Base Voltage	5	V
I_C	Collector Current- Continuous	5	A
I_B	Base Current- Continuous	2.5	A
P_C	Collector Power Dissipation @ $T_C=25^{\circ}C$	50	W
T_J	Junction Temperature	150	$^{\circ}C$
T_{stg}	Storage Temperature Range	-55~150	$^{\circ}C$

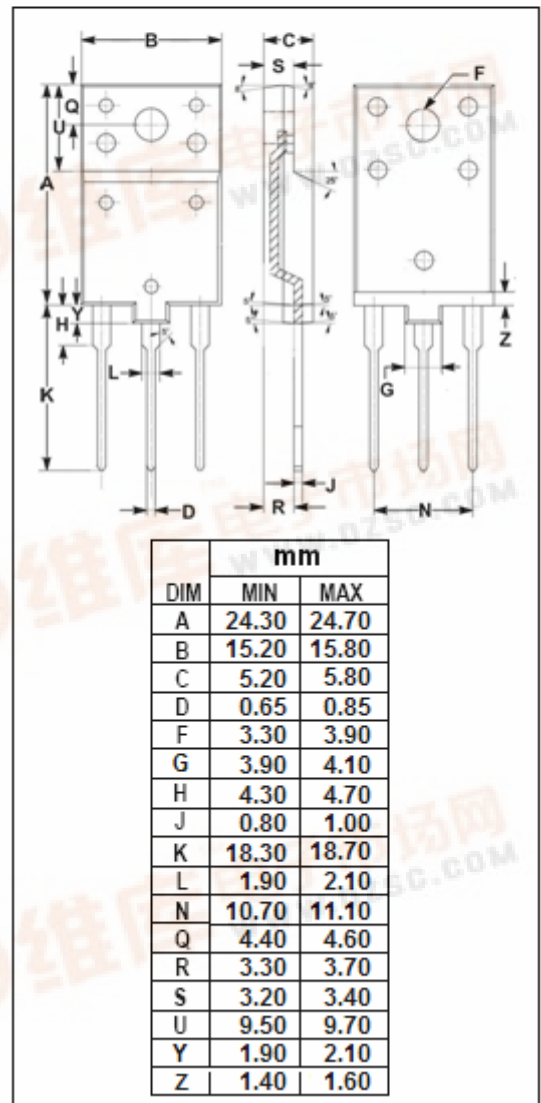
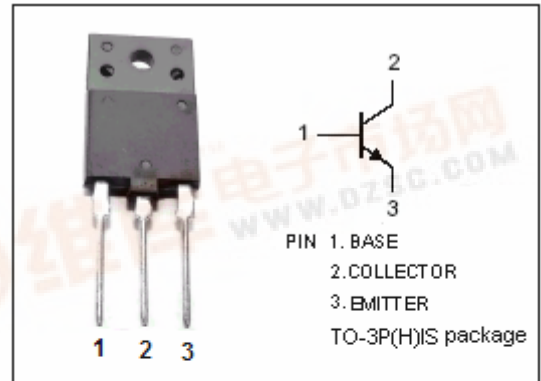

Silicon NPN Power Transistor

2SD1545

ELECTRICAL CHARACTERISTICS

 $T_C=25^\circ\text{C}$ unless otherwise specified

SYMBOL	PARAMETER	CONDITIONS	MIN	TYP.	MAX	UNIT
$V_{CE(sat)}$	Collector-Emitter Saturation Voltage	$I_C= 4.0A; I_B= 0.8A$			5.0	V
$V_{BE(sat)}$	Base-Emitter Saturation Voltage	$I_C= 4.0A; I_B= 0.8A$			1.5	V
I_{CBO}	Collector Cutoff Current	$V_{CB}= 500V ; I_E= 0$			10	μA
I_{EBO}	Emitter Cutoff Current	$V_{EB}= 5V ; I_C= 0$			1.0	mA
h_{FE}	DC Current Gain	$I_C= 1A ; V_{CE}= 5V$	8			
f_T	Current-Gain—Bandwidth Product	$I_C= 0.1A ; V_{CE}= 10V$		3		MHz
C_{OB}	Output Capacitance	$I_E= 0 ; V_{CB}= 10V; f_{test}= 1.0MHz$		165		pF
t_f	Fall Time	$I_{CP}= 4A , I_{B1(end)}= 0.8A$		0.5	1.0	μs

Silicon NPN Power Transistor

2SD1545

