

SavantIC Semiconductor

Product Specification

Silicon PNP Darlington Power Transistors

2SB1624

DESCRIPTION

- With TO-3PN package
- Complement to type 2SD2493

APPLICATIONS

- Audio ,regulator and general purpose

PINNING

| PIN | DESCRIPTION |
|-----|--------------------------------------|
| 1 | Base |
| 2 | Collector;connected to mounting base |
| 3 | Emitter |

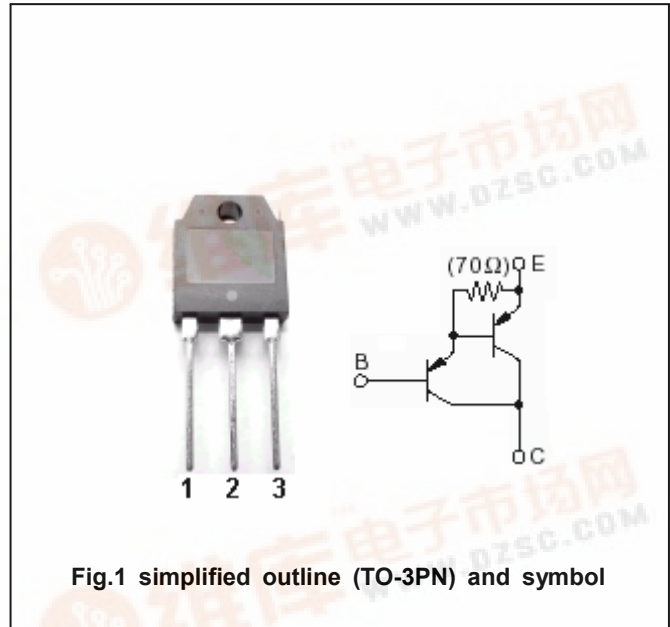

Fig.1 simplified outline (TO-3PN) and symbol

Absolute maximum ratings(Ta=□)

| SYMBOL | PARAMETER | CONDITIONS | VALUE | UNIT |
|------------------|-----------------------------|---------------------|---------|------|
| V _{CBO} | Collector-base voltage | Open emitter | -110 | V |
| V _{CEO} | Collector-emitter voltage | Open base | -110 | V |
| V _{EBO} | Emitter-base voltage | Open collector | -5 | V |
| I _C | Collector current | | -6 | A |
| I _B | Base current | | -1 | A |
| P _C | Collector power dissipation | T _C =25□ | 60 | W |
| T _j | Junction temperature | | 150 | □ |
| T _{stg} | Storage temperature | | -55~150 | □ |

Silicon PNP Darlington Power Transistors

2SB1624

CHARACTERISTICS

T_j=25°C unless otherwise specified

| SYMBOL | PARAMETER | CONDITIONS | MIN | TYP. | MAX | UNIT |
|----------------------|--------------------------------------|--|------|------|------|------|
| V _{(BR)CEO} | Collector-emitter breakdown voltage | I _C =-30mA ; I _B =0 | -110 | | | V |
| V _{CEsat} | Collector-emitter saturation voltage | I _C =-5A ; I _B =-5mA | | | -2.5 | V |
| V _{BEsat} | Base-emitter saturation voltage | I _C =-5A ; I _B =-5mA | | | -3.0 | V |
| I _{CBO} | Collector cut-off current | V _{CB} =-110V ; I _E =0 | | | -100 | μA |
| I _{EBO} | Emitter cut-off current | V _{EB} =-5V ; I _C =0 | | | -100 | μA |
| h _{FE} | DC current gain | I _C =-5A ; V _{CE} =-4V | 5000 | | | |
| C _{ob} | Output capacitance | I _E =0 ; V _{CB} =-10V ; f=1MHz | | 110 | | pF |
| f _T | Transition frequency | I _C =-0.5A ; V _{CE} =-12V | | 100 | | MHz |

Switching times

| | | | | | | |
|-----------------|--------------|---|--|-----|--|----|
| t _{on} | Turn-on time | I _C =-5A ; R _L =6Ω I _{B1} =- I _{B2} =-5mA V _{CC} =-30V | | 1.1 | | μs |
| t _s | Storage time | | | 3.2 | | μs |
| t _f | Fall time | | | 1.1 | | μs |

◆ h_{FE} Classifications

| O | P | Y |
|------------|------------|-------------|
| 5000-12000 | 6500-20000 | 15000-30000 |

Silicon PNP Darlington Power Transistors

2SB1624

PACKAGE OUTLINE

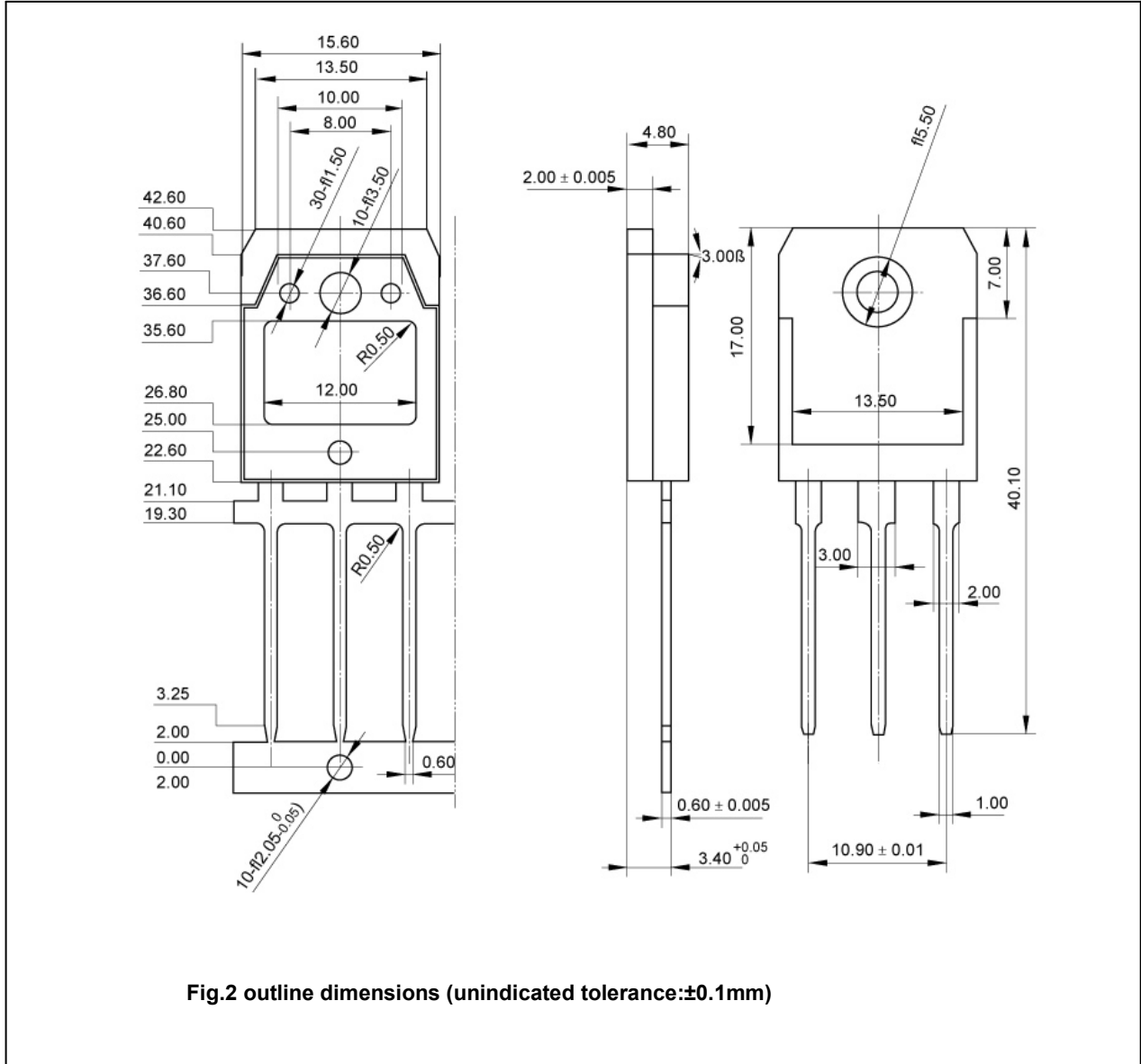

Fig.2 outline dimensions (unindicated tolerance:±0.1mm)