

Silicon NPN Power Transistors

2SD880

DESCRIPTION

- With TO-220C package
- Complement to type 2SB834
- Low collector saturation voltage

APPLICATIONS

- Designed for use in audio frequency power amplifier applications

PINNING

PIN	DESCRIPTION
1	Base
2	Collector;connected to mounting base
3	Emitter

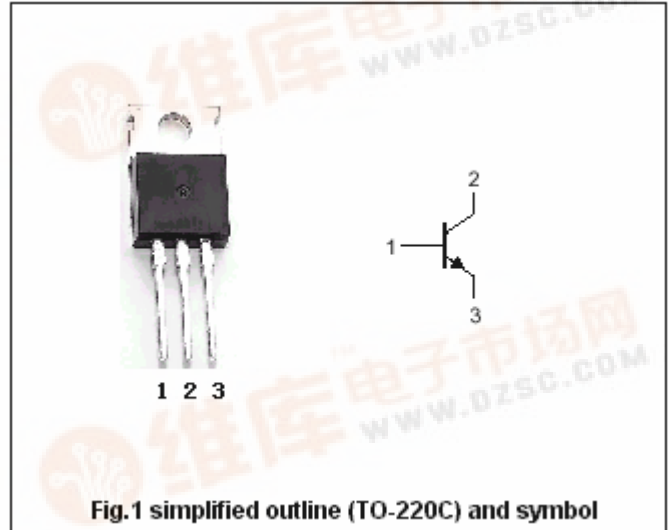

Absolute maximum ratings(Ta=25°C)

SYMBOL	PARAMETER	CONDITIONS	VALUE	UNIT
V _{CB0}	Collector-base voltage	Open emitter	60	V
V _{CEO}	Collector-emitter voltage	Open base	60	V
V _{EBO}	Emitter-base voltage	Open collector	7	V
I _C	Collector current		3	A
I _{CM}	Collector current-Peak		6	A
I _B	Base current		0.5	A
P _C	Collector dissipation	T _C =25°C	30	W
T _j	Junction temperature		150	°C
T _{stg}	Storage temperature		-50~150	°C

THERMAL CHARACTERISTICS

SYMBOL	CHARACTERISTICS	MAX	UNIT
Rθ _{jc}	Thermal resistance junction to case	4.16	°C/W

Silicon NPN Power Transistors

2SD880

CHARACTERISTICS

T_j=25°C unless otherwise specified

SYMBOL	PARAMETER	CONDITIONS	MIN	TYP.	MAX	UNIT
V _{(BR)CEO}	Collector-emitter breakdown voltage	I _C =50mA ; I _B =0	60			V
V _{(BR)EBO}	Emitter-base breakdown voltage	I _E =1mA ; I _C =0	7			V
V _{CEsat}	Collector-emitter saturation voltage	I _C =3A; I _B =0.3A			1.0	V
V _{BE}	Base-emitter on voltage	I _C =0.5A ; V _{CE} =5V			1.0	V
I _{CBO}	Collector cut-off current	V _{CB} =60V; I _E =0			100	μA
I _{EBO}	Emitter cut-off current	V _{EB} =7V; I _C =0			100	μA
h _{FE}	DC current gain	I _C =0.5A ; V _{CE} =5V	60		300	
f _T	Transition frequency	I _C =0.5A ; V _{CE} =5V; f=1MHz		3		MHz

Switching times

t _{on}	Turn-on time	I _C =10I _{B1} =-10I _{B2} =2A V _{CC} =30V PW=30μs			1.2	μs
t _s	Storage time				2.0	μs
t _f	Fall time				1.1	μs

◆ h_{FE} Classifications

O	Y	GR
60-120	100-200	150-300

Silicon NPN Power Transistors

2SD880

PACKAGE OUTLINE

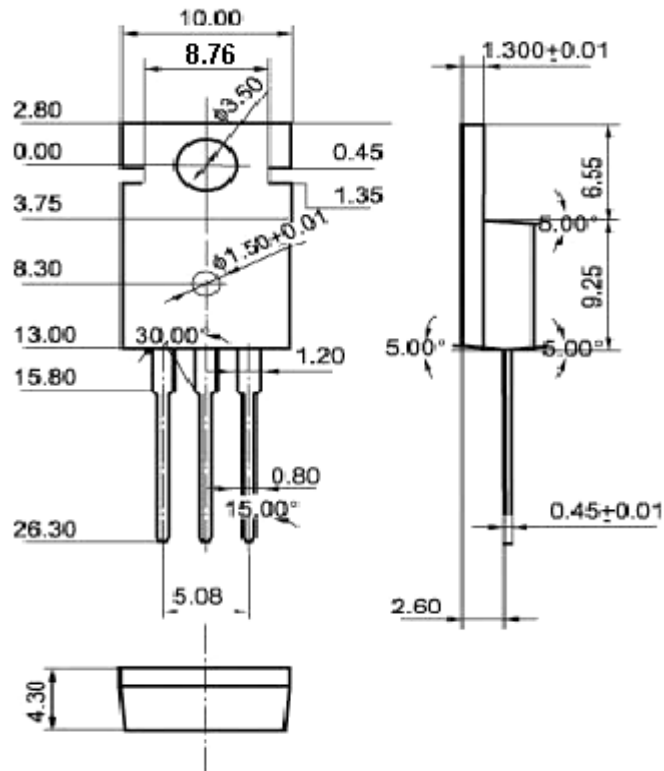

Fig.2 Outline dimensions (unindicated tolerance: ± 0.10 mm)