

SavantIC Semiconductor

Product Specification

Silicon NPN Power Transistors

BD433/435/437

DESCRIPTION

- With TO-126 package
- Complement to type BD434/436/438

APPLICATIONS

- For medium power linear and switching applications

PINNING

PIN	DESCRIPTION
1	Emitter
2	Collector;connected to mounting base
3	Base

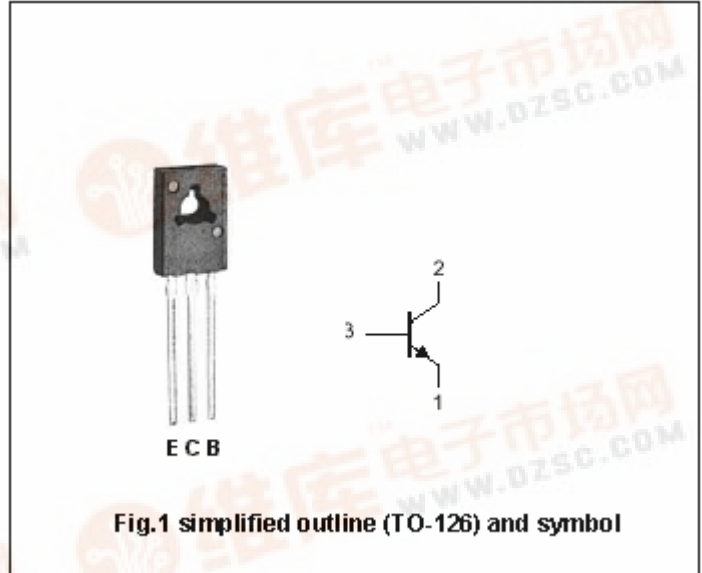

Absolute maximum ratings (Ta=25°C)

SYMBOL	PARAMETER	CONDITIONS	VALUE	UNIT
V _{CB0}	Collector-base voltage	BD433	22	V
		BD435	32	
		BD437	45	
V _{CEO}	Collector-emitter voltage	BD433	22	V
		BD435	32	
		BD437	45	
V _{EBO}	Emitter -base voltage	Open collector	5	V
I _C	Collector current (DC)		4	A
I _{CM}	Collector current-Peak		7	A
I _B	Base current		1	A
P _C	Collector power dissipation	T _C =25°C	36	W
T _j	Junction temperature		150	°C
T _{stg}	Storage temperature		-65~150	°C

Silicon NPN Power Transistors

BD433/435/437

CHARACTERISTICS

T_j=25°C unless otherwise specified

SYMBOL	PARAMETER		CONDITIONS	MIN	TYP.	MAX	UNIT
V _{CEsat}	Collector-emitter saturation voltage	BD433/435	I _C =2A; I _B =0.2A		0.2	0.5	V
		BD437				0.6	
V _{BE}	Base-emitter on voltage	BD433/435	I _C =2A; V _{CE} =1V			1.1	V
		BD437				1.2	
V _{CEO(SUS)}	Collector-emitter sustaining voltage	BD433	I _C =0.1A; I _B =0			22	V
		BD435				32	
		BD437				45	
I _{CES}	Collector cut-off current	BD433	V _{CB} =22V; I _E =0			100	μA
		BD435	V _{CB} =32V; I _E =0				
		BD437	V _{CB} =45V; I _E =0				
I _{CES}	Collector cut-off current	BD433	V _{CE} =22V; V _{BE} =0			100	μA
		BD435	V _{CE} =32V; V _{BE} =0				
		BD437	V _{CE} =45V; V _{BE} =0				
I _{EBO}	Emitter cut-off current		V _{EB} =5V; I _C =0			1	mA
h _{FE-1}	DC current gain	BD433/435	I _C =10mA; V _{CE} =5V			40	130
		BD437				30	
h _{FE-2}	DC current gain		I _C =0.5A; V _{CE} =1V			85	140
h _{FE-3}	DC current gain	BD433/435	I _C =2A; V _{CE} =1V			50	
		BD437				40	
f _T	Transition frequency		I _C =250mA; V _{CE} =1V			3	MHz

Silicon NPN Power Transistors

BD433/435/437

PACKAGE OUTLINE

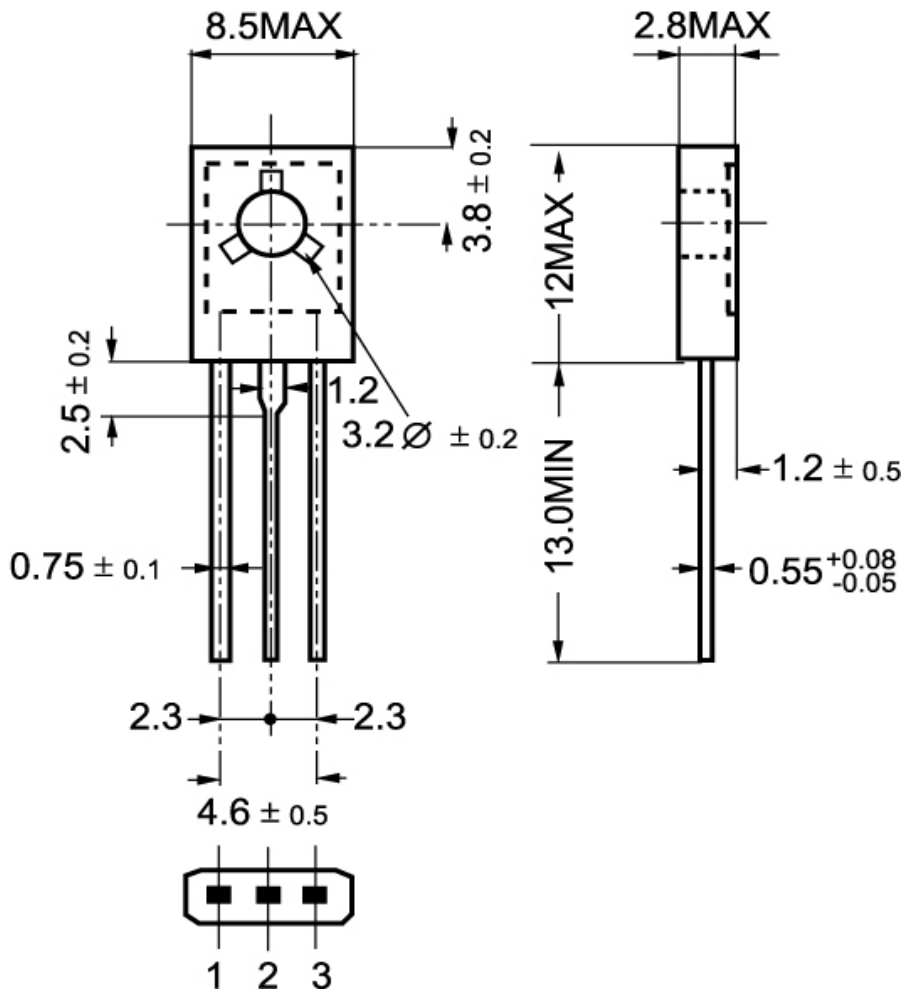

Fig.2 Outline dimensions