

6-Channel Quad-Mode™ Fractional LED Driver in TQFN3x3



FEATURES

- High efficiency 1.33x charge pump
- Quad-mode charge pump: 1x, 1.33x, 1.5x, 2x
- Drives up to 6 LEDs at 32mA each
- 1-wire EZDim™ LED current programming
- Power efficiency up to 92%
- Low noise input ripple in all modes
- “Zero” current shutdown mode
- Soft start and current limiting
- Short circuit protection
- Thermal shutdown protection
- Tiny 3mm x 3mm, 16-lead TQFN package

APPLICATIONS

- LCD Display Backlight
- Color RGB LEDs
- Cellular Phones
- Digital Still Cameras
- Handheld Devices

ORDERING INFORMATION

Part Number	Package	Quantity per Reel	Package Marking
CAT3636 HV3-T2	TQFN-16 3x3 Green	2000	JAAA

* Matte Tin Lead Finish

For Ordering Information details, see page 14.

PIN CONFIGURATION

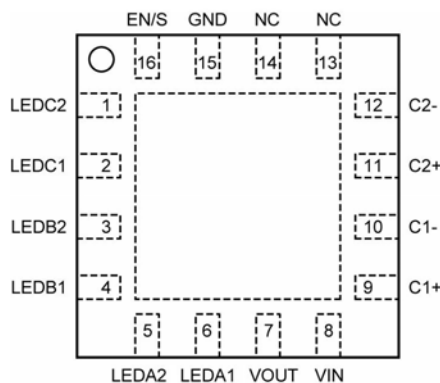

DESCRIPTION

The CAT3636 is a high efficiency quad-mode fractional charge pump that can drive up to six LEDs programmable by a one wire digital interface. The inclusion of a 1.33x fractional charge pump mode increases device efficiency by up to 10% over traditional 1.5x charge pumps with no added external capacitors.

Low noise input ripple is achieved by operating at a constant switching frequency which allows the use of small external ceramic capacitors. The multi-fractional charge pump supports a wide range of input voltages from 2.5V to 5.5V.

The EN/SET logic input functions as a chip enable and a “1-wire” addressable interface for control and current setting of all LEDs. Three groups of two LEDs can be configured with independent LED currents between 0.25mA and 32mA.

The device is available in a tiny 16-lead TQFN 3mm x 3mm package with a max height of 0.8mm.

The 1.33x charge pump with two fly capacitors is a patent pending architecture exclusive to Catalyst Semiconductor.

TYPICAL APPLICATION CIRCUIT

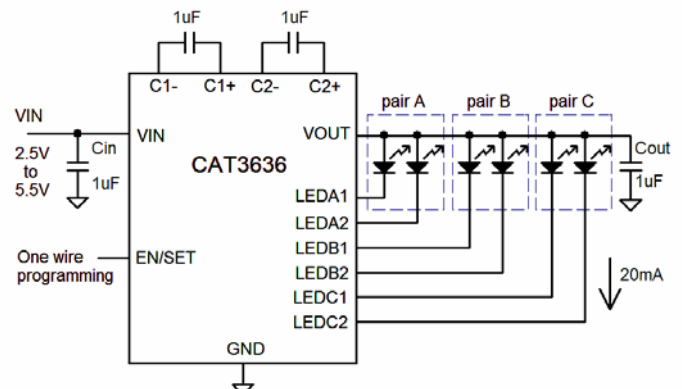

ABSOLUTE MAXIMUM RATINGS

Parameter	Rating	Unit
VIN, LEDx, C1±, C2± voltage	6	V
VOUT voltage	7	V
EN/SET voltage	VIN + 0.7V	V
Storage Temperature Range	-65 to +160	°C
Junction Temperature Range	-40 to +125	°C
Lead Temperature	300	°C

RECOMMENDED OPERATING CONDITIONS

Parameter	Rating	Unit
VIN	2.5 to 5.5	V
Ambient Temperature Range	-40 to +85	°C
I _{LED} per LED pin	0 to 32	mA
Total Output Current	0 to 192	mA

Typical application circuit with external components is shown on page 1.

ELECTRICAL OPERATING CHARACTERISTICS

(over recommended operating conditions unless specified otherwise) VIN = 3.6V, EN = High, T_{AMB} = 25°C

Symbol	Name	Conditions	Min	Typ	Max	Units
I _Q	Quiescent Current	1x mode, no load 1.33x mode, no load 1.5x mode, no load 2x mode, no load		0.5 3.5 3 2.5		mA mA mA mA
I _{QSHDN}	Shutdown Current	V _{EN} = 0V			1	µA
I _{LED-ACC}	LED Current Accuracy	1mA ≤ I _{LED} ≤ 31mA		±3		%
I _{LED-DEV}	LED Channel Matching	$\frac{I_{LED} - I_{LEDAVG}}{I_{LED}}$		±1		%
R _{OUT}	Output Resistance (open loop)	1x mode, I _{OUT} = 100mA 1.33x mode, I _{OUT} = 100mA 1.5x mode, I _{OUT} = 100mA 2x mode, I _{OUT} = 100mA		0.5 4.5 3.5 6		Ω Ω Ω Ω
F _{OSC}	Charge Pump Frequency	1.33x and 2x mode 1.5x mode	0.6 0.8	0.8 1.1	1.1 1.4	MHz MHz
I _{SC-MAX}	Output short circuit Current Limit	V _{OUT} < 0.5V		80		mA
LED _{TH}	1x to 1.33x or 1.33x to 1.5x or 1.5x to 2x Transition Thresholds at any LEDxx pin			150		mV
V _{HYS}	1.33x to 1x Transition Hysteresis			400		mV
T _{DF}	Transition Filter Delay			500		µs
I _{IN-MAX}	Input Current Limit	V _{OUT} > 1V		450		mA
I _{EN/DIM} V _{HI} V _{LO}	EN/DIM Pin • Input Leakage • Logic High Level • Logic Low Level		-1 1.3		1 0.4	µA V V
T _{SD}	Thermal Shutdown			150		°C
T _{HYS}	Thermal Hysteresis			20		°C
V _{UVLO}	Undervoltage lockout (UVLO) threshold			2		V

RECOMMENDED EN/SET TIMING

For $2.5 \leq V_{IN} \leq 5.5V$, over full ambient temperature range -40 to $+85^{\circ}C$.

Symbol	Name	Conditions	Min	Typ	Max	Units
T_{SETUP}	EN/SET setup from shutdown		10			μs
T_{LO}	EN/SET program low time		0.2		100	μs
T_{HI}	EN/SET program high time		0.2		100	μs
T_{OFF}	EN/SET low time to shutdown		1.5			ms
$T_{DATADELAY}$	EN/SET Delay to DATA		500		1000	μs
$T_{RESETDELAY}$	EN/SET Delay High to ADDRESS		2			ms

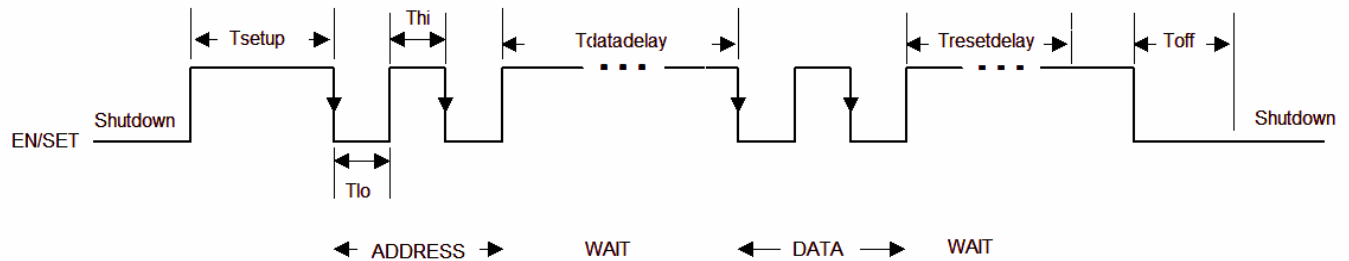

Figure 1. EN/SET One Wire Addressable Timing Diagram

CAT3636

TYPICAL PERFORMANCE CHARACTERISTICS

VIN = 3.6V, IOUT = 120mA (6 LEDs at 20mA), CIN = COUT = C1 = C2 = 1μF, TAMB = 25°C unless otherwise specified.

Efficiency vs. Input Voltage

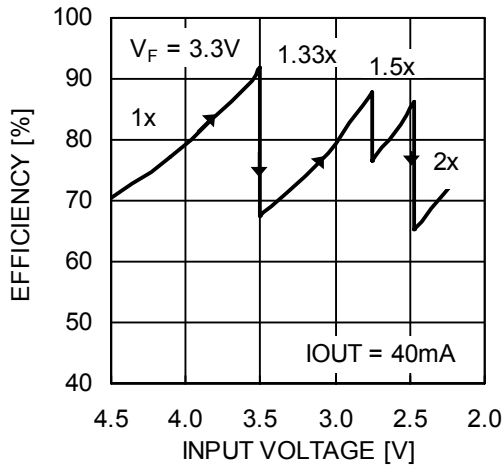

Efficiency vs. Li-Ion Voltage

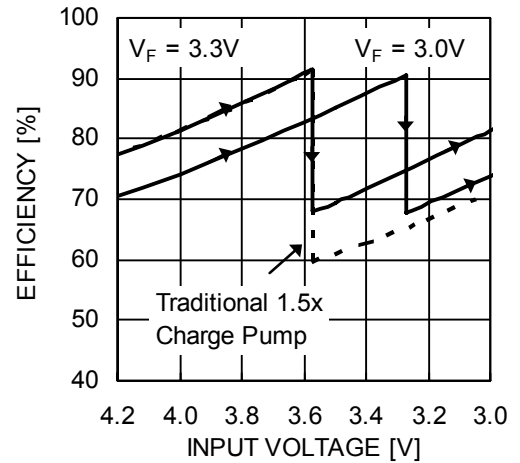

Quiescent Current vs. Input Voltage

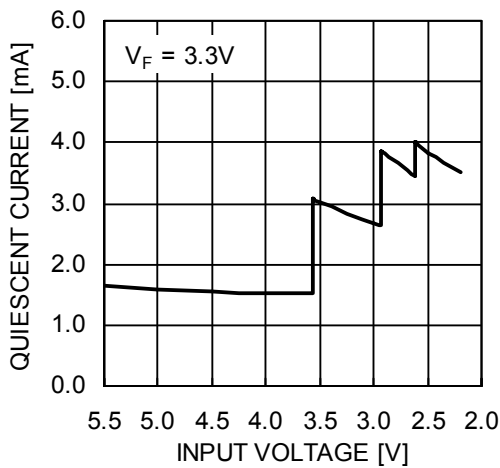

Quiescent Current vs. Temperature

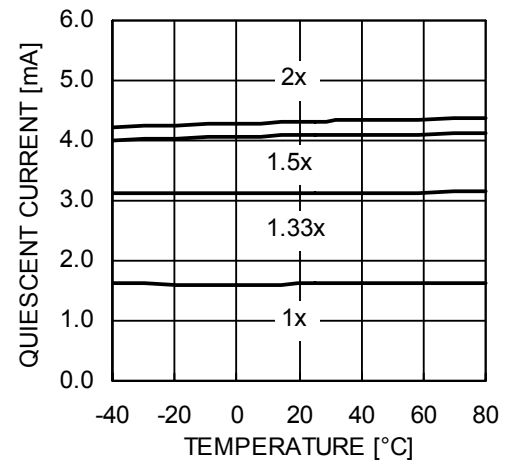

LED Current Change vs. Input Voltage

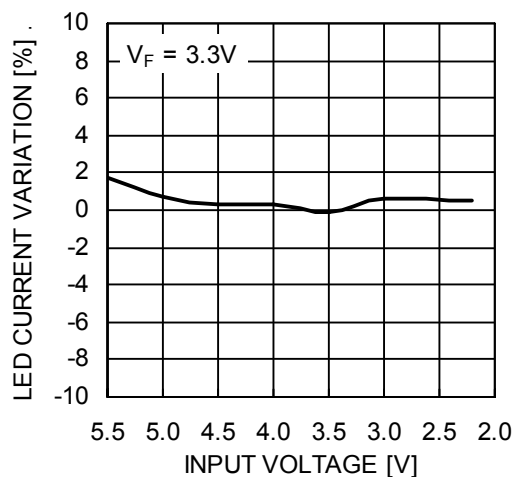

LED Current Change vs. Temperature

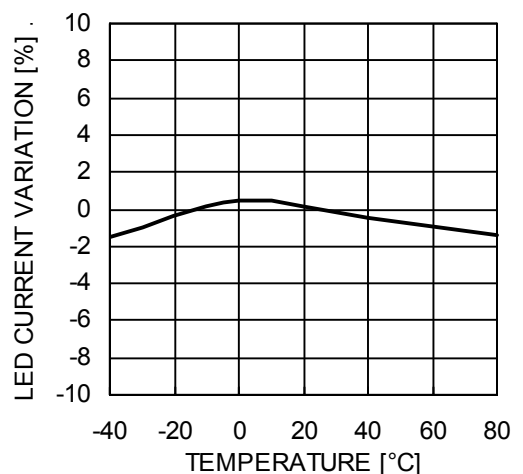

TYPICAL PERFORMANCE CHARACTERISTICS

$V_{IN} = 3.6V$, $I_{OUT} = 120mA$ (6 LEDs at 20mA), $C_{IN} = C_{OUT} = C1 = C2 = 1\mu F$, $T_{AMB} = 25^{\circ}C$ unless otherwise specified.

Switching Frequency vs. Temperature

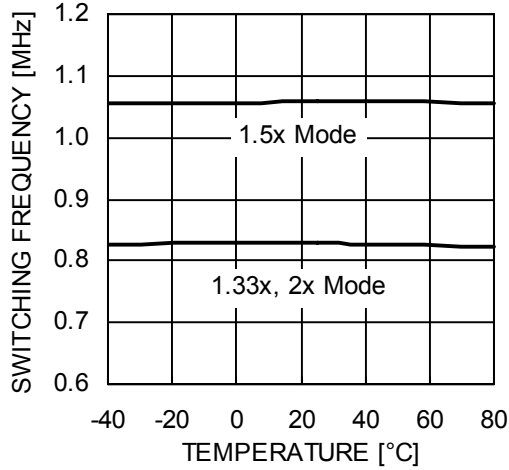

Output Resistance vs. Input Voltage

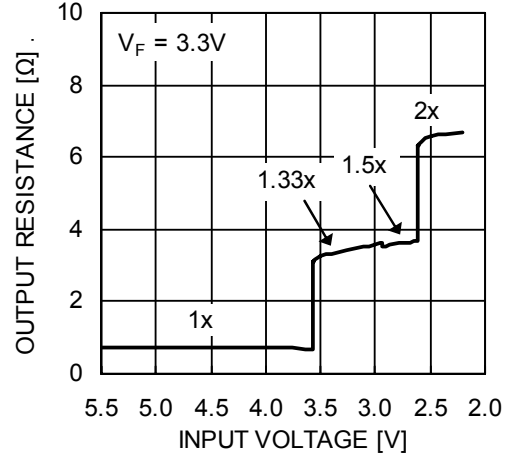

Power Up in 1x Mode

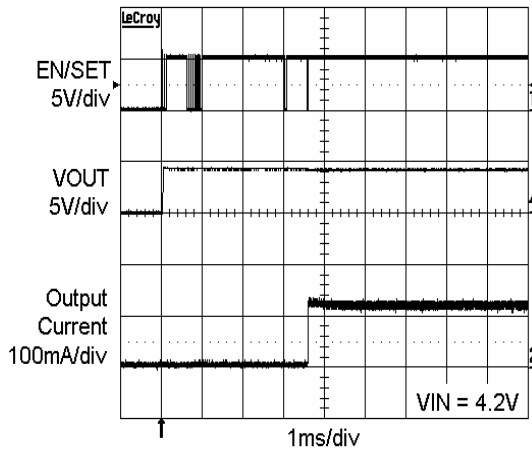

Power Up in 1.33x Mode

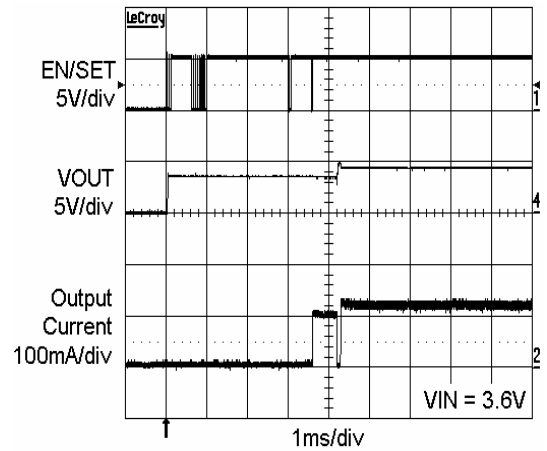

Power Up in 1.5x Mode

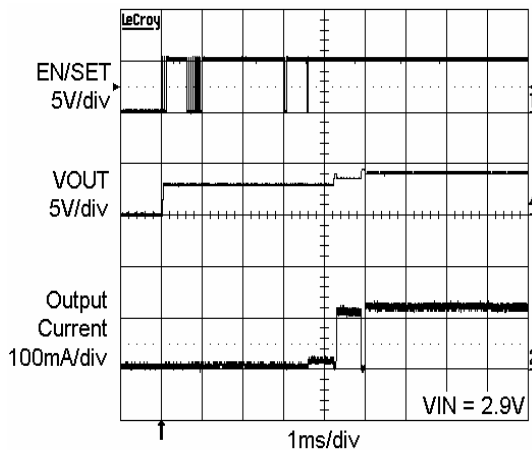

Power Up in 2x Mode

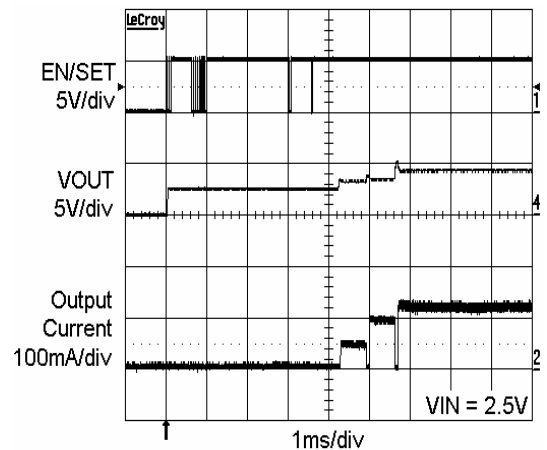

CAT3636

TYPICAL PERFORMANCE CHARACTERISTICS

VIN = 3.6V, IOUT = 120mA (6 LEDs at 20mA), CIN = COUT = C1 = C2 = 1μF, TAMB = 25°C unless otherwise specified.

Power Down Delay (1x Mode)

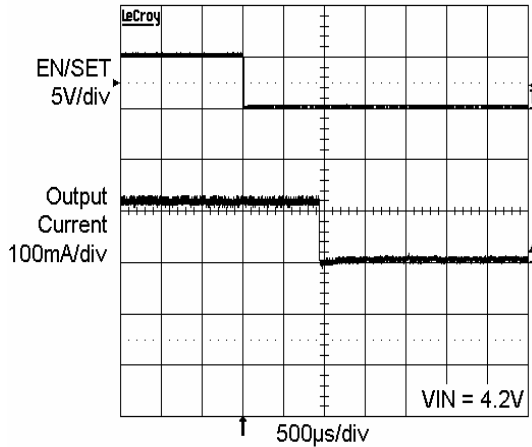

Foldback Current Limit

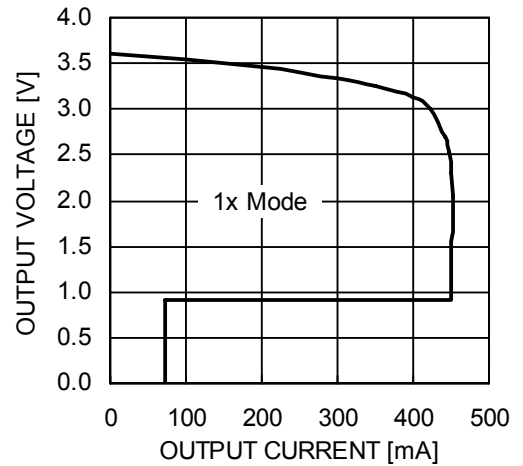

Operating Waveforms in 1x Mode

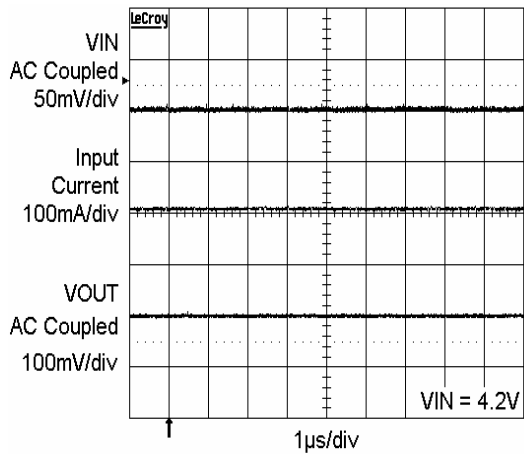

Switching Waveforms in 1.33x Mode

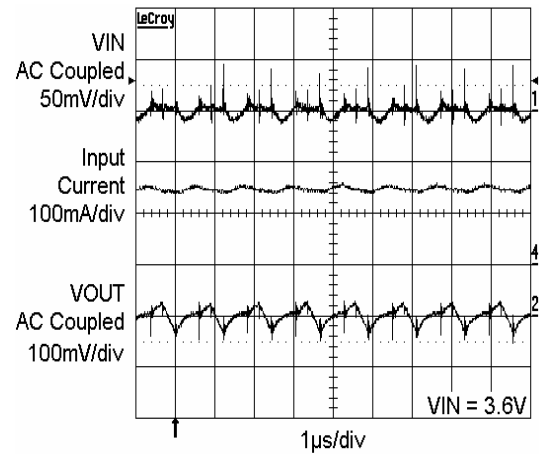

Switching Waveforms in 1.5x Mode

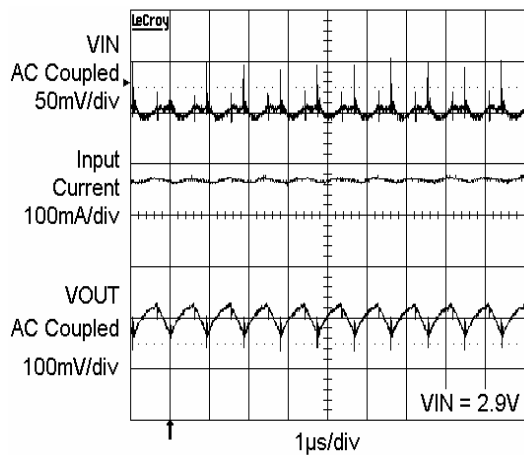

Switching Waveforms in 2x Mode

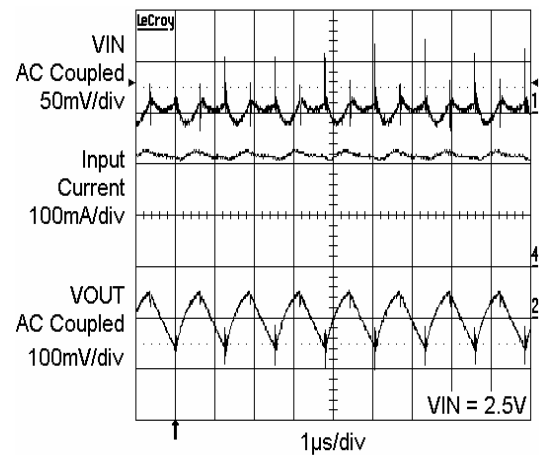

PIN DESCRIPTION

Pin #	Name	Function
1	LEDC2	LEDC2 cathode terminal
2	LEDC1	LEDC1 cathode terminal
3	LEDB2	LEDB2 cathode terminal
4	LEDB1	LEDB1 cathode terminal
5	LEDA2	LEDA2 cathode terminal
6	LEDA1	LEDA1 cathode terminal
7	VOUT	Charge pump output, connect to LED anodes
8	VIN	Charge pump input, connect to battery or supply
9	C1+	Bucket capacitor 1, positive terminal
10	C1-	Bucket capacitor 1, negative terminal
11	C2+	Bucket capacitor 2, positive terminal
12	C2-	Bucket capacitor 2, negative terminal
13/14	NC	No connect
15	GND	Ground reference
16	EN/SET	Device enable (active high) and 1 wire control input
TAB	TAB	Connect to GND on the PCB

PIN FUNCTION

VIN is the supply pin for the charge pump. A small 1 μ F ceramic bypass capacitor is required between the VIN pin and ground near the device. The operating input voltage range is from 2.5V to 5.5V. Whenever the input supply falls below the under-voltage threshold (2V) all the LED channels will be automatically disabled and the device register are reset to default values.

EN/SET is the enable and one wire addressable control logic input for all LED channels. Guaranteed levels of logic high and logic low are set at 1.3V and 0.4V respectively. When EN/SET is initially taken high, the device becomes enabled and all LED currents remain at 0mA. To place the device into zero current mode, the EN/SET pin must be held low for more than 1.5ms.

VOUT is the charge pump output that is connected to the LED anodes. A small 1 μ F ceramic bypass capacitor is required between the VOUT pin and ground near the device.

GND is the ground reference for the charge pump. The pin must be connected to the ground plane on the PCB.

C1+, C1- are connected to each side of the ceramic bucket capacitor C1.

C2+, C2- are connected to each side of the ceramic bucket capacitor C2.

LEDxx provide the internal regulated current for each of the LED cathodes. These pins enter high-impedance zero current state whenever the device is placed in shutdown mode.

TAB is the exposed pad underneath the package. For best thermal performance, the tab should be soldered to the PCB and connected to the ground plane.

BLOCK DIAGRAM

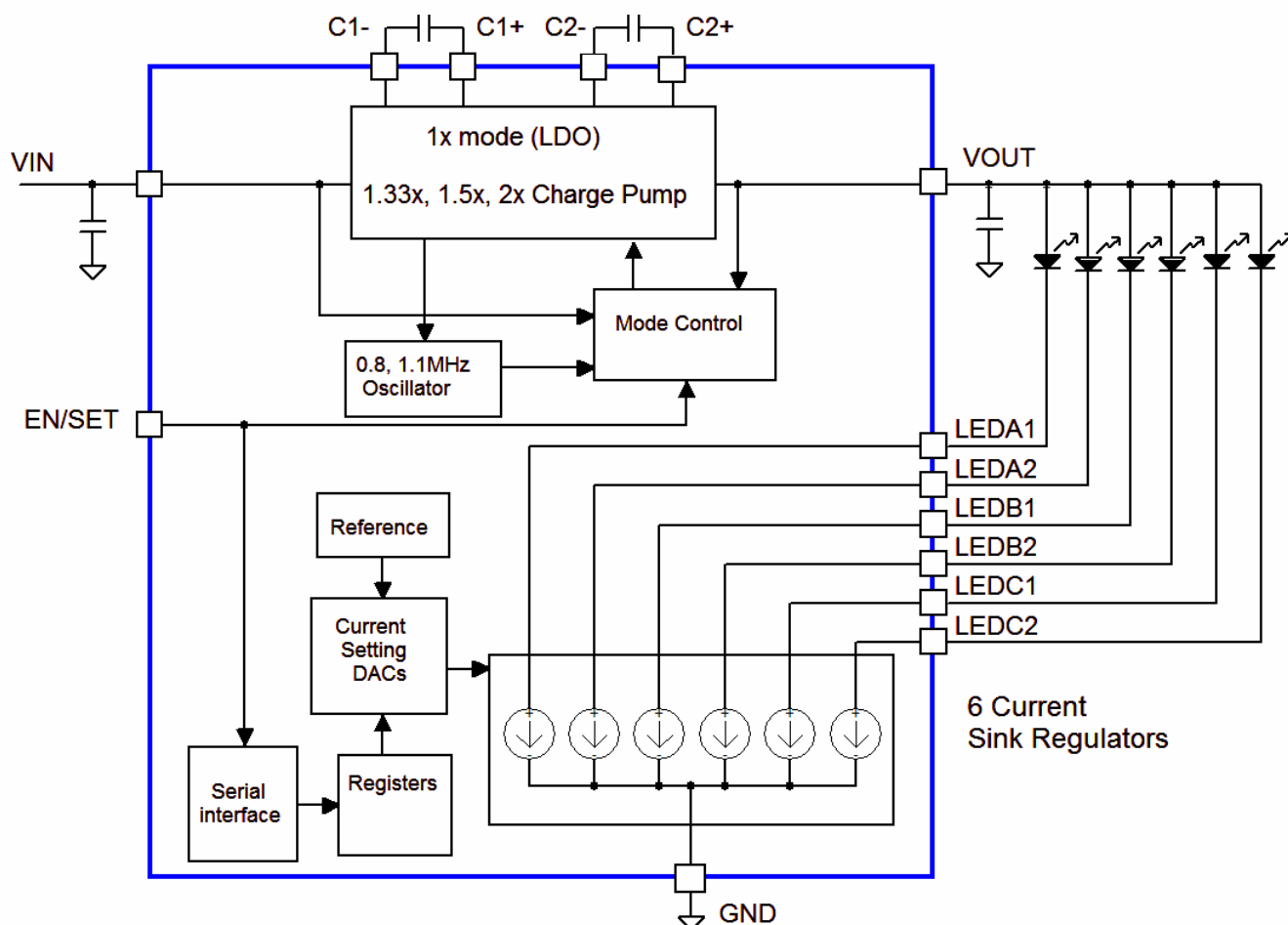

Figure 2. CAT3636 Functional Block Diagram

BASIC OPERATION

At power-up, the CAT3636 starts operating in 1x mode where the output will be approximately equal to the input supply voltage (less any internal voltage losses). If the output voltage is sufficient to regulate all LED currents, the device remains in 1x operating mode.

If the input voltage is insufficient or falls to a level where the regulated currents cannot be maintained, the device automatically switches into 1.33x mode (after a fixed delay time of about 400µs). In 1.33x mode, the output voltage is approximately equal to 1.33 times the input supply voltage (less any internal voltage losses).

If the input voltage is insufficient again or falls to a level where the regulated currents cannot be maintained, the device will automatically switch to the 1.5x boost mode (after a fixed delay time of about

400µs). In 1.5x mode, the output is approximately equal to 1.5 times the input supply voltage (less any internal voltage losses).

If the input voltage fails more or is still insufficient to drive the LEDs, it will automatically switch again into 2x mode where the output is approximately equal to 2 times the input supply voltage (less any internal voltage losses).

If the device detects a sufficient input voltage is present to drive all LED currents in 1x mode, it will change automatically back to 1x mode. This only applies for changing back to the 1x mode.

LED Current Setting

The current in each of the six LED channels is programmed through the 1-wire EN/SET digital control input. By pulsing this signal according to a specific protocol, a set of internal registers can be addressed and written into allowing to configure each bank of LEDs with the desired current. There are six registers: the first five are 4 bits long and the sixth is 1 bit long. The registers are programmed by first selecting the register address and then programming data into that register.

An internal counter records the number of falling edges to identify the address and data. The address is serially programmed adhering to low and high duration time delays. One down pulse corresponds to register 1 being selected. Two down pulses correspond to register 2 being selected and so on up to register 6. T_{LO} and T_{HI} must be within 200ns to 100µs. Anything below 200ns may be ignored.

Once the final rising edge of the address pointer is programmed, the user must wait 500µs to 1000µs before programming the first data pulse falling edge. If the falling edge of the data is not received within 1000µs, the device will revert back to waiting for an address.

Data in a register is reset once it is selected by the address pointer. If a register is selected but no data is programmed, then the register value is reset back to its initial default value with all data bits to 0.

Once the final rising edge of the data pulses is programmed, the user must wait 1.5ms before programming another address. If programming fails or is interrupted, the user must wait $T_{RESETDELAY}$ 2ms from the last rising edge before reprogramming can commence.

Upon power-up, the device automatically starts looking for an address. If no falling edge is detected within 100µs of power-up, then the user must wait 2ms before trying to program the device again.

The device requires a minimum 10µs delay to ensure the initialization of the internal logic at power-up. After this time delay, the device registers may be programmed adhering to the timing constraints shown in Figure 1.

To power-down the device and turn-off all current sources, the EN/SET input should be kept low for a duration T_{OFF} of 1.5ms or more. The driver typically powers-down with a delay of about 1ms. All register data are lost.

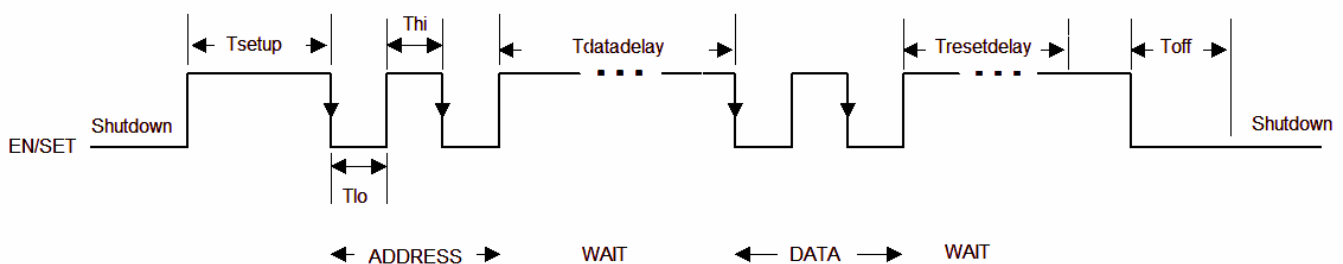

Figure 3. EN/SET One Wire Addressable Timing Diagram

CAT3636
REGISTER CONFIGURATION AND PROGRAMMING
Table 1. Register Address and Data

Register	Address Pulses	Description	Bits	DATA pattern			
				Bit 3	Bit 2	Bit 1	Bit 0
REG1	1	Bank Enable and IMODE	4	IMODE	ENA	ENB	ENC
REG2	2	Global Current Setting	4	See Table 2 for values			
REG3	3	Bank A Current Setting	4				
REG4	4	Bank B Current Setting	4				
REG5	5	Bank C Current Setting	4				
REG6	6	Return Lockout	1				RTLKO

Table 2. REG2-5 Current Setting Registers

Data Pulses	REG1-6 Value (binary)	LED Current IMODE = 0	LED Current IMODE = 1
0	0000	0.0mA	2mA
1	1111	3.75mA	32mA
2	1110	3.5mA	30mA
3	1101	3.25mA	28mA
4	1100	3mA	26mA
5	1011	2.75mA	24mA
6	1010	2.5mA	22mA
7	1001	2.25mA	20mA
8	1000	2mA	18mA
9	0111	1.75mA	16mA
10	0110	1.5mA	14mA
11	0101	1.25mA	12mA
12	0100	1mA	10mA
13	0011	0.75mA	8mA
14	0010	0.5mA	6mA
15	0001	0.25mA	4mA
16	0000	0.0mA	2mA

Register REG1 allows to set the mode and select the pairs of LEDs to be turned on. A low LED current mode exists to allow for very low current operation under 4mA per channel. If IMODE equals 1, the high current range is selected up to 32mA. If IMODE is set to 0, all currents are divided by 8. Each bank of LEDs (A, B or C) can be turned on independently by setting the respective bit ENA, ENB, ENC to 1.

Register REG2 allows to set the same current for all 6 channels. REG3, REG4, REG5 allow to set the current respectively in banks A, B and C. The three banks can be programmed with independent current values.

REG6 contains the return lockout (RTLKO) bit. This stops the charge pump returning to 1x mode. One pulse sets it to 1. Two pulses or no pulses set RTLKO to 0. When RTLKO is set to 1, the charge pump cannot automatically return to 1x mode when in one of the charge pump modes. The device can however move from 1x to 1.33x to 1.5x to 2x if the input voltage is not sufficient to drive the programmed LED currents.

REG6 also triggers a charge pump reset as soon as it is addressed. This forces the charge pump to start from 1x mode and reassess the correct mode it should be in to drive the LEDs most efficiently. If the input voltage has risen or the device has been reprogrammed to other LED values, it is recommended to trigger this reset allowing the charge pump to run in the most efficient mode.

The CAT3636 enters a “zero current” shutdown mode if EN/SET is held low for 1.5ms or more. All registers are reset back to zero when the device is placed in shutdown.

PROGRAMMING EXAMPLES

Programming 6 LEDs to 20mA

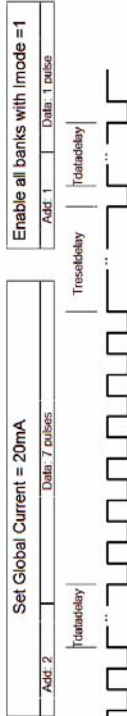
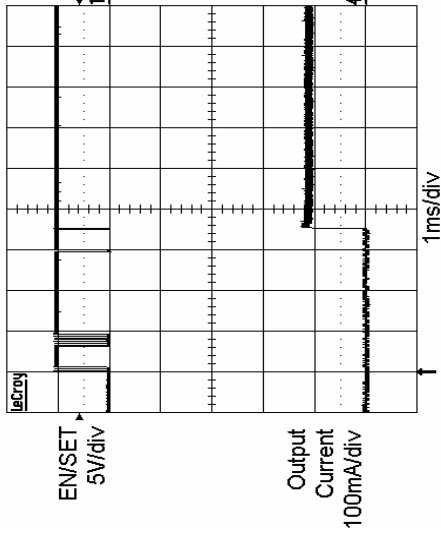

Programming 6 LEDs to 32mA

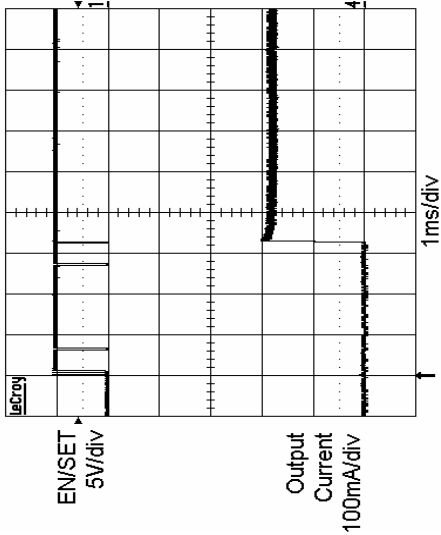

Programming 6 LEDs to 1mA

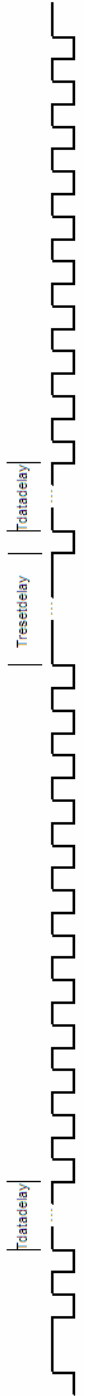
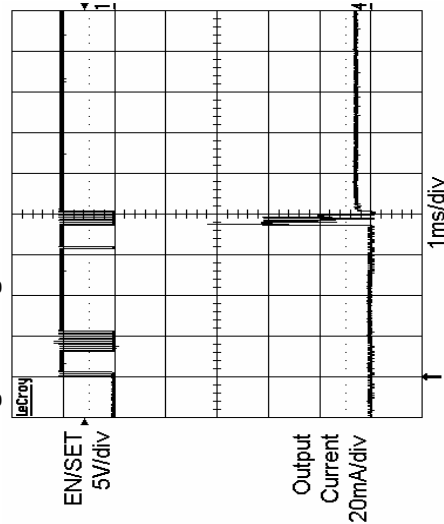

CAT3636

Unused LED Channels

For applications with only four or two LEDs, unused LED banks can be disabled via the enable register internally and left to float.

For applications with 5 LEDs or less, unused LEDs can also be disabled by connecting the LED pin directly to VOUT, as shown on Figure 4. If LED pin voltage is within 1V of VOUT, then the channel is switched off and a 200 μ A test current is placed in the channel to sense when the channel moves below VOUT - 1V.

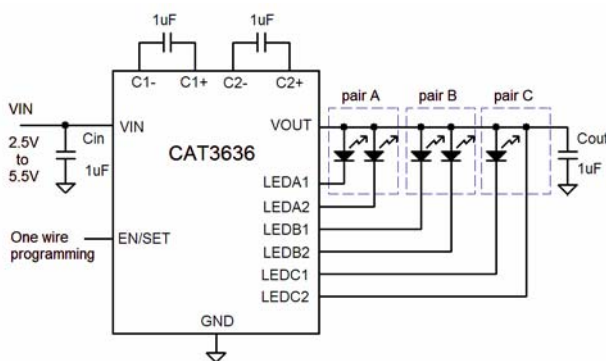

Figure 4. Five LED Application

Protection Mode

If an LED is disconnected, the output voltage VOUT automatically limits at about 5.5V. This is to prevent the output pin from exceeding its absolute maximum rating.

If the die temperature exceeds +150°C the driver will enter a thermal protection shutdown mode. When the device temperature drops by about 20°C the device will resume normal operation.

LED Selection

LEDs with forward voltages (V_F) ranging from 1.3V to 5.0V may be used with the CAT3636. Selecting LEDs with lower V_F is recommended in order to improve the efficiency by keeping the driver in 1x mode longer as the battery voltage decreases.

For example, if a white LED with a V_F of 3.3V is selected over one with V_F of 3.5V, the CAT3636 will stay in 1x mode for lower supply voltage of 0.2V. This helps improve the efficiency and extends battery life.

External Components

The driver requires two external 1 μ F ceramic capacitors for decoupling input, output, and for the charge pump. Both capacitors type X5R and X7R are recommended for the LED driver application. In all charge pump modes, the input current ripple is kept very low by design and an input bypass capacitor of 1 μ F is sufficient.

In 1x mode, the device operates in linear mode and does not introduce switching noise back onto the supply.

Recommended Layout

In charge pump mode, the driver switches internally at a high frequency. It is recommended to minimize trace length to all four capacitors. A ground plane should cover the area under the driver IC as well as the bypass capacitors. Short connection to ground on capacitors CIN and COUT can be implemented with the use of multiple via. A copper area matching the TQFN exposed pad (TAB) must be connected to the ground plane underneath. The use of multiple via improves the package heat dissipation.

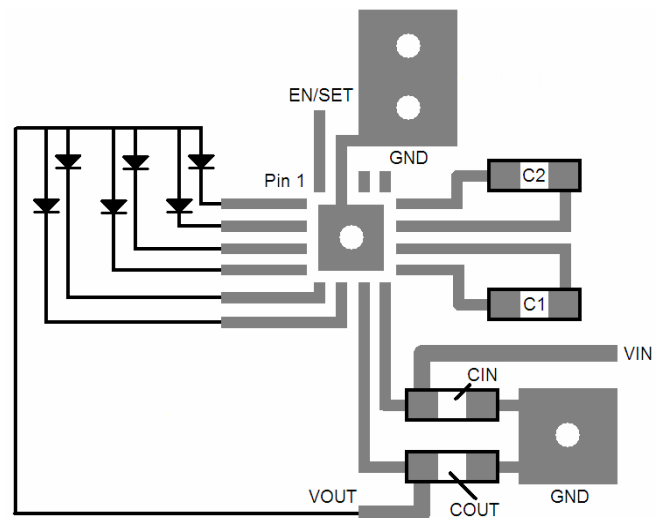
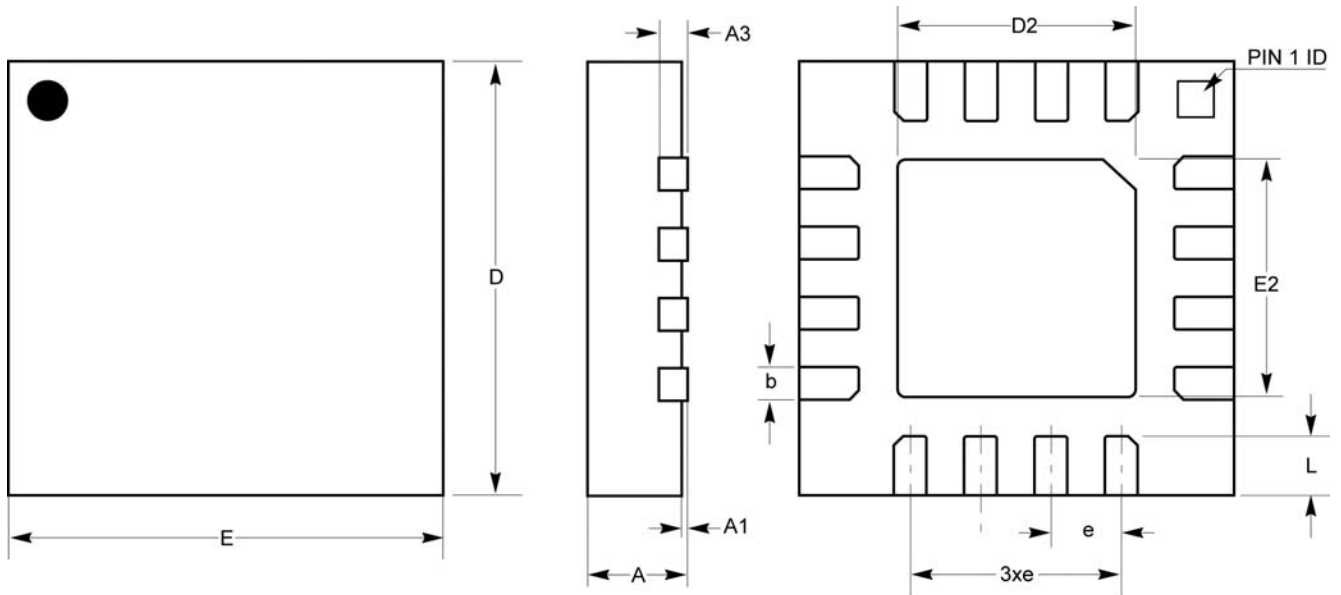

Figure 5. Recommended Layout

PACKAGE OUTLINES
16 Lead TQFN (HV3)



SYMBOL	MIN	NOM	MAX
A	0.70	0.75	0.80
A1	0.00	0.02	0.05
A3	0.178	0.203	0.228
b	0.18	0.23	0.28
D	2.90	3.00	3.10
D2	1.40	1.55	1.70
E	2.90	3.00	3.10
E2	1.40	1.55	1.70
e		0.50 TYP	
L	0.35	0.40	0.45

Notes:

- (1) All dimensions are in millimeters, angles in degrees.
- (2) Complies with JEDEC Standard MO-220.

For current Tape & Reel information, download the pdf file from:
<http://www.catsemi.com/documents/tapeandreel.pdf>

CAT3636

EXAMPLE OF ORDERING INFORMATION

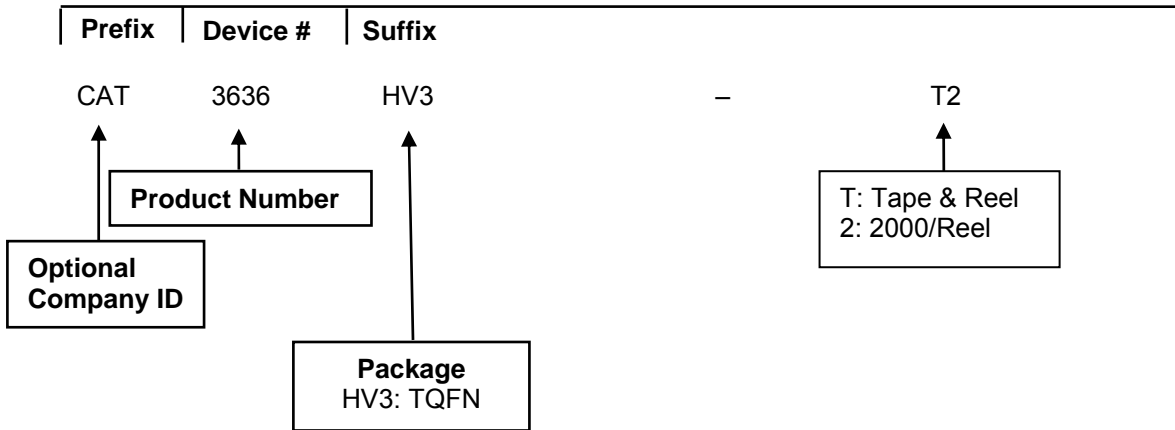

Notes:

- (1) All packages are RoHS-compliant (Lead-free, Halogen-free).
- (2) The standard lead finish is Matte-Tin.
- (3) The device used in the above example is a CAT3636HV3-T2 (TQFN, Tape & Reel).
- (4) For additional package and temperature options, please contact your nearest Catalyst Semiconductor Sales office.

REVISION HISTORY

Date	Rev.	Reason
09/08/06	A	Initial Issue

Copyrights, Trademarks and Patents

Trademarks and registered trademarks of Catalyst Semiconductor include each of the following:

DPP [™] AE2 [™] Quad-Mode [™]

Catalyst Semiconductor has been issued U.S. and foreign patents and has patent applications pending that protect its products.

CATALYST SEMICONDUCTOR MAKES NO WARRANTY, REPRESENTATION OR GUARANTEE, EXPRESS OR IMPLIED, REGARDING THE SUITABILITY OF ITS PRODUCTS FOR ANY PARTICULAR PURPOSE, NOR THAT THE USE OF ITS PRODUCTS WILL NOT INFRINGE ITS INTELLECTUAL PROPERTY RIGHTS OR THE RIGHTS OF THIRD PARTIES WITH RESPECT TO ANY PARTICULAR USE OR APPLICATION AND SPECIFICALLY DISCLAIMS ANY AND ALL LIABILITY ARISING OUT OF ANY SUCH USE OR APPLICATION, INCLUDING BUT NOT LIMITED TO, CONSEQUENTIAL OR INCIDENTAL DAMAGES.

Catalyst Semiconductor products are not designed, intended, or authorized for use as components in systems intended for surgical implant into the body, or other applications intended to support or sustain life, or for any other application in which the failure of the Catalyst Semiconductor product could create a situation where personal injury or death may occur.

Catalyst Semiconductor reserves the right to make changes to or discontinue any product or service described herein without notice. Products with data sheets labeled "Advance Information" or "Preliminary" and other products described herein may not be in production or offered for sale.

Catalyst Semiconductor advises customers to obtain the current version of the relevant product information before placing orders. Circuit diagrams illustrate typical semiconductor applications and may not be complete.



Catalyst Semiconductor, Inc.
Corporate Headquarters
2975 Stender Way
Santa Clara, CA 95054
Phone: 408.542.1000
Fax: 408.542.1200
www.catsemi.com

Document No: 5020
Revision: A
Issue date: 09/08/06