



Ultralow Noise VGAs with Preamplifier and Programmable R_{IN}

AD8331/AD8332

FEATURES

Ultralow noise preamplifier

Voltage noise = 0.74 nV/ $\sqrt{\text{Hz}}$

Current noise = 2.5 pA/ $\sqrt{\text{Hz}}$

3 dB bandwidth: 120 MHz

Low power: 125 mW/channel

Wide gain range with programmable postamp

-4.5 dB to +43.5 dB

+7.5 dB to +55.5 dB

Low output-referred noise: 48 nV/ $\sqrt{\text{Hz}}$ typical

Active input impedance matching

Optimized for 10-/12-bit ADCs

Selectable output clamping level

Single 5 V supply operation

Available in space-saving chip scale package

APPLICATIONS

Ultrasound and sonar time-gain control

High performance AGC systems

I/Q signal processing

High speed dual ADC driver

GENERAL DESCRIPTION

The AD8331/AD8332 are single- and dual-channel ultralow noise, linear-in-dB, variable gain amplifiers. Although optimized for ultrasound systems, they are usable as low noise variable gain elements at frequencies up to 120 MHz.

Each channel consists of an ultralow noise preamplifier (LNA), an X-AMP[®] VGA with 48 dB of gain range, and a selectable gain postamplifier with adjustable output limiting. The LNA gain is 19 dB with a single-ended input and differential outputs capable of accurate, programmable active input impedance matching by selecting an external feedback resistor. Active impedance control optimizes noise performance for applications that benefit from input matching.

The 48 dB gain range of the VGA makes these devices suitable for a variety of applications. Excellent bandwidth uniformity is maintained across the entire range. The gain control interface provides precise linear-in-dB scaling of 50 dB/V for control voltages between 40 mV and 1 V. Factory trim ensures excellent part-to-part and channel-to-channel gain matching. Differential signal paths lead to superb second and third order distortion performance and low crosstalk.

FUNCTIONAL BLOCK DIAGRAM

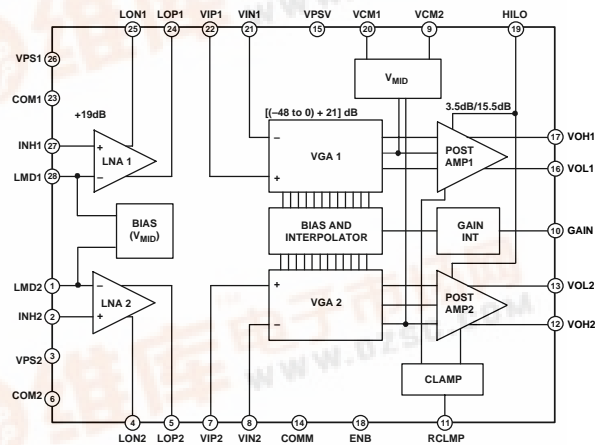

Figure 1. AD8332 Shown 28-Lead TSSOP

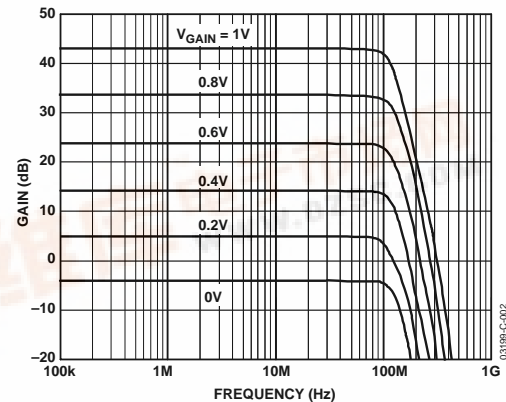

Figure 2. Frequency Response vs. Gain

The VGA's low output-referred noise is advantageous in driving high speed differential ADCs. The gain of the postamplifier may be pin selected to 3.5 dB or 15.5 dB to optimize gain range and output noise for 12-bit or 10-bit converter applications. The output may be limited to a user-selected clamping level, preventing input overload to a subsequent ADC. An external resistor adjusts the clamping level.

The operating temperature range is -40°C to $+85^{\circ}\text{C}$. The AD8331 is available in a 20-lead QSOP package, and the AD8332 in 28-lead TSSOP and 32-lead LFCSP packages. They require a single 5 V supply, and the quiescent power consumption is 125 mW/ch. A power-down (enable) pin is provided.



AD8331/AD8332

TABLE OF CONTENTS

REVISION HISTORY	2
AD8331, AD8332—Specifications.....	3
Absolute Maximum Ratings.....	6
ESD CAUTION	6
AD8331, AD8332—Typical Performance Characteristics	7
Test Circuits.....	15
Theory of Operation	17
Overview.....	17
Low Noise Amplifier (LNA).....	17
Variable Gain Amplifier.....	19
Postamplifier	21
Applications.....	22

LNA – External Components	22
Driving ADCs	24
Overload	24
Optional Input Overload Protection	25
Layout, Grounding, And Bypassing	25
Multiple Input Matching	25
Disabling the LNA.....	25
Measurement Considerations.....	26
Ultrasound TGC Application	26
Pin Configuration and Function Descriptions.....	30
AD8331	30
AD8332.....	31
Outline Dimensions	32
Ordering Guide	32

REVISION HISTORY

Revision C

11/03—Data Sheet Changed from REV. B to REV. C

Addition of New Part.....	Universal
Changes to Figures	Universal
Updated Outline Dimensions.....	32

5/03—Data Sheet Changed from REV. A to REV. B

Edits to Ordering Guide.....	32
Edits to Ultrasound TGC Application section.....	25
Added Figure 71, Figure 72, and Figure 73.....	26
Updated Outline Dimensions.....	31

2/03—Data Sheet Changed from REV. 0 to REV. A

Edits to Ordering Guide.....	32
------------------------------	----

AD8331, AD8332—SPECIFICATIONS

Table 1. $T_A = 25^\circ\text{C}$, $V_S = 5\text{ V}$, $R_L = 500\ \Omega$, $R_S = R_{IN} = 50\ \Omega$, $R_{FB} = 280\ \Omega$, $C_{SH} = 22\ \text{pF}$, $f = 10\ \text{MHz}$, $R_{CLMP} = \infty$, $C_L = 1\ \text{pF}$, V_{CM} pin floating, $-4.5\ \text{dB}$ to $+43.5\ \text{dB}$ gain (HILO = LO), and differential output voltage, unless otherwise specified.

Parameter	Conditions	Min	Typ	Max	Unit
LNA CHARACTERISTICS					
Gain	Single-Ended Input to Differential Output		19		dB
	Input to Output (Single-Ended)		13		dB
Input Voltage Range	AC-Coupled		± 275		mV
Input Resistance	$R_{FB} = 280\ \Omega$		50		Ω
	$R_{FB} = 412\ \Omega$		75		Ω
	$R_{FB} = 562\ \Omega$		100		Ω
	$R_{FB} = 1.13\ \text{k}\Omega$		200		Ω
	$R_{FB} = \infty$		6		k Ω
Input Capacitance			13		pF
Output Impedance	Single-Ended, Either Output		5		Ω
-3 dB Small Signal Bandwidth	$V_{OUT} = 0.2\ \text{V p-p}$		130		MHz
Slew Rate			650		V/ μs
Input Voltage Noise	$R_S = 0\ \Omega$, HI or LO Gain, $R_{FB} = \infty$, $f = 5\ \text{MHz}$		0.74		nV/ $\sqrt{\text{Hz}}$
Input Current Noise	$R_{FB} = \infty$, HI or LO Gain, $f = 5\ \text{MHz}$		2.5		pA/ $\sqrt{\text{Hz}}$
Noise Figure	$f = 10\ \text{MHz}$, LOP Output				
	Active Termination Match	$R_S = R_{IN} = 50\ \Omega$		3.7	dB
	Unterminated	$R_S = 50\ \Omega$, $R_{FB} = \infty$		2.5	dB
Harmonic Distortion @ LOP1 or LOP2	$V_{OUT} = 0.5\ \text{V p-p}$, Single-Ended, $f = 10\ \text{MHz}$			-56	dBc
				-70	dBc
Output Short-Circuit Current	Pins LON, LOP		165		mA
LNA + VGA CHARACTERISTICS					
-3 dB Small Signal Bandwidth	$V_{OUT} = 0.2\ \text{V p-p}$		120		MHz
-3 dB Large Signal Bandwidth	$V_{OUT} = 2\ \text{V p-p}$		110		MHz
Slew Rate	LO Gain		300		V/ μs
	HI Gain		1200		V/ μs
Input Voltage Noise	$R_S = 0\ \Omega$, HI or LO Gain, $R_{FB} = \infty$, $f = 5\ \text{MHz}$		0.82		nV/ $\sqrt{\text{Hz}}$
Noise Figure	$V_{GAIN} = 1.0\ \text{V}$				
	Active Termination Match	$R_S = R_{IN} = 50\ \Omega$, $f = 10\ \text{MHz}$, Measured		4.15	dB
		$R_S = R_{IN} = 200\ \Omega$, $f = 5\ \text{MHz}$, Simulated		2.0	dB
	Unterminated	$R_S = 50\ \Omega$, $R_{FB} = \infty$, $f = 10\ \text{MHz}$, Measured		2.5	dB
		$R_S = 200\ \Omega$, $R_{FB} = \infty$, $f = 5\ \text{MHz}$, Simulated		1.0	dB
Output-Referred Noise	$V_{GAIN} = 0.5\ \text{V}$, LO Gain		48		nV/ $\sqrt{\text{Hz}}$
	$V_{GAIN} = 0.5\ \text{V}$, HI Gain		178		nV/ $\sqrt{\text{Hz}}$
Output Impedance, Postamplifier	DC to 1 MHz		1		Ω
Output Signal Range, Postamplifier	$R_L \geq 500\ \Omega$, Unclamped, Either Pin		$V_{CM} \pm 1.125$		V
			4.5		V p-p
Output Offset Voltage	$V_{GAIN} = 0.5\ \text{V}$	Differential		-50	mV
		Common-Mode		-125	-25
Output Short-Circuit Current			45		mA

AD8331/AD8332

Parameter	Conditions	Min	Typ	Max	Unit
Harmonic Distortion	$V_{GAIN} = 0.5\text{ V}$, $V_{OUT} = 1\text{ V p-p}$				
HD2	$f = 1\text{ MHz}$		-88		dBc
HD3			-85		dBc
HD2	$f = 10\text{ MHz}$		-68		dBc
HD3			-65		dBc
Input 1 dB Compression Point	$V_{GAIN} = 0.25\text{ V}$, $V_{OUT} = 1\text{ V p-p}$, $f = 1\text{ MHz} - 10\text{ MHz}$		7		dBm ¹
Two-Tone Intermodulation Distortion (IMD3)	$V_{GAIN} = 0.72\text{ V}$, $V_{OUT} = 1\text{ V p-p}$, $f = 1\text{ MHz}$		-80		dBc
Output Third Order Intercept	$V_{GAIN} = 0.5\text{ V}$, $V_{OUT} = 1\text{ V p-p}$, $f = 1\text{ MHz}$		38		dBm
	$V_{GAIN} = 0.5\text{ V}$, $V_{OUT} = 1\text{ V p-p}$, $f = 10\text{ MHz}$		33		dBm
Channel-to-Channel Crosstalk (AD8332)	$V_{GAIN} = 0.5\text{ V}$, $V_{OUT} = 1\text{ V p-p}$, $f = 1\text{ MHz}$		-84		dB
Overload Recovery	$V_{GAIN} = 1.0\text{ V}$, $V_{IN} = 50\text{ mV p-p}/1\text{ V p-p}$, $f = 10\text{ MHz}$		5		ns
Group Delay Variation	$5\text{ MHz} < f < 50\text{ MHz}$, Full Gain Range		± 2		ns
ACCURACY					
Absolute Gain Error ²	$0.05\text{ V} < V_{GAIN} < 0.10\text{ V}$	-1	+0.5	+2	dB
	$0.10\text{ V} < V_{GAIN} < 0.95\text{ V}$	-1	± 0.3	+1	dB
	$0.95\text{ V} < V_{GAIN} < 1.0\text{ V}$	-2	-1	+1	dB
Gain Law Conformance ³	$0.1\text{ V} < V_{GAIN} < 0.95\text{ V}$		± 0.2		dB
Channel-to-Channel Gain Matching	$0.1\text{ V} < V_{GAIN} < 0.95\text{ V}$		± 0.1		dB
GAIN CONTROL INTERFACE (Pin GAIN)					
Gain Scaling Factor	$0.10\text{ V} < V_{GAIN} < 0.95\text{ V}$		50		dB/V
Gain Range	LO Gain		-4.5 to +43.5		dB
	HI Gain		+7.5 to +55.5		dB
Input Voltage (V_{GAIN}) Range			0 to 1.0		V
Input Impedance			10		M Ω
Response Time	48 dB Gain Change to 90% Full Scale		750		ns
COMMON-MODE INTERFACE (Pin VCMn)					
Input Resistance	Current Limited to $\pm 1\text{ mA}$		30		Ω
Output CM Offset Voltage	$V_{CM} = 2.5\text{ V}$	-125	-25	+100	mV
Voltage Range	$V_{OUT} = 2.0\text{ V p-p}$		1.5 to 3.5		V
ENABLE INTERFACE (Pins ENB, ENBL, ENBV)					
Logic Level to Enable Power		2.25		5	V
Logic Level to Disable Power		0		1.0	V
Input Resistance	Pin ENB		25		k Ω
	Pin ENBL		40		k Ω
	Pin ENBV		70		k Ω
Power-Up Response Time	$V_{INH} = 30\text{ mV p-p}$		300		μs
	$V_{INH} = 150\text{ mV p-p}$		4		ms
HILO GAIN RANGE INTERFACE (Pin HILO)					
Logic Level to Select HI Gain Range		2.25		5	V
Logic Level to Select LO Gain Range		0		1.0	V
Input Resistance			50		k Ω

¹ All dBm values are referred to 50 Ω , unless otherwise noted.

² Conformance to theoretical gain expression (see Equation 1).

³ Conformance to best fit dB linear curve.

AD8331/AD8332

Parameter	Conditions	Min	Typ	Max	Unit
OUTPUT CLAMP INTERFACE (Pin RCLMP; HI or LO Gain)					
Accuracy					
HILO = LO	$R_{CLMP} = 2.74 \text{ k}\Omega, V_{OUT} = 1 \text{ V p-p (Clamped)}$		± 50		mV
HILO = HI	$R_{CLMP} = 2.21 \text{ k}\Omega, V_{OUT} = 1 \text{ V p-p (Clamped)}$		± 75		mV
MODE INTERFACE (Pin MODE)					
Logic Level for Positive Gain Slope		0		1.0	V
Logic Level for Negative Gain Slope		2.25		5	V
Input Resistance			200		k Ω
POWER SUPPLY (Pins VPS1, VPS2, VPSV, VPSL, VPOS)					
Supply Voltage		4.5	5.0	5.5	V
Quiescent Current per Channel			25		mA
Power Dissipation per channel	No Signal		125		mW
Disable Current					
AD8332 (VGA and LNA)			300	600	μ A
AD8331 (VGA and LNA)			240	400	μ A
AD8332 (ENBL)	Each Channel		12		mA
AD8332 (ENBV)	Each Channel		13		mA
AD8331 (ENBL)			11		mA
AD8331 (ENBV)			14		mA
PSRR	$V_{GAIN} = 0, f = 100 \text{ kHz}$		-68		dB

AD8331/AD8332

ABSOLUTE MAXIMUM RATINGS

Table 2. Absolute Maximum Ratings

Parameter	Rating
Voltage	
Supply Voltage (VPSn, VPSV, VPSL, VPOS)	5.5 V
Input Voltage (INHn)	$V_S + 200 \text{ mV}$
ENB, ENBL, ENBV, HILO Voltage	$V_S + 200 \text{ mV}$
GAIN Voltage	2.5 V
Power Dissipation	
RU-28 Package (AD8332) ⁴	0.96 W
CP-32 Package (AD8332) ⁵	1.97 W
RQ-20 Package (AD8331) ⁴	0.78 W
Temperature	
Operating Temperature	-40°C to +85°C
Storage Temperature	-65°C to +150°C
Lead Temperature (Soldering 60 sec)	300°C
θ_{JA}	
RU-28 Package (AD8332) ⁴	68°C/W
CP-32 Package (AD8332) ⁵	33°C/W
RQ-20 Package (AD8331) ⁴	83°C/W
θ_{JC}	
RU-28 Package (AD8332) ⁴	14°C/W
CP-32 Package (AD8332) ⁵	33°C/W
RQ-20 Package (AD8331) ⁴	n/a

⁴ Four-Layer JEDEC Board (2S2P).

⁵ Exposed pad soldered to board, nine thermal vias in pad — JEDEC 4-Layer Board J-STD-51-9.

Stresses above those listed under the Absolute Maximum Ratings may cause permanent damage to the device. This is a stress rating only; functional operation of the device at these or any other conditions above those indicated in the operational section of this specification is not implied. Exposure to absolute maximum rating conditions for extended periods may affect device reliability.

ESD CAUTION

ESD (electrostatic discharge) sensitive device. Electrostatic charges as high as 4000 V readily accumulate on the human body and test equipment and can discharge without detection. Although this product features proprietary ESD protection circuitry, permanent damage may occur on devices subjected to high energy electrostatic discharges. Therefore, proper ESD precautions are recommended to avoid performance degradation or loss of functionality.



AD8331, AD8332—TYPICAL PERFORMANCE CHARACTERISTICS

$T_A = 25^\circ\text{C}$, $V_S = 5\text{ V}$, $R_L = 500\ \Omega$, $R_S = R_{IN} = 50\ \Omega$, $R_{FB} = 280\ \Omega$, $C_{SH} = 22\ \text{pF}$, $f = 10\ \text{MHz}$, $R_{CLMP} = \infty$, $C_L = 1\ \text{pF}$, $V_{CM} = 2.5\ \text{V}$, $-4.5\ \text{dB}$ to $+43.5\ \text{dB}$ gain (HILO = LO), and differential signal voltage, unless otherwise specified.

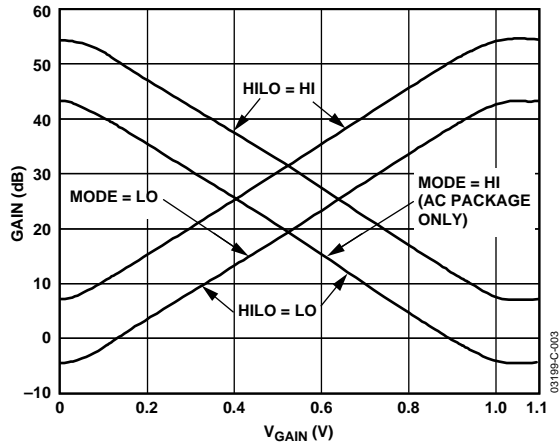

Figure 3. Gain vs. V_{GAIN} and MODE (MODE Available on AC Package)

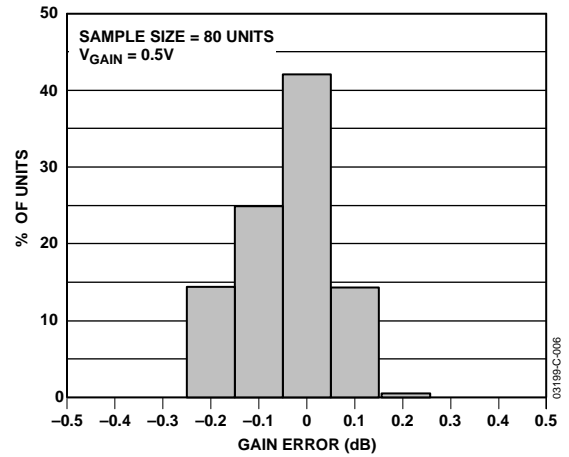

Figure 6. Gain Error Histogram

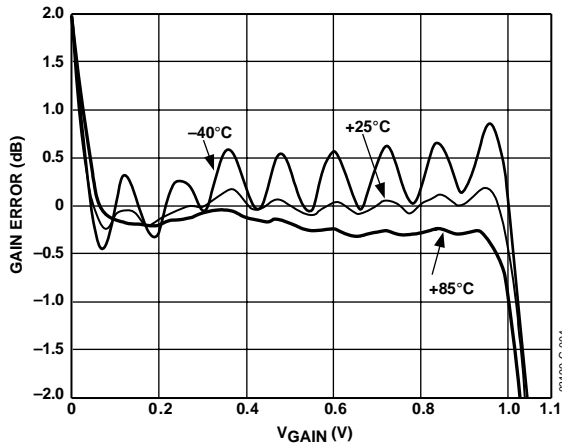

Figure 4. Absolute Gain Error vs. V_{GAIN} at Three Temperatures

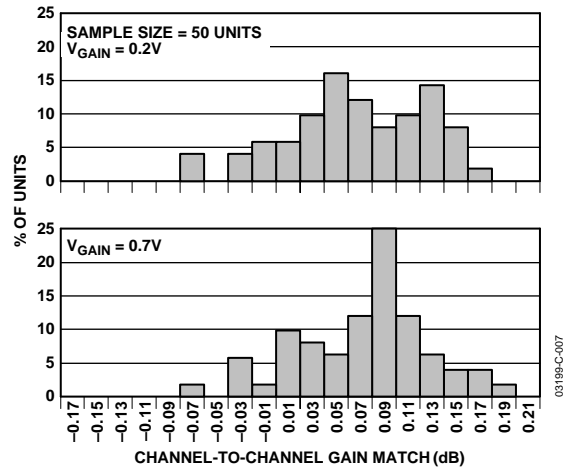

Figure 7. Gain Match Histogram for $V_{GAIN} = 0.2\text{ V}$ and 0.7 V

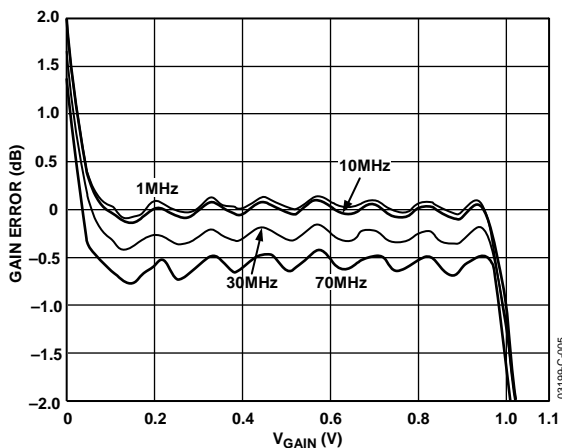

Figure 5. Absolute Gain Error vs. V_{GAIN} at Various Frequencies

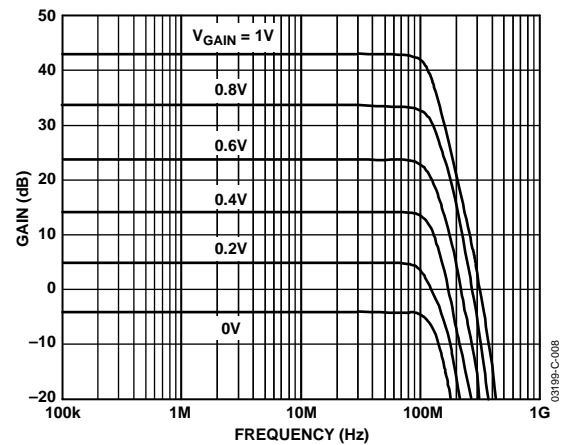

Figure 8. Frequency Response for Various Values of V_{GAIN}

AD8331/AD8332

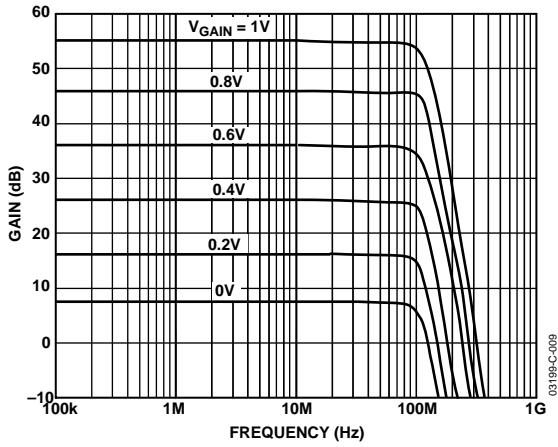

Figure 9. Frequency Response for Various Values of V_{GAIN} , HILO = HI

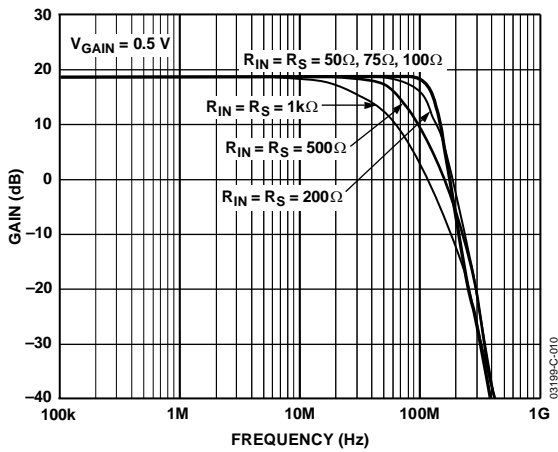

Figure 10. Frequency Response for Various Matched Source Impedances

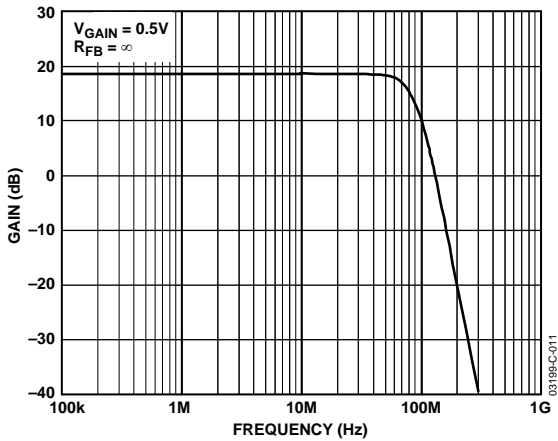

Figure 11. Frequency Response, Underterminated, $R_S = 50\Omega$

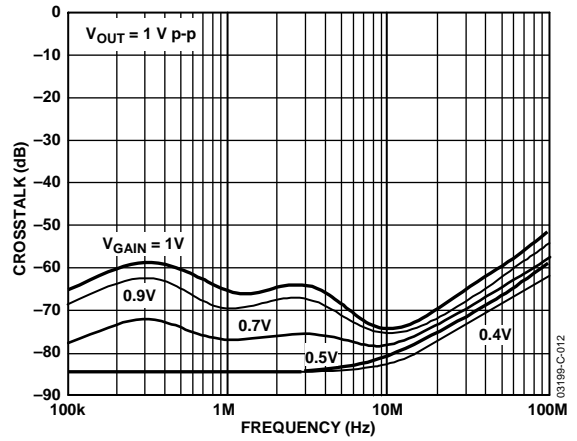

Figure 12. Channel-to-Channel Crosstalk vs. Frequency for Various Values of V_{GAIN}

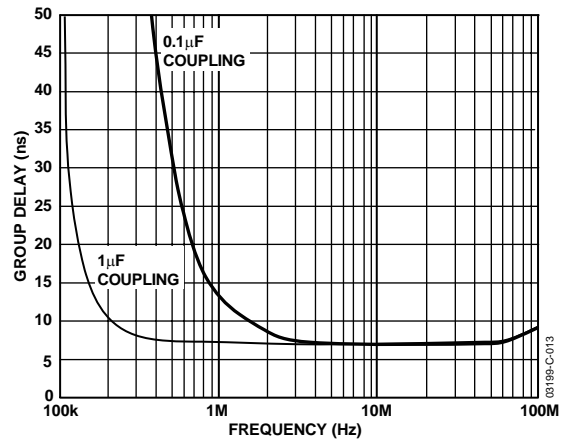

Figure 13. Group Delay vs. Frequency

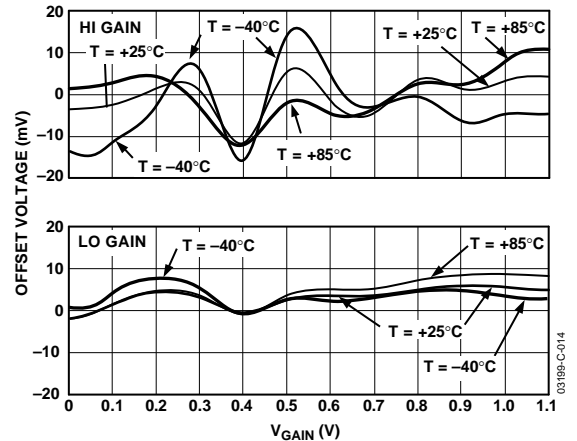

Figure 14. Representative Differential Output Offset Voltage vs. V_{GAIN} at Three Temperatures

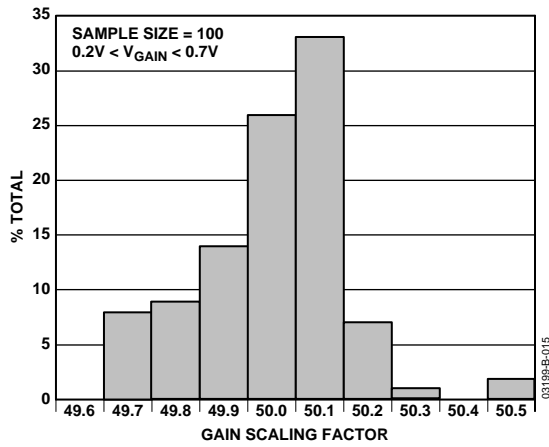

Figure 15. Gain Scaling Factor Histogram

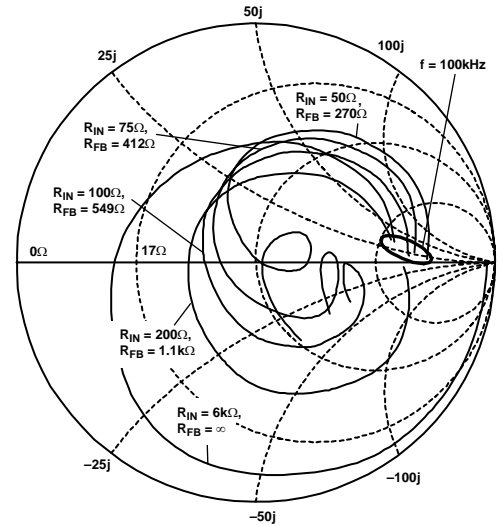

Figure 18. Smith Chart, S11 vs. Frequency, 0.1 MHz to 200 MHz for Various Values of R_{FB}

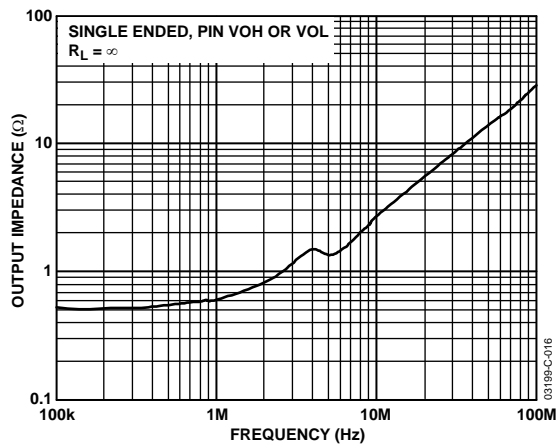

Figure 16. Output Impedance vs. Frequency

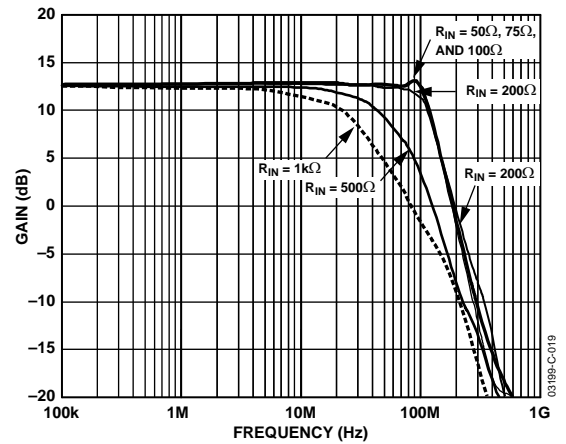

Figure 19. LNA Frequency Response, Single-Ended, for Various Values of R_{IN}

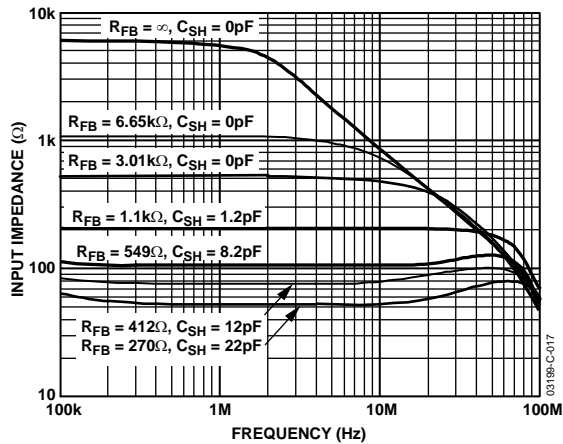

Figure 17. LNA Input Impedance vs. Frequency for Various Values of R_{FB} and C_{SH}

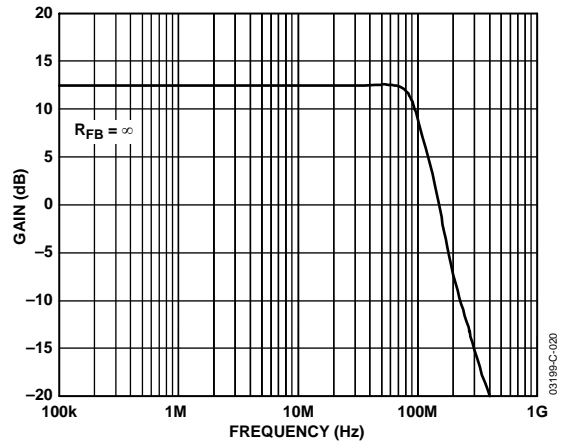

Figure 20. LNA Frequency Response, Underterminated, Single-Ended

AD8331/AD8332

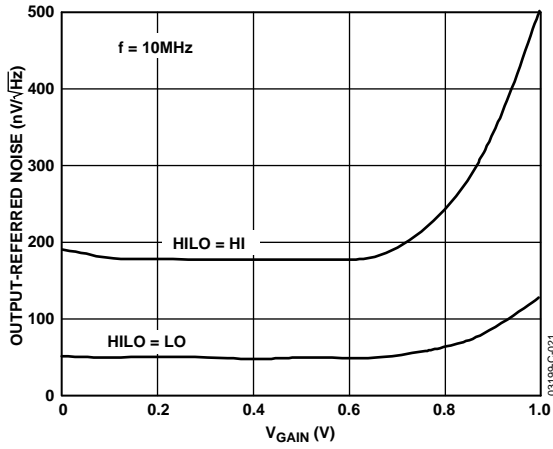

Figure 21. Output-Referred Noise vs. V_{GAIN}

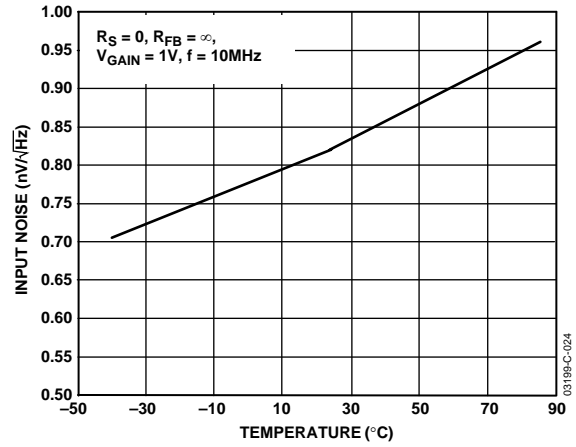

Figure 24. Short-Circuit Input-Referred Noise vs. Temperature

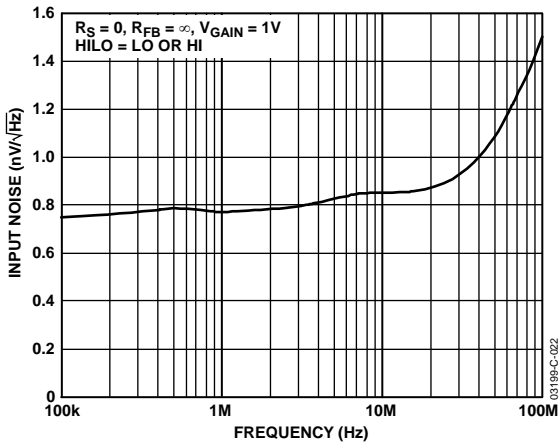

Figure 22. Short-Circuit Input-Referred Noise vs. Frequency

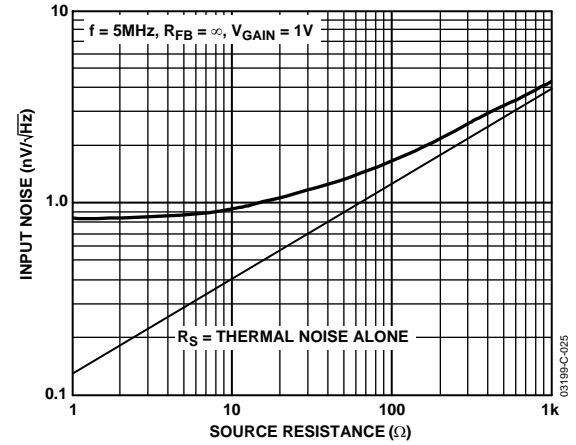

Figure 25. Input-Referred Noise vs. R_S

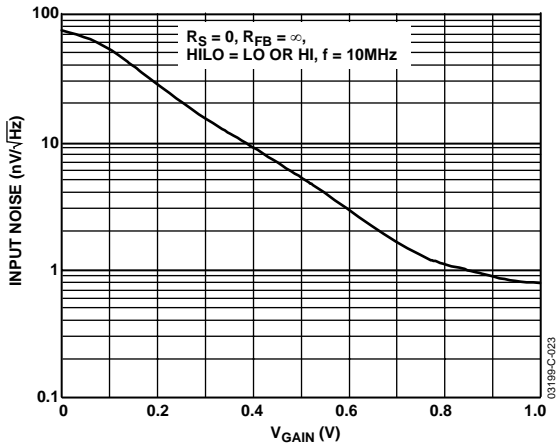

Figure 23. Short-Circuit Input-Referred Noise vs. V_{GAIN}

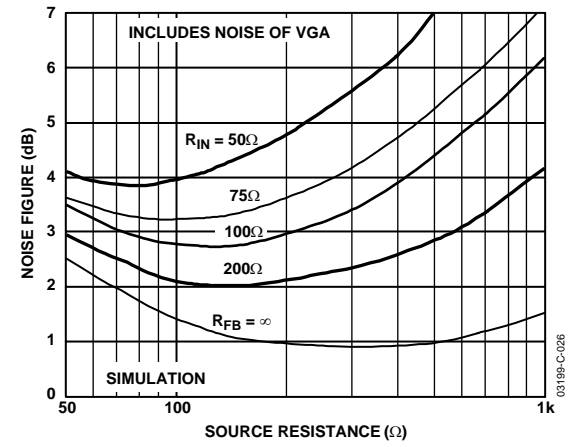

Figure 26. Noise Figure vs. R_S for Various Values of R_{IN}

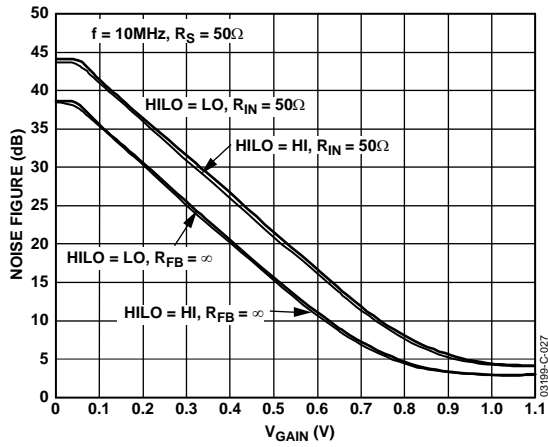

Figure 27. Noise Figure vs. V_{GAIN}

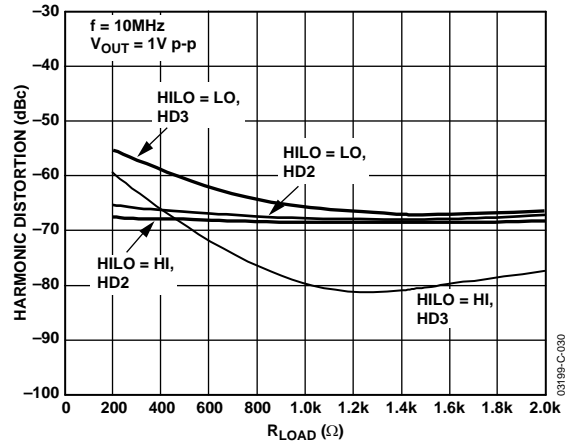

Figure 30. Harmonic Distortion vs. R_{LOAD}

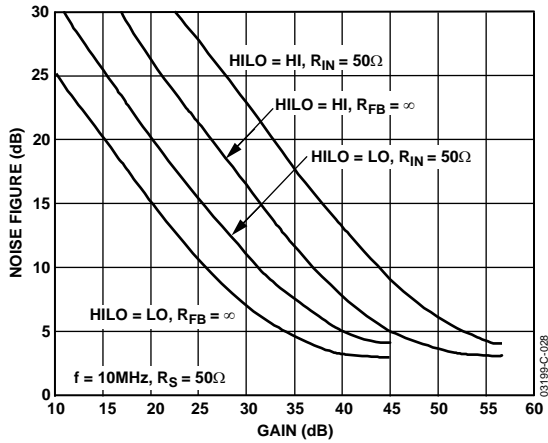

Figure 28. Noise Figure vs. Gain

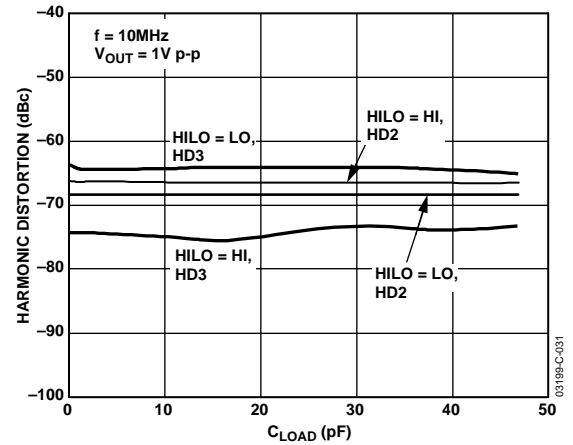

Figure 31. Harmonic Distortion vs. C_{LOAD}

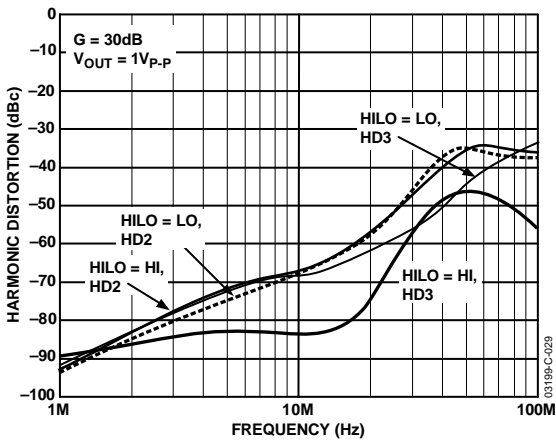

Figure 29. Harmonic Distortion vs. Frequency

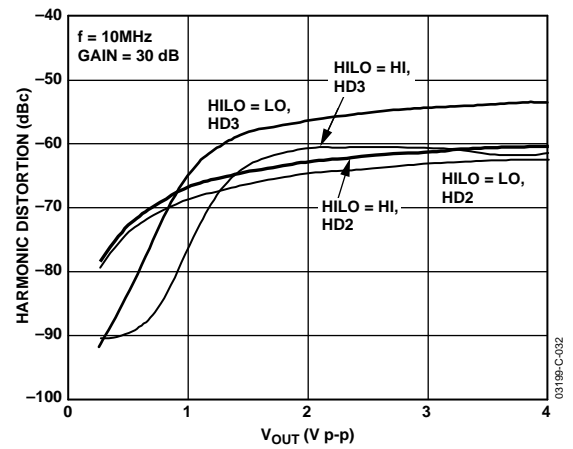

Figure 32. Harmonic Distortion vs. Differential Output Voltage

AD8331/AD8332

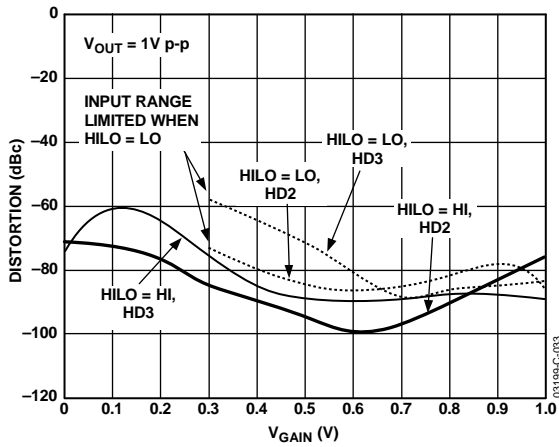

Figure 33. Harmonic Distortion vs. V_GAIN, f = 1 MHz

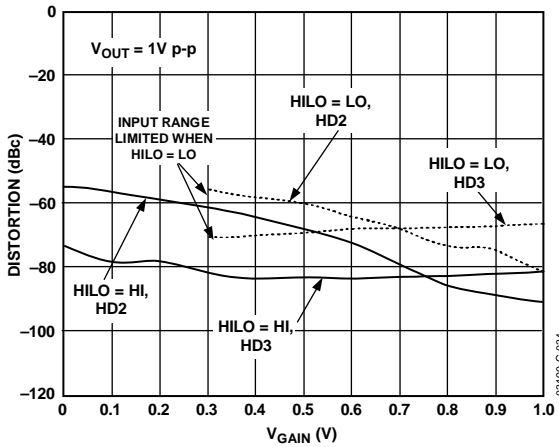

Figure 34. Harmonic Distortion vs. V_GAIN, f = 10 MHz

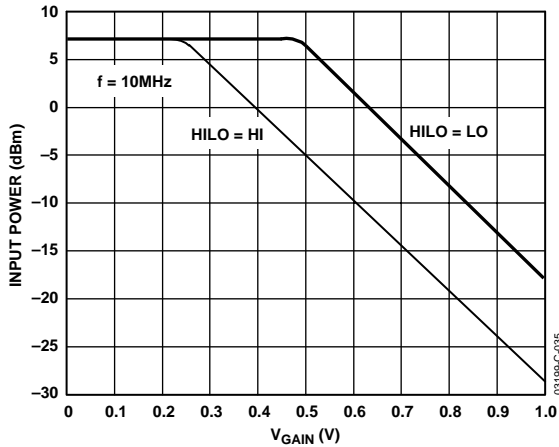

Figure 35. Input 1 dB Compression vs. V_GAIN

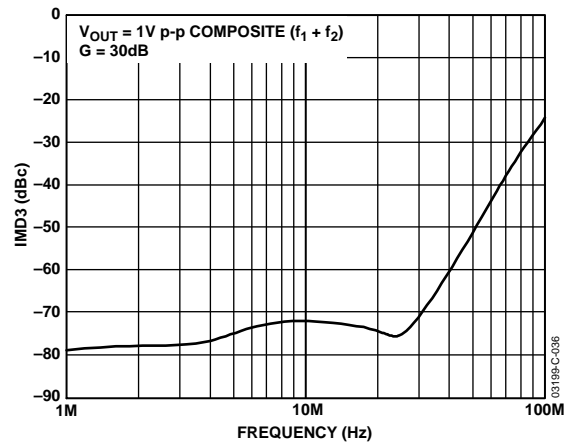

Figure 36. IMD3 vs. Frequency

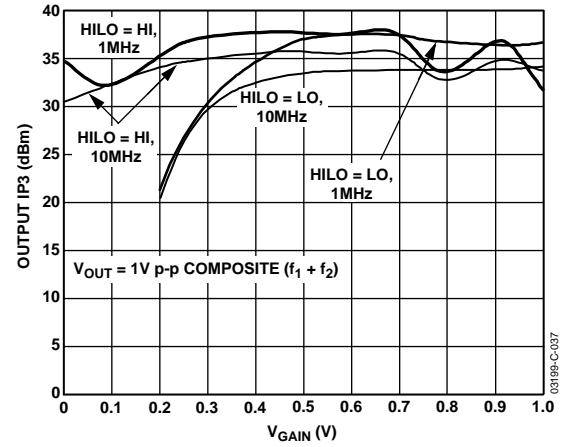

Figure 37. Output Third Order Intercept vs. V_GAIN

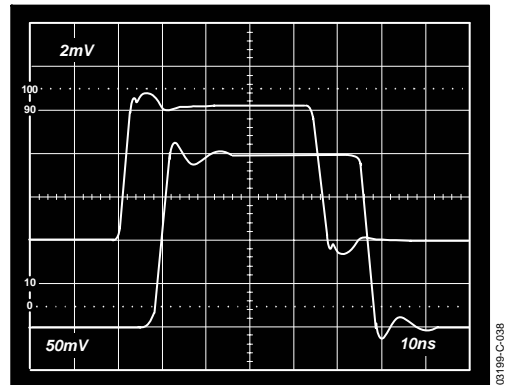

Figure 38. Small Signal Pulse Response, G = 30 dB, Top: Input, Bottom: Output Voltage, HILO = HI or LO

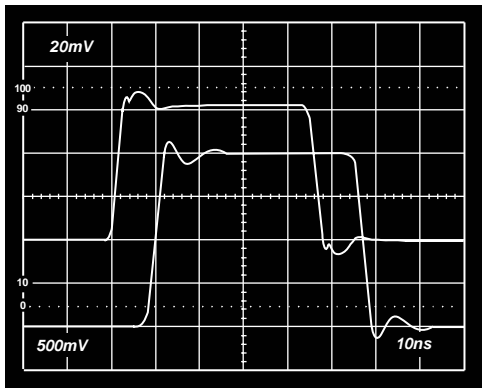

Figure 39. Large Signal Pulse Response, $G = 30$ dB, HILO = HI or LO, Top: Input, Bottom: Output Voltage

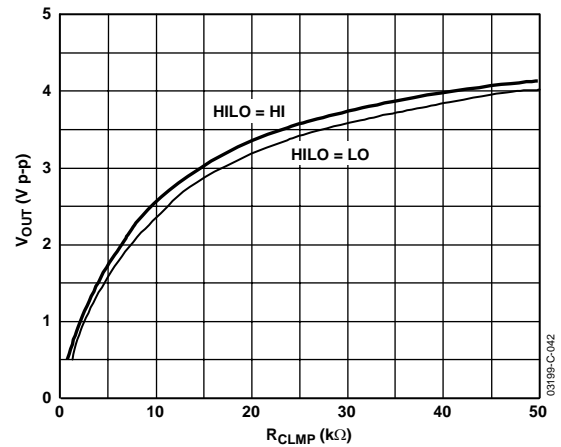

Figure 42. Clamp Level vs. R_{CLMP}

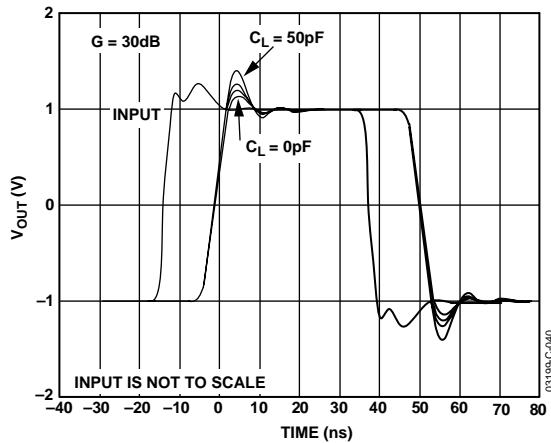

Figure 40. Large Signal Pulse Response for Various Capacitive Loads, $C_L = 0$ pF, 10 pF, 20 pF, 50 pF

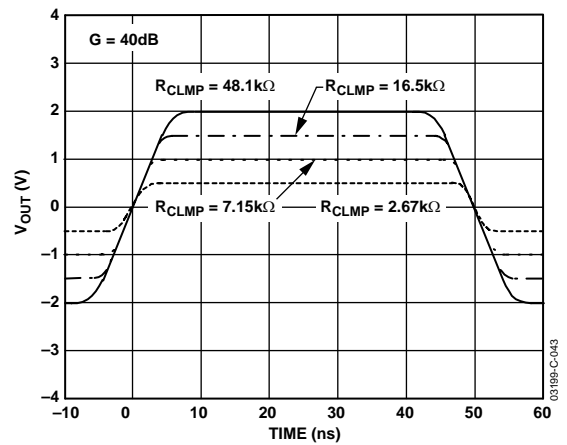

Figure 43. Clamp Level Pulse Response

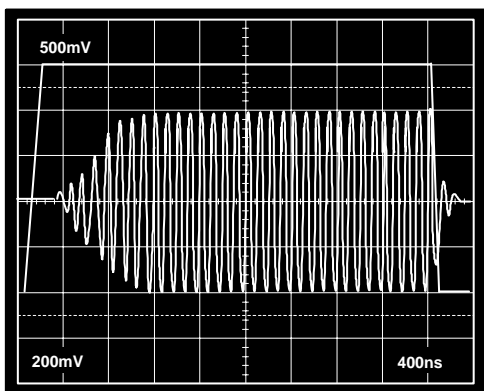

Figure 41. Pin GAIN Transient Response, Top: V_{GAIN} , Bottom: Output Voltage

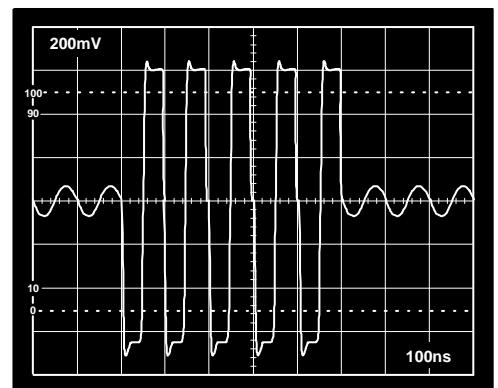

Figure 44. LNA Overdrive Recovery, $V_{INH} 0.05$ V p-p to 1 V p-p Burst, $V_{GAIN} = 0.27$ V, VGA Output Shown

AD8331/AD8332

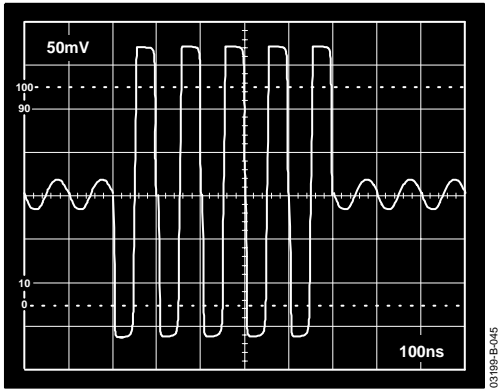

Figure 45. VGA Overdrive Recovery, V_{INH} 4 mV p-p to 70 mV p-p Burst, $V_{GAIN} = 1$ V, VGA Output Shown Attenuated 24 dB

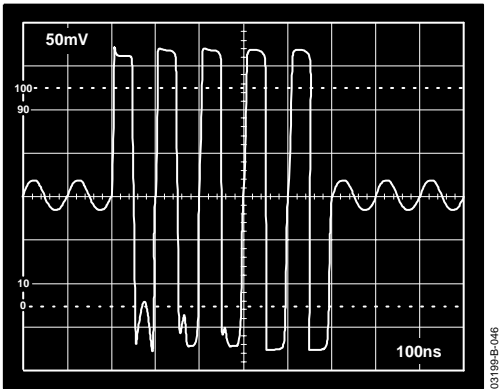

Figure 46. VGA Overdrive Recovery, V_{INH} 4 mV p-p to 275 mV p-p Burst, $V_{GAIN} = 1$ V, VGA Output Shown Attenuated 24 dB

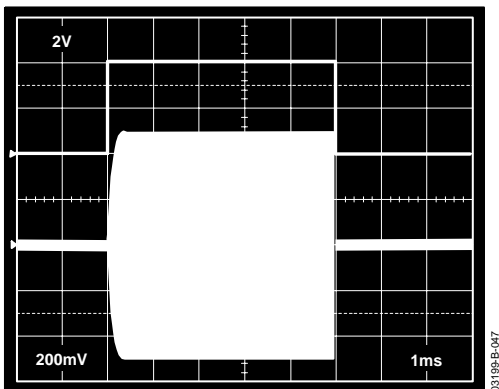

Figure 47. Enable Response, Top: V_{ENB} , Bottom: V_{OUT} , $V_{INH} = 30$ mV p-p

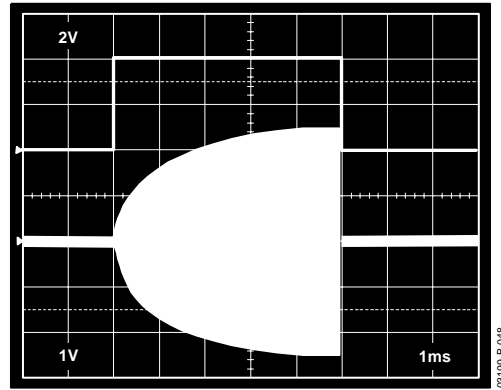

Figure 48. Enable Response, Large Signal, Top: V_{ENB} , Bottom: V_{OUT} , $V_{INH} = 150$ mV p-p

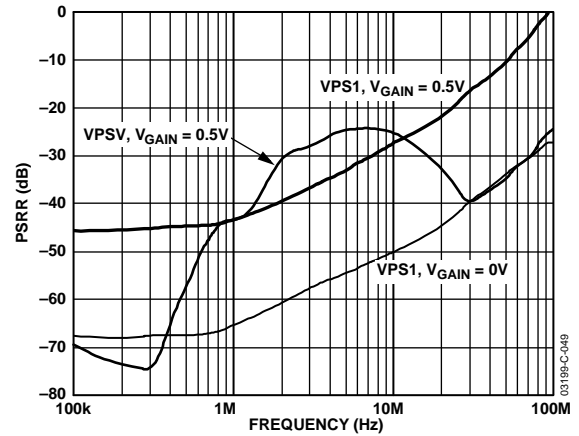

Figure 49. PSRR vs. Frequency (No Bypass Capacitor)

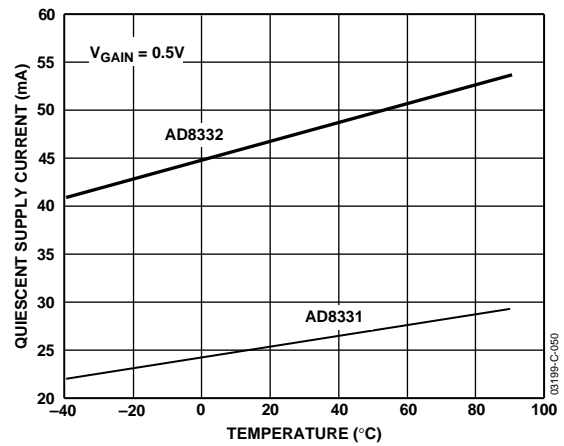

Figure 50. Quiescent Supply Current vs. Temperature

TEST CIRCUITS

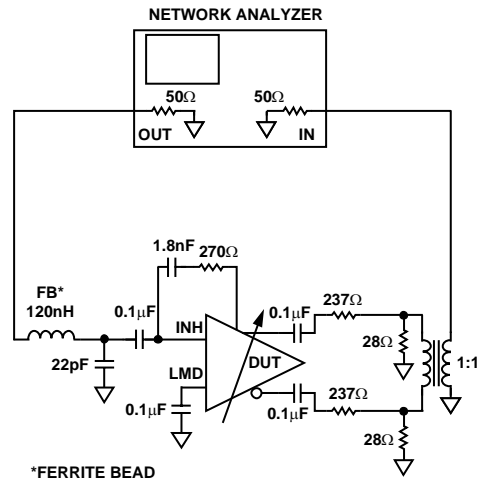

Figure 51. Gain and Bandwidth Measurements

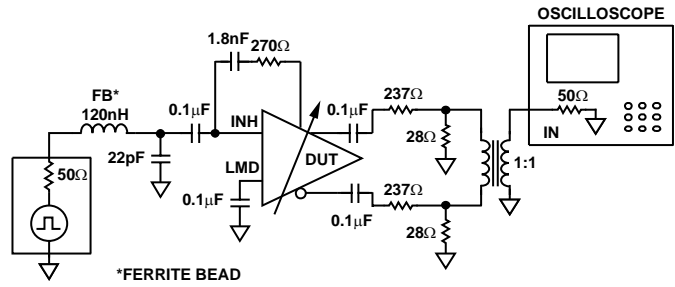

Figure 52. Transient Measurements

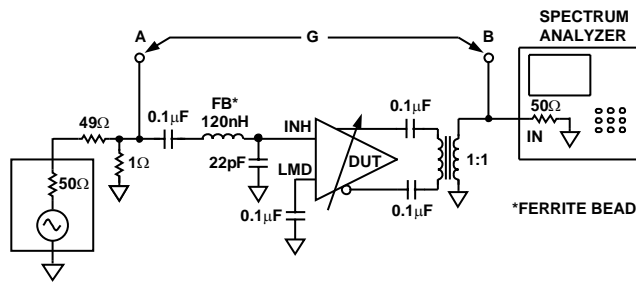

Figure 53. Used for Noise Measurements

AD8331/AD8332

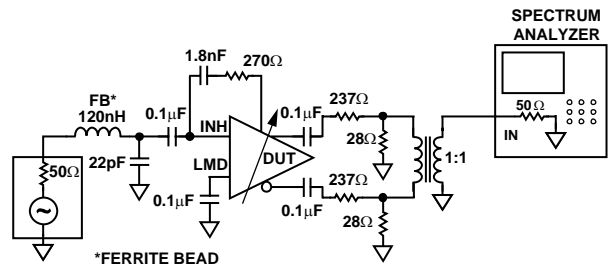

Figure 54. Distortion

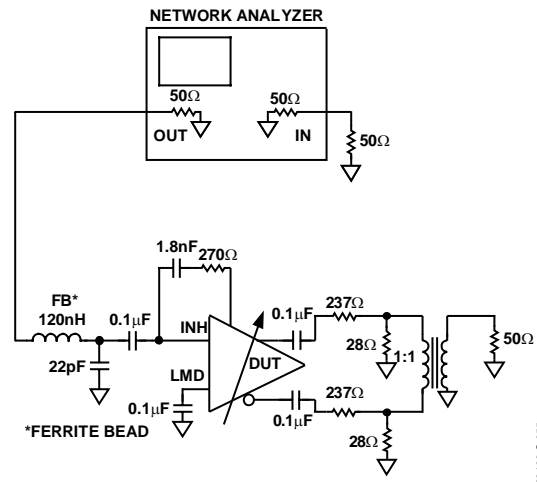

Figure 55. S11 Measurements

THEORY OF OPERATION

OVERVIEW

The following discussion applies to all part numbers. Figure 56 and Figure 1 are functional block diagrams of the AD8331 and AD8332, respectively.

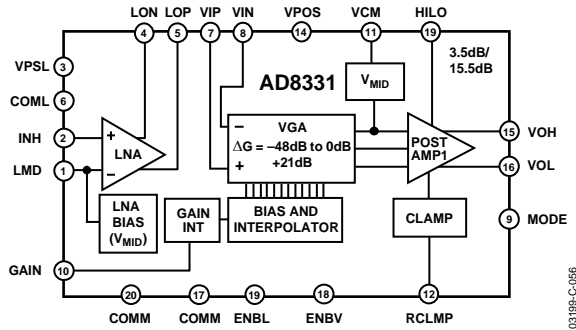

Figure 56. Functional Block Diagram — AD8331

Each channel contains an LNA that provides user-adjustable input impedance termination, a differential X-AMP VGA, and a programmable gain postamplifier with adjustable output voltage limiting. Figure 57 shows a simplified block diagram.

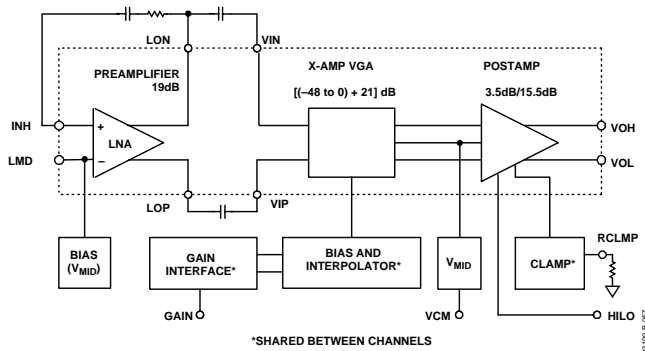

Figure 57. Simplified Block Diagram

The linear-in-dB gain control interface is trimmed for slope and absolute accuracy. The overall gain range is 48 dB, extending from -4.5 dB to +43.5 dB or from +7.5 dB to +55.5 dB, depending on the setting of the HILO pin. The slope of the gain control interface is 50 dB/V, and the gain control range is 40 mV to 1 V, leading to the following expressions for gain:

$$GAIN(dB) = 50(dB/V) \times V_{GAIN} - 6.5 dB, (HILO = LO) \quad (1)$$

or

$$GAIN(dB) = 50(dB/V) \times V_{GAIN} + 5.5 dB, (HILO = HI) \quad (2)$$

The gain characteristics are shown in Figure 58.

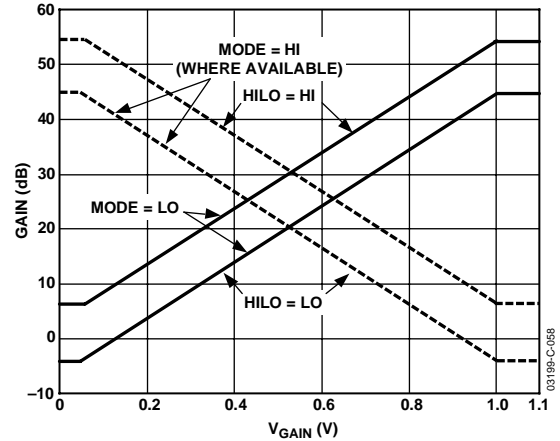

Figure 58. Gain Control Characteristics

When MODE is set high, (where available):

$$GAIN(dB) = -50(dB/V) \times V_{GAIN} + 45.5 dB, (HILO = LO) \quad (3)$$

or

$$GAIN(dB) = -50(dB/V) \times V_{GAIN} + 57.5 dB, (HILO = HI) \quad (4)$$

The LNA converts a single-ended input to a differential output with a voltage gain of 19 dB. When only one output is used, the gain is 13 dB. The inverting output is used for active input impedance termination. Each of the LNA outputs is capacitively coupled to a VGA input. The VGA consists of an attenuator with a range of 48 dB followed by an amplifier with 21 dB of gain, for a net gain range of -27 dB to +21 dB. The X-AMP gain-interpolation technique results in low gain error and uniform bandwidth, and differential signal paths minimize distortion.

The final stage is a logic programmable amplifier with gains of 3.5 dB or 15.5 dB. The LO and HI gain modes are optimized for 12-bit and 10-bit A/D converter applications, in terms of output-referred noise and absolute gain range. Output voltage limiting may be programmed by the user.

LOW NOISE AMPLIFIER (LNA)

Good noise performance relies on a proprietary ultralow noise preamplifier at the beginning of the signal chain, which minimizes the noise contribution in the following VGA. Active impedance control optimizes noise performance for applications that benefit from input matching.

AD8331/AD8332

A simplified schematic of the LNA is shown in Figure 59. INH is capacitively coupled to the source. An on-chip bias generator centers the output dc levels at 2.5 V and the input voltages at 3.25 V. A capacitor C_{LMD} of the same value as the input coupling capacitor C_{INH} is connected from the LMD pin to ground.

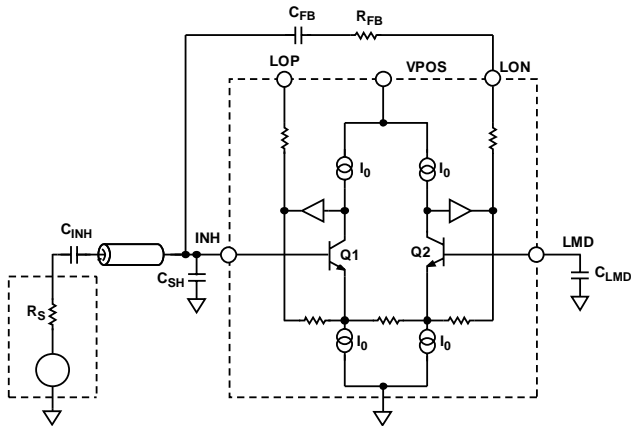

Figure 59. Simplified LNA Schematic

The LNA supports differential output voltages as high as 5 V p-p with positive and negative excursions of ± 1.25 V, about a common-mode voltage of 2.5 V. Since the differential gain magnitude is 9, the maximum input signal before saturation is ± 275 mV or 550 mV p-p. Overload protection ensures quick recovery time from large input voltages. Since the inputs are capacitively coupled to a bias voltage near midsupply, very large inputs can be handled without interacting with the ESD protection.

Low value feedback resistors and the current-driving capability of the output stage allow the LNA to achieve a low input-referred voltage noise of 0.74 nV/ $\sqrt{\text{Hz}}$. This is achieved with a modest current consumption of 10 mA per channel (50 mW). On-chip resistor matching results in precise gains of 4.5 per side (9 differential), critical for accurate impedance control. The use of a fully differential topology and negative feedback minimizes distortion. Low HD2 is particularly important in second harmonic ultrasound imaging applications. Differential signaling enables smaller swings at each output, further reducing third order distortion.

Active Impedance Matching

The LNA supports active impedance matching through an external shunt feedback resistor from Pin LON to Pin INH. The input resistance R_{IN} is given by Equation 5, where A is the single-ended gain of 4.5, and 6 k Ω is the unterminated input impedance.

$$R_{IN} = \frac{R_{FB}}{1 + A} \parallel 6 \text{ k}\Omega = \frac{6 \text{ k}\Omega \times R_{FB}}{33 \text{ k}\Omega + R_{FB}} \quad (5)$$

C_{FB} is needed in series with R_{FB} , since the dc levels at Pins LON and INH are unequal. Expressions for choosing R_{FB} in terms of R_{IN} and for choosing C_{FB} are found in the Applications section. C_{SH} and the ferrite bead enhance stability at higher frequencies where the loop gain declines and prevents peaking. Frequency response plots of the LNA are shown in Figure 19 and Figure 20. The bandwidth is approximately 130 MHz for matched input impedances of 50 Ω to 200 Ω and declines at higher source impedances. The unterminated bandwidth ($R_{FB} = \infty$) is approximately 80 MHz.

Each output can drive external loads as low as 100 Ω in addition to the 100 Ω input impedance of the VGA (200 Ω differential). Capacitive loading up to 10 pF is permissible. All loads should be ac-coupled. Typically, Pin LOP output is used as a single-ended driver for auxiliary circuits, such as those used for Doppler mode ultrasound imaging, and Pin LON drives R_{FB} . Alternatively, a differential external circuit can be driven from the two outputs, in addition to the active feedback termination. In both cases, important stability considerations discussed in the Applications section should be carefully observed.

The impedance at each LNA output is 5 Ω . A 0.4 dB reduction in open-circuit gain results when driving the VGA, and 0.8 dB with an additional 100 Ω load at the output. The differential gain of the LNA is 6 dB higher. If the load is less than 200 Ω on either side, a compensating load is recommended on the opposite output.

LNA Noise

The input-referred voltage noise sets an important limit on system performance. The short-circuit input voltage noise of the LNA is 0.74 nV/ $\sqrt{\text{Hz}}$ or 0.82 nV/ $\sqrt{\text{Hz}}$ (at maximum gain), including the VGA noise. The open-circuit current noise is 2.5 pA/ $\sqrt{\text{Hz}}$. These measurements, taken without a feedback resistor, provide the basis for calculating the input noise and noise figure performance of the configurations in Figure 60. Figure 61 and Figure 62 are simulations extracted from these results, and the 4.1 dB NF measurement with the input actively matched to a 50 Ω source. Unterminated ($R_{FB} = \infty$) operation exhibits the lowest equivalent input noise and noise figure. Figure 61 shows the noise figure versus source resistance, rising at low R_S , where the LNA voltage noise is large compared to the source noise, and again at high R_S due to current noise. The VGA's input-referred voltage noise of 2.7 nV/ $\sqrt{\text{Hz}}$ is included in all of the curves.

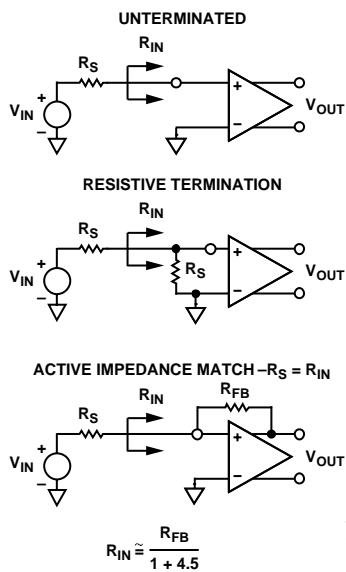

Figure 60. Input Configurations

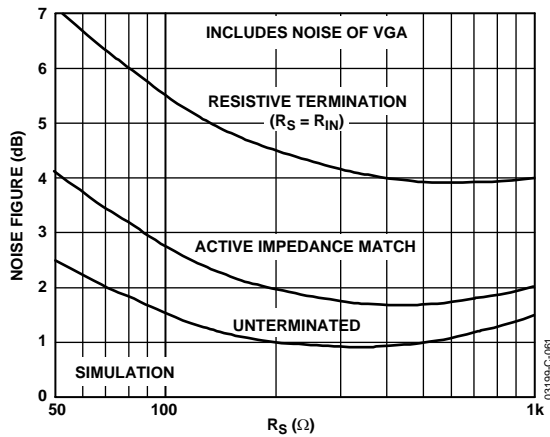

Figure 61. Noise Figure vs. R_S for Resistive, Active Matched, and Underterminated Inputs

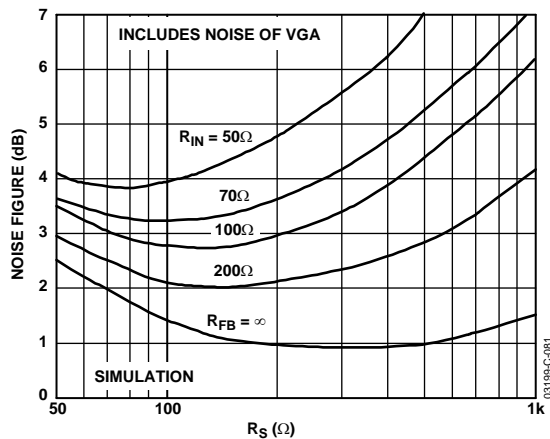

Figure 62. Noise Figure vs. R_S for Various Fixed Values of R_{IN} , Actively Matched

The primary purpose of input impedance matching is to improve the system transient response. With resistive termination, the input noise increases due to the thermal noise of the matching resistor and the increased contribution of the LNA's input voltage noise generator. With active impedance matching, however, the contributions of both are smaller than they would be for resistive termination by a factor of $1/(1 + LNA\ Gain)$. Figure 61 shows their relative noise figure (NF) performance. In this graph, the input impedance has been swept with R_S to preserve the match at each point. The noise figures for a source impedance of $50\ \Omega$ are 7.1 dB, 4.1 dB, and 2.5 dB, respectively, for the resistive, active, and unterminated configurations. The noise figures for $200\ \Omega$ are 4.6 dB, 2.0 dB, and 1.0 dB, respectively.

Figure 62 is a plot of the NF versus R_S for various values of R_{IN} , which is helpful for design purposes. The plateau in the NF for actively matched inputs mitigates source impedance variations. For comparison purposes, a preamp with a gain of 19 dB and noise spectral density of a $1.0\ nV/\sqrt{Hz}$, combined with a VGA with $3.75\ nV/\sqrt{Hz}$, would yield a noise figure degradation of approximately 1.5 dB (for most input impedances), significantly worse than the AD8332 performance.

The equivalent input noise of the LNA is the same for single-ended and differential output applications. The LNA noise figure improves to 3.5 dB at $50\ \Omega$ without VGA noise, but this is exclusive of noise contributions from other external circuits connected to LOP. A series output resistor is usually recommended for stability purposes, when driving external circuits on a separate board (see the Applications section). In low noise applications, a ferrite bead is even more desirable.

VARIABLE GAIN AMPLIFIER

The differential X-AMP VGA provides precise input attenuation and interpolation. It has a low input-referred noise of $2.7\ nV/\sqrt{Hz}$ and excellent gain linearity. A simplified block diagram is shown in Figure 63.

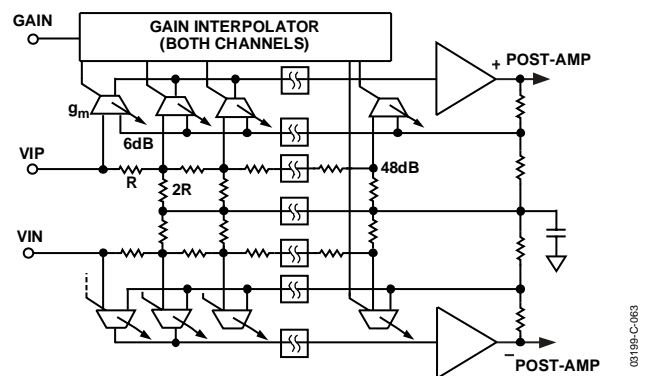

Figure 63. Simplified VGA Schematic

AD8331/AD8332

X-AMP VGA

The input of the VGA is a differential R-2R ladder attenuator network, with 6 dB steps per stage and a net input impedance of 200 Ω differential. The ladder is driven by a fully differential input signal from the LNA and is not intended for single-ended operation. LNA outputs are ac-coupled to reduce offset and isolate their common-mode voltage. The VGA inputs are biased through the ladder's center tap connection to VCM, which is typically set to 2.5 V and is bypassed externally to provide a clean ac ground.

The signal level at successive stages in the input attenuator falls from 0 dB to -48 dB, in 6 dB steps. The input stages of the X-AMP are distributed along the ladder, and a biasing interpolator, controlled by the gain interface, determines the input tap point. With overlapping bias currents, signals from successive taps merge to provide a smooth attenuation range from 0 dB to -48 dB. This circuit technique results in excellent, linear-in-dB gain law conformance and low distortion levels and deviates ± 0.2 dB or less from ideal. The gain slope is monotonic with respect to the control voltage and is stable with variations in process, temperature, and supply.

The X-AMP inputs are part of a gain-of-12 feedback amplifier, which completes the VGA. Its bandwidth is 150 MHz. The input stage is designed to reduce feedthrough to the output and ensure excellent frequency response uniformity across gain setting (see Figure 8 and Figure 9).

Gain Control

Position along the VGA attenuator is controlled by a single-ended analog control voltage, V_{GAIN} , with an input range of 40 mV to 1.0 V. The gain control scaling is trimmed to a slope of 50 dB/V (20 mV/dB). Values of V_{GAIN} beyond the control range saturate to minimum or maximum gain values. Both channels of the AD8332 are controlled from a single gain interface to preserve matching. Gain can be calculated using Equations 1 and 2.

Gain accuracy is very good since both the scaling factor and absolute gain are factory trimmed. The overall accuracy relative to the theoretical gain expression is ± 1 dB for variations in temperature, process, supply voltage, interpolator gain ripple, trim errors, and tester limits. The gain error relative to a best-fit line for a given set of conditions is typically ± 0.2 dB. Gain matching between channels is better than 0.1 dB (see Figure 7, which shows gain errors in the center of the control range). When $V_{\text{GAIN}} < 0.1$ or > 0.95 , gain errors are slightly greater.

The gain slope may be inverted, as shown in Figure 58 (available in most versions). The gain drops with a slope of -50 dB/V across the gain control range from maximum to minimum gain. This slope is useful in applications, such as automatic gain control, where the control voltage is proportional to the measured output signal amplitude. The inverse gain mode is selected by setting the MODE pin HI.

Gain control response time is less than 750 ns to settle within 10% of the final value for a change from minimum to maximum gain.

VGA Noise

In a typical application, a VGA compresses a wide dynamic range input signal to within the input span of an ADC. While the input-referred noise of the LNA limits the minimum resolvable input signal, the output-referred noise, which depends primarily on the VGA, limits the maximum instantaneous dynamic range that can be processed at any one particular gain control voltage. This limit is set in accordance with the quantization noise floor of the ADC.

Output and input-referred noise as a function of V_{GAIN} are plotted in Figure 21 and Figure 23 for the short-circuited input condition. The input noise voltage is simply equal to the output noise divided by the measured gain at each point in the control range.

The output-referred noise is flat over most of the gain range, since it is dominated by the fixed output-referred noise of the VGA. Values are 48 nV/ $\sqrt{\text{Hz}}$ in LO gain mode and 178 nV/ $\sqrt{\text{Hz}}$ in HI gain mode. At the high end of the gain control range, the noise of the LNA and source prevail. The input-referred noise reaches its minimum value near the maximum gain control voltage, where the input-referred contribution of the VGA becomes very small.

At lower gains, the input-referred noise, and thus noise figure, increases as the gain decreases. The instantaneous dynamic range of the system is not lost, however, since the input capacity increases with it. The contribution of the ADC noise floor has the same dependence as well. The important relationship is the magnitude of the VGA output noise floor relative to that of the ADC.

With its low output-referred noise levels, these devices ideally drive low-voltage ADCs. The converter noise floor drops 12 dB for every 2 bits of resolution and drops at lower input full-scale voltages and higher sampling rates. ADC quantization noise is discussed in the Applications section.

The preceding noise performance discussion applies to a differential VGA output signal. Although the LNA noise performance is the same in single-ended and differential applications, the VGA performance is not. The noise of the VGA is significantly higher in single-ended usage, since the contribution of its bias noise is designed to cancel in the differential signal. A transformer can be used with single-ended applications when low noise is desired.

Gain control noise is a concern in very low noise applications. Thermal noise in the gain control interface can modulate the channel gain. The resultant noise is proportional to the output signal level and usually only evident when a large signal is present. Its effect is observable only in LO gain mode, where the noise floor is substantially lower. The gain interface includes an on-chip noise filter, which reduces this effect significantly at frequencies above 5 MHz. Care should be taken to minimize noise impinging at the GAIN input. An external RC filter may be used to remove V_{GAIN} source noise. The filter bandwidth should be sufficient to accommodate the desired control bandwidth.

Common-Mode Biasing

An internal bias network connected to a midsupply voltage establishes common-mode voltages in the VGA and postamp. An externally bypassed buffer maintains the voltage. The bypass capacitors form an important ac ground connection, since the VCM network makes a number of important connections internally, including the center tap of the VGA's differential input attenuator, the feedback network of the VGA's fixed gain amplifier, and the feedback network of the postamplifier in both gain settings. For best results, use a 1 nF and a 0.1 μF capacitor in parallel, with the 1 nF nearest to Pin VCM. Separate VCM pins are provided for each channel. For dc-coupling to a 3 V ADC, the output common-mode voltage is adjusted to 1.5 V by biasing the VCM pin.

POSTAMPLIFIER

The final stage has a selectable gain of 3.5 dB or 15.5 dB, set by the logic Pin HILO. These correspond to linear gains of 1.5 or 6. A simplified block diagram of the postamplifier is shown in Figure 64.

Separate feedback attenuators implement the two gain settings. These are selected in conjunction with an appropriately scaled input stage to maintain a constant 3 dB bandwidth between the two gain modes (~ 150 MHz). The slew rate is 1200 V/ μs in HI gain mode and 300 V/ μs in LO gain mode. The feedback networks for HI and LO gain modes are factory trimmed to adjust the absolute gains of each channel.

Noise

The topology of the postamplifier provides constant input-referred noise with the two gain settings and variable output-referred noise. The output-referred noise in HI gain mode increases (with gain) by four. This setting is recommended when driving converters with higher noise floors. The extra gain boosts the output signal levels and noise floor appropriately. When driving circuits with lower input noise floors, the LO gain mode optimizes the output dynamic range.

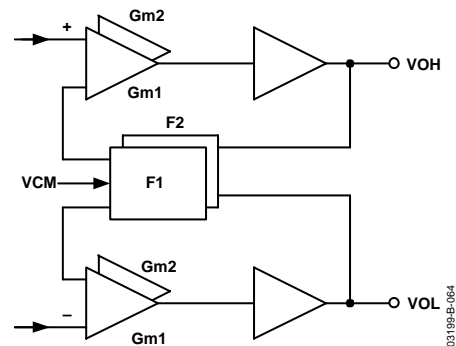

Figure 64. Postamplifier Block Diagram

Although the quantization noise floor of an ADC depends on a number of factors, the 48 nV/ $\sqrt{\text{Hz}}$ and 178 nV/ $\sqrt{\text{Hz}}$ levels are well suited to the average requirements of most 12-bit and 10-bit converters, respectively. An additional technique, described in the Applications section, can extend the noise floor even lower for possible use with 14-bit ADCs.

Output Clamping

Outputs are internally limited to a level of 4.5 V p-p differential when operating at a 2.5 V common-mode voltage. The postamp implements an optional output clamp engaged through a resistor from R_{CLMP} to ground. Table shows a list of recommended resistor values.

Output clamping can be used for ADC input overload protection, if needed, or postamp overload protection when operating from a lower common-mode level, such as 1.5 V. The user should be aware that distortion products increase as output levels approach the clamping levels and should adjust the clamp resistor accordingly. Also, see the Applications section.

The accuracy of the clamping levels is approximately $\pm 5\%$ in LO or HI mode. Figure 65 illustrates the output characteristics for a few values of R_{CLMP} .

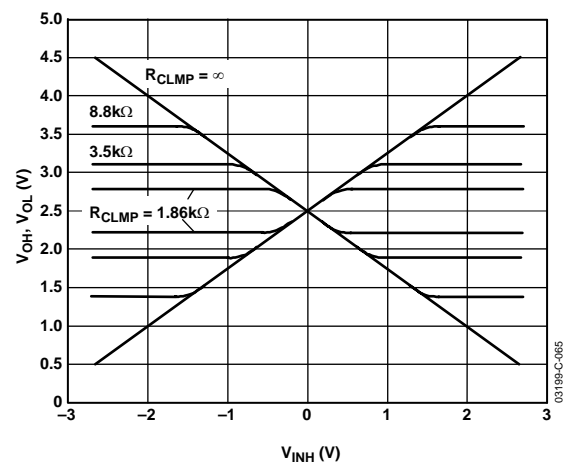

Figure 65. Output Clamping Characteristics

AD8331/AD8332

APPLICATIONS

LNA – EXTERNAL COMPONENTS

The LMD pin (connected to the bias circuitry) must be bypassed to ground, and signal source to the INH pin capacitively coupled using 2.2 nF to 0.1 μF capacitors (see Figure 66).

The unterminated input impedance of the LNA is 6 kΩ. The user may synthesize any LNA input resistance between 50 Ω and 6 kΩ. R_{FB} is calculated according to Equation 6 or selected from Table .

$$R_{FB} = \frac{33 \text{ k}\Omega \times (R_{IN})}{6 \text{ k}\Omega - (R_{IN})} \quad (6)$$

Table 3. LNA External Component Values for Common Source Impedances

R_{IN} (Ω)	R_{FB} (Nearest STD 1% Value, Ω)	C_{SH} (pF)
50	280	22
75	412	12
100	562	8
200	1.13k	1.2
500	3.01k	None
6k	∞	None

When active input termination is used, a 0.1 μF capacitor (C_{FB}) is required to isolate the input and output bias voltages of the LNA.

The shunt input capacitor, C_{SH} , reduces gain peaking at higher frequencies where the active termination match is lost due to the HF gain roll-off of the LNA. Suggested values are shown in Table ; for unterminated applications, reduce the capacitor value by half.

When a long trace to Pin INH is unavoidable, or if both LNA outputs drive external circuits, a small ferrite bead (FB) in series with Pin INH preserves circuit stability with negligible effect on noise. The bead shown is 75 Ω at 100 MHz (Murata BLM21 or equivalent). Other values may prove useful.

Figure 67 shows the interconnection details of the LNA output. Capacitive coupling between LNA outputs and the VGA inputs is required because of differences in their dc levels and to eliminate the offset of the LNA. Capacitor values of 0.1 μF are recommended. There is 0.4 dB loss in gain between the LNA output and the VGA input due to the 5 Ω output resistance. Additional loading at the LOP and LON outputs will affect LNA gain.

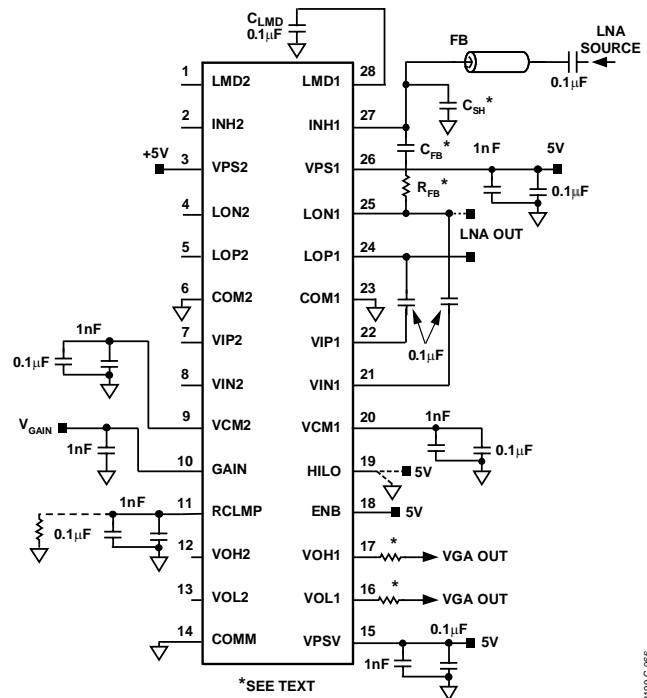

Figure 66. Basic Connections for a Typical Channel (AD8332 Shown)

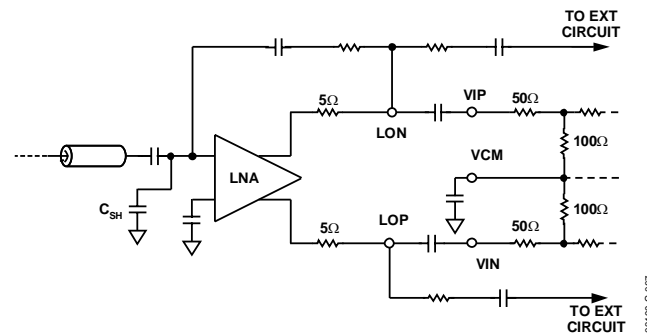

Figure 67. Interconnections of the LNA and VGA

Both LNA outputs are available for driving external circuits. Pin LOP should be used in those instances when a single-ended LNA output is required. The user should be aware of stray capacitance loading of the LNA outputs, in particular LON. The LNA can drive 100 Ω in parallel with 10 pF. If an LNA output is routed to a remote PC board, it will tolerate a load capacitance up to 100 pF with the addition of a 49.9 Ω series resistor or ferrite 75 Ω/100 MHz bead.

Gain Input

Pin GAIN is common to both channels of the AD8332. The input impedance is nominally 10 MΩ and a bypass capacitor from 100 pF to 1 nF is recommended.

Parallel connected devices may be driven by a common voltage source or DAC. Decoupling should take into account any bandwidth considerations of the drive waveform, using the total distributed capacitance.

If gain control noise in LO gain mode becomes a factor, maintaining ≤ 15 nV/√Hz noise at the GAIN pin will ensure satisfactory noise performance. Internal noise prevails below 15 nV/√Hz at the GAIN pin. Gain control noise is negligible in HI gain mode.

VCM Input

The common-mode voltage of Pins VCM, VOL, and VOH defaults to 2.5 Vdc. With output ac-coupled applications, the VCM pin will be unterminated; however, it must still be bypassed in close proximity for ac grounding of internal circuitry. The VGA outputs may be dc connected to a differential load, such as an ADC. Common-mode output voltage levels between 1.5 V and 3.5 V may be realized at Pins VOH and VOL by applying the desired voltage at Pin VCM. DC-coupled operation is not recommended when driving loads on a separate PC board.

The voltage on the VCM pin is sourced by an internal buffer with an output impedance of 30 Ω and a ± 2 mA default output current (see Figure 68). If the VCM pin is driven from an external source, its output impedance should be $\ll 30$ Ω and its current drive capability should be $\gg 2$ mA. If the VCM pins of several devices are connected in parallel, the external buffer should be capable of overcoming their collective output currents. When a common-mode voltage other than 2.5 V is used, a voltage-limiting resistor, R_{CLMP}, is needed to protect against overload.

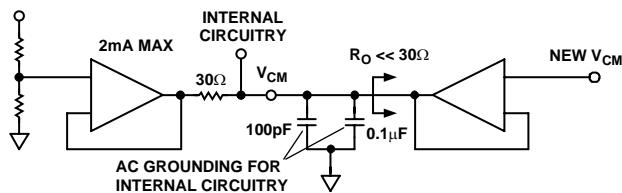

Figure 68. VCM Interface

Logic Inputs—ENB, MODE, and HILO

The input impedance of all enable pins is nominally 25 kΩ and may be pulled up to 5 V (a pull-up resistor is recommended) or driven by any 3 V or 5 V logic families. The enable pins perform a power-down function, when disabled, the VGA outputs are near ground. Multiple devices may be driven from a common source. Consult the pin-function tables for circuit functions controlled by the enable pins.

Pin HILO is compatible with 3 V or 5 V CMOS logic families. It is either connected to ground or pulled up to 5 V, depending on the desired gain range and output noise.

Optional Output Voltage Limiting

The RCLMP pin provides the user with a means to limit the output voltage swing when used with loads that have no provisions for prevention of input overdrive. The peak-to-peak limited voltage is adjusted by a resistor to ground, and Table lists several voltage levels and the corresponding resistor value. Unconnected, the default limiting level is 4.5 V p-p.

Note that third harmonic distortion will increase as waveform amplitudes approach clipping. For lowest distortion, the clamp level should be set higher than the converter input span. A clamp level of 1.5 V p-p is recommended for a 1 V p-p linear output range, 2.7 V p-p for a 2 V p-p range, or 1 V p-p for a 0.5 V p-p operation. The best solution will be determined experimentally. Figure 69 shows third harmonic distortion as a function of the limiting level for a 2 V p-p output signal. A wider limiting level is desirable in HI gain mode.

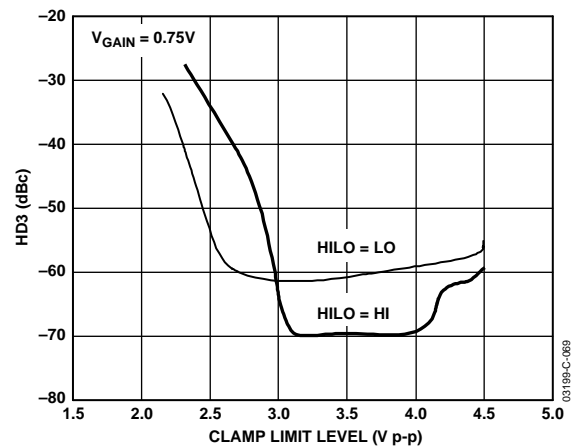

Figure 69. HD3 vs. Clamping Level for 2V p-p Differential Input

AD8331/AD8332

Table 4. Clamp Resistor Values

Clamp Level (V p-p)	Clamp Resistor Value (kΩ)	
	HILO = LO	HILO = HI
0.5	1.21	
1.0	2.74	2.21
1.5	4.75	4.02
2.0	7.5	6.49
2.5	11	9.53
3.0	16.9	14.7
3.5	26.7	23.2
4.0	49.9	39.2
4.4	100	73.2

Output Filtering and Series Resistor Requirements

To ensure stability at the high end of the gain control range, series resistors or ferrite beads are recommended for the outputs when driving large capacitive loads, or circuits on other boards. These components can be part of the external noise filter.

Recommended resistor values are 84.5 Ω for LO gain mode and 100 Ω for HI gain mode (see Figure 66) and are placed near Pins VOH and VOL. Lower value resistors are permissible for applications with nearby loads or with gains less than 40 dB. Lower values are best selected empirically.

An antialiasing noise filter is typically used with an ADC. Filter requirements are application dependent.

When the ADC resides on a separate board, the majority of filter components should be placed nearby to suppress noise picked up between boards and mitigates charge kickback from the ADC inputs. Any series resistance beyond that required for output stability should be placed on the ADC board. Figure 70 shows a second order low-pass filter with a bandwidth of 20 MHz. The capacitor is chosen in conjunction with the 10 pF input capacitance of the ADC.

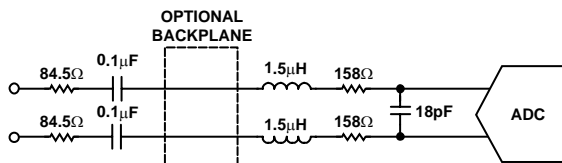

Figure 70. 20 MHz Second-Order Low-Pass Filter

DRIVING ADCS

The output drive will accommodate a wide range of ADCs. The noise floor requirements of the VGA will depend on a number of application factors, including bit resolution, sampling rate, full-scale voltage, and the bandwidth of the noise/antialias filter. The output noise floor and gain range can be adjusted by selecting HI or LO gain mode.

The relative noise and distortion performance of the two gain modes can be compared in Figure 21 and Figure 27 through Figure 37. The 48 nV/√Hz noise floor of the LO gain mode is suited to converters with higher sampling rates or resolutions (such as 12 bits). Both gain modes can accommodate ADC full-scale voltages as high as 4 V p-p. Since distortion performance remains favorable for output voltages as high as 4 V p-p (see Figure 32), it is possible to lower the output-referred noise even further by using a resistive attenuator (or transformer) at the output. The circuit in Figure 71 has an output full-scale range of 2 V p-p, a gain range of -10.5 dB to +37.5 dB, and an output noise floor of 24 nV/√Hz, making it suitable for some 14-bit ADC applications.

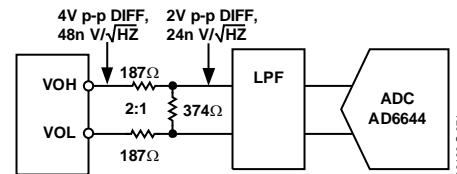

Figure 71. Adjusting the Noise Floor for 14-Bit ADCs

OVERLOAD

These devices respond gracefully to large signals that overload its input stage and to normal signals that overload the VGA when the gain is set unexpectedly high. Each stage is designed for clean-limited overload waveforms and fast recovery when gain setting or input amplitude is reduced.

Signals larger than ±275 mV at the LNA input are clipped to 5 V p-p differential prior to the input of the VGA. Figure 44 shows the response to a 1 V p-p input burst. The symmetric overload waveform is important for applications, such as CW Doppler ultrasound, where the spectrum of the LNA outputs during overload is critical. The input stage is also designed to accommodate signals as high as ±2.5 V without triggering the slow-settling ESD input protection diodes.

Both stages of the VGA are susceptible to overload. Postamp limiting is more common and results in the clean-limited output characteristics found in Figure 45. Under more extreme conditions, the X-AMP will overload, causing the minor glitches evident in Figure 46. Recovery is fast in all cases. The graph in Figure 72 summarizes the combinations of input signal and gain that lead to the different types of overload.

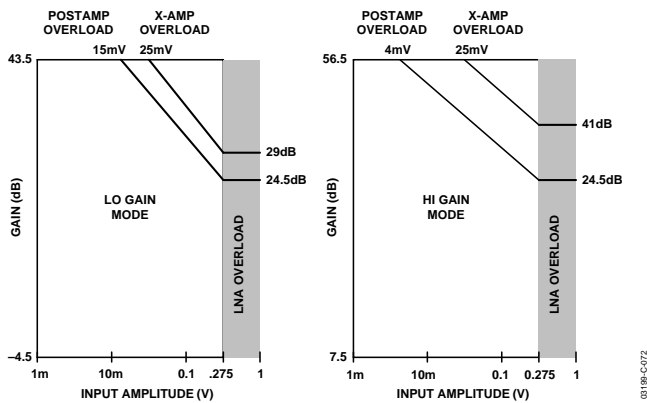

Figure 72. Overload Gain and Signal Conditions

The previously mentioned clamp interface controls the maximum output swing of the postamp and its overload response. When no R_{CLMP} resistor is provided, this level defaults to near 4.5 V p-p differential to protect outputs centered at a 2.5 V common mode. When other common-mode levels are set through the VCM pin, the value of R_{CLMP} should be chosen for graceful overload. A value of 8.3 k Ω or less is recommended for 1.5 V or 3.5 V common-mode levels (7.2 k Ω for HI gain mode). This limits the output swing to just above 2 V p-p diff.

OPTIONAL INPUT OVERLOAD PROTECTION.

Applications in which high transients are applied to the LNA input may benefit from the use of clamp diodes. A pair of back-to-back Schottky diodes can reduce these transients to manageable levels. Figure 73 illustrates how such a diode-protection scheme may be connected.

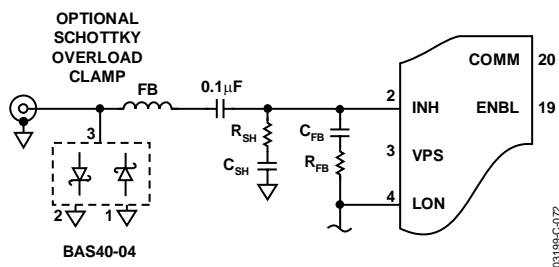

Figure 73. Input Overload Clamping

When selecting overload protection, the important parameters are forward and reverse voltages and t_{tr} (or τ_{tr}). The Infineon BAS40 series shown in Figure 73 has a τ_{tr} of 100 ps and V_F of 310 mV at 1 mA. Many variations of these specifications can be found in vendor catalogs.

LAYOUT, GROUNDING, AND BYPASSING

Due to their excellent high frequency characteristics, these devices are sensitive to their PCB environment. Realizing expected performance requires attention to detail critical to good high speed board design.

A multilayer board with power and ground plane is recommended, and unused area in the signal layers should be filled with ground. The multiple power and ground pins provide robust power distribution to the device and must all be connected. The power supply pins should each be with multiple values of high frequency ceramic chip capacitors to maintain low impedance paths to ground over a wide frequency range. These should have capacitance values of 0.01 μ F to 0.1 μ F in parallel with 100 pF to 1 nF, and be placed as close as possible to the pins. The LNA power pins should be decoupled from the VGA using ferrite beads. Together with the decoupling capacitors, ferrite beads help eliminate undesired high frequencies without reducing the headroom, as do small value resistors.

Several critical LNA areas require special care. The LON and LOP output traces must be as short as possible before connecting to the coupling capacitors connected to Pins VIN and VIP. R_{FB} must be placed nearby the LON pin as well. Resistors must be placed as close as possible to the VGA output pins VOL and VOH to mitigate loading effects of connecting traces. Values are discussed in the section entitled Output Filtering and Series Resistor Requirements.

Signal traces must be short and direct to avoid parasitic effects. Wherever there are complementary signals, symmetrical layout should be employed to maintain waveform balance. PCB traces should be kept adjacent when running differential signals over a long distance.

MULTIPLE INPUT MATCHING

Matching of multiple sources with dissimilar impedances can be accomplished as shown in the circuit of Figure 75. A relay and low supply voltage analog switch may be used to select between multiple sources and their associated feedback resistors. An ADG736 dual SPDT switch is shown in this example; however, multiple switches are also available and users are referred to the Analog Devices Selection Guide for switches and multiplexers.

DISABLING THE LNA

Where accessible, connection of the LNA enable pin to ground will power down the LNA, resulting in a current reduction of about half. In this mode, the LNA input and output pins may be left unconnected, however the power must be connected to all the supply pins for the disabling circuit to function. Figure 74 illustrates the connections using an AD8331 as an example.

AD8331/AD8332

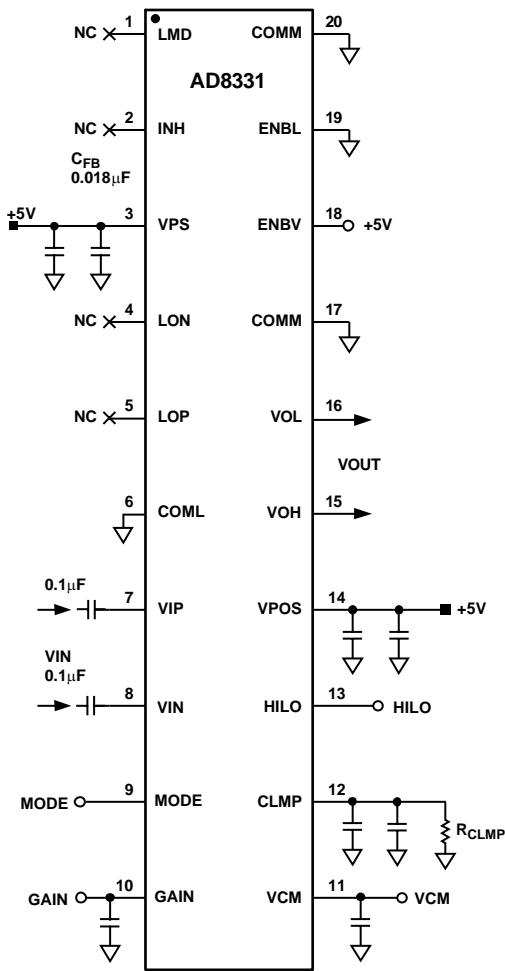

Figure 74. Disabling the LNA

03199-C-074

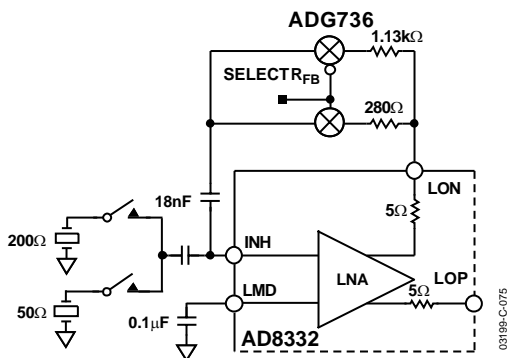

Figure 75. Accommodating Multiple Sources

03199-C-075

MEASUREMENT CONSIDERATIONS

Figure 51 through Figure 55 show typical measurement configurations and proper interface values for measurements with 50 Ω conditions.

Short-circuit input noise measurements are made using Figure 53. The input-referred noise level is determined by dividing the output noise by the numerical gain between Point A and Point B and accounting for the noise floor of the spectrum analyzer. The gain should be measured at each frequency of interest and with low signal levels since a 50 Ω load is driven directly. The generator is removed when noise measurements are made.

ULTRASOUND TGC APPLICATION

The AD8332 ideally meets the requirements of medical and industrial ultrasound applications. The TGC amplifier is a key subsystem in such applications, since it provides the means for echolocation of reflected ultrasound energy.

Figure 76 through Figure 78 are schematics of a dual, fully differential system using the AD8332 and AD9238 12-bit high speed ADC with conversion speeds as high as 65 MSPS. In this example, the VGA outputs are dc-coupled, using the reference output of the ADC and a level shifter to center the common-mode output voltage to match that of the converter. Consult the data sheet of the converter to determine whether external CMV biasing is required. AC coupling is recommended if the CMV of the VGA and ADC are widely disparate.

Using the circuit shown, and a high speed ADC FIFO evaluation kit connected to a laptop PC, an FFT can be performed on the AD8332. With the on-board clock of 20 MHz, and minimal low-pass filtering, and both channels driven with a 1 MHz filtered sine wave, the THD is -75 dB, noise floor -93 dB and HD2 -83 dB.

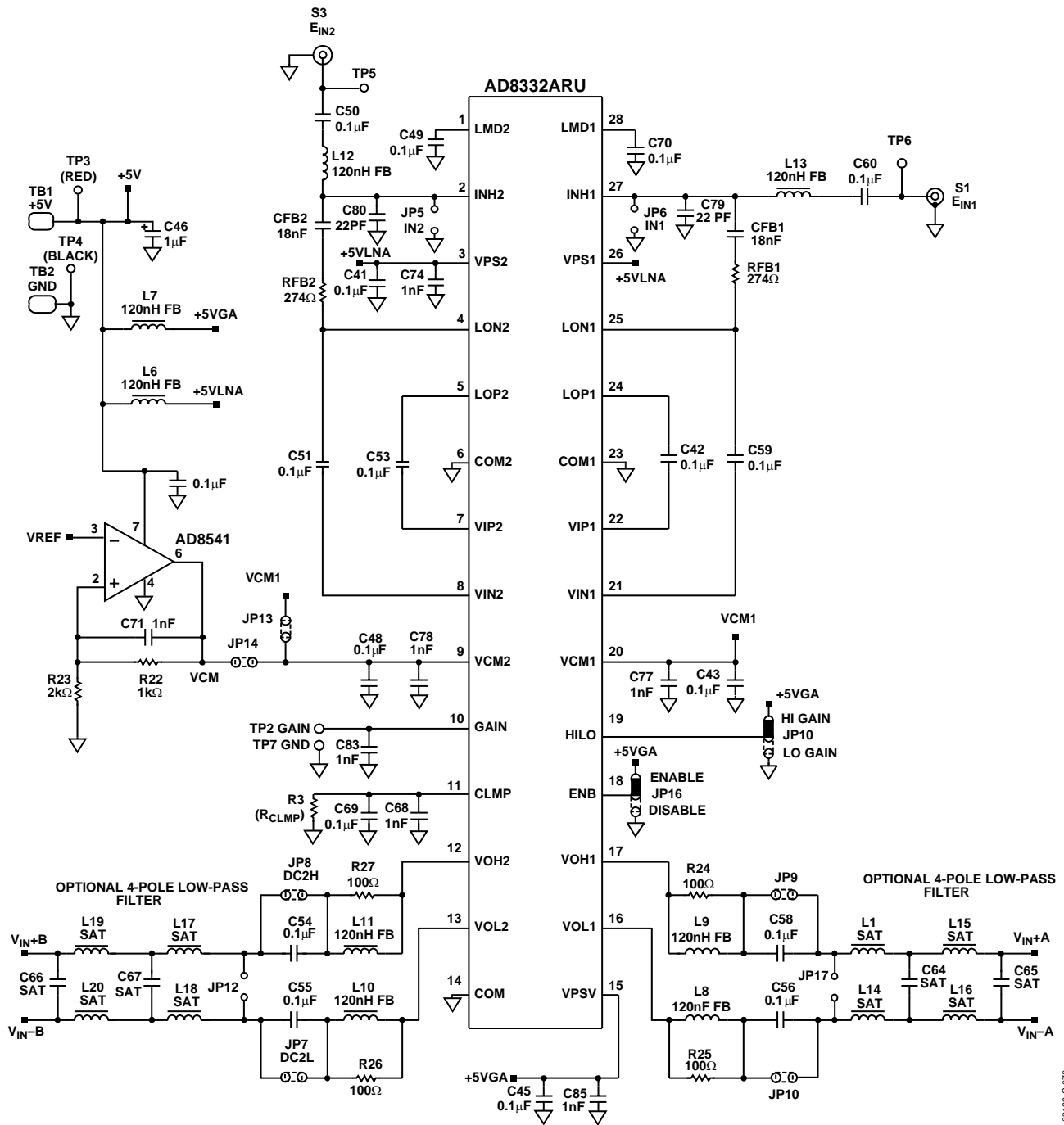

Figure 76. Schematic, TGC, VGA Section

AD8331/AD8332

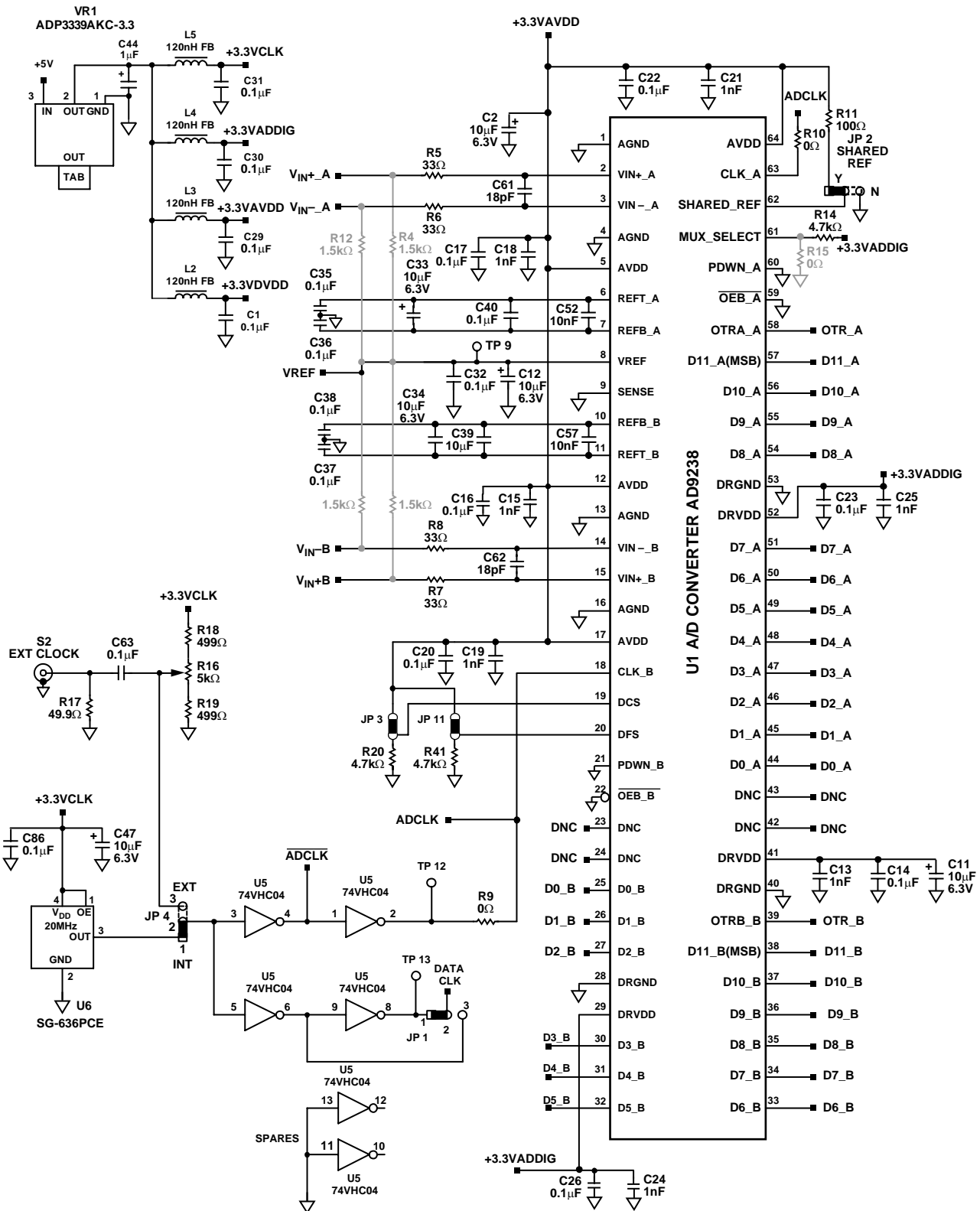

Figure 77. Converter Schematic

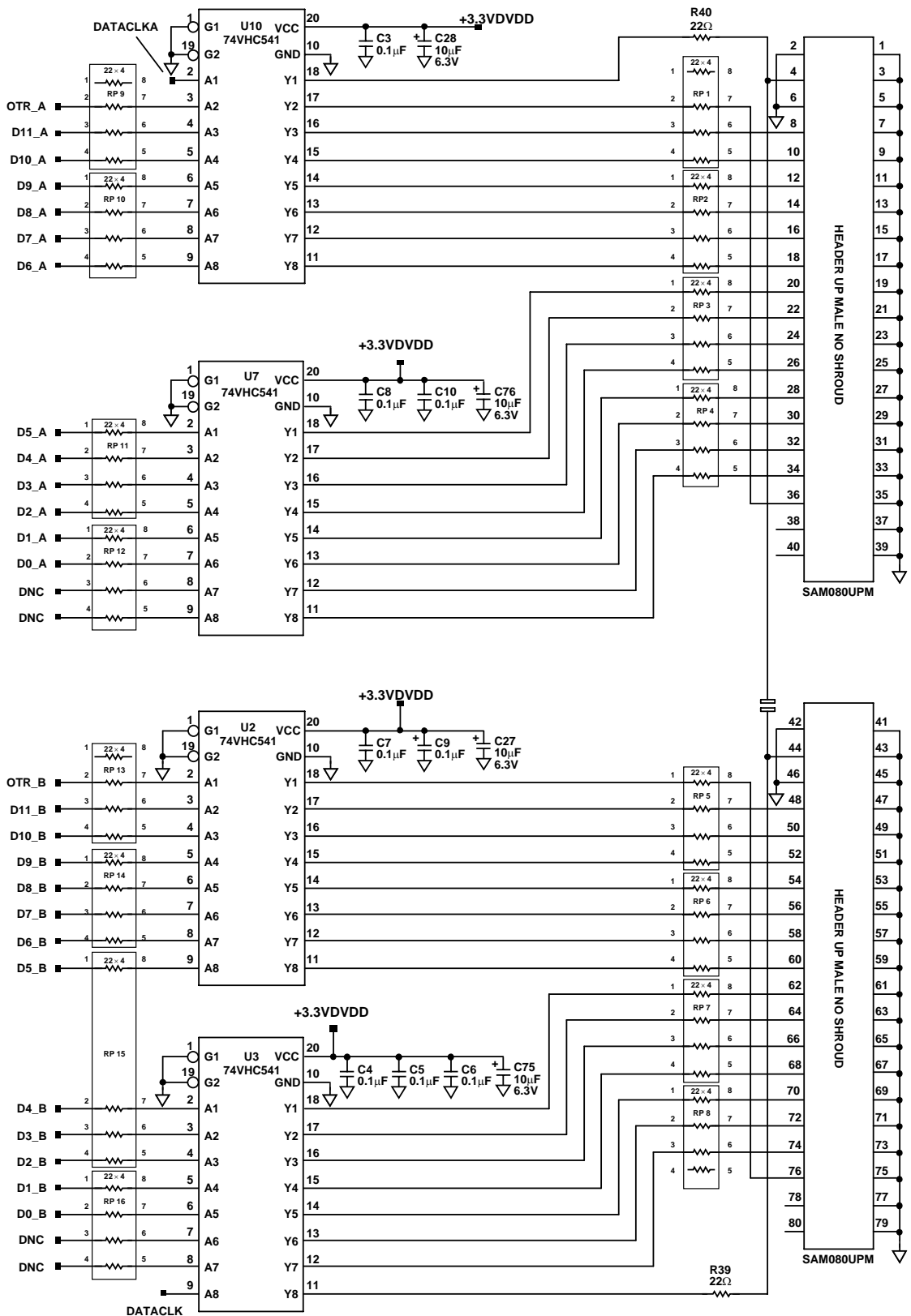

Figure 78. Interface Schematic

AD8331/AD8332

PIN CONFIGURATION AND FUNCTION DESCRIPTIONS

AD8331

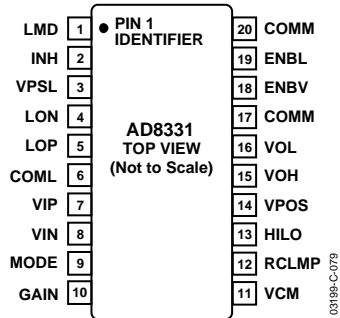

Figure 79. 20-Lead QSOP

Table 5. 20-Lead QSOP (RQ PACKAGE)

Pin No.	Name	Description
1	LMD	LNA Signal Ground
2	INH	LNA Input
3	VPSL	LNA 5V Supply
4	LON	LNA Inverting Output
5	LOP	LNA Noninverting Output
6	COML	LNA Ground
7	VIP	VGA Noninverting Input
8	VIN	VGA Inverting Input
9	MODE	Gain Slope Logic Input
10	GAIN	Gain Control Voltage
11	VCM	Common-Mode Voltage
12	CLMP	Output Clamping Level
13	HILO	Gain Range Select (HI or LO)
14	VPOS	VGA 5 V Supply
15	VOH	Noninverting VGA Output
16	VOL	Inverting VGA Output
17	COMM	VGA Ground
18	ENBV	VGA Enable
19	ENBL	LNA Enable
20	COMM	VGA Ground

AD8332

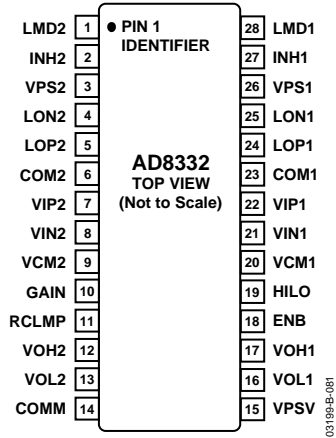

Figure 80. 28-Lead TSSOP

Table 6. 28-Lead TSSOP (AR PACKAGE)

Pin No.	Name	Description
1	LMD2	CH2 LNA Signal Ground
2	INH2	CH2 LNA Input
3	VPS2	CH2 Supply LNA 5 V
4	LON2	CH2 LNA Inverting Output
5	LOP2	CH2 LNA Noninverting Output
6	COM2	CH2 LNA Ground
7	VIP2	CH2 VGA Noninverting Input
8	VIN2	CH2 VGA Inverting Input
9	VCM2	CH2 Common-Mode Voltage
10	GAIN	Gain Control Voltage
11	RCLMP	Output Clamping Resistor
12	VOH2	CH2 Noninverting VGA Output
13	VOL2	CH2 Inverting VGA Output
14	COMM	VGA Ground (Both Channels)
15	VPSV	VGA Supply 5 V (Both Channels)
16	VOL1	CH1 Inverting VGA Output
17	VOH1	CH1 Noninverting VGA Output
18	ENB	Enable—VGA/LNA
19	HILO	VGA Gain Range Select (HI or LO)
20	VCM1	CH1 Common-Mode Voltage
21	VIN1	CH1 VGA Inverting Input
22	VIP1	CH1 VGA Noninverting Input
23	COM1	CH1 LNA Ground
24	LOP1	CH1 LNA Noninverting Output
25	LON1	CH1 LNA Inverting Output
26	VPS1	CH1 LNA Supply 5 V
27	INH1	CH1 LNA Input
28	LMD1	CH1 LNA Signal Ground

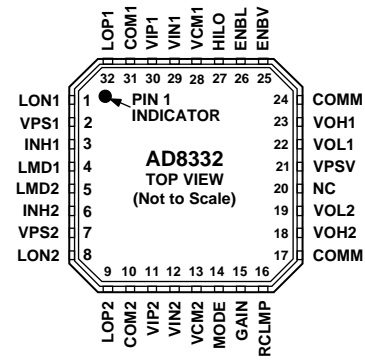

Figure 81. 32-Lead LFCSP

Table 7. 32-Lead LFCSP (AC PACKAGE)

Pin No.	Name	Description
1	LON1	CH1 LNA Inverting Output
2	VPS1	CH1 LNA Supply 5 V
3	INH1	CH1 LNA Input
4	LMD1	CH1 LNA Signal Ground
5	LMD2	CH2 LNA Signal Ground
6	INH2	CH2 LNA Input
7	VPS2	CH2 LNA Supply 5 V
8	LON2	CH2 LNA Inverting Output
9	LOP2	CH2 LNA Noninverting Output
10	COM2	CH2 LNA Ground
11	VIP2	CH2 VGA Noninverting Input
12	VIN2	CH2 VGA Inverting Input
13	VCM2	CH2 Common-Mode Voltage
14	MODE	Gain Slope Logic Input
15	GAIN	Gain Control Voltage
16	RCLMP	Output Clamping Level Input
17	COMM	VGA Ground
18	VOH2	CH2 Noninverting VGA Output
19	VOL2	CH2 Inverting VGA Output
20	NC	Not Connected
21	VPSV	VGA Supply 5 V
22	VOL1	CH1 Inverting VGA Output
23	VOH1	CH1 Noninverting VGA Output
24	COMM	VGA Ground
25	ENBV	VGA Enable
26	ENBL	LNA Enable
27	HILO	VGA Gain Range Select (HI or LO)
28	VCM1	CH1 Common-Mode Voltage
29	VIN1	CH1 VGA Inverting Input
30	VIP1	CH1 VGA Noninverting Input
31	COM1	CH1 LNA Ground
32	LOP1	CH1 LNA Noninverting Output

AD8331/AD8332

OUTLINE DIMENSIONS

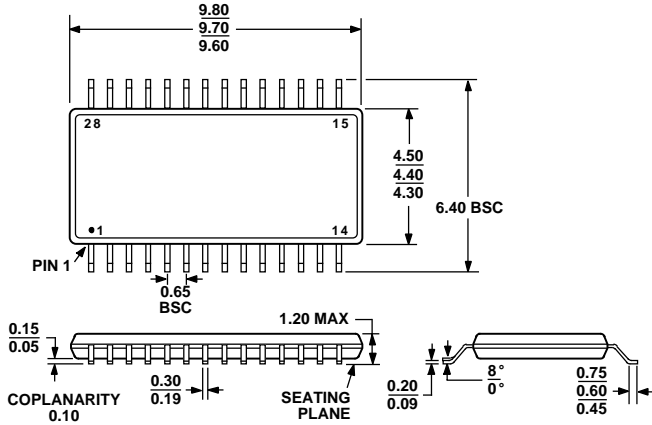

COMPLIANT TO JEDEC STANDARDS MO-153AE

Figure 82. 28-Lead Thin Shrink Small Outline Package [TSSOP] (RU-28)
Dimensions shown in millimeters

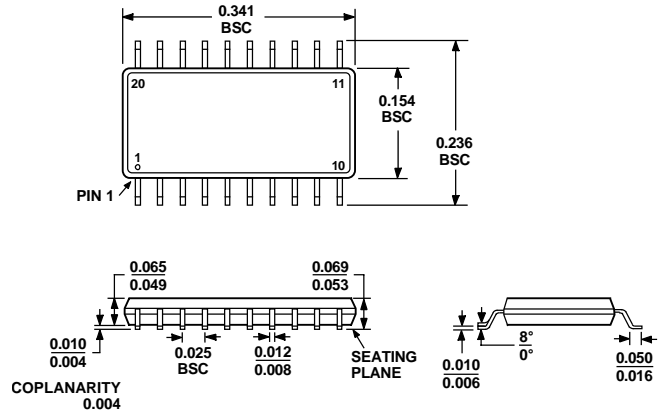

COMPLIANT TO JEDEC STANDARDS MO-137AD

Figure 84. 20 Lead Shrink Outline [QSOP] (RQ-20)
Dimensions shown in millimeters

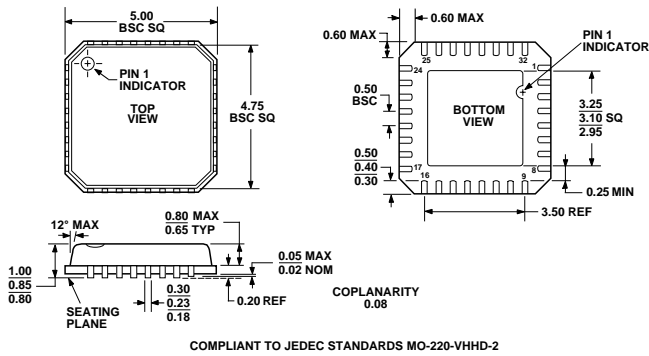

COMPLIANT TO JEDEC STANDARDS MO-220-VHHD-2

Figure 83. 32-Lead Frame Chip Scale Package [LFCSP] (CP-32)
Dimensions shown in millimeters

ORDERING GUIDE

AD8331/AD8332 Models	Temperature Range	Package Description	Package Outline
AD8331ARQ	-40°C to +85°C	Shrink Small Outline Package 150 mil Body, 25 mil pitch	RQ-20
AD8331ARQ-REEL	-40°C to +85°C	Shrink Small Outline Package 150 mil Body, 25 mil pitch	RQ-20
AD8331ARQ-REEL7	-40°C to +85°C	Shrink Small Outline Package 150 mil Body, 25 mil pitch	RQ-20
AD8331-EVAL		Evaluation Board with AD8331ARQ	
AD8332ARU	-40°C to +85°C	Thin Shrink Small Outline Package (TSSOP)	RU-28
AD8332ARU-REEL	-40°C to +85°C	Thin Shrink Small Outline Package (TSSOP)	RU-28
AD8332ARU-REEL7	-40°C to +85°C	Thin Shrink Small Outline Package (TSSOP)	RU-28
AD8332ACP-REEL	-40°C to +85°C	Lead Frame Chip Scale Package (LFCSP)	CP-32
AD8332ACP-REEL7	-40°C to +85°C	Lead Frame Chip Scale Package (LFCSP)	CP-32
AD8332-EVAL		Evaluation Board with AD8332ARU	