

# 5800 AND 5801

## BiMOS II LATCHED DRIVERS

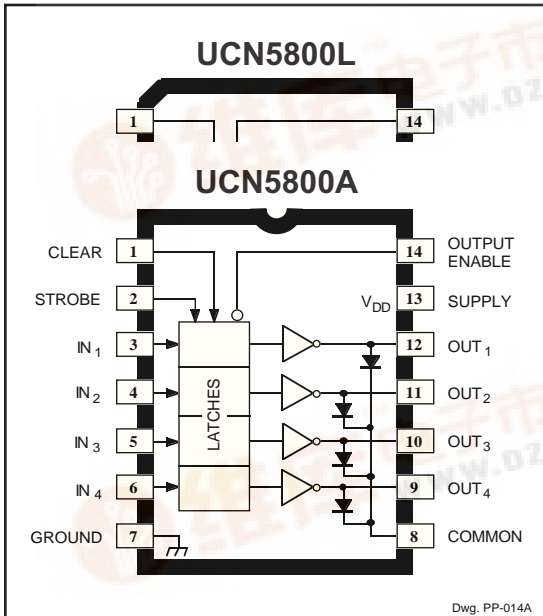

Dwg. PP-014A

Note the UCN5800A (DIP) and the UCN5800L (SOIC) are electrically identical and share a common terminal number assignment.

### ABSOLUTE MAXIMUM RATINGS at +25°C Free-Air Temperature

Output Voltage, $V_{CE}$ .....	50 V
Supply Voltage, $V_{DD}$ .....	15 V
Input Voltage Range, $V_{IN}$ .....	-0.3 V to $V_{DD} + 0.3$ V
Continuous Collector Current, $I_C$ .....	500 mA
Package Power Dissipation, $P_D$ .....	See Graph
Operating Temperature Range, $T_A$ .....	-20°C to +85°C
Storage Temperature Range, $T_S$ .....	-55°C to +150°C

Caution: CMOS devices have input static protection but are susceptible to damage when exposed to extremely high static electrical charges.

The UCN5800A/L and UCN5801A/EP/LW latched-input BiMOS ICs merge high-current, high-voltage outputs with CMOS logic. The CMOS input section consists of 4 or 8 data ('D' type) latches with associated common CLEAR, STROBE, and OUTPUT ENABLE circuitry. The power outputs are bipolar npn Darlington. This merged technology provides versatile, flexible interface. These BiMOS power interface ICs greatly benefit the simplification of computer or microprocessor I/O. The UCN5800A and UCN5800L each contain four latched drivers; the UCN5801A, UCN5801EP, and UCN5801LW contain eight latched drivers.

The UCN5800A/L and UCN5801A/EP/LW supersede the original BiMOS latched-input driver ICs (UCN4400A and UCN4801A). These second-generation devices are capable of much higher data input rates and will typically operate at better than 5 MHz with a 5 V logic supply. Circuit operation at 12 V affords substantial improvement over the 5 MHz figure.

The CMOS inputs are compatible with standard CMOS and NMOS circuits. TTL circuits may mandate the addition of input pull-up resistors. The bipolar Darlington outputs are suitable for directly driving many peripheral/power loads: relays, lamps, solenoids, small dc motors, etc.

All devices have open-collector outputs and integral diodes for inductive load transient suppression. The output transistors are capable of sinking 500 mA and will withstand at least 50 V in the OFF state. Because of limitations on package power dissipation, the simultaneous operation of all drivers at maximum rated current can only be accomplished by a reduction in duty cycle. Outputs may be paralleled for higher load current capability.

The UCN5800A is furnished in a standard 14-pin DIP; the UCN5800L and UCN5801LW in surface-mountable SOICs; the UCN5801A in a 22-pin DIP with 0.400" (10.16 mm) row centers; the UCN5801EP in a 28-lead PLCC.

### FEATURES

- To 4.4 MHz Data Input Rate
- High-Voltage, High-Current Outputs
- CMOS, NMOS, TTL Compatible Inputs
- Output Transient Protection
- Internal Pull-Down Resistors
- Low-Power CMOS Latches
- Automotive Capable

Always order by complete part number, e.g., **UCN5801EP**.

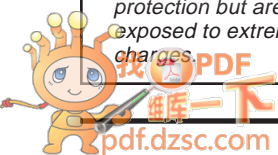

# 5800 AND 5801 BiMOS II LATCHED DRIVERS

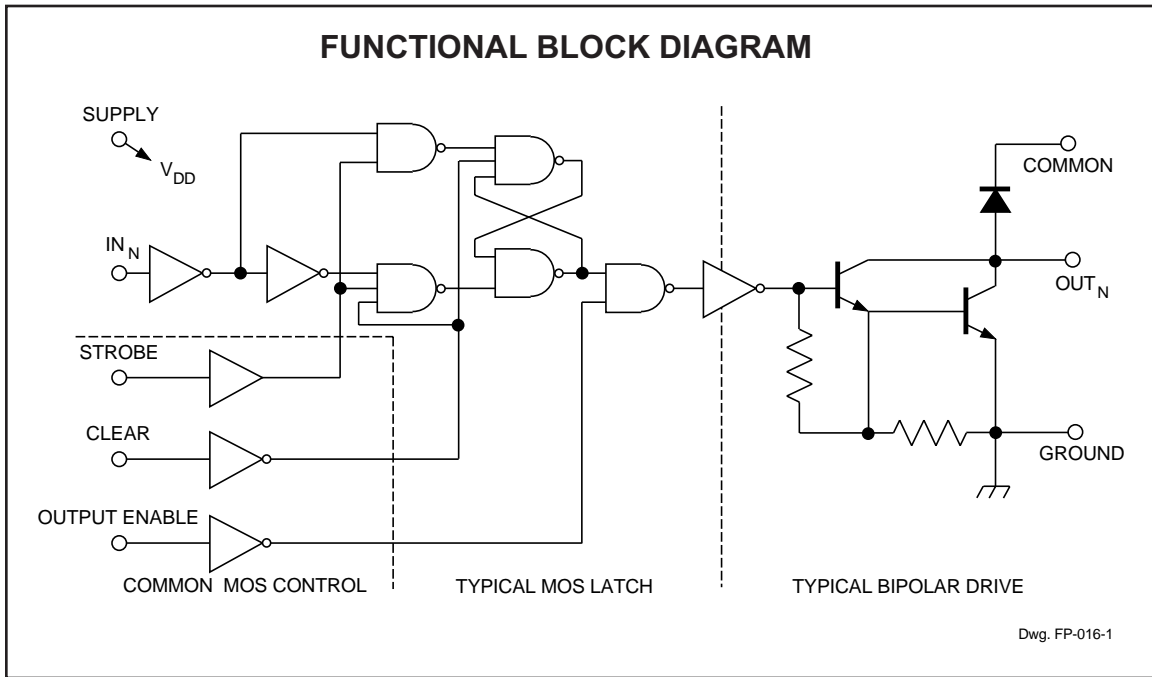

### TYPICAL INPUT CIRCUIT

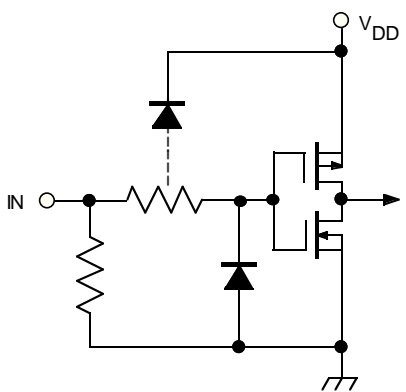

Dwg. EP-010-4A

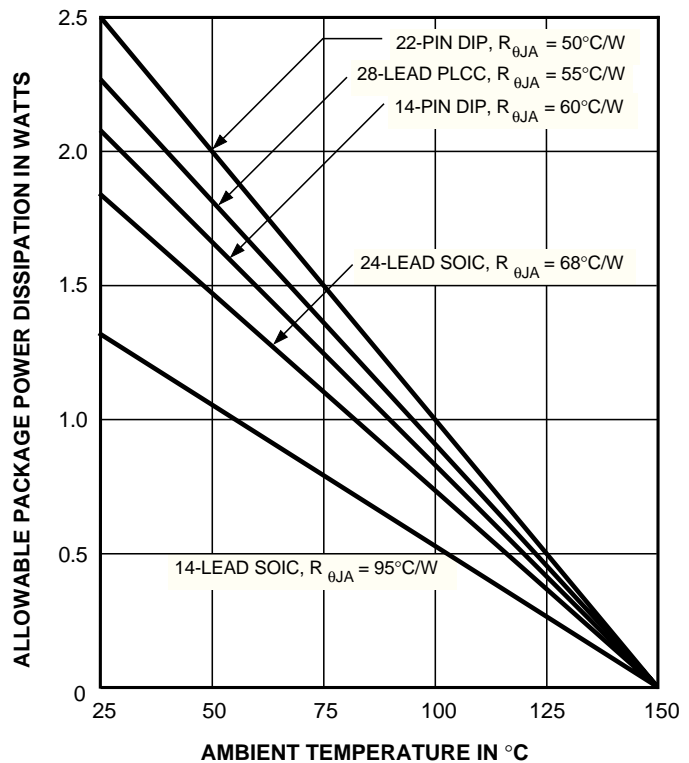

Dwg. GP-023-1

# 5800 AND 5801 BiMOS II LATCHED DRIVERS

## ELECTRICAL CHARACTERISTICS at $T_A = +25^\circ\text{C}$ , $V_{DD} = 5\text{ V}$ (unless otherwise noted).

Characteristic	Symbol	Test Conditions	Limits			
			Min.	Typ.	Max.	Units
Output Leakage Current	$I_{CEX}$	$V_{CE} = 50\text{ V}$ , $T_A = +25^\circ\text{C}$	—	—	50	$\mu\text{A}$
		$V_{CE} = 50\text{ V}$ , $T_A = +70^\circ\text{C}$	—	—	100	$\mu\text{A}$
Collector-Emitter Saturation Voltage	$V_{CE(SAT)}$	$I_C = 100\text{ mA}$	—	0.9	1.1	V
		$I_C = 200\text{ mA}$	—	1.1	1.3	V
		$I_C = 350\text{ mA}$ , $V_{DD} = 7.0\text{ V}$	—	1.3	1.6	V
Input Voltage	$V_{IN(0)}$		—	—	1.0	V
	$V_{IN(1)}$	$V_{DD} = 12\text{ V}$	10.5	—	—	V
		$V_{DD} = 10\text{ V}$	8.5	—	—	V
	$V_{DD} = 5.0\text{ V}$ (See Note)	3.5	—	—	V	
Input Resistance	$r_{IN}$	$V_{DD} = 12\text{ V}$	50	200	—	$\text{k}\Omega$
		$V_{DD} = 10\text{ V}$	50	300	—	$\text{k}\Omega$
		$V_{DD} = 5.0\text{ V}$	50	600	—	$\text{k}\Omega$
Supply Current	$I_{DD(ON)}$ (Each Stage)	$V_{DD} = 12\text{ V}$ , Outputs Open	—	1.0	2.0	$\text{mA}$
		$V_{DD} = 10\text{ V}$ , Outputs Open	—	0.9	1.7	$\text{mA}$
		$V_{DD} = 5.0\text{ V}$ , Outputs Open	—	0.7	1.0	$\text{mA}$
	$I_{DD(OFF)}$ (Total)	$V_{DD} = 12\text{ V}$ , Outputs Open, Inputs = 0 V	—	—	200	$\mu\text{A}$
		$V_{DD} = 5.0\text{ V}$ , Outputs Open, Inputs = 0 V	—	50	100	$\mu\text{A}$
Clamp Diode Leakage Current	$I_R$	$V_R = 50\text{ V}$ , $T_A = +25^\circ\text{C}$	—	—	50	$\mu\text{A}$
		$V_R = 50\text{ V}$ , $T_A = +70^\circ\text{C}$	—	—	100	$\mu\text{A}$
Clamp Diode Forward Voltage	$V_F$	$I_F = 350\text{ mA}$	—	1.7	2.0	V

NOTE: Operation of these devices with standard TTL or DTL may require the use of appropriate pull-up resistors to ensure a minimum logic "1".

**UCN5801EP**  
(additional pinout diagrams  
are on next page)

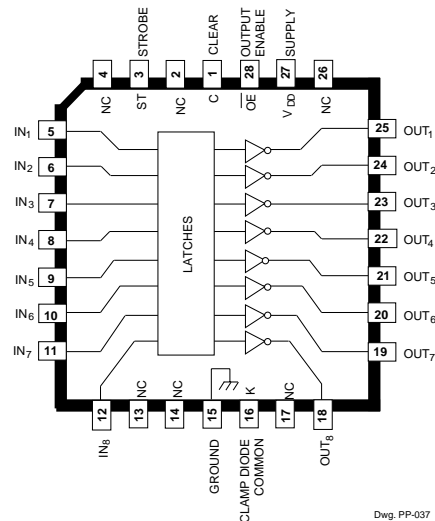

# 5800 AND 5801 BiMOS II LATCHED DRIVERS

## UCN5801A

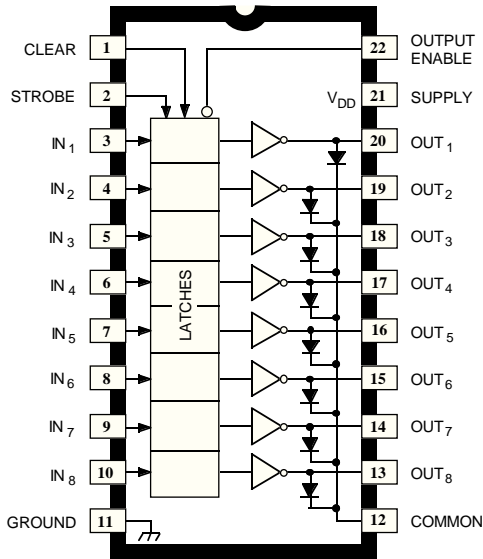

Dwg. PP-015

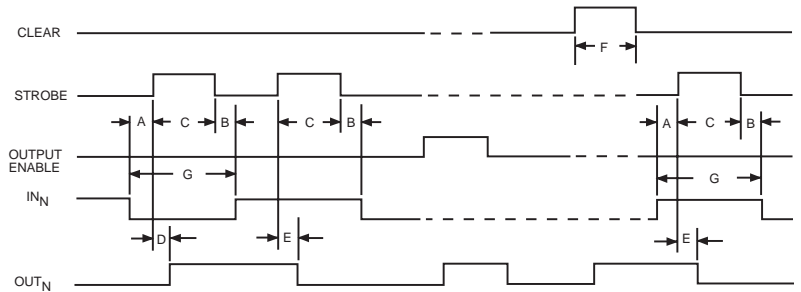

Dwg. No. A-10,895A

### TIMING CONDITIONS (Logic Levels are $V_{DD}$ and Ground)

- A. Minimum Data Active Time Before Strobe Enabled  
(Data Set-Up Time) ..... **50 ns**
- B. Minimum Data Active Time After Strobe Disabled  
(Data Hold Time) ..... **50 ns**
- C. Minimum Strobe Pulse Width ..... **125 ns**
- D. Typical Time Between Strobe Activation and  
Output On to Off Transition ..... **500 ns**
- E. Minimum Time Between Strobe Activation and  
Output Off to On Transition ..... **500 ns**
- F. Minimum Clear Pulse Width ..... **300 ns**
- G. Minimum Data Pulse Width ..... **225 ns**

Information present at an input is transferred to its latch when the STROBE is high. A high CLEAR input will set all latches to the output OFF condition regardless of the data or STROBE input levels. A high OUTPUT ENABLE will set all outputs to the OFF condition, regardless of any other input conditions. When the OUTPUT ENABLE is low, the outputs depend on the state of their respective latches.

### TRUTH TABLE

IN <sub>N</sub>	STROBE	CLEAR	OUTPUT ENABLE	OUT <sub>N</sub>	
				t-1	t
0	1	0	0	X	OFF
1	1	0	0	X	ON
X	X	1	X	X	OFF
X	X	X	1	X	OFF
X	0	0	0	ON	ON
X	0	0	0	OFF	OFF

X = irrelevant.  
t-1 = previous output state.  
t = present output state.

## UCN5801LW

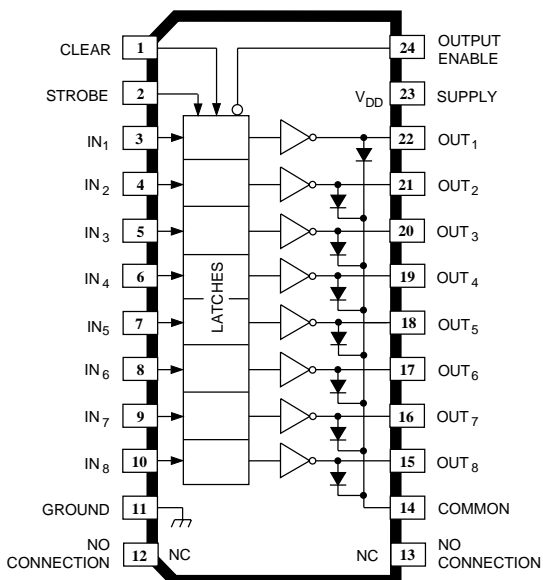

Dwg. PP-015-1

# 5800 AND 5801 BiMOS II LATCHED DRIVERS

## TYPICAL APPLICATION UNIPOLAR STEPPER-MOTOR DRIVE

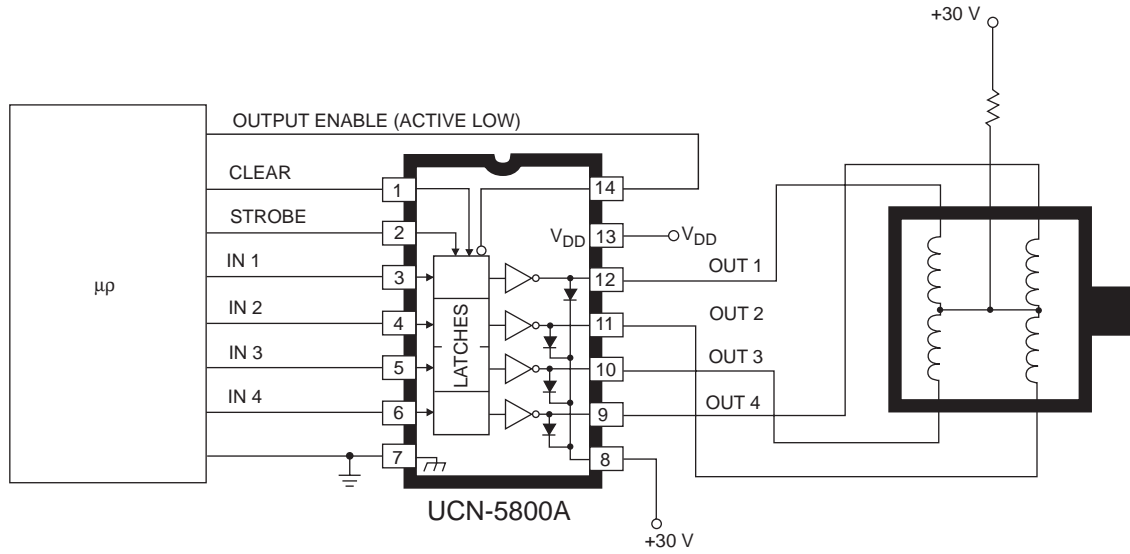

Dwg. No. B-1537

### UNIPOLAR WAVE DRIVE

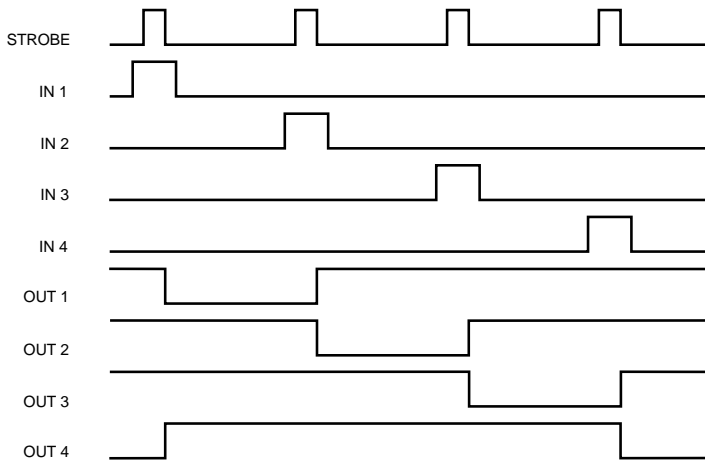

Dwg. GP-060

### UNIPOLAR 2-PHASE DRIVE

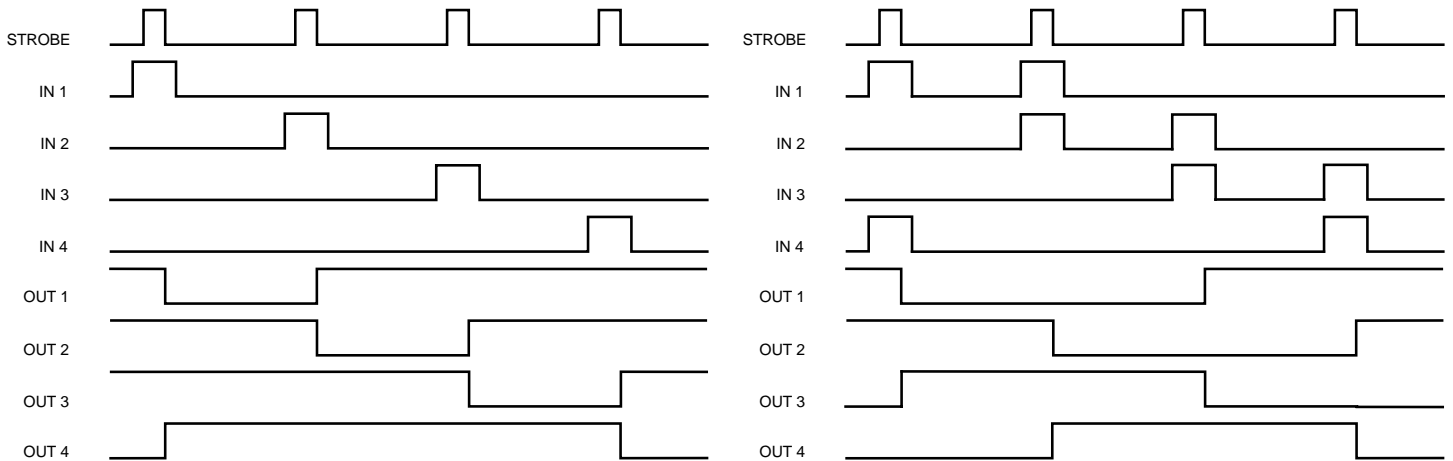

Dwg. GP-060-1

# 5800 AND 5801 BiMOS II LATCHED DRIVERS

## UCN5800A Dimensions in Inches (controlling dimensions)

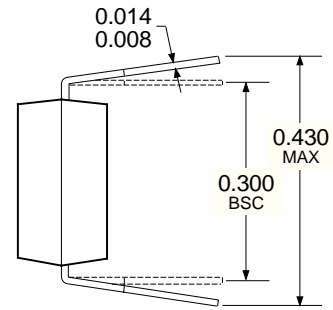
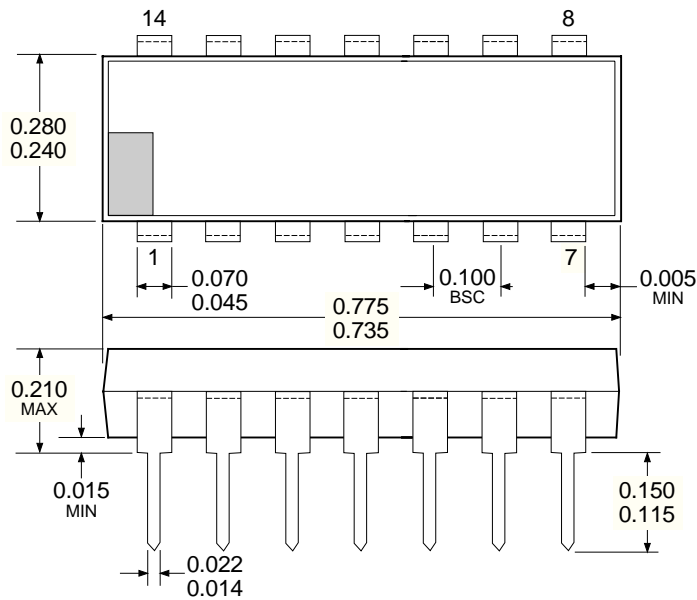

Dwg. MA-001-14A in

## Dimensions in Millimeters (for reference only)

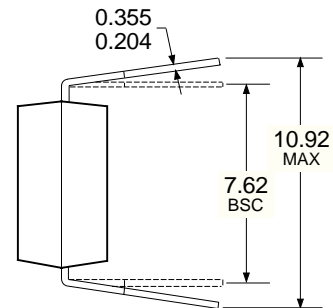
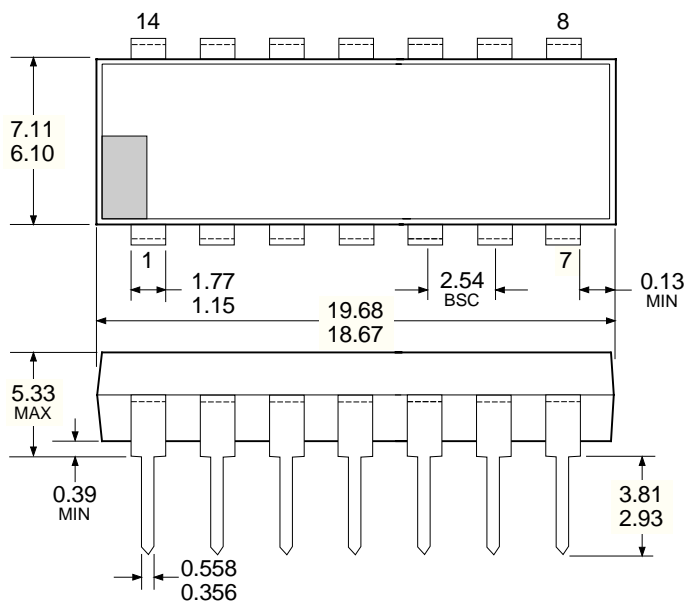

Dwg. MA-001-14A mm

- NOTES: 1. Exact body and lead configuration at vendor's option within limits shown.  
2. Lead spacing tolerance is non-cumulative.  
3. Lead thickness is measured at seating plane or below.

# 5800 AND 5801 BiMOS II LATCHED DRIVERS

## UCN5800L

Dimensions in Inches  
(for reference only)

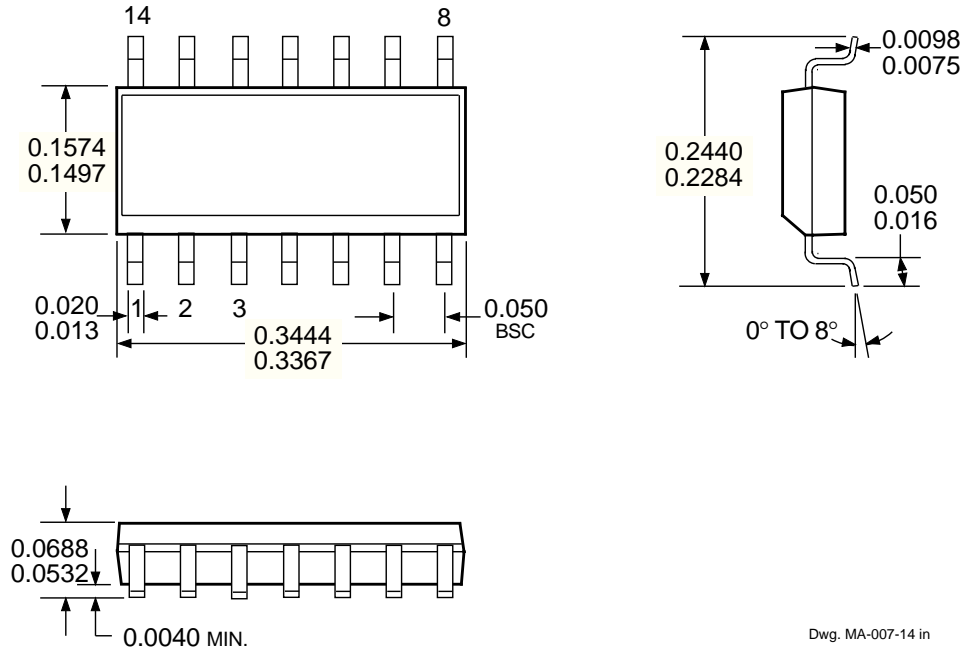

Dwg. MA-007-14 in

Dimensions in Millimeters  
(controlling dimensions)

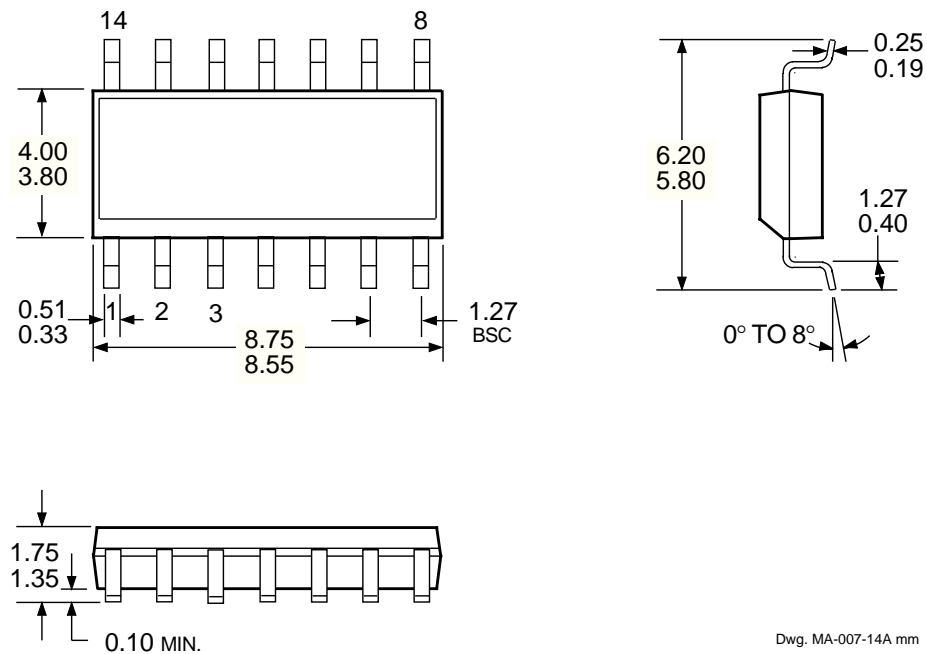

Dwg. MA-007-14A mm

- NOTES: 1. Exact body and lead configuration at vendor's option within limits shown.  
2. Lead spacing tolerance is non-cumulative.

# 5800 AND 5801 BiMOS II LATCHED DRIVERS

## UCN5801A Dimensions in Inches (controlling dimensions)

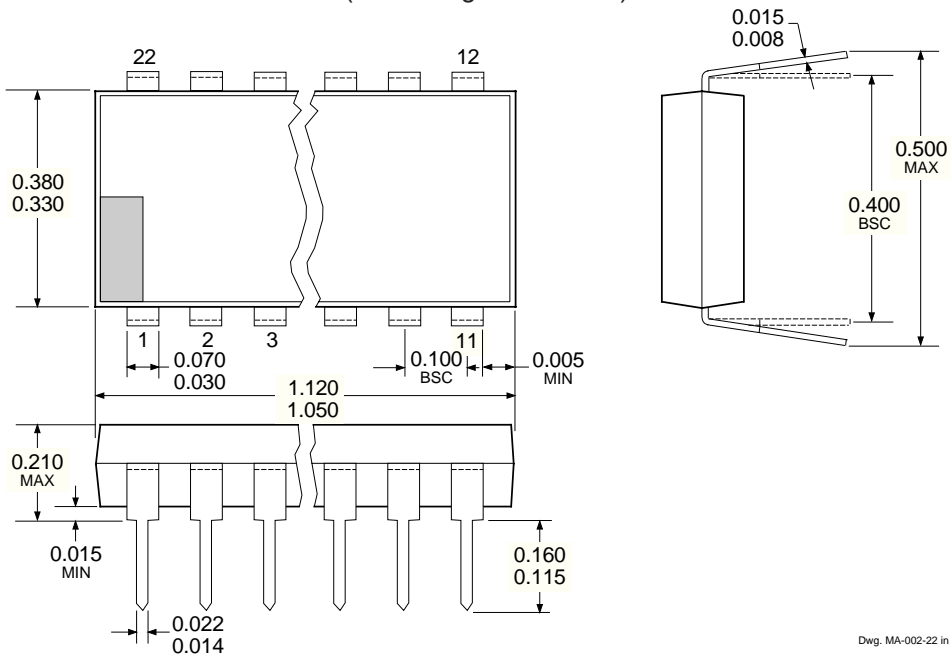

Dwg. MA-002-22 in

## Dimensions in Millimeters (for reference only)

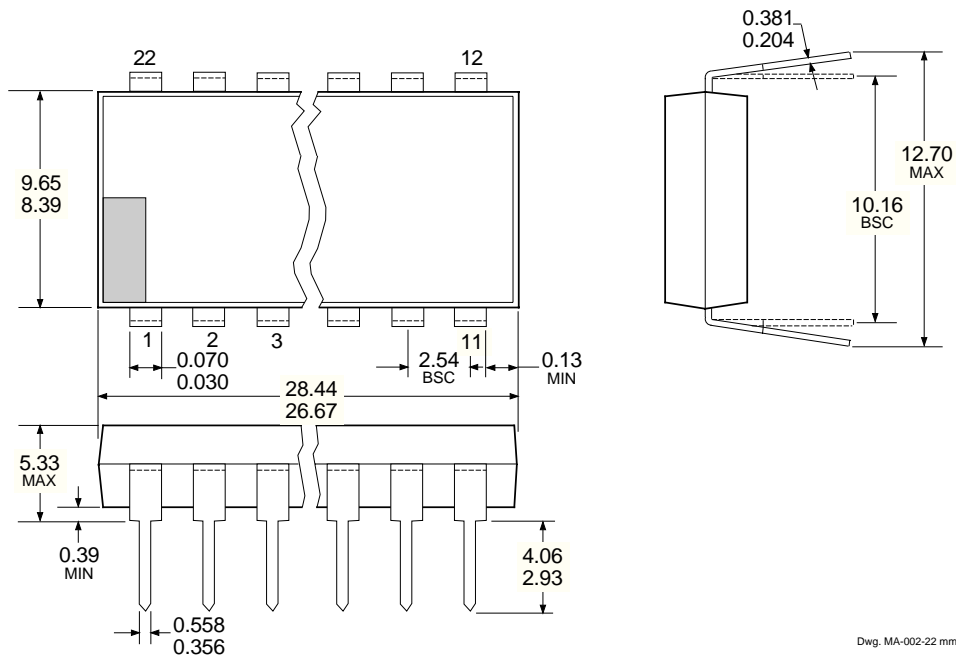

Dwg. MA-002-22 mm

- NOTES: 1. Exact body and lead configuration at vendor's option within limits shown.  
2. Lead spacing tolerance is non-cumulative.  
3. Lead thickness is measured at seating plane or below.



# 5800 AND 5801 BiMOS II LATCHED DRIVERS

## UCN5801EP Dimensions in Inches (controlling dimensions)

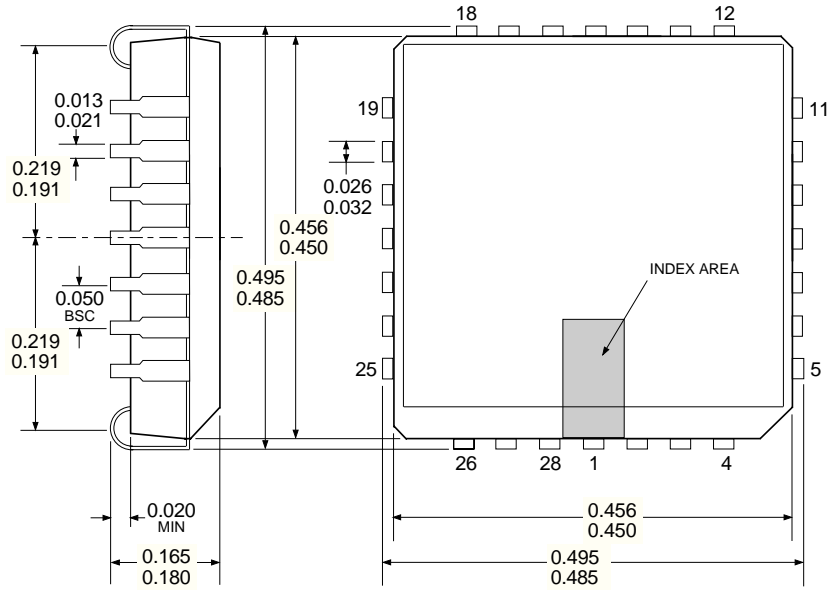

Dwg. MA-005-28A in

## Dimensions in Millimeters (for reference only)

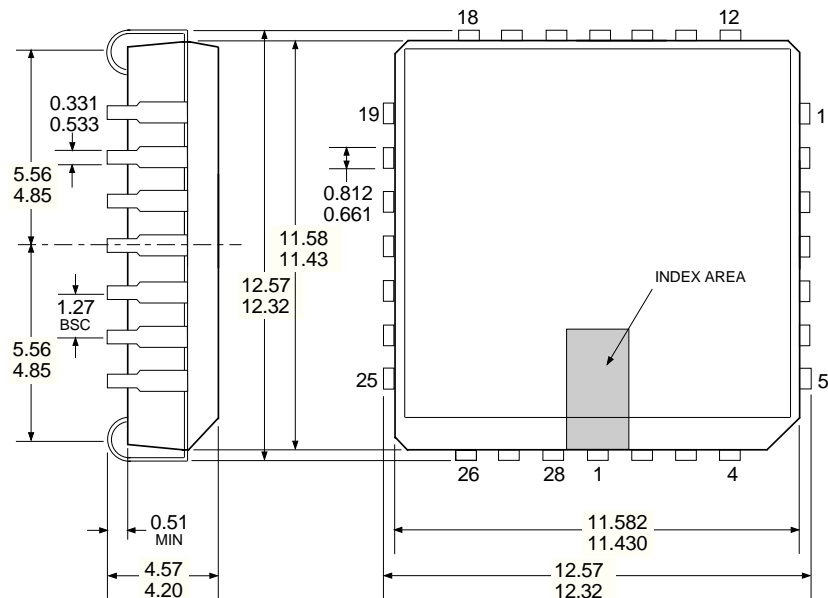

Dwg. MA-005-28A mm

- NOTES: 1. Exact body and lead configuration at vendor's option within limits shown.  
2. Lead spacing tolerance is non-cumulative.

# 5800 AND 5801 BiMOS II LATCHED DRIVERS

## UCN5801LW Dimensions in Inches (for reference only)

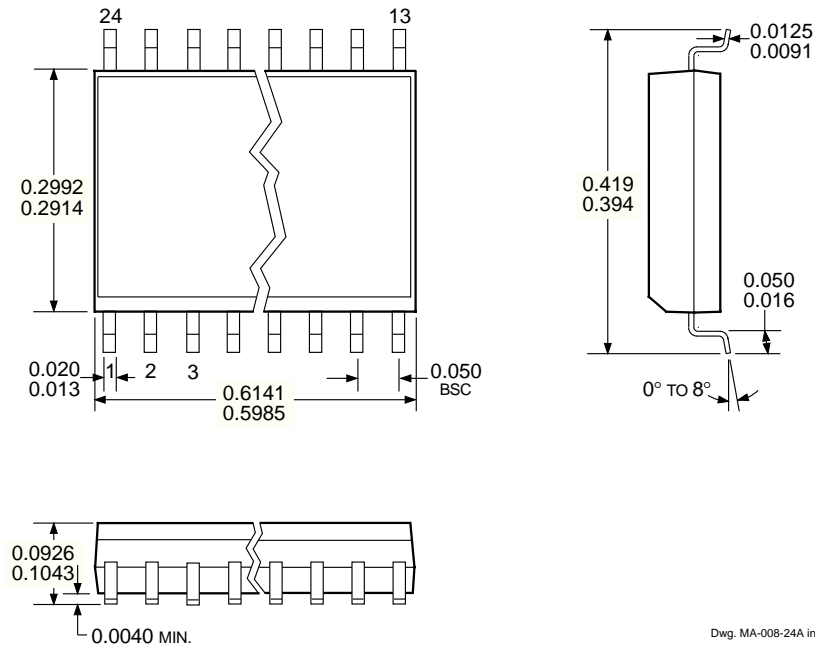

## Dimensions in Millimeters (controlling dimensions)

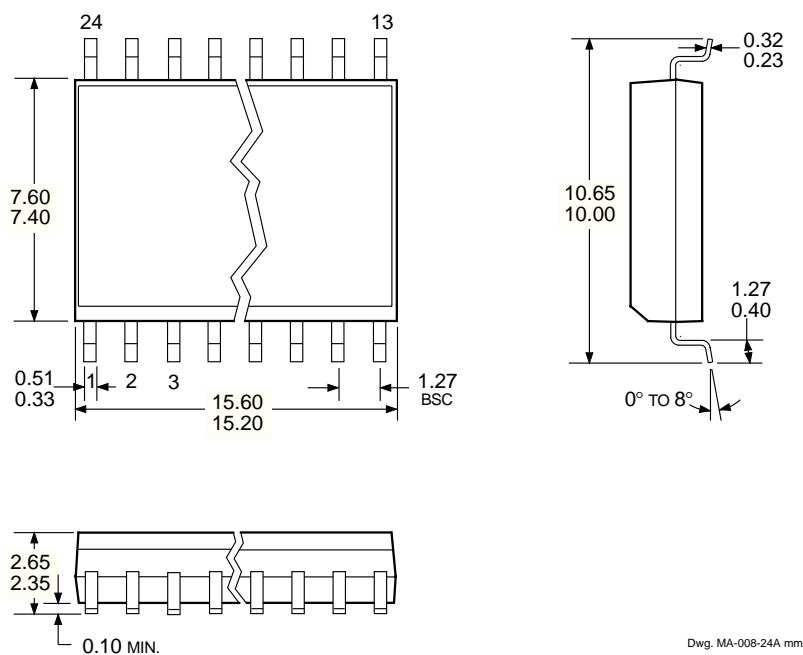

- NOTES: 1. Exact body and lead configuration at vendor's option within limits shown.  
2. Lead spacing tolerance is non-cumulative.

**5800 AND 5801**  
*BiMOS II*  
*LATCHED DRIVERS*

This page intentionally left blank

---

**5800 AND 5801**  
**BiMOS II**  
**LATCHED DRIVERS**

***BiMOS II (Series 5800) & DABiC IV (Series 6800)***  
**INTELLIGENT POWER INTERFACE DRIVERS**  
**SELECTION GUIDE**

Function	Output Ratings *		Part Number †
<b>SERIAL-INPUT LATCHED DRIVERS</b>			
8-Bit (saturated drivers)	-120 mA	50 V‡	5895
8-Bit	350 mA	50 V	5821
8-Bit	350 mA	80 V	5822
8-Bit	350 mA	50 V‡	5841
8-Bit	350 mA	80 V‡	5842
9-Bit	1.6 A	50 V	5829
10-Bit (active pull-downs)	-25 mA	60 V	5810-F and 6809/10
12-Bit (active pull-downs)	-25 mA	60 V	5811 and 6811
20-Bit (active pull-downs)	-25 mA	60 V	5812-F and 6812
32-Bit (active pull-downs)	-25 mA	60 V	5818-F and 6818
32-Bit	100 mA	30 V	5833
32-Bit (saturated drivers)	100 mA	40 V	5832
<b>PARALLEL-INPUT LATCHED DRIVERS</b>			
4-Bit	350 mA	50 V‡	5800
8-Bit	-25 mA	60 V	5815
8-Bit	350 mA	50 V‡	5801
<b>SPECIAL-PURPOSE FUNCTIONS</b>			
Unipolar Stepper Motor Translator/Driver	1.25 A	50 V‡	5804
Addressable 28-Line Decoder/Driver	450 mA	30 V	6817

\* Current is maximum specified test condition, voltage is maximum rating. See specification for sustaining voltage limits. Negative current is defined as coming out of (sourcing) the output.

† Complete part number includes additional characters to indicate operating temperature range and package style.

‡ Internal transient-suppression diodes included for inductive-load protection.

*Allegro MicroSystems, Inc. reserves the right to make, from time to time, such departures from the detail specifications as may be required to permit improvements in the design of its products.*

*The information included herein is believed to be accurate and reliable. However, Allegro MicroSystems, Inc. assumes no responsibility for its use, nor for any infringements of patents or other rights of third parties which may result from its use.*