



May 1999

LM161/LM261/LM361 High Speed Differential Comparators

General Description

The LM161/LM261/LM361 is a very high speed differential input, complementary TTL output voltage comparator with improved characteristics over the SE529/NE529 for which it is a pin-for-pin replacement. The device has been optimized for greater speed performance and lower input offset voltage. Typically delay varies only 3 ns for over-drive variations of 5 mV to 500 mV. It may be operated from op amp supplies ($\pm 15V$).

Complementary outputs having maximum skew are provided. Applications involve high speed analog to digital converters and zero-crossing detectors in disk file systems.

Features

- Independent strobes
- Guaranteed high speed: 20 ns max
- Tight delay matching on both outputs
- Complementary TTL outputs
- Operates from op amp supplies: $\pm 15V$
- Low speed variation with overdrive variation
- Low input offset voltage
- Versatile supply voltage range

Connection Diagrams

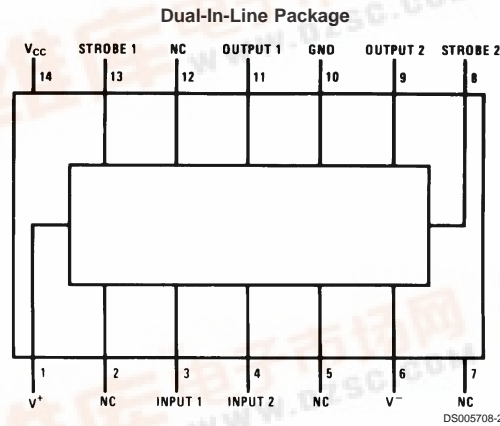

Top View
Order Number LM161J
LM361M or LM361N
See NS Package Number M14A or N14A

Note 1: Also available per SMD #5962-8757203

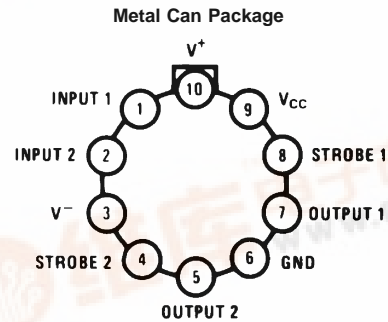

Order Number LM161H/883 (Note 1), or LM361H
See NS Package Number H10C

LM161/LM261/LM361 High Speed Differential Comparators



Logic Diagram

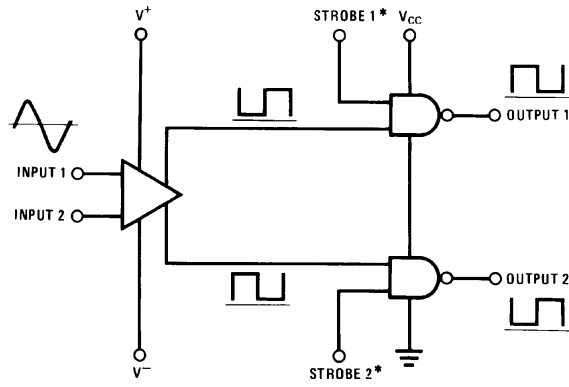

*Output is low when current is drawn from strobe pin.

DS005708-4

Absolute Maximum Ratings (Note 2)

If Military/Aerospace specified devices are required, please contact the National Semiconductor Sales Office/Distributors for availability and specifications.

Positive Supply Voltage, V^+	+16V
Negative Supply Voltage, V^-	-16V
Gate Supply Voltage, V_{CC}	+7V
Output Voltage	+7V
Differential Input Voltage	$\pm 5V$
Input Common Mode Voltage	$\pm 6V$
Power Dissipation	600 mW
Storage Temperature Range	-65°C to +150°C
Operating Temperature Range	T_{MIN} T_{MAX}
LM161	-55°C to +125°C
LM261	-25°C to +85°C
LM361	0°C to +70°C
Lead Temp. (Soldering, 10 seconds)	260°C
For Any Device Lead Below V^-	0.3V

Operating Conditions

	Min	Typ	Max
Supply Voltage V^+			
LM161/LM261	5V		15V
LM361	5V		15V
Supply Voltage V^-			
LM161/LM261	-6V		-15V
LM361	-6V		-15V
Supply Voltage V_{CC}			
LM161/LM261	4.5V	5V	5.5V
LM361	4.75V	5V	5.25V
ESD Tolerance (Note 6)			1600V
Soldering Information			
Dual-In-Line Package			
Soldering (10 seconds)			260°C
Small Outline Package			
Vapor Phase (60 seconds)			215°C
Infrared (15 seconds)			220°C

See AN-450 "Surface Mounting Methods and Their Effect on Product Reliability" for other methods of soldering surface mount devices.

Electrical Characteristics

($V^+ = +10V$, $V_{CC} = +5V$, $V^- = -10V$, $T_{MIN} \leq T_A \leq T_{MAX}$, unless noted)

Parameter	Conditions	Limits						Units
		LM161/LM261			LM361			
		Min	Typ	Max	Min	Typ	Max	
Input Offset Voltage			1	3		1	5	mV
Input Bias Current	$T_A = 25^\circ C$		5	20		10	30	μA
Input Offset Current	$T_A = 25^\circ C$		2	3		2	5	μA
Voltage Gain	$T_A = 25^\circ C$		3			3		V/mV
Input Resistance	$T_A = 25^\circ C$, $f = 1$ kHz		20			20		k Ω
Logical "1" Output Voltage	$V_{CC} = 4.75V$, $I_{SOURCE} = -0.5$ mA	2.4	3.3		2.4	3.3		V
Logical "0" Output Voltage	$V_{CC} = 4.75V$, $I_{SINK} = 6.4$ mA			0.4			0.4	V
Strobe Input "1" Current (Output Enabled)	$V_{CC} = 5.25V$, $V_{STROBE} = 2.4V$			200			200	μA
Strobe Input "0" Current (Output Disabled)	$V_{CC} = 5.25V$, $V_{STROBE} = 0.4V$			-1.6			-1.6	mA
Strobe Input "0" Voltage	$V_{CC} = 4.75V$			0.8			0.8	V
Strobe Input "1" Voltage	$V_{CC} = 4.75V$	2			2			V
Output Short Circuit Current	$V_{CC} = 5.25V$, $V_{OUT} = 0V$	-18		-55	-18		-55	mA
Supply Current I^+	$V^+ = 10V$, $V^- = -10V$, $V_{CC} = 5.25V$, $-55^\circ C \leq T_A \leq 125^\circ C$			4.5				mA
Supply Current I^+	$V^+ = 10V$, $V^- = -10V$, $V_{CC} = 5.25V$, $0^\circ C \leq T_A \leq 70^\circ C$						5	mA
Supply Current I^-	$V^+ = 10V$, $V^- = -10V$, $V_{CC} = 5.25V$, $-55^\circ C \leq T_A \leq 125^\circ C$			10				mA

Electrical Characteristics (Continued)

($V^+ = +10V$, $V_{CC} = +5V$, $V^- = -10V$, $T_{MIN} \leq T_A \leq T_{MAX}$, unless noted)

Parameter	Conditions	Limits						Units
		LM161/LM261			LM361			
		Min	Typ	Max	Min	Typ	Max	
Supply Current I^-	$V^+ = 10V$, $V^- = -10V$, $V_{CC} = 5.25V$, $0^\circ C \leq T_A \leq 70^\circ C$						10	mA
Supply Current I_{CC}	$V^+ = 10V$, $V^- = -10V$, $V_{CC} = 5.25V$, $-55^\circ C \leq T_A \leq 125^\circ C$			18				mA
Supply Current I_{CC}	$V^+ = 10V$, $V^- = -10V$, $V_{CC} = 5.25V$, $0^\circ C \leq T_A \leq 70^\circ C$						20	mA
Transient Response	$V_{IN} = 50$ mV overdrive (Note 4)							
Propagation Delay Time ($t_{pd(0)}$)	$T_A = 25^\circ C$		14	20		14	20	ns
Propagation Delay Time ($t_{pd(1)}$)	$T_A = 25^\circ C$		14	20		14	20	ns
Delay Between Output A and B	$T_A = 25^\circ C$		2	5		2	5	ns
Strobe Delay Time ($t_{pd(0)}$)	$T_A = 25^\circ C$		8			8		ns
Strobe Delay Time ($t_{pd(1)}$)	$T_A = 25^\circ C$		8			8		ns

Note 2: The device may be damaged by use beyond the maximum ratings.

Note 3: Typical thermal impedances are as follows:

	H Package	J Package	N Package
θ_{JA}	165°C/W (Still Air) 67°C/W (400 LF/Min Air Flow)	112°C/W	105°C/W
θ_{JC}	25°C/W		

DS005708-17

Note 4: Measurements using AC Test circuit, Fanout = 1. The devices are faster at low supply voltages.

Note 5: Refer to RETS161X for LM161H and LM161J military specifications.

Note 6: Human body model, 1.5 k Ω in series with 100 pF.

Typical Performance Characteristics

Offset Voltage

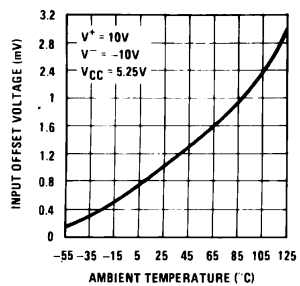

Input Currents vs Ambient Temperature

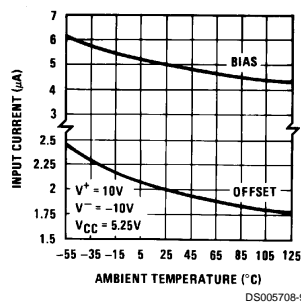

Input Characteristics

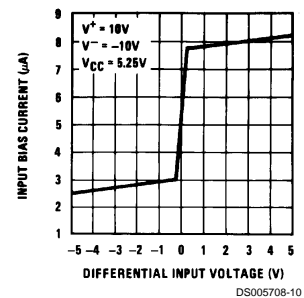

Typical Performance Characteristics (Continued)

Supply Current vs Ambient Temperature

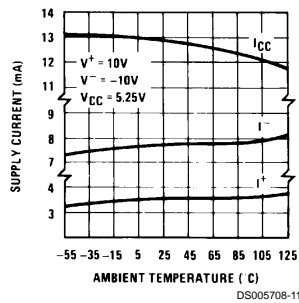

Supply Current vs Supply Voltage

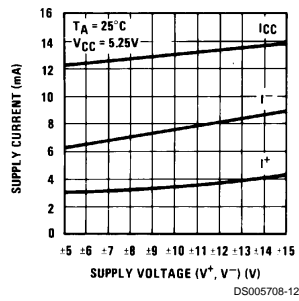

Propagation Delay vs Ambient Temperature

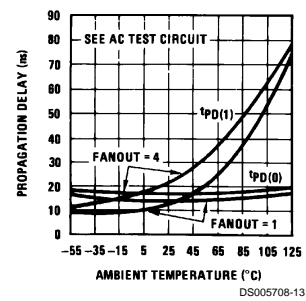

Delay of Output 1 With Respect to Output 2 vs Ambient Temperature

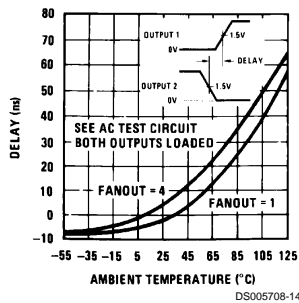

Strobe Delay vs Ambient Temperature

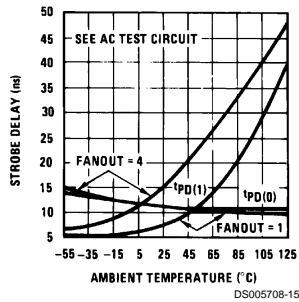

Common-Mode Pulse Response

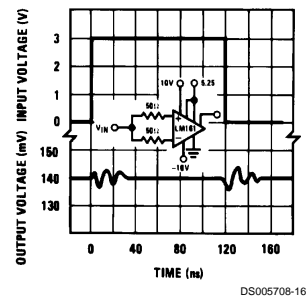

Propagation Delay vs Supply Voltage

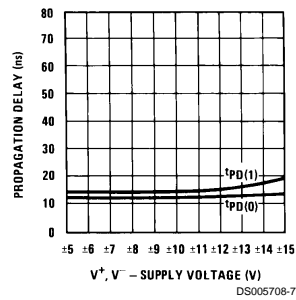

AC Test Circuit

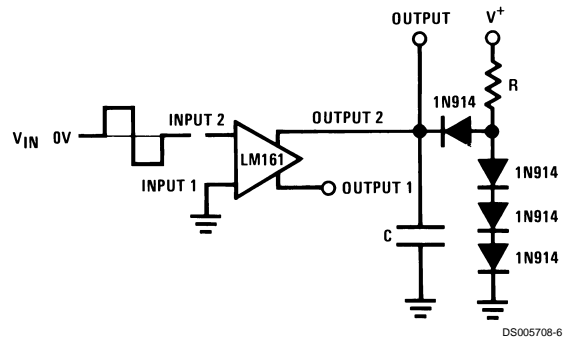

$V_{IN} = \pm 50 \text{ mV}$ FANOUT = 1 FANOUT = 4
 $V^+ = +10\text{V}$ $R = 2.4\text{k}$ $R = 680\Omega$
 $V^- = -10\text{V}$ $C = 15 \text{ pF}$ $C = 30 \text{ pF}$
 $V_{CC} = 5.25\text{V}$

Schematic Diagram

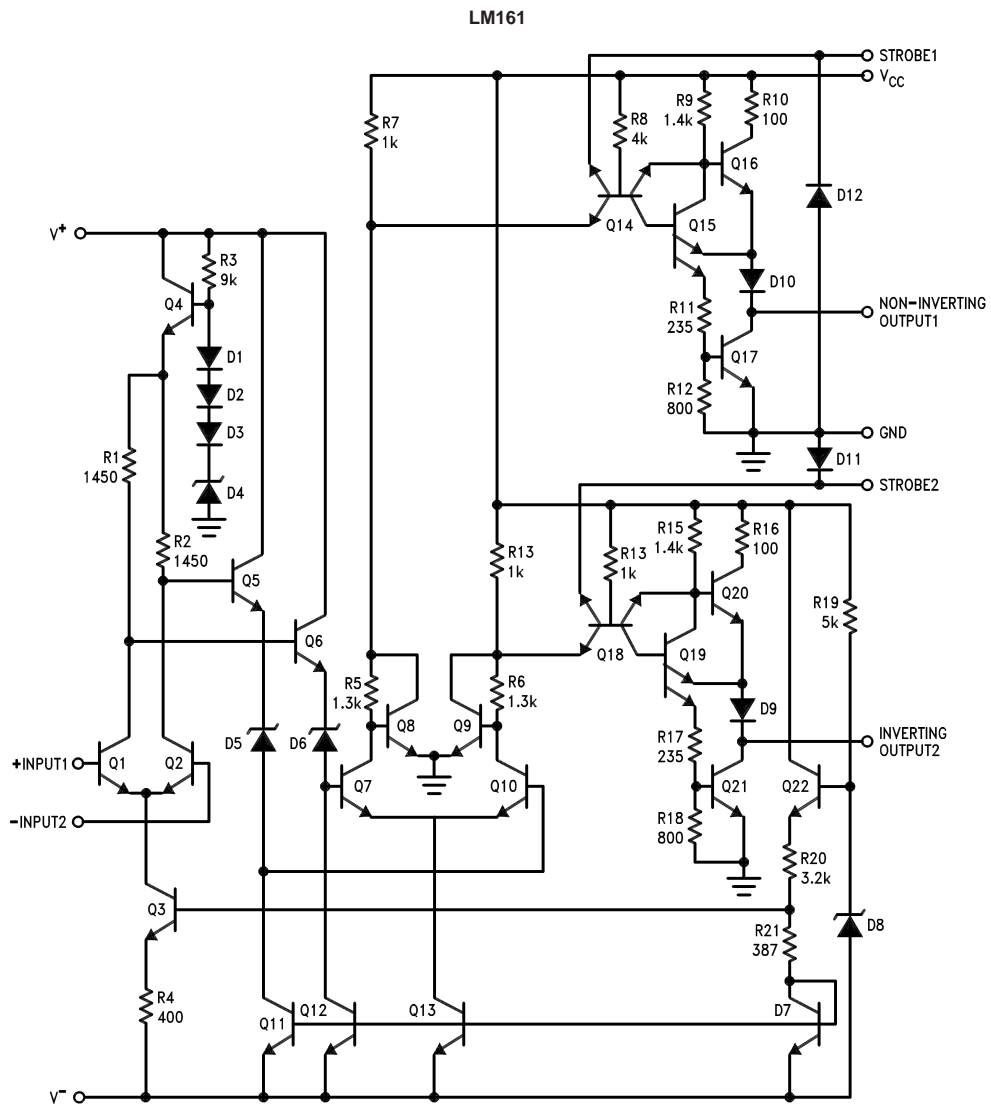

R10, R16: 85
R11, R17: 205

DS005708-1

Physical Dimensions inches (millimeters) unless otherwise noted

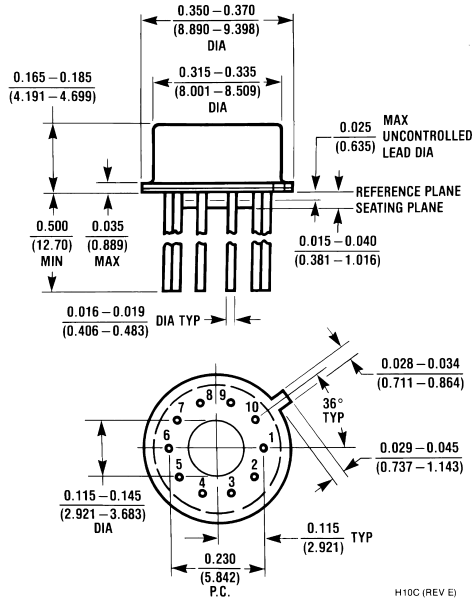

Metal Can Package (H)
Order Number LM161H/883, or LM361H
NS Package Number H10C

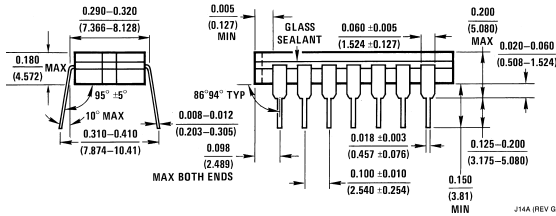
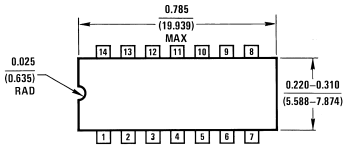

Ceramic Dual-In-Line Package (J)
Order Number LM161J
NS Package Number J14A

Physical Dimensions inches (millimeters) unless otherwise noted (Continued)

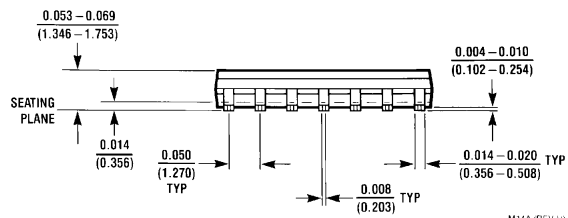
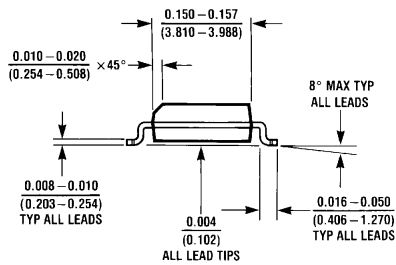
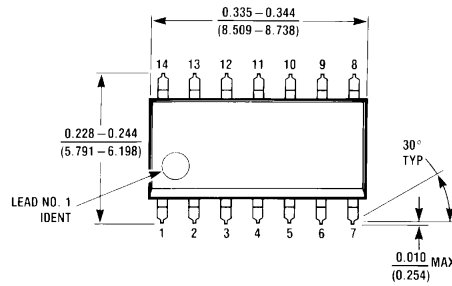

M14A (REV H)

**Order Number LM361M
NS Package Number M14A**

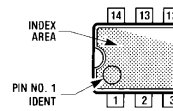
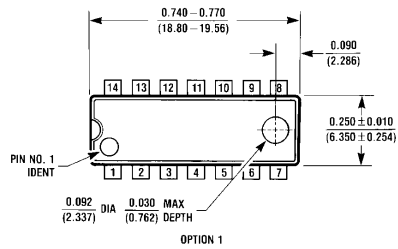

OPTION 02

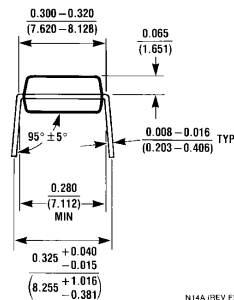
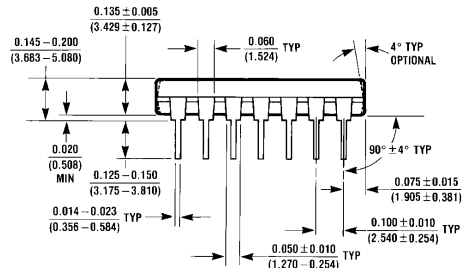

N14A (REV F)

**Molded Dual-In-Line Package (N)
Order Number LM361N
NS Package Number N14A**

Notes

LIFE SUPPORT POLICY

NATIONAL'S PRODUCTS ARE NOT AUTHORIZED FOR USE AS CRITICAL COMPONENTS IN LIFE SUPPORT DEVICES OR SYSTEMS WITHOUT THE EXPRESS WRITTEN APPROVAL OF THE PRESIDENT AND GENERAL COUNSEL OF NATIONAL SEMICONDUCTOR CORPORATION. As used herein:

1. Life support devices or systems are devices or systems which, (a) are intended for surgical implant into the body, or (b) support or sustain life, and whose failure to perform when properly used in accordance with instructions for use provided in the labeling, can be reasonably expected to result in a significant injury to the user.
2. A critical component is any component of a life support device or system whose failure to perform can be reasonably expected to cause the failure of the life support device or system, or to affect its safety or effectiveness.



National Semiconductor Corporation
Americas
Tel: 1-800-272-9959
Fax: 1-800-737-7018
Email: support@nsc.com

www.national.com

National Semiconductor Europe

Fax: +49 (0) 1 80-530 85 86
Email: europe.support@nsc.com
Deutsch Tel: +49 (0) 1 80-530 85 85
English Tel: +49 (0) 1 80-532 78 32
Français Tel: +49 (0) 1 80-532 93 58
Italiano Tel: +49 (0) 1 80-534 16 80

National Semiconductor Asia Pacific Customer Response Group

Tel: 65-2544466
Fax: 65-2504466
Email: sea.support@nsc.com

National Semiconductor Japan Ltd.

Tel: 81-3-5639-7560
Fax: 81-3-5639-7507