



MC34063A

DC/DC CONVERTER CONTROL CIRCUIT

SPEC NO: DS34063A-00

FEATURES

- 3V to 30V Input Voltage Operation.
- Internal 1.6A Peak Current Switch.
- Internal $\pm 1.8\%$ Reference.
- Low Quiescent Current at 1.6mA.
- Frequency Operation from 100Hz to 100KHz.
- Current Limiting.

APPLICATIONS

- Saver for Cellular phones
- DC-DC Converter Module

DESCRIPTION

The MC34063A by Analog Integrations Corporation, an improved second source over the industrial standard MC34063A, is a monolithic control circuit containing the primary functions required for DC/DC converters. The device consists of an internal temperature compensated reference, comparator, controlled duty cycle oscillator with an active current limit circuit, driver and high current output switch. This device is specifically designed to be incorporated in step-down, step-up and voltage-inverting applications with a minimum number of external components. The $\pm 1.8\%$ internal reference and low quiescent current of 1.6mA are among the improvements of the device over the competition.

TYPICAL APPLICATION CIRCUIT

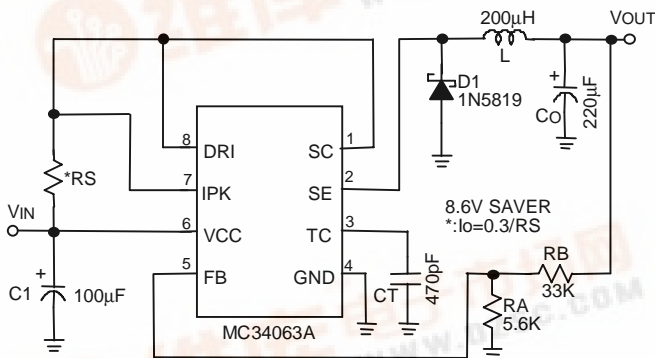

Saver Circuit for Cellular Phone

ORDERING INFORMATION

MC34063A XX

PACKAGE TYPE
N: PLASTIC DIP
S: SMALL OUTLINE

TEMPERATURE
C: 0°C~+70°C

| ORDER NUMBER | PIN CONFIGURATION |
|-----------------------------|-------------------|
| MC34063ACN (PLASTIC DIP) | TOP VIEW |
| MC34063ACS (PLASTIC SO) | |





■ **ABSOLUTE MAXIMUM RATINGS**

| | |
|-------------------------------------|-----------|
| Supply Voltage | 30V |
| Comparator Input Voltage Range | -0.3V~30V |
| Switch Collector Voltage | 30V |
| Switch Emitter Voltage | 30V |
| Switch Collector to Emitter Voltage | 30V |
| Driver Collector Voltage | 30V |
| Switch Current | 1.6A |

Power Dissipation and Thermal Characteristics

DIP Package

| | |
|--------------------|----------|
| Ta= 25°C | 1.0W |
| Thermal Resistance | 100°C /W |

SO Package

| | |
|--------------------|----------|
| Ta= 25°C | 625mW |
| Thermal Resistance | 160°C /W |

| | |
|-------------------------------------|--------------|
| Operating Junction Temperature | 125°C |
| Operating Ambient Temperature Range | 0°C~70°C |
| Storage Temperature Range | - 65°C~150°C |



■ ELECTRICAL CHARACTERISTICS (VCC= 5V, Ta=25°C, unless otherwise specified.)

| PARAMETER | TEST CONDITIONS | SYMBOL | MIN. | TYP. | MAX. | UNIT |
|---|--|--|-------|------|-------|------|
| Oscillator | | | | | | |
| Charging Current | 5.0V≤VCC≤30V | I _{CHG} | 10 | 25 | 40 | μA |
| Discharge Current | 5.0V≤VCC≤30V | I _{DISCHG} | 100 | 150 | 200 | μA |
| Voltage Swing | PIN 3 | V _{OSC} | | 0.6 | | V |
| Discharge to Charge Current Ratio | V _{IPK(SENSE)} =VCC | I _{DISCHG} / I _{CHG} | | 6.0 | | |
| Current Limit Sense Voltage | I _{CHG} =I _{DISCHG} | V _{IPK(SENSE)} | 250 | 300 | 350 | mV |
| Output Switch | | | | | | |
| Saturation Voltage, Darlington Connection | I _{SW} =1.0A; V _{C(DRIVER)} =V _{C(SWITCH)} | V _{CE(SAT)} | | 1.0 | 1.3 | V |
| Saturation Voltage | I _{SW} =1.0A; I _{C(DRIVER)} =50mA (Forced β≈20) | V _{CE(SAT)} | | 0.4 | 0.7 | V |
| DC Current Gain | I _{SW} =1.0A; V _{CE} =5.0V | h _{FE} | 35 | 120 | | |
| Collector Off-State Current | V _{CE} =30V | I _{C(OFF)} | | 10 | | nA |
| Comparator | | | | | | |
| Threshold Voltage | 0°C≤Ta≤70°C | V _{FB} | 1.227 | 1.25 | 1.273 | V |
| Threshold Voltage | | | 1.21 | | 1.29 | V |
| Threshold Voltage Line Regulation | 3.0V≤VCC≤30V | REG _{LINE} | | 0.1 | 0.3 | mV/V |
| Input Bias Current | V _{IN} =0V | I _{IB} | | 0.4 | 1 | μA |
| Supply current | V _{IPK(SENSE)} =VCC V _{PIN 5} >V _{FB} 5.0V≤VCC≤30V C _T =0.001μF, PIN 2=GND Remaining pins open | I _{CC} | | 1.6 | 3 | mA |



TYPICAL PERFORMANCE CHARACTERISTICS

Output Switch ON-OFF Time vs. Oscillator Timing Capacitor

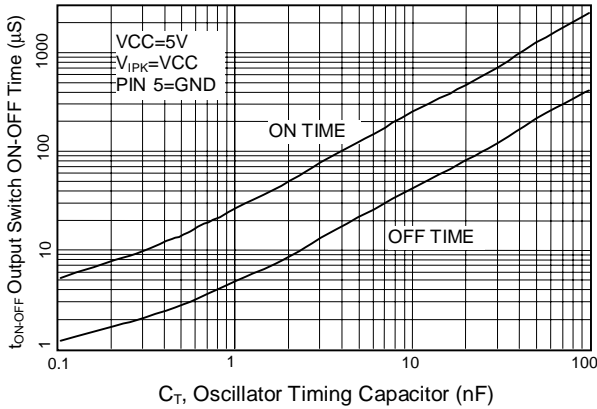

Standby Supply Current vs. Supply Voltage

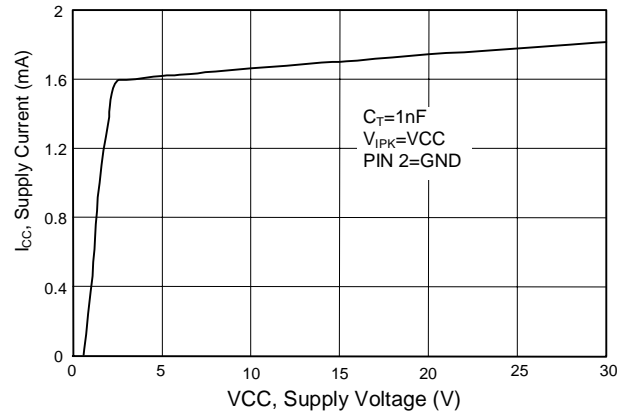

VFB, Threshold Voltage vs Temperature

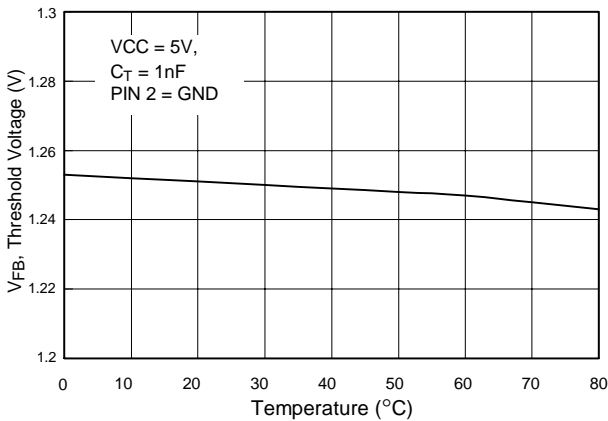

IPK Threshold Voltage vs Temperature

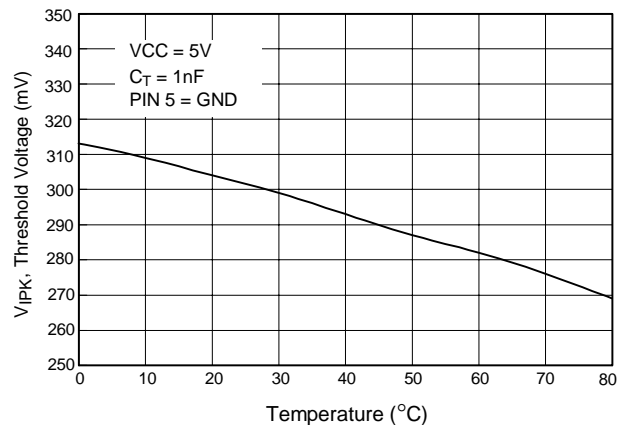

Emmitter-Follower Configuration Output Switch Saturation Voltage vs Emmitter Current

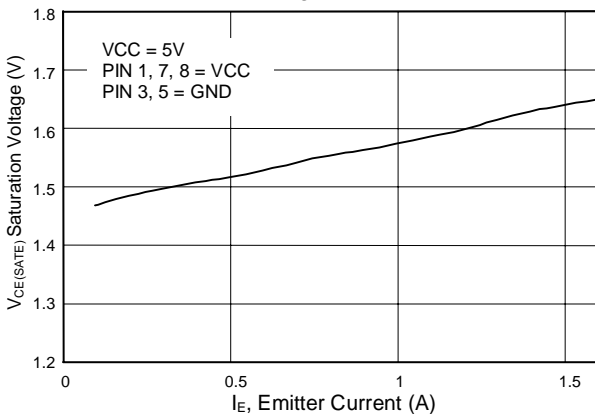

Common-Emitter Configuration Output Switch Saturation Voltage vs Collector Current

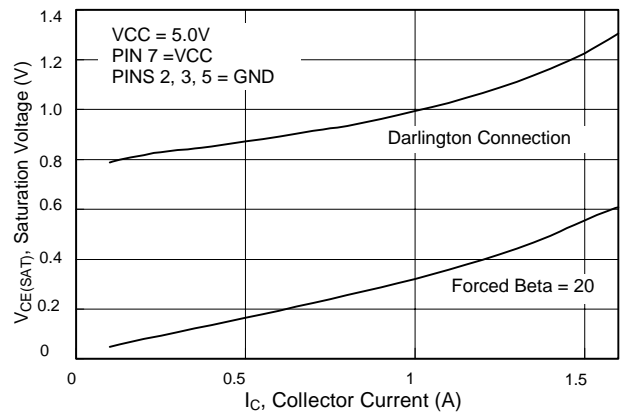



BLOCK DIAGRAM

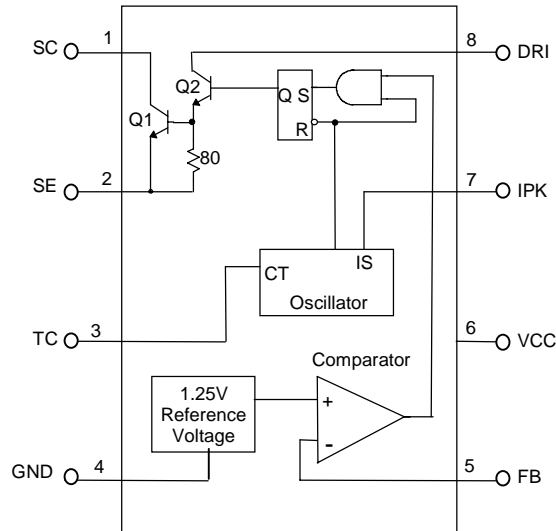

PIN DESCRIPTIONS

- PIN 1: SC - 1.6A switch collector
- PIN 2: SE - Darlington switch emitter
- PIN 3: TC - Oscillator timing capacitor
- PIN 4: GND - Power GND
- PIN 5: FB - Feedback comparator inverting input
- PIN 6: VCC - Power supply input
- PIN 7: IPK - Highside current sense input, VCC - V_{IPK}=300mV
- PIN 8: DRI - Drive collector

APPLICATION INFORMATION

DESIGN FORMULA TABLE

| CALCULATION | STEP-DOWN | STEP-UP | VOLTAGE-INVERTING |
|----------------------------|--|--|--|
| $\frac{t_{ON}}{t_{OFF}}$ | $\frac{V_{OUT} + V_F}{V_{IN(MIN)} - V_{SAT} - V_{OUT}}$ | $\frac{V_{OUT} + V_F - V_{IN(MIN)}}{V_{IN(MIN)} - V_{SAT}}$ | $\frac{ V_{OUT} + V_F}{V_{IN} - V_{SAT}}$ |
| $(t_{ON} + t_{OFF})_{MAX}$ | $\frac{1}{F_{MIN}}$ | $\frac{1}{F_{MIN}}$ | $\frac{1}{F_{MIN}}$ |
| C _T | $4 \times 10^{-5} t_{ON}$ | $4 \times 10^{-5} t_{ON}$ | $4 \times 10^{-5} t_{ON}$ |
| I _{C(SWITCH)} | $2 I_{OUT(MAX)}$ | $2 I_{OUT(MAX)} \left(\frac{t_{ON} + t_{OFF}}{t_{OFF}} \right)$ | $2 I_{OUT(MAX)} \left(\frac{t_{ON} + t_{OFF}}{t_{OFF}} \right)$ |
| RS | $0.33 / I_{C(SWITCH)}$ | $0.33 / I_{C(SWITCH)}$ | $0.33 / I_{C(SWITCH)}$ |
| L(MIN) | $\left(\frac{V_{IN(MIN)} - V_{SAT} - V_{OUT}}{I_{C(SWITCH)}} \right) t_{ON(MAX)}$ | $\left(\frac{V_{IN(MIN)} - V_{SAT}}{I_{C(SWITCH)}} \right) t_{ON(MAX)}$ | $\left(\frac{V_{IN(MIN)} - V_{SAT}}{I_{C(SWITCH)}} \right) t_{ON(MAX)}$ |
| Co | $\frac{I_{C(SWITCH)} (t_{ON} + t_{OFF})}{8 V_{RIPPLE(P-P)}}$ | $\frac{I_{OUT} t_{ON}}{V_{RIPPLE(P-P)}}$ | $\frac{I_{OUT} t_{ON}}{V_{RIPPLE(P-P)}}$ |



V_{SAT} = Saturation voltage of the output switch.
 V_F = Forward voltage drop of the ringback rectifier

F_{MIN} - Minimum desired output switching frequency at the selected values for V_{IN} and I_{OUT} .

The following power supply characteristics must be chosen:

- V_{IN} - Nominal input voltage.
- V_{OUT} - Desired output voltage,
 $|V_{OUT}| = 1.25 (1 + RB/RA)$
- I_{OUT} - Desired output current.

$V_{RIPPLE (P-P)}$ - Desired peak-to-peak output ripple voltage. In practice, the calculated value will need to be increased due to the capacitor equivalent series resistance and board layout. The ripple voltage should be kept to a low value since it will directly effect the line and load regulation.

APPLICATION EXAMPLES

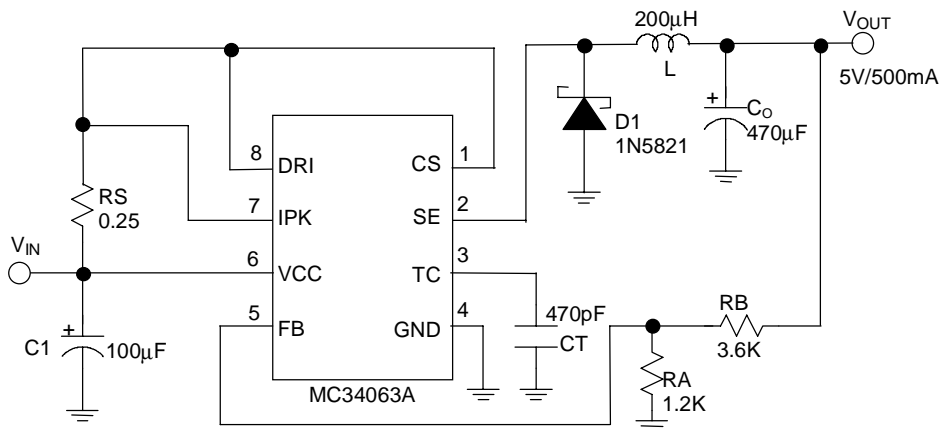

| | | |
|-----------------------|---|------|
| Line Regulation | $V_{IN} = 10V \sim 20V @ I_O = 500mA$ | 40mV |
| Load Regulation | $V_{IN} = 15V, @ I_O = 10mA \sim 500mA$ | 5mV |
| Short Circuit Current | $V_{IN} = 15V, @ R_L = 0.1\Omega$ | 1.3A |

Fig. 1 Step-Down Converter

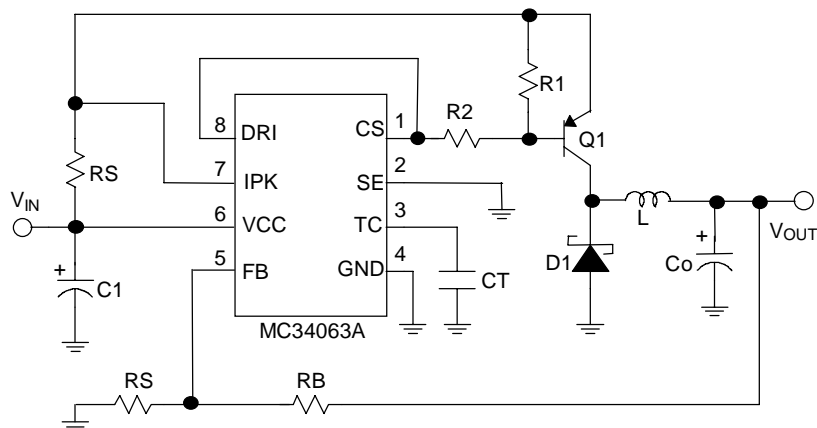
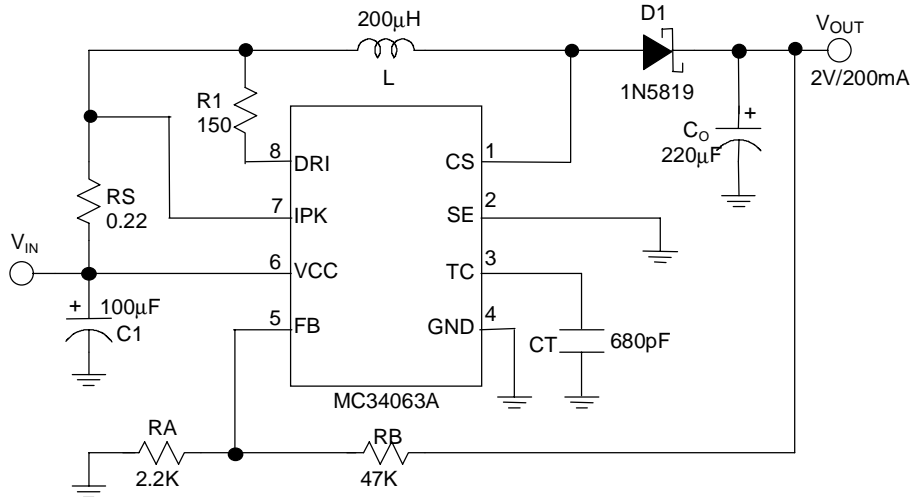

Fig. 2 Step-Down Converter with External PNP Saturation Switch



APPLICATION EXAMPLES (CONTINUED)



| | | |
|-----------------|---------------------------------------|-------|
| Line Regulation | $V_{IN} = 8V \sim 16V @ I_O=200mA$ | 100mV |
| Load Regulation | $V_{IN} = 12V, @ I_O=80mA \sim 200mA$ | 5mV |

Fig. 3 Step-Up Converter

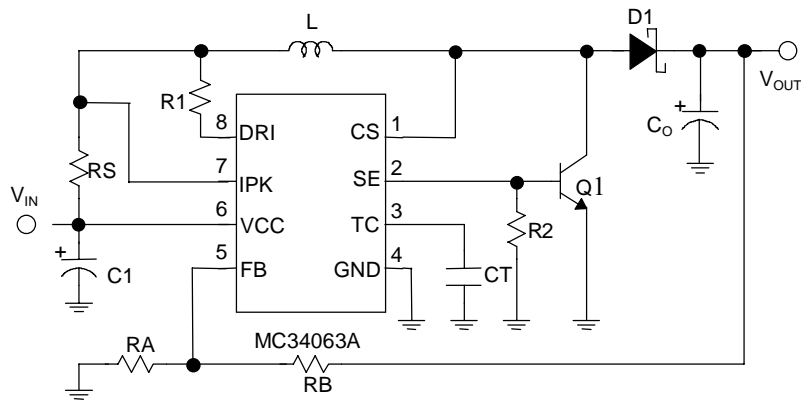
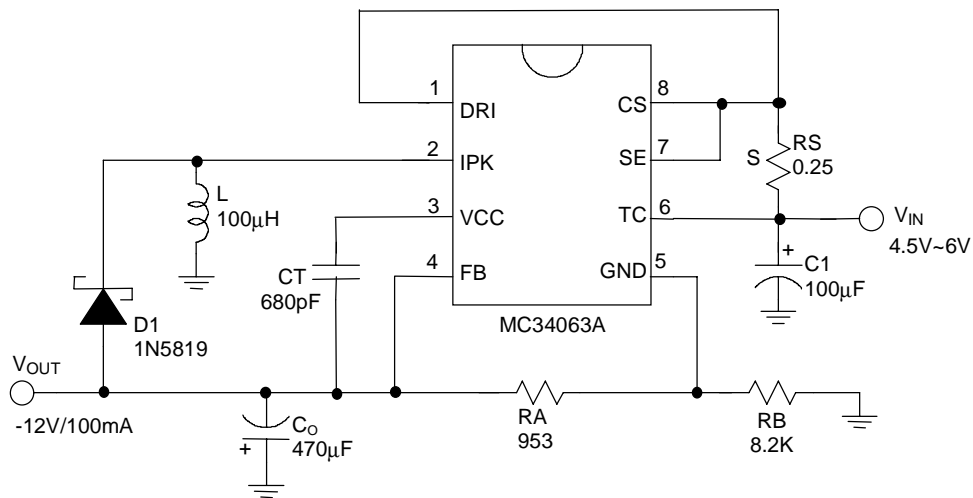

Fig. 4 Step-Up Converter with External NPN Switch



■ APPLICATION EXAMPLES (CONTINUED)



| | | |
|-----------------|--|-------|
| Line Regulation | $V_{IN} = 4.5V \sim 6V @ I_O = 100mA$ | 20mV |
| Load Regulation | $V_{IN} = 5V, @ I_O = 10mA \sim 100mA$ | 100mV |

Fig.5 Inverting Converter

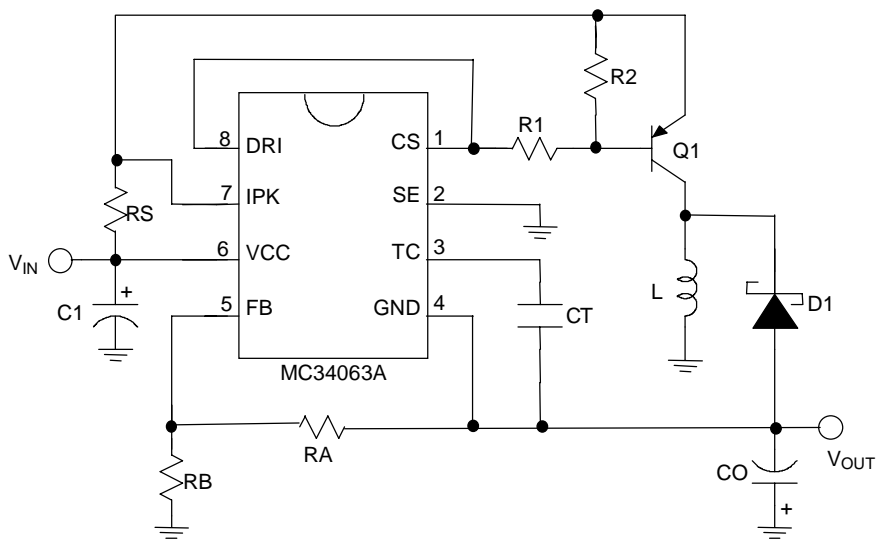
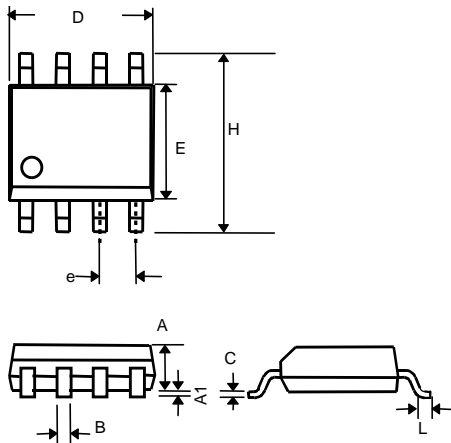

Fig 6. Voltage Inverting Converter With PNP Saturated Switch



PHYSICAL DIMENSIONS

● 8 LEAD PLASTIC SO (unit: mm)



| SYMBOL | MIN | MAX |
|--------|-----------|------|
| A | 1.35 | 1.75 |
| A1 | 0.10 | 0.25 |
| B | 0.33 | 0.51 |
| C | 0.19 | 0.25 |
| D | 4.80 | 5.00 |
| E | 3.80 | 4.00 |
| e | 1.27(TYP) | |
| H | 5.80 | 6.20 |
| L | 0.40 | 1.27 |

● 8 LEAD PLASTIC DIP (unit: mm)

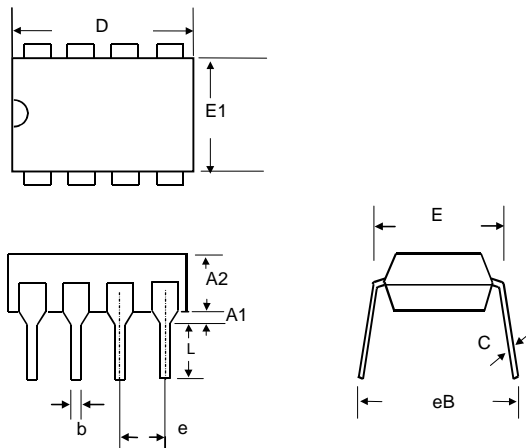

| SYMBOL | MIN | MAX |
|--------|------------|-------|
| A1 | 0.381 | — |
| A2 | 2.92 | 4.96 |
| b | 0.35 | 0.56 |
| C | 0.20 | 0.36 |
| D | 9.01 | 10.16 |
| E | 7.62 | 8.26 |
| E1 | 6.09 | 7.12 |
| e | 2.54 (TYP) | |
| eB | — | 10.92 |
| L | 2.92 | 3.81 |