

TOSHIBA CMOS DIGITAL INTEGRATED CIRCUIT SILICON MONOLITHIC

TC74HC4066AP, TC74HC4066AF, TC74HC4066AFN, TC74HC4066AFT

QUAD BILATERAL SWITCH

The TC74HC4066A is a high speed CMOS QUAD BILATERAL SWITCH fabricated with silicon gate C²MOS technology.

It consists of four independent high speed switches capable of controlling either digital or analog signals while maintaining the CMOS low power dissipation.

Control input (C) is provided to control the switch. The switch turns ON while the C input is high, and the switch turns OFF while low.

All inputs are equipped with protection circuits against static discharge or transient excess voltage.

FEATURES:

- High Speed $t_{pd} = 7\text{ns}(\text{typ.})$ at $V_{CC} = 5\text{V}$
- Low Power Dissipation $I_{CC} = 1\mu\text{A}(\text{Max.})$ at $T_a = 25^\circ\text{C}$
- High Noise Immunity $V_{NIH} = V_{NIL} = 28\% V_{CC} (\text{Min.})$
- Low ON Resistance $R_{ON} = 50\Omega(\text{typ.})$ at $V_{CC} = 9\text{V}$
- High Degree of Linearity $\text{THD} = 0.05\%(\text{typ.})$ at $V_{CC} = 5\text{V}$
- Pin and Function Compatible with 4066B

(Note) The JEDEC SOP (FN) is not available in Japan.

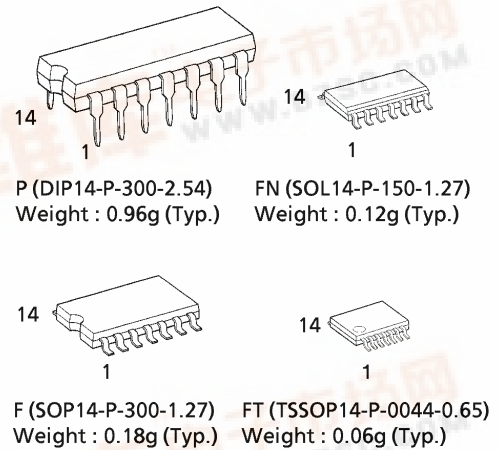

PIN ASSIGNMENT

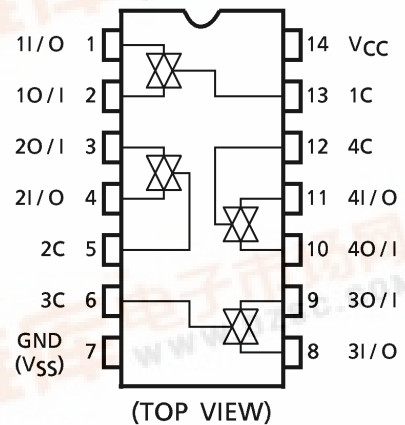

IEC LOGIC SYMBOL

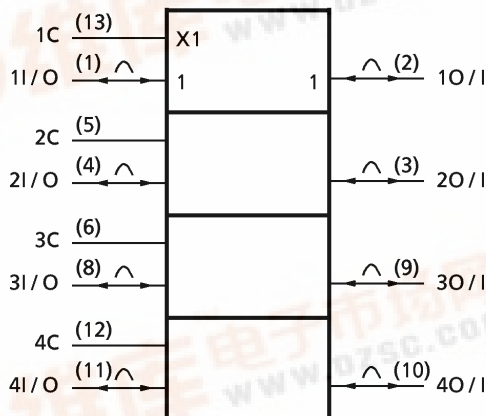

TRUTH TABLE

CONTROL	SWITCH FUNCTION
H	ON
L	OFF

980508EBA2

● TOSHIBA is continually working to improve the quality and the reliability of its products. Nevertheless, semiconductor devices in general can malfunction or fail due to their inherent electrical sensitivity and vulnerability to physical stress. It is the responsibility of the buyer, when utilizing TOSHIBA products, to observe standards of safety, and to avoid situations in which a malfunction or failure of a TOSHIBA product could cause loss of human life, bodily injury or damage to property. In developing your designs, please ensure that TOSHIBA products are used within specified operating ranges as set forth in the most recent products specifications. Also, please keep in mind the precautions and conditions set forth in the TOSHIBA Semiconductor Reliability Handbook.



ABSOLUTE MAXIMUM RATINGS

PARAMETER	SYMBOL	VALUE	UNIT
Supply Voltage Range	V_{CC}	-0.5~13	V
Control Input Voltage	V_{IN}	-0.5~ $V_{CC} + 0.5$	V
Switch I/O Voltage	$V_{I/O}$	-0.5~ $V_{CC} + 0.5$	V
Control Input Diode Current	I_{IK}	±20	mA
I/O Diode Current	I_{OK}	±20	mA
Switch through Current	I_{OUT}	±25	mA
DC V_{CC} /Ground Current	I_{CC}	±50	mA
Power Dissipation	P_D	500 (DIP)* / 180 (SOP / TSSOP)	mW
Storage Temperature	T_{stg}	-65~150	°C

*500mW in the range of $T_a = -40^{\circ}\text{C} \sim 65^{\circ}\text{C}$. From $T_a = 65^{\circ}\text{C}$ to 85°C a derating factor of $-10\text{mW}/^{\circ}\text{C}$ shall be applied until 300mW.

RECOMMENDED OPERATING CONDITIONS

PARAMETER	SYMBOL	VALUE	UNIT
Supply Voltage	V_{CC}	2~12	V
Control Input Voltage	V_{IN}	0~ V_{CC}	V
Switch I/O Voltage	$V_{I/O}$	0~ V_{CC}	V
Operating Temperature	T_{opr}	-40~85	°C
Input Rise and Fall Time	t_r, t_f	0~1000 ($V_{CC} = 2.0\text{V}$) 0~500 ($V_{CC} = 4.5\text{V}$) 0~400 ($V_{CC} = 6.0\text{V}$) 0~250 ($V_{CC} = 10.0\text{V}$)	ns

DC ELECTRICAL CHARACTERISTICS

PARAMETER	SYMBOL	TEST CONDITION	V_{CC} (V)	$T_a = 25^{\circ}\text{C}$			$T_a = -40 \sim 85^{\circ}\text{C}$		UNIT
				MIN.	TYP.	MAX.	MIN.	MAX.	
High - Level Control Input Voltage	V_{IHC}		2.0	1.50	—	—	1.50	—	V
			4.5	3.15	—	—	3.15	—	
			9.0	6.30	—	—	6.30	—	
			12.0	8.40	—	—	8.40	—	
Low - Level Control Input Voltage	V_{ILC}		2.0	—	—	0.50	—	0.50	V
			4.5	—	—	1.35	—	1.35	
			9.0	—	—	2.70	—	2.70	
			12.0	—	—	3.60	—	3.60	
ON Resistance	R_{ON}	$V_{IN} = V_{IHC}$ $V_{I/O} = V_{CC}$ to GND $I_{I/O} \leq 1\text{mA}$	4.5	—	96	170	—	200	Ω
			9.0	—	55	85	—	100	
			12.0	—	45	80	—	90	
			12.0	—	—	—	—	—	
		$V_{IN} = V_{IHC}$ $V_{I/O} = V_{CC}$ or GND $I_{I/O} \leq 1\text{mA}$	2.0	—	160	—	—	—	
			4.5	—	70	100	—	130	
			9.0	—	50	75	—	95	
			12.0	—	45	70	—	90	
Difference of ON Resistance Between Switches	ΔR_{ON}	$V_{IN} = V_{IHC}$ $V_{I/O} = V_{CC}$ to GND $I_{I/O} \leq 1\text{mA}$	4.5	—	10	—	—	—	
			9.0	—	5	—	—	—	
			12.0	—	5	—	—	—	
			12.0	—	—	—	—	—	
Input / Output Leakage Current (SWITCH OFF)	I_{OFF}	$V_{OS} = V_{CC}$ or GND $V_{IS} = \text{GND}$ or V_{CC} $V_{IN} = V_{ILC}$	12.0	—	—	±100	—	±1000	nA
			12.0	—	—	±100	—	±1000	
Switch Input Leakage Current (SWITCH ON, OUTPUT OPEN)	I_{IZ}	$V_{OS} = V_{CC}$ or GND $V_{IN} = V_{IHC}$	12.0	—	—	±100	—	±1000	nA
Control Input Current	I_{IN}	$V_{IN} = V_{CC}$ or GND	12.0	—	—	±100	—	±1000	nA
Quiescent Supply Current	I_{CC}	$V_{IN} = V_{CC}$ or GND	6.0	—	—	1.0	—	10.0	μA
			9.0	—	—	4.0	—	40.0	
			12.0	—	—	8.0	—	80.0	

980508EBA2'

- The products described in this document are subject to foreign exchange and foreign trade laws.
- The information contained herein is presented only as a guide for the applications of our products. No responsibility is assumed by TOSHIBA CORPORATION for any infringements of intellectual property or other rights of the third parties which may result from its use. No license is granted by implication or otherwise under any intellectual property or other rights of TOSHIBA CORPORATION or others.
- The information contained herein is subject to change without notice.

AC ELECTRICAL CHARACTERISTICS (C_L = 50pF, Input t_r = t_f = 6ns)

PARAMETER	SYMBOL	TEST CONDITION	Ta = 25°C			Ta = -40~85°C		UNIT	
			V _{CC} (V)	MIN.	TYP.	MAX.	MIN.		MAX.
Phase difference between Input and Output	φ _{I-O}		2.0	—	10	50	—	65	pF
			4.5	—	4	10	—	13	
			9.0	—	3	8	—	10	
			12.0	—	3	7	—	9	
Output Enable Time	t _{pZL} t _{pZH}	R _L = 1KΩ	2.0	—	18	100	—	125	
			4.5	—	8	20	—	25	
			9.0	—	6	12	—	22	
			12.0	—	6	12	—	18	
Output Disable Time	t _{pLZ} t _{pHZ}	R _L = 1KΩ	2.0	—	20	115	—	145	
			4.5	—	10	23	—	29	
			9.0	—	8	20	—	25	
			12.0	—	8	18	—	22	
Maximum Control Input Frequency		R _L = 1KΩ C _L = 15pF V _{OUT} = 1/2 V _{CC}	2.0	—	30	—	—	—	MHz
			4.5	—	30	—	—	—	
			9.0	—	30	—	—	—	
			12.0	—	30	—	—	—	
Control Input Capacitance	C _{IN}		—	5	10	—	10	pF	
Switch Terminal Capacitance	C _{I/O}		—	6	—	—	—		
Feed through Capacitance	C _{IOS}		—	0.5	—	—	—		
Power Dissipation Capacitance	C _{PD}	Note (1)	—	15	—	—	—		

Note (1) C_{PD} is defined as the value of the internal equivalent capacitance which is calculated from the operating current consumption without load.

Average operating current can be obtained by the equation :

$$I_{CC}(\text{opr}) = C_{PD} \cdot V_{CC} \cdot f_{IN} + I_{CC} / 4 \text{ (per channel)}$$

ANALOG SWITCH CHARACTERISTICS (GND = 0V, Ta = 25°C)

PARAMETER	SYMBOL	TEST CONDITION	V _{CC} (V)	TYP.	UNIT
Sine Wave Distortion (T. H. D)		f _{IN} = 1kHz R _L = 10kΩ C _L = 50pF V _{IN} = 4.0V _{P-P} V _{IN} = 8.0V _{P-P} @V _{CC} = 4.5V @V _{CC} = 9.0V	4.5 9.0	0.05 0.04	%
Frequency Response (Switch ON)	f _{MAX}	Adjust f _{IN} voltage to obtain 0dBm at V _{OS} Increase f _{IN} Frequency until dB Meter reads -3dB R _L = 50Ω, C _L = 10pF f _{IN} = 1MHz, Sine Wave	4.5 9.0	200 200	MHz
Feedthrough Attenuation (Switch OFF)		V _{in} is centered at V _{CC} /2 Adjust input for 0dBm R _L = 600Ω, C _L = 50pF f _{IN} = 1MHz, Sine Wave	4.5 9.0	-60 -60	dB
Crosstalk (Control Input to Signal Output)		R _L = 600Ω, C _L = 50pF f _{IN} = 1MHz, Square Wave (t _r = t _f = 6ns)	4.5 9.0	60 100	mV
Crosstalk (Between any switches)		Adjust V _{IN} to obtain 0dBm at Input R _L = 600Ω, C _L = 50pF f _{IN} = 1MHz, Sine Wave	4.5 9.0	-60 -60	dB

Note : These characteristics are determined by design of devices.

SWITCHING CHARACTERISTICS TEST CIRCUITS

1. t_{PLZ} , t_{PHZ} , t_{PZL} , t_{PZH}

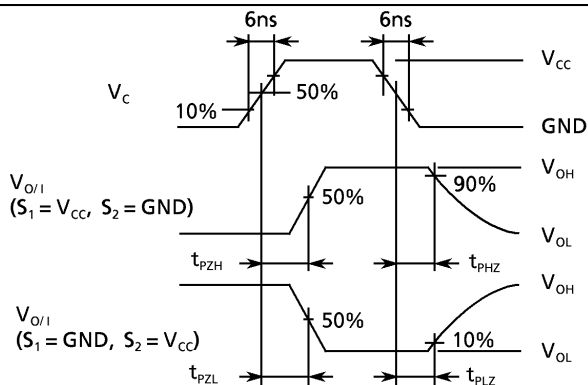
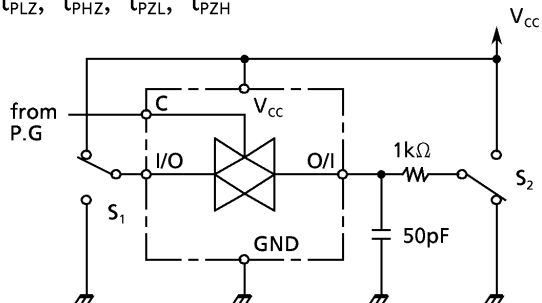

2. CROSS TALK (CONTROL INPUT-SWITCH OUTPUT)

$f_{in} = 1\text{MHz}$ duty = 50% $t_r = t_f = 6\text{ns}$

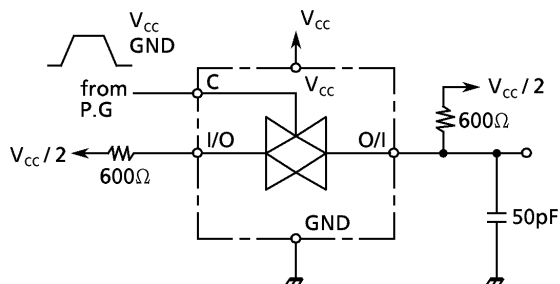

5. CROSSTALK (BETWEEN ANY TWO SWITCHES)

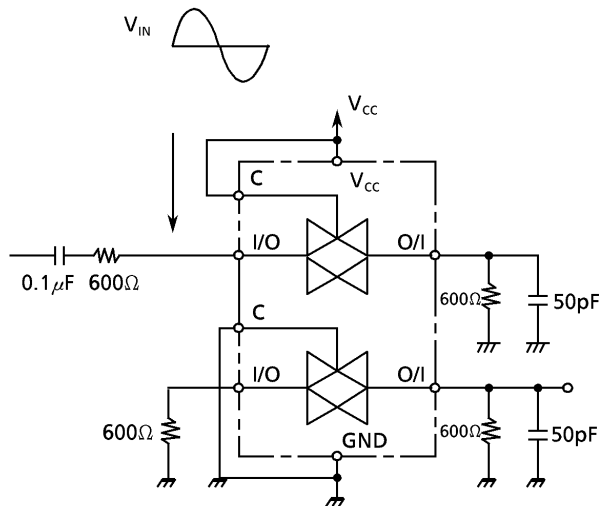

3. FEEDTHROUGH ATTENUATION

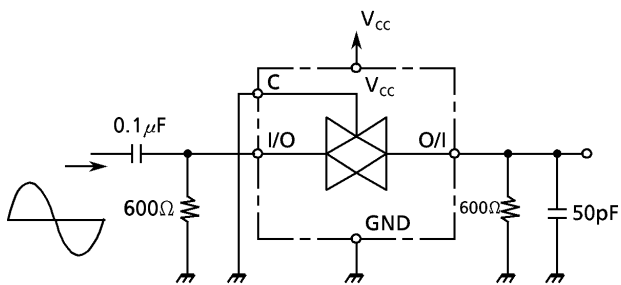

4. C_{IOS} , C_{IS} , C_{OS}

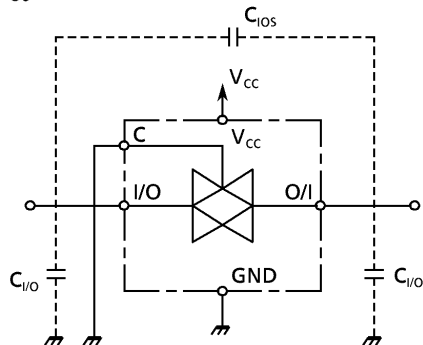

6. FREQUENCY RESPONSE (SWITCH ON)

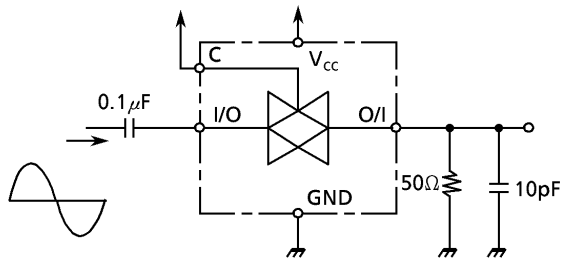

DIP 14PIN OUTLINE DRAWING (DIP14-P-300-2.54)

Unit in mm

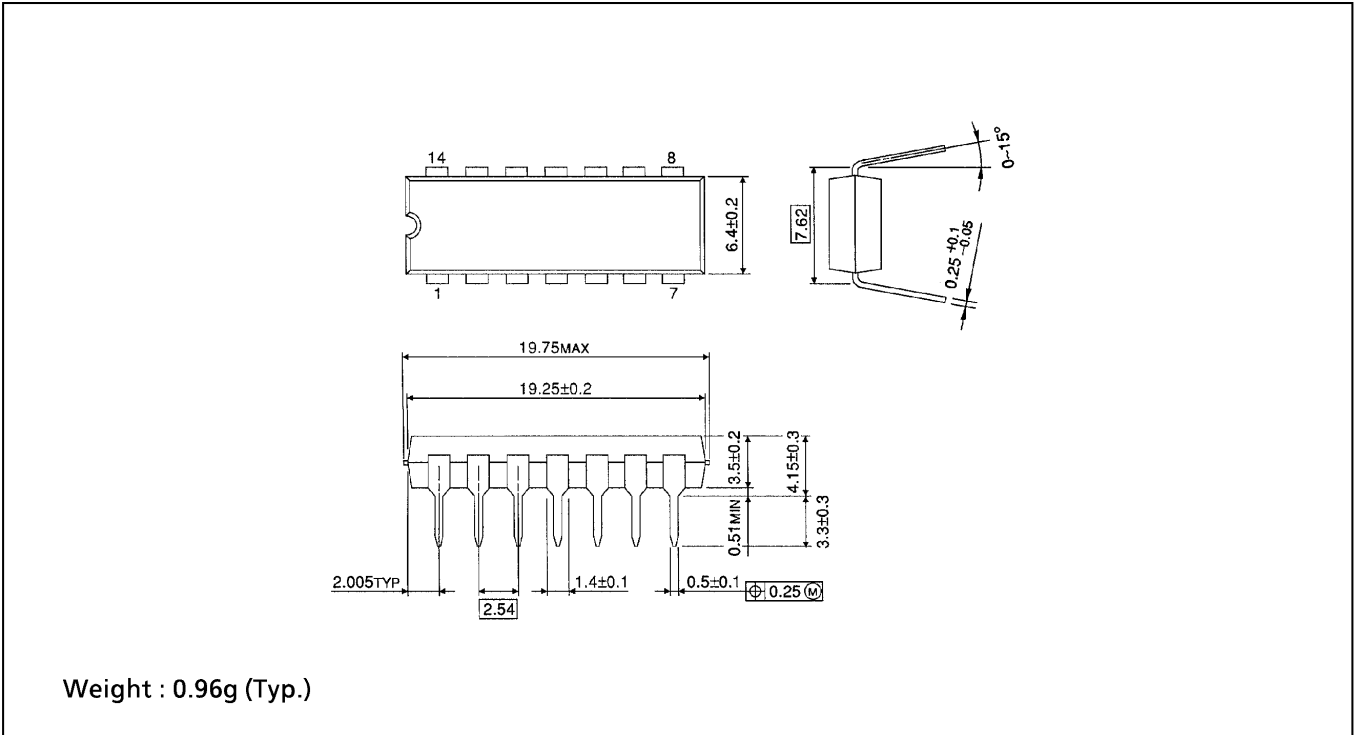

SOP 14PIN (200mil BODY) OUTLINE DRAWING (SOP14-P-300-1.27)

Unit in mm

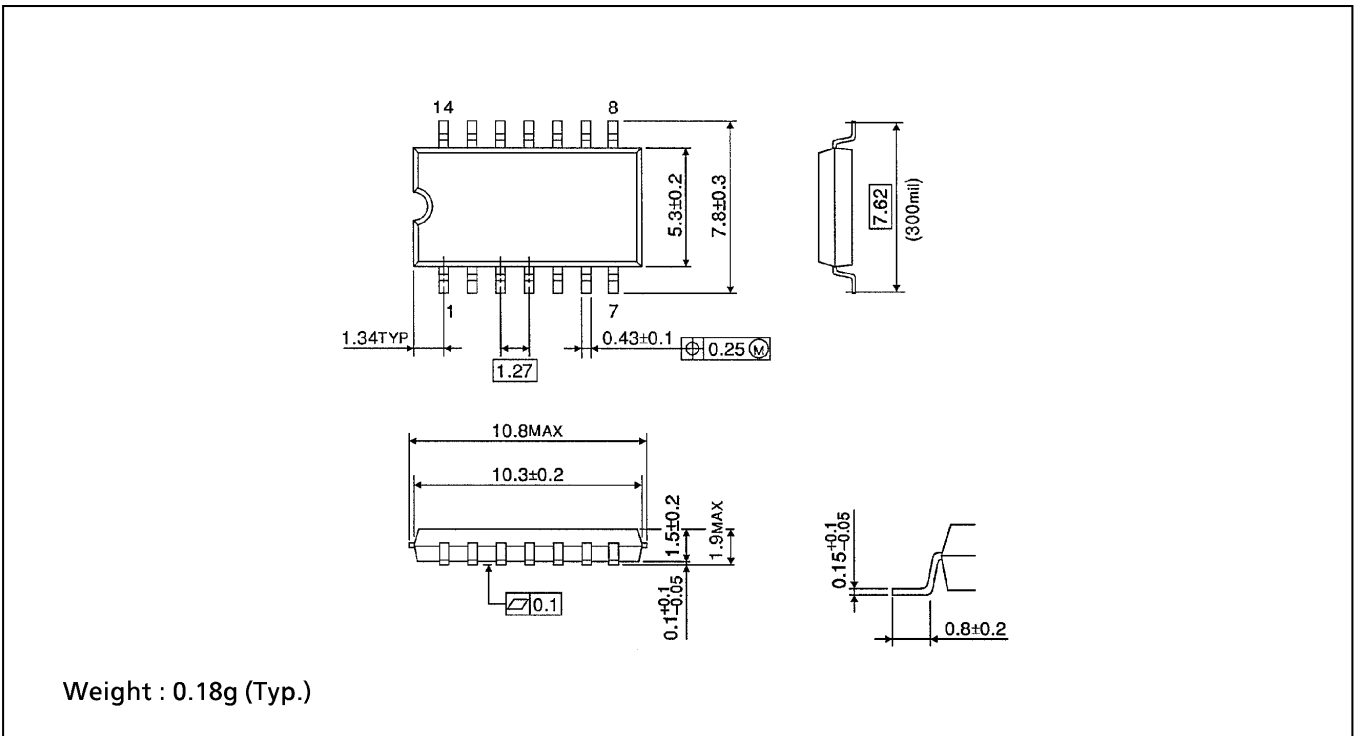

SOP 14PIN (150mil BODY) OUTLINE DRAWING (SOL14-P-150 -1.27)

Unit in mm

(Note) This package is not available in Japan.

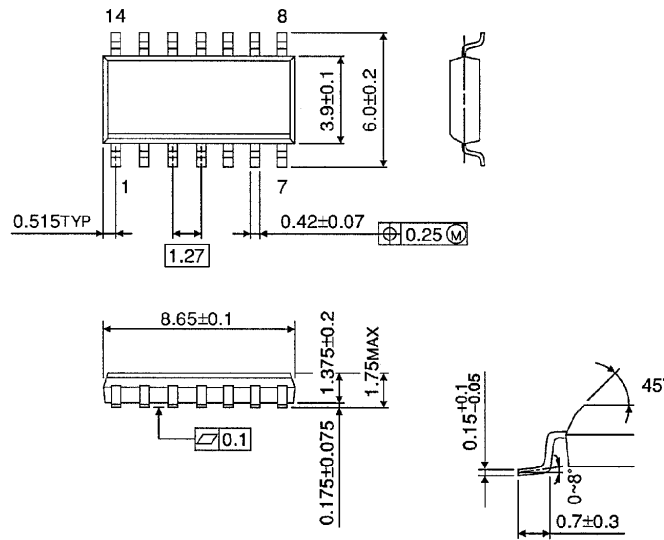

Weight : 0.12g (Typ.)

TSSOP 14PIN (170mil BODY) OUTLINE DRAWING (TSSOP14-P-0044-0.65)

Unit in mm

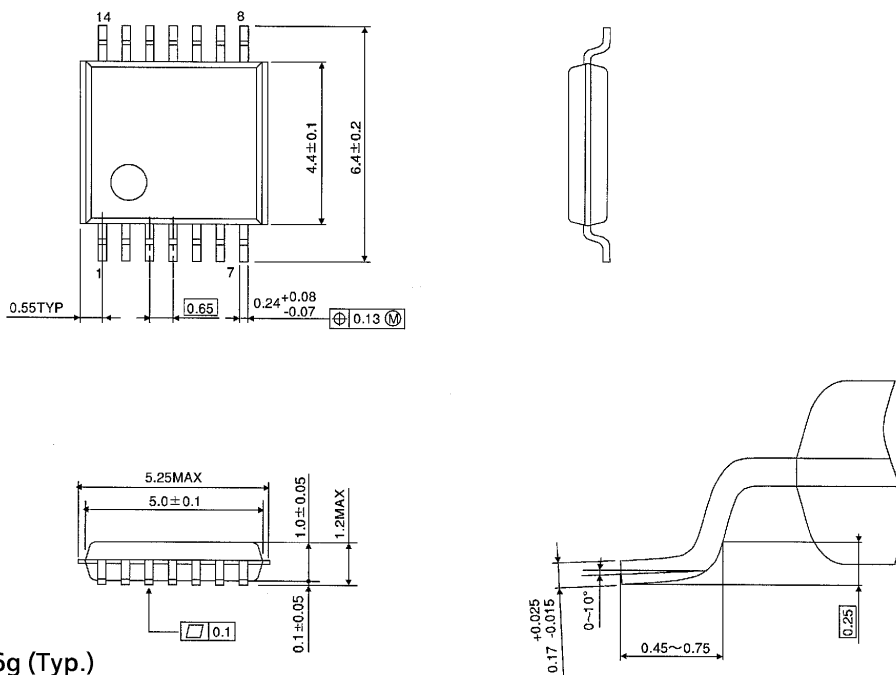

Weight : 0.06g (Typ.)