



16-Channel/Dual 8-Channel, Low-Leakage, CMOS Analog Multiplexers

General Description

The MAX336/MAX337 are monolithic, CMOS analog multiplexers (muxes). The 16-channel MAX336 is designed to connect one of 16 inputs to a common output by control of a 4-bit binary address. The dual, 8-channel MAX337 is designed to connect one of eight inputs to a common output by control of a 3-bit binary address. Both devices can be used as either a mux or a demux. On-resistance is 400Ω (max), and the devices conduct current equally well in both directions.

These muxes feature extremely low off leakages (less than 20pA at +25°C) and on-channel leakages (less than 50pA at +25°C). The new design offers guaranteed low charge injection (3.5pC typical) and electrostatic discharge (ESD) protection greater than 2000V, per method 3015.7. These improved muxes are pin-compatible upgrades for the industry-standard DG506 and DG507.

The MAX336/MAX337 operate from a single +4.5V to +30V supply or from dual ±4.5V to ±20V supplies. All control inputs (whether address or enable) are TTL compatible (0.8V to 2.4V) over the full specified temperature range and over the ±4.5V to ±18V supply range.

Applications

- Precision Data Acquisition
- Precision Signal Routing
- Test Equipment

Features

- ◆ <400Ω (max) On-Resistance
- ◆ <500ns Transition Time
- ◆ <10Ω On-Resistance Match
- ◆ <20pA NO-Off Leakage Current at +25°C
- ◆ 3.5pC Charge Injection
- ◆ +4.5V to +30V Single Supply
±4.5V to ±20V Dual Supplies
- ◆ Plug-In Upgrade for Industry-Standard DG506/DG507
- ◆ Bidirectional Rail-to-Rail® Signal Handling
- ◆ TTL/CMOS-Logic Compatible
- ◆ >2000V ESD Protection, per Method 3015.7

Ordering Information

PART	TEMP. RANGE	PIN-PACKAGE
MAX336CPI	0°C to +70°C	28 Plastic DIP
MAX336CWI	0°C to +70°C	28 Wide SO
MAX336CAI	0°C to +70°C	28 SSOP
MAX336C/D	0°C to +70°C	Dice*

Ordering Information continued at end of data sheet.
* Contact factory for dice specifications.

Pin Configurations/Functional Diagrams/Truth Tables

TOP VIEW

DIP/SO/SSOP
N.C. = NO INTERNAL CONNECTION

MAX336 16-CHANNEL SINGLE-ENDED MULTIPLEXER

MAX336					
A3	A2	A1	A0	EN	ON SWITCH
X	X	X	X	0	NONE
0	0	0	0	1	1
0	0	0	1	1	2
0	0	1	0	1	3
0	0	1	1	1	4
0	1	0	0	1	5
0	1	0	1	1	6
0	1	1	0	1	7
0	1	1	1	1	8
1	0	0	0	1	9
1	0	0	1	1	10
1	0	1	0	1	11
1	0	1	1	1	12
1	1	0	0	1	13
1	1	0	1	1	14
1	1	1	0	1	15
1	1	1	1	1	16

LOGIC '0' = V_{AL} ≤ 0.8V, LOGIC '1' = V_{AH} ≥ 2.4V
Continued at end of data sheet.

MAX336/MAX337

16-Channel/Dual 8-Channel, Low-Leakage, CMOS Analog Multiplexers

ABSOLUTE MAXIMUM RATINGS

Voltage Referenced to V-	Wide SO (derate 12.50mW/°C above +70°C).....	1.00W
V+	SSOP (derate 9.52mW/°C above +70°C)	762mW
GND	CERDIP (derate 16.67mW/°C above +70°C).....	1.33W
Digital Inputs, A_, EN_, NO, COM	Operating Temperature Ranges	
(Note 1).....(V- - 0.3V) to (V+ + 0.3V)	MAX336C_/MAX337C_.....	0°C to +70°C
or 30mA (whichever occurs first)	MAX336E_/MAX337E_.....	-40°C to +85°C
Continuous Current (any terminal)	MAX336MJI/MAX337MJI	-55°C to +125°C
Peak Current, NO or COM	Storage Temperature Range	-65°C to +150°C
(pulsed at 1ms, 10% duty cycle max)	Lead Temperature (soldering, 10sec)	+300°C
Continuous Power Dissipation (T _A = +70°C)		
Plastic DIP (derate 14.29mW/°C above +70°C)		1.14W

Note 1: Signals on any terminal exceeding V+ or V- are clamped by internal diodes. Limit forward current to maximum current rating.

Stresses beyond those listed under "Absolute Maximum Ratings" may cause permanent damage to the device. These are stress ratings only, and functional operation of the device at these or any other conditions beyond those indicated in the operational sections of the specifications is not implied. Exposure to absolute maximum rating conditions for extended periods may affect device reliability.

ELECTRICAL CHARACTERISTICS—Dual Supplies

(V+ = +15V, V- = -15V, GND = 0V, V_{AH} = +2.4V, V_{AL} = +0.8V, T_A = T_{MIN} to T_{MAX}, unless otherwise noted.)

PARAMETER	SYMBOL	CONDITIONS		MIN	TYP (Note 2)	MAX	UNITS		
SWITCH									
Analog Signal Range	V _{NO} , V _{COM}	(Note 3)		-15		15	V		
On-Resistance	R _{ON}	I _{NO} = 0.2mA, V _{COM} = ±10V	T _A = +25°C		220	400	Ω		
			T _A = T _{MIN} to T _{MAX}			500			
On-Resistance Matching Between Channels	ΔR _{ON}	I _{NO} = 0.2mA, V _{COM} = ±10V (Note 4)	T _A = +25°C		5	10	Ω		
			T _A = T _{MIN} to T _{MAX}			15			
NO-Off Leakage Current (Note 5)	I _{NO(OFF)}	V _{COM} = ∓10V, V _{NO} = ±10V, V _{EN} = 0V	T _A = +25°C		-0.02	0.001	0.02	nA	
			T _A = T _{MIN} to T _{MAX}	C, E		-1.25			1.25
				M			-20		
COM-Off Leakage Current (Note 5)	I _{COM(OFF)}	V _{NO} = ±10V, V _{COM} = ∓10V, V _{EN} = 0V	MAX336	T _A = +25°C		-0.05	0.05	nA	
				T _A = T _{MIN} to T _{MAX}	C, E		-6.5		6.5
			M				-80		80
		MAX337	T _A = +25°C		-0.05	0.05			
			T _A = T _{MIN} to T _{MAX}	C, E		-3.25	3.25		
				M			-40		40
COM-On Leakage Current (Note 5)	I _{COM(ON)}	V _{COM} = ±10V, V _{NO} = ±10V, sequence each switch on	MAX336	T _A = +25°C		-0.05	0.05	nA	
				T _A = T _{MIN} to T _{MAX}	C, E		-6.5		6.5
			M				-80		80
		MAX337	T _A = +25°C		-0.05	0.05			
			T _A = T _{MIN} to T _{MAX}	C, E		-3.25	3.25		
				M			-40		40

16-Channel/Dual 8-Channel, Low-Leakage, CMOS Analog Multiplexers

MAX3336/MAX3337

ELECTRICAL CHARACTERISTICS—Dual Supplies (continued)

(V+ = +15V, V- = -15V, GND = 0V, V_{AH} = +2.4V, V_{AL} = +0.8V, T_A = T_{MIN} to T_{MAX}, unless otherwise noted.)

PARAMETER	SYMBOL	CONDITIONS	MIN	TYP (Note 2)	MAX	UNITS	
INPUT							
Input Current with Input Voltage High	I _{AH}	V _A = 2.4V or 15V	-1.0	0.001	1.0	μA	
Input Current with Input Voltage Low	I _{AL}	V _{EN} = 0V or 2.4V, V _A = 0V	-1.0		1.0	μA	
SUPPLY							
Power-Supply Range			±4.5		±20	V	
Positive Supply Current	I+	V _{EN} = V _A = 0V	T _A = +25°C	-1	0.01	1	μA
			T _A = T _{MIN} to T _{MAX}	-10		10	
		V _{EN} = 2.4V, V _{A(ALL)} = 2.4V	T _A = +25°C		400	700	
			T _A = T _{MIN} to T _{MAX}			1100	
Negative Supply Current	I-	V _{EN} = 0V or 2.4V; V _{A(ALL)} = 0V, 2.4V, or 5V	T _A = +25°C	-1		1	μA
			T _A = T _{MIN} to T _{MAX}	-10		10	
DYNAMIC							
Transition Time	t _{TRANS}	Figure 2, T _A = +25°C		200	500	ns	
Break-Before-Make Interval	t _{OPEN}	Figure 4, T _A = +25°C	10	50		ns	
Enable Turn-On Time	t _{ON(EN)}	Figure 3	T _A = +25°C		250	500	ns
			T _A = T _{MIN} to T _{MAX}			750	
Enable Turn-Off Time	t _{OFF(EN)}	Figure 3	T _A = +25°C		100	500	ns
			T _A = T _{MIN} to T _{MAX}			750	
Charge Injection (Note 3)	Q	C _L = 100pF, V _{NO} = 0V, R _S = 0Ω, Figure 6, T _A = +25°C		3.5	10	pC	
Off Isolation (Note 6)	V _{ISO}	V _{EN} = 0V, R _L = 1kΩ, f = 100kHz, T _A = +25°C		-82		dB	
Crosstalk Between Channels	V _{CT}	V _{EN} = 2.4V, f = 100kHz, V _{GEN} = 1Vp-p, R _L = 1kΩ, Figure 7, T _A = +25°C		-86		dB	
Logic Input Capacitance	C _{IN}	f = 1MHz, T _A = +25°C		2		pF	
NO-Off Capacitance	C _{NO(OFF)}	f = 1MHz, V _{EN} = V _{NO} = 0V, Figure 8, T _A = +25°C		2		pF	
COM-Off Capacitance	C _{COM(OFF)}	f = 1MHz, V _{EN} = 0.8V, V _{COM} = 0V, Figure 8, T _A = +25°C	MAX336		20	pF	
			MAX337		10		
COM-On Capacitance	C _{COM(ON)}	f = 1MHz, V _{EN} = 2.4V, V _{COM} = 0V, Figure 8, T _A = +25°C	MAX336		22	pF	
			MAX337		12		

16-Channel/Dual 8-Channel, Low-Leakage, CMOS Analog Multiplexers

ELECTRICAL CHARACTERISTICS—Single Supply

(V+ = +12V, V- = 0V, GND = 0V, V_{AH} = +2.4V, V_{AL} = +0.8V, T_A = T_{MIN} to T_{MAX}, unless otherwise noted.)

PARAMETER	SYMBOL	CONDITIONS	MIN	TYP (Note 2)	MAX	UNITS
SWITCH						
Analog Signal Range	V _{NO} , V _{COM}	(Note 3)	0		12	V
On-Resistance	R _{ON}	I _{NO} = 0.2mA, V _{COM} = 3V or 10V, T _A = +25°C		460	700	Ω
DYNAMIC						
Transition Time (Note 3)	t _{TRANS}	V _{NO-} = ±5V, V _{IN} = 2.4V, Figure 1, T _A = +25°C		350	600	ns
Enable Turn-On Time (Note 3)	t _{ON(EN)}	V _{INH} = 2.4V, V _{INL} = 0V, V _{NO1} = 5V, Figure 3, T _A = +25°C		350	600	ns
Enable Turn-Off Time (Note 3)	t _{OFF(EN)}	V _{INH} = 2.4V, V _{INL} = 0V, V _{NO1} = 5V, Figure 3, T _A = +25°C		110	500	ns
Charge Injection (Note 3)	Q	C _L = 100pF, V _{NO} = 0V, R _S = 0Ω, T _A = +25°C		5.0	10	pC

Note 2: The algebraic convention where the most negative value is a minimum and the most positive value a maximum is used in this data sheet.

Note 3: Guaranteed by design.

Note 4: ΔR_{ON} = R_{ON(MAX)} - R_{ON(MIN)}.

Note 5: Leakage parameters are 100% tested at the maximum rated hot temperature and guaranteed by correlation at T_A = +25°C.

Note 6: Worst-case isolation is on channel 4 because of its proximity to the drain pin. Off isolation = 20log V_{COM}/V_{NO}, where V_{COM} = output and V_{NO} = input to off switch.

Typical Operating Characteristics

(T_A = +25°C, unless otherwise noted.)

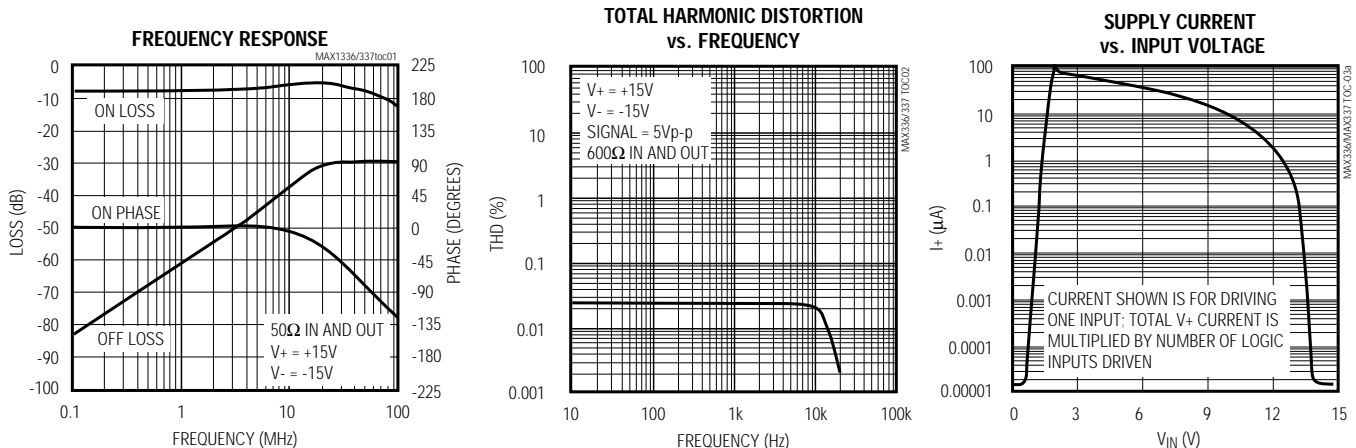

16-Channel/Dual 8-Channel, Low-Leakage, CMOS Analog Multiplexers

Typical Operating Characteristics (continued)

($T_A = +25^\circ\text{C}$, unless otherwise noted.)

MAX336/MAX337

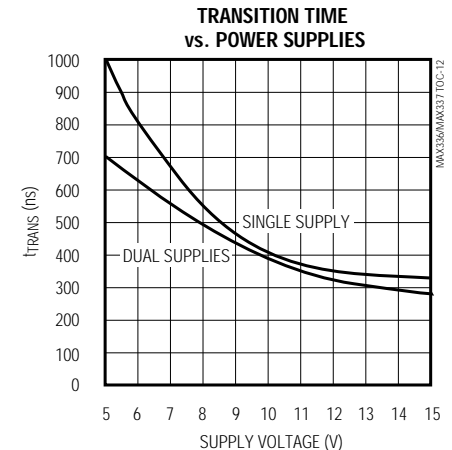
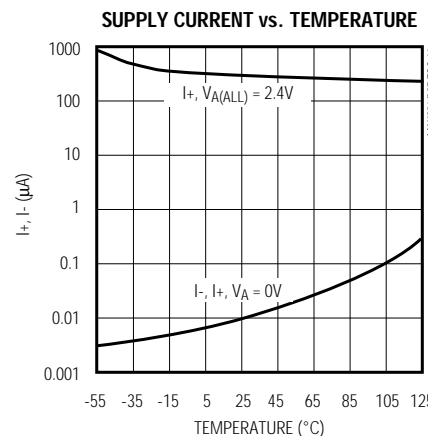
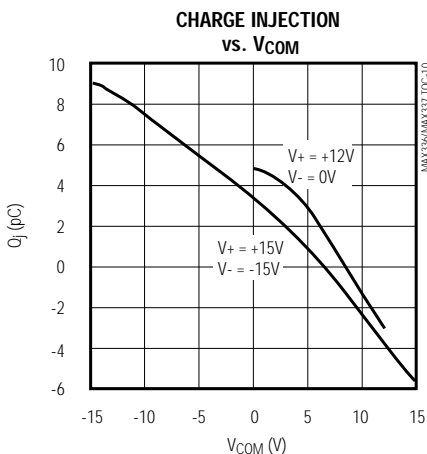
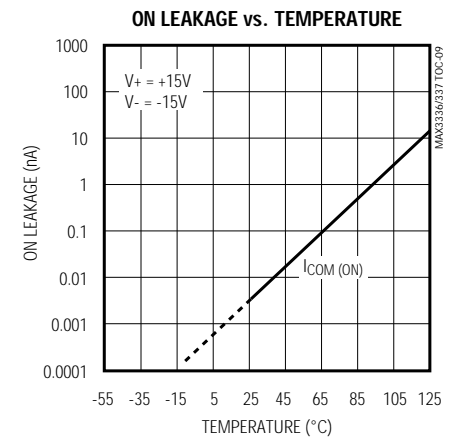
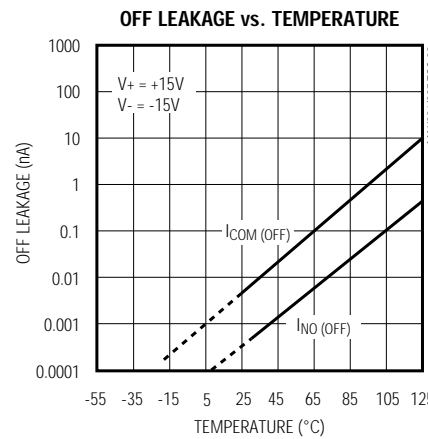
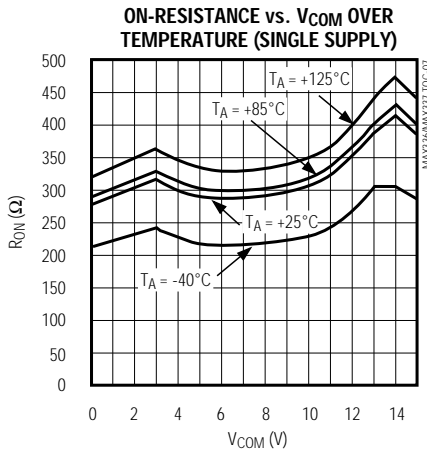
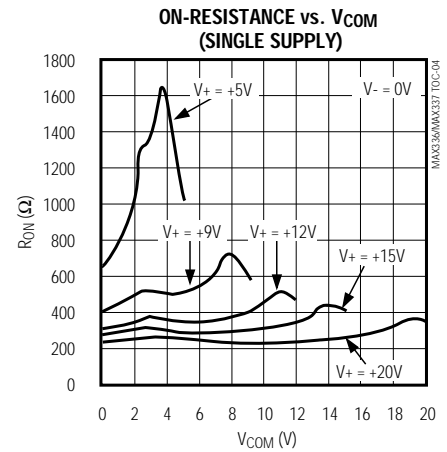
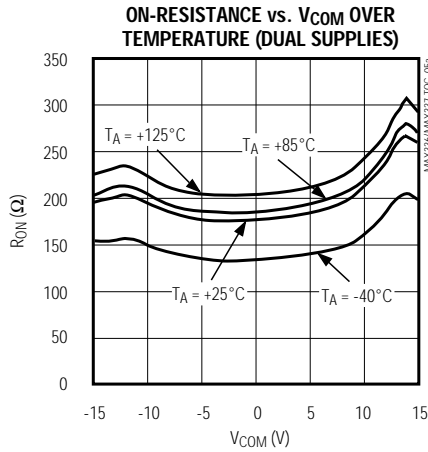
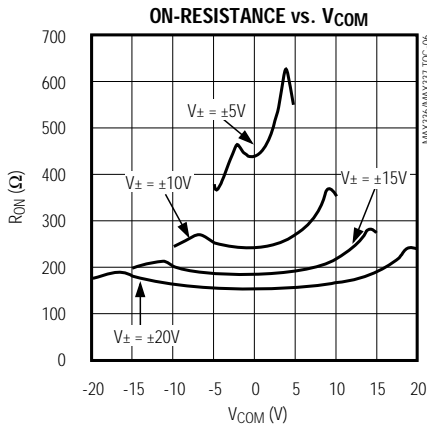

16-Channel/Dual 8-Channel, Low-Leakage, CMOS Analog Multiplexers

Pin Description

PIN		NAME	FUNCTION
MAX336	MAX337		
1	1	V+	Positive Supply-Voltage Input
2, 3, 13	3, 13, 14	N.C.	No Internal Connection
—	2	COMB	Analog Signal B Output* (bidirectional)
4–11	—	NO16–NO9	Analog Signal Inputs* (bidirectional)
—	4–11	NO8B–NO1B	Analog Signal B Inputs* (bidirectional)
12	12	GND	Logic Ground
14–17	—	A3–A0	Logic Address Inputs
—	15, 16, 17	A2, A1, A0	Logic Address Inputs
18	18	EN	Logic Enable Input
19–26	—	NO1–NO8	Analog Signal Inputs* (bidirectional)
—	19–26	NO1A–NO8A	Analog Signal A Inputs* (bidirectional)
27	27	V-	Negative Supply-Voltage Input. Connect to GND for single-supply operation.
28	—	COM	Analog Signal Output* (bidirectional)
—	28	COMA	Analog Signal A Output* (bidirectional)

* Analog signal inputs and outputs are names of convenience only; they are identical and interchangeable.

Applications Information

Operation with Supply Voltages Other than 15V

Using supply voltages less than $\pm 15\text{V}$ will reduce the analog signal range. The MAX336/MAX337 switches operate with $\pm 4.5\text{V}$ to $\pm 20\text{V}$ bipolar supplies or with a $+4.5\text{V}$ to $+30\text{V}$ single supply. Connect V- to GND when operating with a single supply. Both device types can also operate with unbalanced supplies such as $+24\text{V}$ and -5V . The *Typical Operating Characteristics* graphs show typical on-resistance with 20V, 15V, 10V, and 5V supplies. (Switching times increase by a factor of two or more for operation at 5V.)

Overvoltage Protection

Proper power-supply sequencing is recommended for all CMOS devices. Do not exceed the absolute maximum ratings, because stresses beyond the listed ratings may cause permanent damage to the devices. Always sequence V+ on first, then V-, followed by the logic inputs NO and COM. If power-supply sequencing is not possible, add two small signal diodes in series with supply pins for overvoltage protection (Figure 1). Adding diodes reduces the analog signal range to 1V below V+ and 1V above V-, but does not significantly affect the devices' low switch resistance and low leakage characteristics. Device operation is unchanged, and the difference between V+ and V- should not exceed 44V.

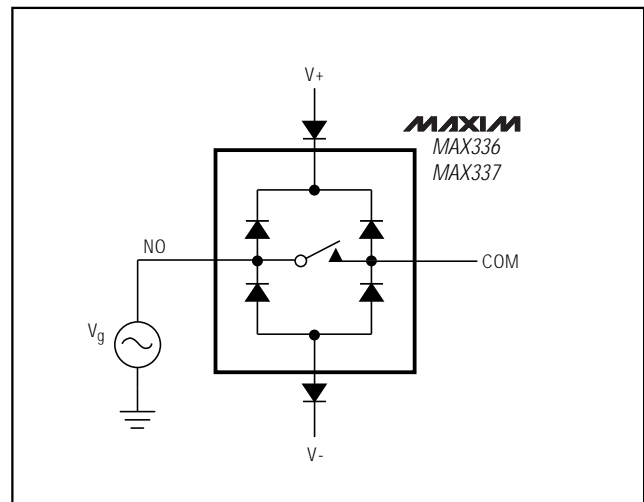

Figure 1. Overvoltage Protection Using External Blocking Diodes

16-Channel/Dual 8-Channel, Low-Leakage, CMOS Analog Multiplexers

Test Circuits/Timing Diagrams

MAX3336/MAX3337

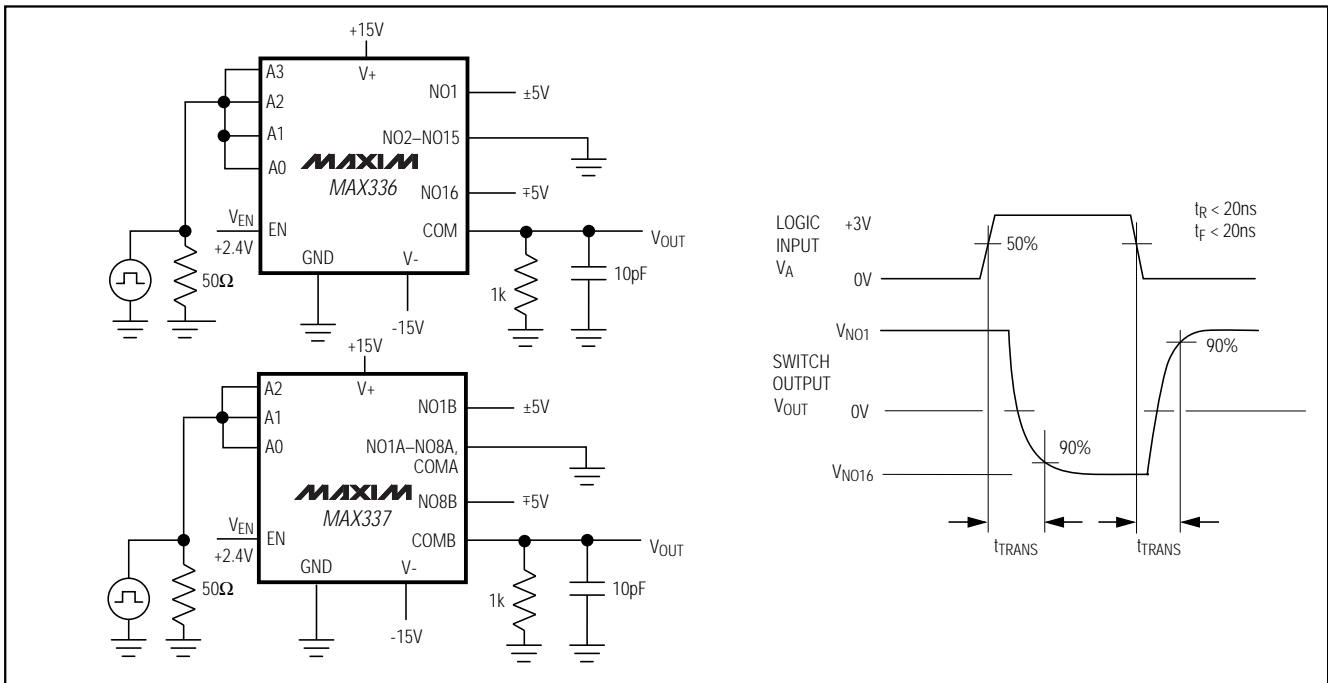

Figure 2. Transition Time

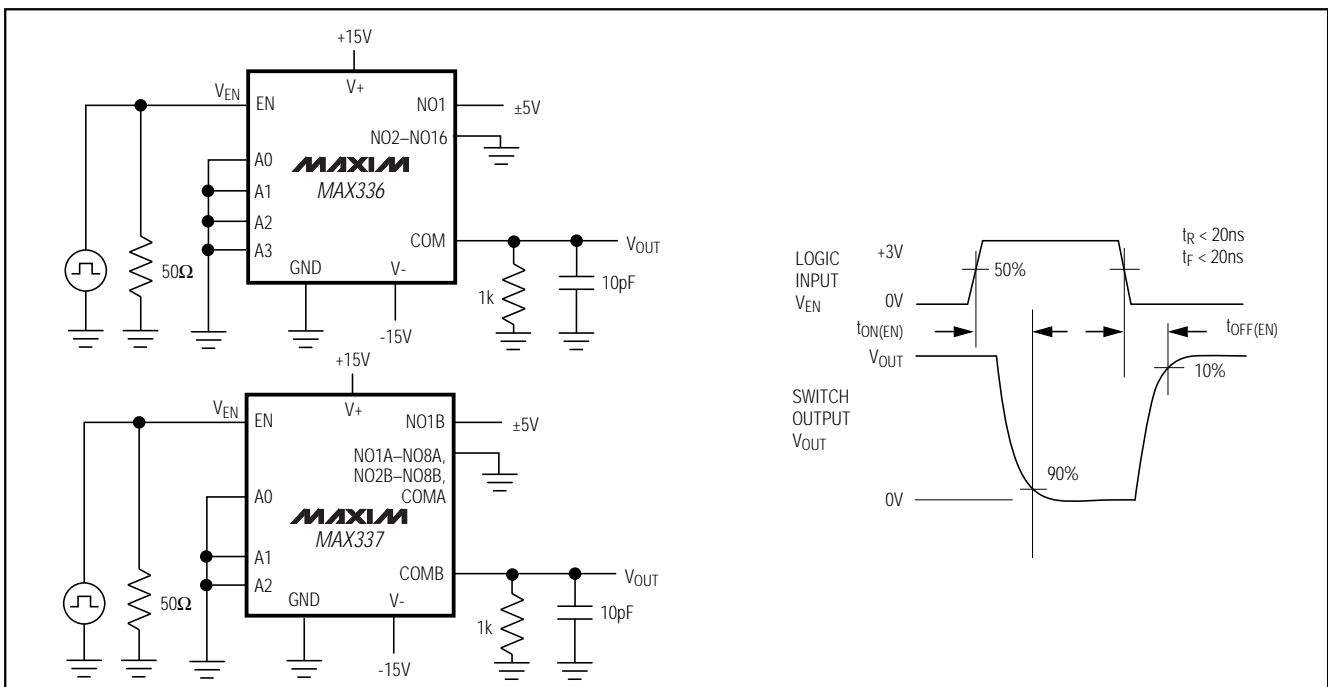

Figure 3. Enable Switching Time

16-Channel/Dual 8-Channel, Low-Leakage, CMOS Analog Multiplexers

Test Circuits/Timing Diagrams (continued)

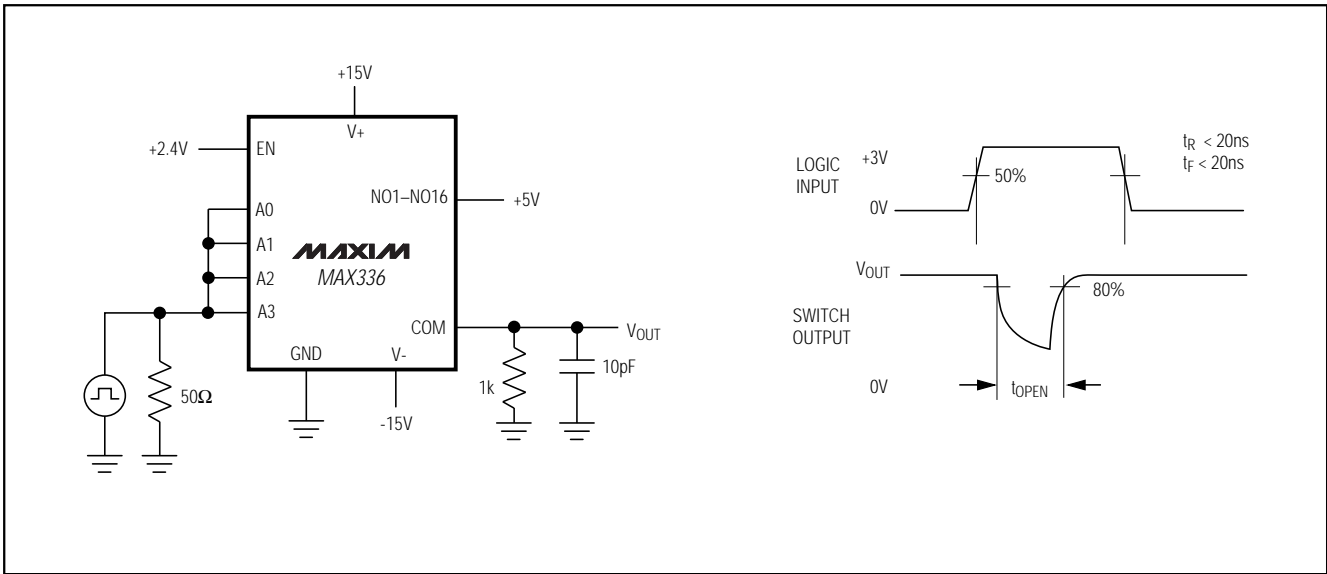

Figure 4. Break-Before-Make Interval

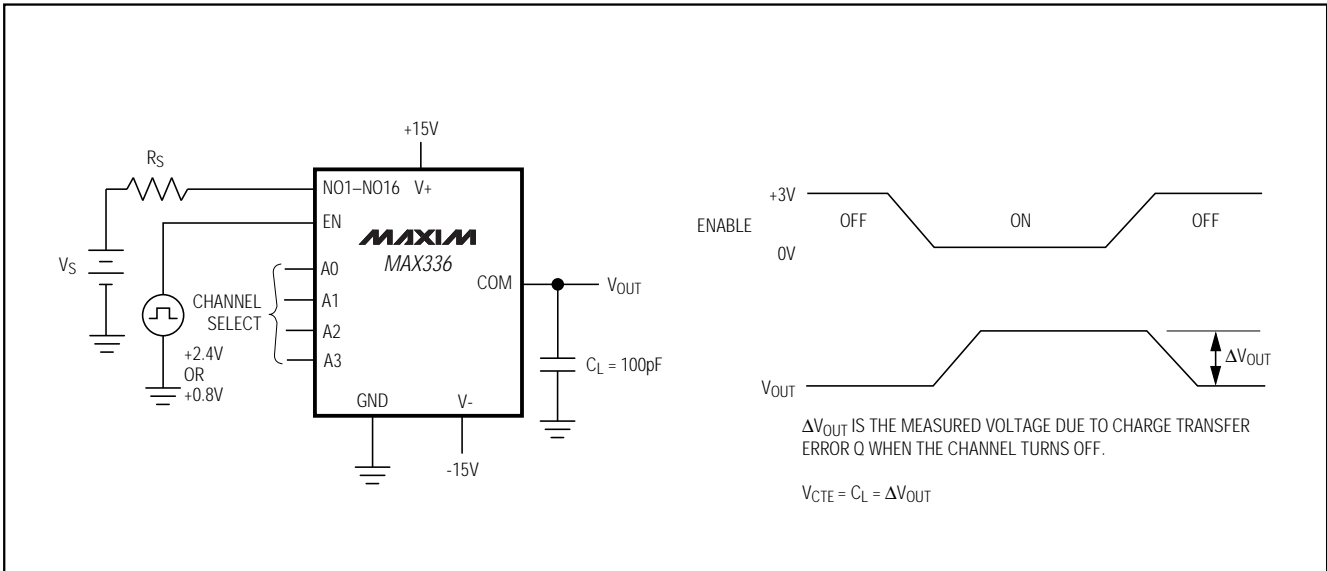

Figure 5. Charge Injection (V_{CTE})

16-Channel/Dual 8-Channel, Low-Leakage, CMOS Analog Multiplexers

Test Circuits/Timing Diagrams (continued)

MAX3336/MAX3337

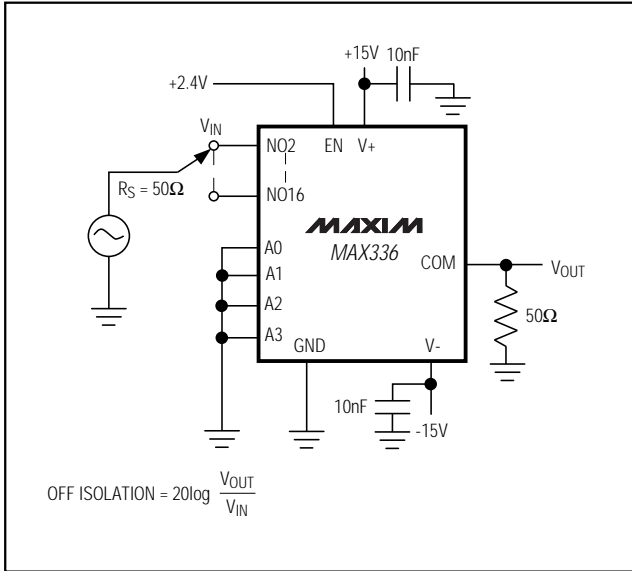

Figure 6. Off Isolation

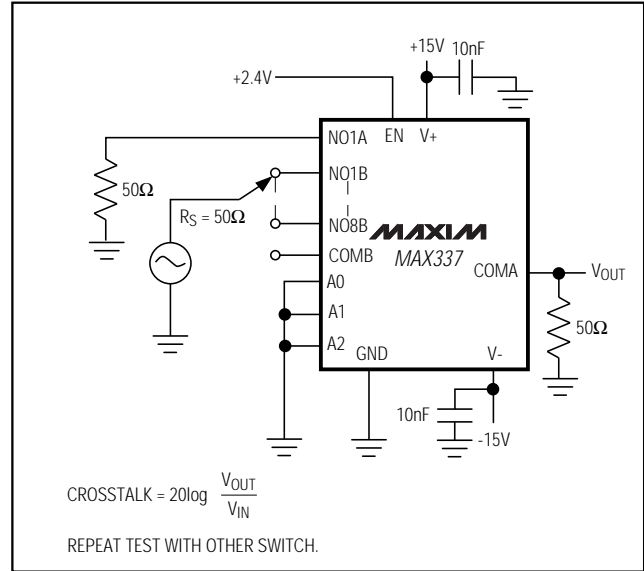

Figure 7. Crosstalk

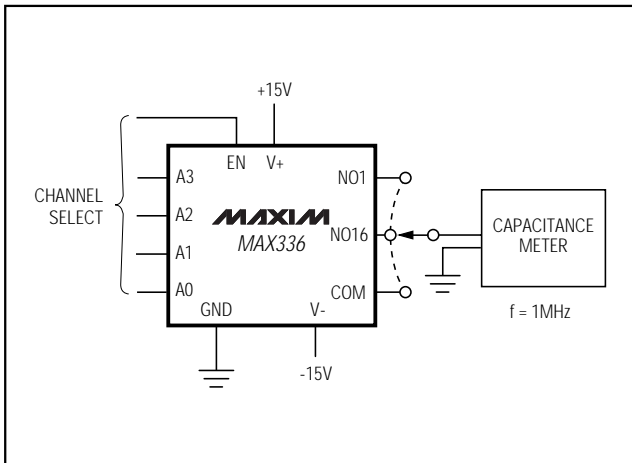
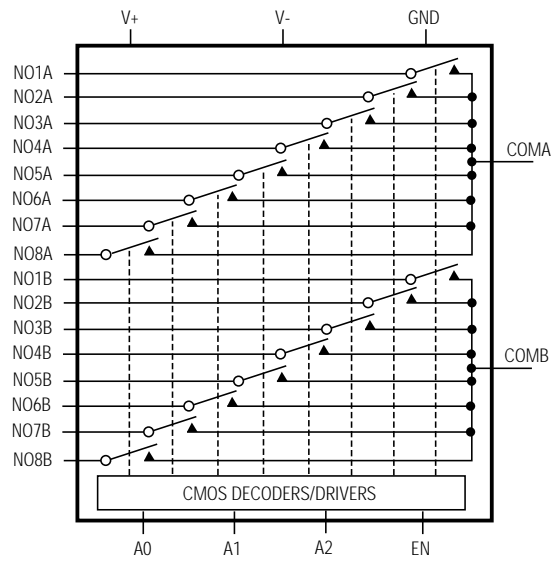
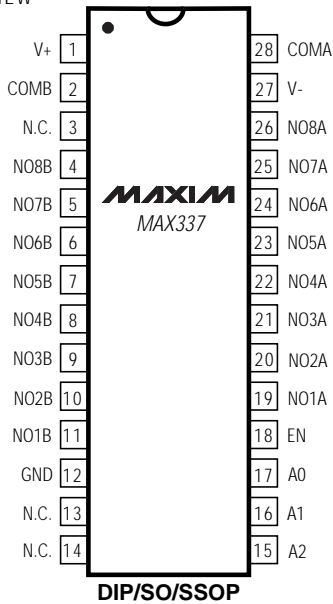

Figure 8. NO/COM Capacitance

16-Channel/Dual 8-Channel, Low-Leakage, CMOS Analog Multiplexers

_____ Pin Configurations/Functional Diagrams/Truth Tables (continued)

TOP VIEW



MAX337 8-CHANNEL DIFFERENTIAL MULTIPLEXER

MAX337				
A2	A1	A0	EN	ON SWITCH
X	X	X	0	NONE
0	0	0	1	1
0	0	1	1	2
0	1	0	1	3
0	1	1	1	4
1	0	0	1	5
1	0	1	1	6
1	1	0	1	7
1	1	1	1	8

LOGIC "0" = $V_{AL} \leq 0.8V$, LOGIC "1" = $V_{AH} \geq 2.4V$

16-Channel/Dual 8-Channel, Low-Leakage, CMOS Analog Multiplexers

Ordering Information (continued)

PART	TEMP. RANGE	PIN-PACKAGE
MAX336EPI	-40°C to +85°C	28 Plastic DIP
MAX336EWI	-40°C to +85°C	28 Wide SO
MAX336EAI	-40°C to +85°C	28 SSOP
MAX336EJI	-40°C to +85°C	28 CERDIP**
MAX336MJI	-55°C to +125°C	28 CERDIP**
MAX337CPI	0°C to +70°C	28 Plastic DIP
MAX337CWI	0°C to +70°C	28 Wide SO
MAX337CAI	0°C to +70°C	28 SSOP
MAX337C/D	0°C to +70°C	Dice*
MAX337EPI	-40°C to +85°C	28 Plastic DIP
MAX337EWI	-40°C to +85°C	28 Wide SO
MAX337EAI	-40°C to +85°C	28 SSOP
MAX337EJI	-40°C to +85°C	28 CERDIP**
MAX337MJI	-55°C to +125°C	28 CERDIP**

* Contact factory for dice specifications.

** Contact factory for availability.

Chip Topography

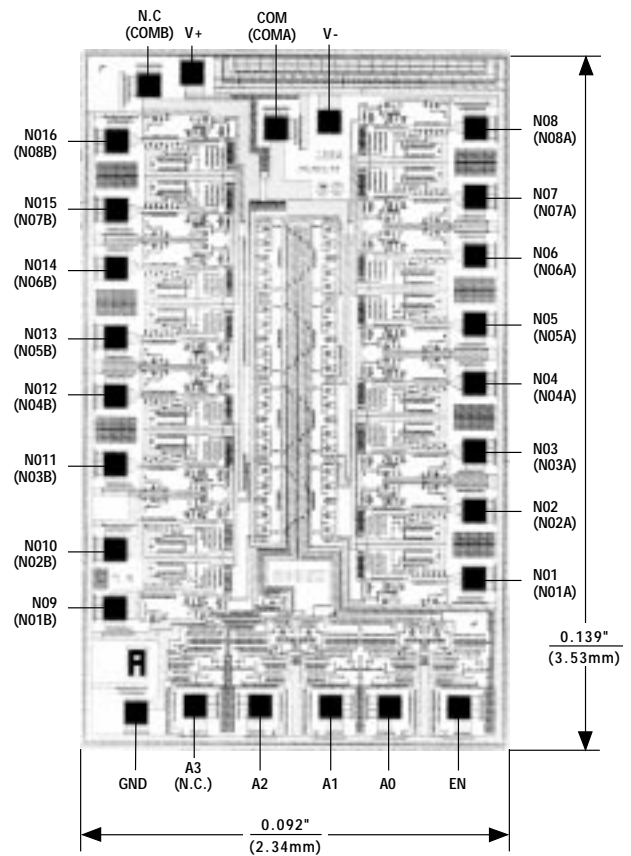

MAX336/MAX337

() ARE FOR MAX337

TRANSISTOR COUNT: 466

BACKSIDE IS V+

SUBSTRATE CONNECTED TO V+

16-Channel/Dual 8-Channel, Low-Leakage, CMOS Analog Multiplexers

Package Information

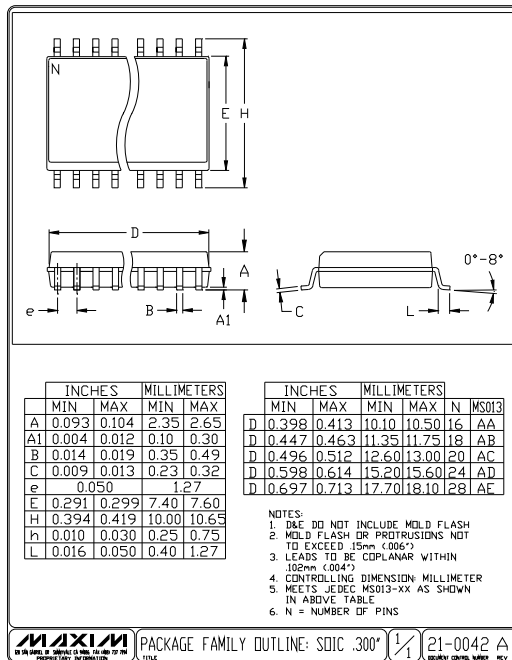
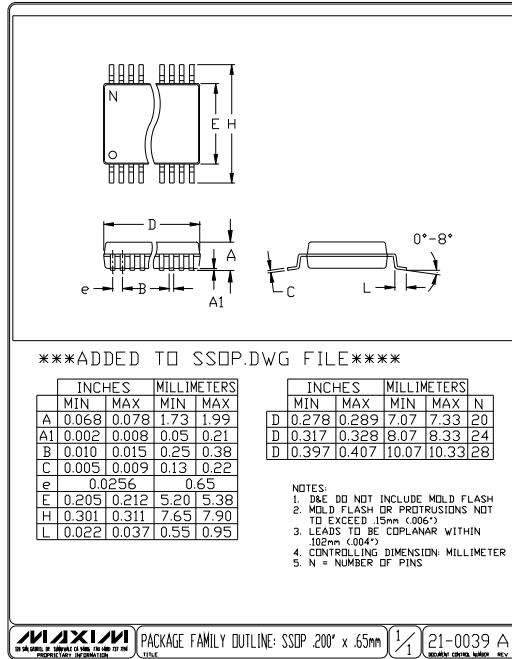

Maxim cannot assume responsibility for use of any circuitry other than circuitry entirely embodied in a Maxim product. No circuit patent licenses are implied. Maxim reserves the right to change the circuitry and specifications without notice at any time.