



LTC1257

Complete Single Supply 12-Bit Voltage Output DAC in SO-8

FEATURES

- 8-Pin SO Package
- Buffered Voltage Output
- Built-In 2.048V Reference
- 500 μ V/LSB with 2.048V Full Scale
- 1/2LSB Max DNL Error
- Guaranteed 12-Bit Monotonic
- 3-Wire Cascadable Serial Interface
- Wide Single Supply Range: V_{CC} = 4.75V to 15.75V
- Low Power: I_{CC} Typ = 350 μ A with 5V Supply

APPLICATIONS

- Digital Offset/Gain Adjustment
- Industrial Process Control
- Automatic Test Equipment

DESCRIPTION

The LTC[®]1257 is a complete single supply, 12-bit voltage output D/A converter (DAC) in an SO-8 package. The LTC1257 includes an output buffer amplifier, 2.048V voltage reference and an easy to use three-wire cascadable serial interface. An external reference can be used to override the internal reference and extend the output voltage range to 12V. The power supply current is a low 350 μ A when operating from a 5V supply, making the LTC1257 ideal for battery-powered applications. The space-saving 8-pin SO package and operation with no external components provide the smallest 12-bit D/A system available.

Δ , LTC and LT are registered trademarks of Linear Technology Corporation.

TYPICAL APPLICATION

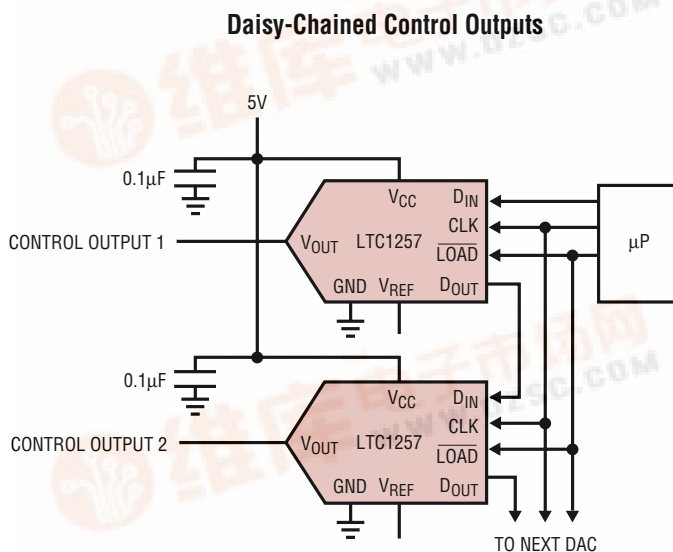

1257 TA01

Differential Nonlinearity vs Input Code

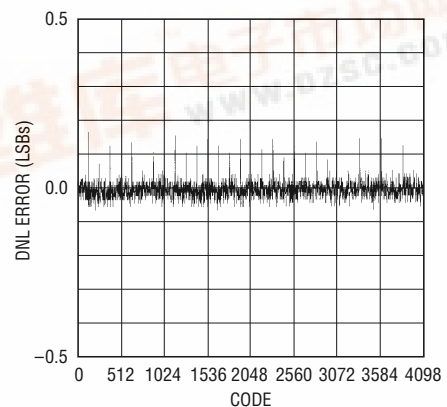

1257 TA05



LTC1257

ABSOLUTE MAXIMUM RATINGS

V_{CC} to GND	-0.5V to 16.5V
TTL Input Voltage	-0.5V to $V_{CC} + 0.5V$
V_{OUT}	-0.5V to $V_{CC} + 0.5V$
REF	-0.5V to $V_{CC} + 0.5V$
Operating Temperature Range	
LTC1257C	0°C to 70°C
LTC1257I	-40°C to 85°C
Maximum Junction Temperature	
Plastic Package	-65°C to 125°C
Storage Temperature Range	-65°C to 150°C
Lead Temperature (Soldering, 10 sec).....	300°C

PACKAGE/ORDER INFORMATION

	ORDER PART NUMBER
	LTC1257CN8 LTC1257IN8
	LTC1257CS8 LTC1257IS8
	S8 PART MARKING
	1257 1257I

Consult factory for Military grade parts.

ELECTRICAL CHARACTERISTICS $V_{CC} = 4.75V$ to $15.75V$, internal or external reference ($2.475V \leq V_{REF} \leq V_{CC} - 2.7V$), $I_{OUT} \leq 2mA$, $T_A = T_{MIN}$ to T_{MAX} , unless otherwise noted.

SYMBOL	PARAMETER	CONDITIONS	MIN	TYP	MAX	UNITS	
DAC							
	Resolution		●	12		Bits	
DNL	Differential Nonlinearity	Guaranteed Monotonic	●		±0.5	LSB	
INL	Integral Nonlinearity	LTC1257C	●		±3.5	LSB	
		LTC1257I	●		±4.0	LSB	
OFF	Offset Error	When Using Internal Reference, LTC1257C	●		±8	LSB	
		When Using Internal Reference, LTC1257I	●		±10	LSB	
		When Using External Reference, LTC1257C	●		±4	mV	
		When Using External Reference, LTC1257I	●		±5	mV	
OFF _{TC}	Offset Error Tempco	When Using Internal Reference (Note 1)	●	±0.02	±0.066	LSB/°C	
		When Using External Reference (Note 1)	●	±15	±30	μV/°C	
FSE	Full-Scale Error		●	0.5	±2	LSB	
FSE _{TC}	Full-Scale Error Tempco	(Note 1)	●	±0.01	±0.02	LSB/°C	
Reference							
	Reference Output Voltage	$I_{OUT} = 0$, LTC1257C	●	2.028	2.048	2.068	V
		$I_{OUT} = 0$, LTC1257I	●	2.018		2.078	V
	Reference Output Tempco	$I_{OUT} = 0$	●	±0.06		LSB/°C	
	Reference Line Regulation	$I_{OUT} = 0$, LTC1257C	●		±0.4	LSB/V	
		$I_{OUT} = 0$, LTC1257I	●		±0.7	LSB/V	
	Reference Load Regulation	$0 \leq I_{OUT} \leq 100\mu A$	●		±1	LSB	
	Reference Input Range	$V_{CC} > V_{REF} + 2.7V$	●	2.475		12	V
	Reference Input Resistance		●	8	14	18	kΩ
	Reference Input Capacitance	(Note 1)			15		pF
	Short-Circuit Current	V_{OUT} Shorted to GND	●			90	mA

ELECTRICAL CHARACTERISTICS

$V_{CC} = 4.75V$ to $15.75V$, internal or external reference
 $(2.475V \leq V_{REF} \leq V_{CC} - 2.7V)$, $I_{OUT} \leq 2mA$, $T_A = T_{MIN}$ to T_{MAX} , unless otherwise noted.

SYMBOL	PARAMETER	CONDITIONS		MIN	TYP	MAX	UNITS
Power Supply							
V_{CC}	Positive Supply Voltage	For Specified Performance	●	4.75		15.75	V
I_{CC}	Supply Current	$4.75V \leq V_{CC} \leq 5.25V$	●		350	600	μA
		$4.75V \leq V_{CC} \leq 15.75V$	●		800	1500	μA
Op Amp DC Performance							
	Short-Circuit Current Low	V_{OUT} Shorted to GND	●			60	mA
	Short-Circuit Current High	V_{OUT} Shorted to V_{CC}	●			60	mA
	Output Impedance to GND	Input Code = 0	●		150	400	Ω
AC Performance							
	Voltage Output Slew Rate	$5k\Omega$ in Parallel with 100pF	●	1.0			V/ μs
	Voltage Output Settling Time	To $\pm 1/2LSB$, $5k\Omega$ in Parallel with 100pF	●			6	μs
	Digital Feedthrough	(Notes 1,2)			50		nV/s
Digital I/O							
V_{IH}	Digital Input High Voltage		●	2.4			V
V_{IL}	Digital Input Low Voltage		●			0.8	V
V_{OH}	Digital Output High Voltage	$I_{OUT} = -1mA$, D_{OUT} Only	●	$V_{CC} - 1$			V
V_{OL}	Digital Output Low Voltage	$I_{OUT} = 1mA$, D_{OUT} Only	●	0.4			V
I_{LEAK}	Digital Input Leakage	$V_{IN} = GND$ to V_{CC}	●			± 10	μA
C_{IN}	Digital Input Capacitance	(Note 1)	●			10	pF
Switching (Note 1)							
t1	D_{IN} Valid to CLK Setup		●	100			ns
t2	D_{IN} Valid to CLK Hold		●	25			ns
t3	CLK High Time		●	350			ns
t4	CLK Low Time		●	350			ns
t5	\overline{LOAD} Pulse Width		●	150			ns
t6	LSB CLK to \overline{LOAD}		●	0			ns
t7	\overline{LOAD} High to CLK		●	0			ns
t8	D_{OUT} Output Delay	$C_{LOAD} = 15pF$	●	35		150	ns
f_{CLK}	Maximum Clock Frequency					1.4	MHz

The ● denotes specifications which apply over the full operating temperature range.

Note 1: Guaranteed by design; not subject to test.

Note 2: DAC switched from all 1s to all 0s, and all 0s to all 1s code.

TYPICAL PERFORMANCE CHARACTERISTICS

Minimum Supply Voltage vs Load Current #1

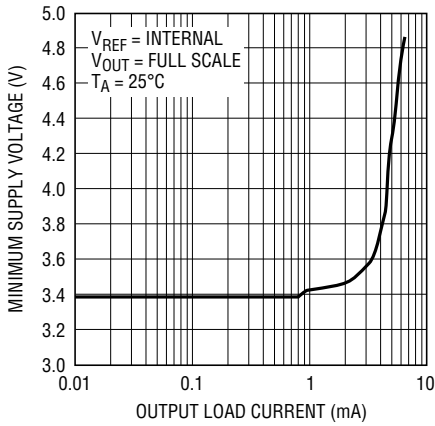

1257 G01

Minimum Supply Voltage vs Load Current #2

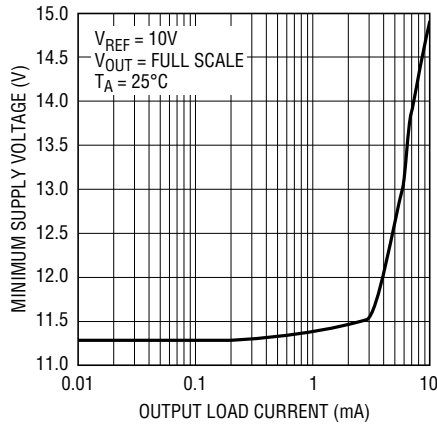

1257 G02

Supply Current vs Temperature

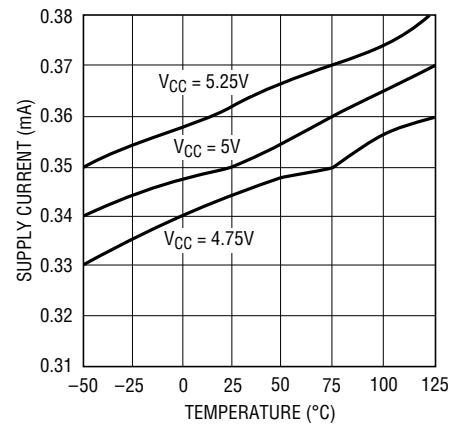

1257 G03

Supply Current vs Logic Input Voltage

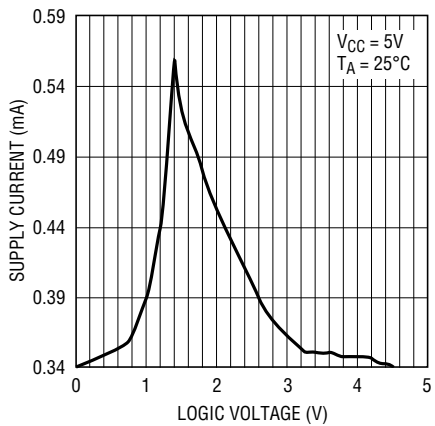

1257 G04

Output Swing vs Load Resistance

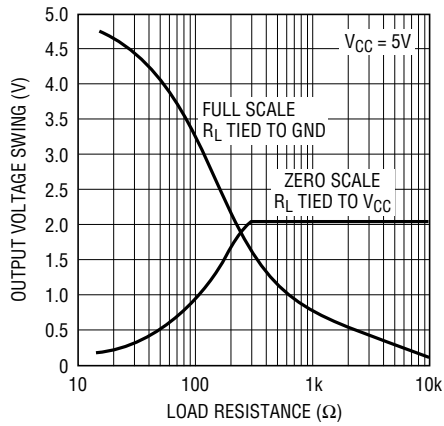

1257 G05

Pull-Down Voltage vs Output Sink Current Capability

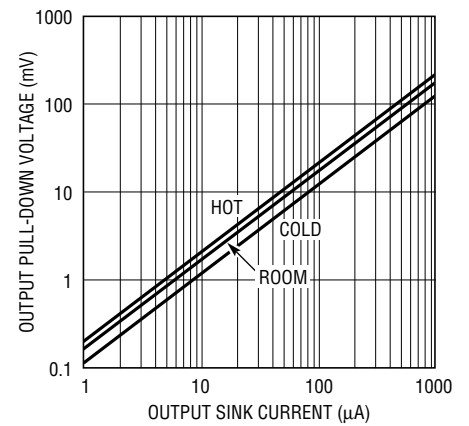

1257 G06

Full-Scale Voltage vs Temperature

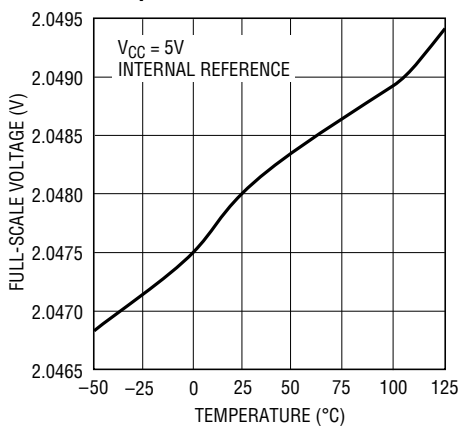

1257 G07

Zero-Scale Voltage vs Temperature

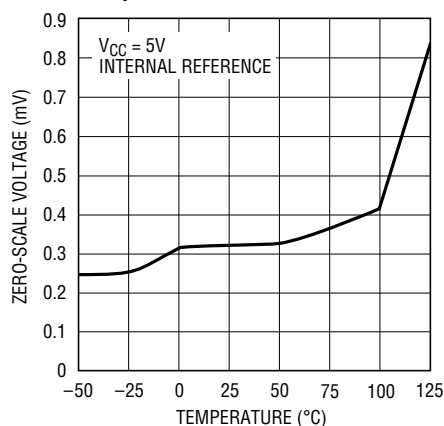

1257 G08

Integral Nonlinearity (INL)

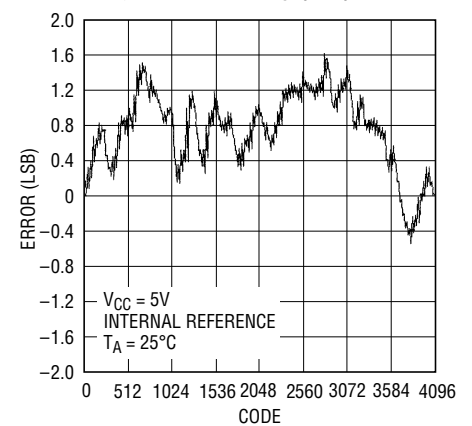

1257 G09

TYPICAL PERFORMANCE CHARACTERISTICS

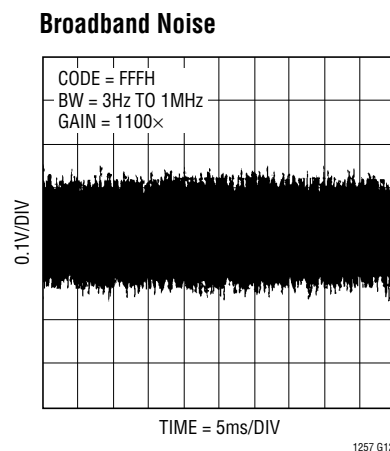
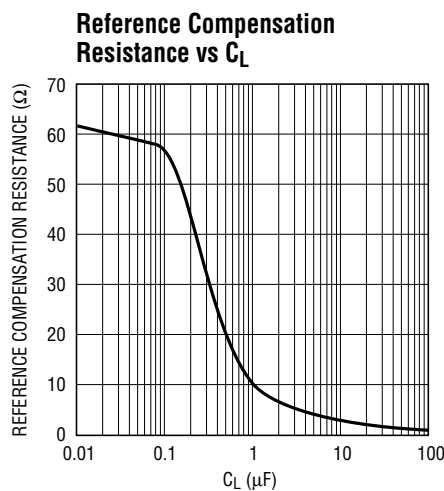
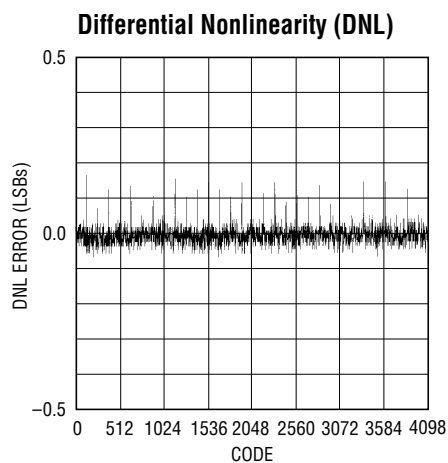

PIN FUNCTIONS

CLK (Pin 1): The TTL level input for the serial interface clock.

D_{IN} (Pin 2): The TTL level input for the serial interface data. Data on the D_{IN} pin is latched into the shift register on the rising edge of the serial clock.

\overline{LOAD} (Pin 3): The TTL level input for the serial interface load control. Data is loaded from the shift register into the DAC register, thus updating the DAC output when \overline{LOAD} is pulled low. The DAC register is transparent as long as \overline{LOAD} is held low.

D_{OUT} (Pin 4): The output of the shift register which becomes valid on the rising edge of the serial clock. The D_{OUT} pin is driven from GND to V_{CC} by an internal CMOS inverter. Multiple LTC1257s may be cascaded by connecting the D_{OUT} pin to the D_{IN} pin of the next chip.

GND (Pin 5): Ground.

REF (Pin 6): The output of the 2.048V reference and the input to the DAC resistor ladder. An external reference with voltage from 2.475V to $V_{CC} - 2.7V$ may be used to override the internal reference.

V_{OUT} (Pin 7): The buffered DAC output is capable of sourcing 2mA over temperature while pulling within 2.7V of V_{CC} . The output will pull to ground through an internal 200 Ω equivalent resistance.

V_{CC} (Pin 8): The positive supply input. $4.75V \leq V_{CC} \leq 15.75V$. Requires a bypass capacitor to ground.

DEFINITIONS

LSB: The least significant bit or the ideal voltage difference between two successive codes.

$$\text{LSB} = (V_{\text{FS}} - V_{\text{OS}})/2^n - 1$$

n = The number of digital input bits

V_{OS} = The zero code error or offset of the DAC

V_{FS} = The full-scale output voltage of the DAC measured when all bits are set to 1

Resolution: The resolution is the number of DAC output states (2^n) that divide the full-scale range. The resolution does not imply linearity.

INL: End-point integral nonlinearity is the maximum deviation from a straight line passing through the end-points of the DAC transfer curve. Because the part operates from a single supply and the output cannot go below ground, the linearity is measured between full-scale and the first code that guarantees a positive output. The INL error at a given input code is calculated as follows:

$$\text{INL} = (V_{\text{OUT}} - V_{\text{IDEAL}})/\text{LSB}$$

$$V_{\text{IDEAL}} = (\text{Code})(\text{LSB}) + V_{\text{OS}}$$

V_{OUT} = The output voltage of the DAC measured at the given input code

DNL: Differential nonlinearity is the difference between the measured change and the ideal 1LSB change between any two adjacent codes. The DNL error between any two codes is calculated as follows:

$$\text{DNL} = (\Delta V_{\text{OUT}} - \text{LSB})/\text{LSB}$$

ΔV_{OUT} = The measured voltage difference between two adjacent codes

Offset Error: The theoretical voltage at the output when the DAC is loaded with all zeros. The output amplifier can have a true negative offset, but because the part is operated from a single supply, the output cannot go below ground. If the offset is negative, the output will remain near 0V resulting in the transfer curve shown in Figure 1.

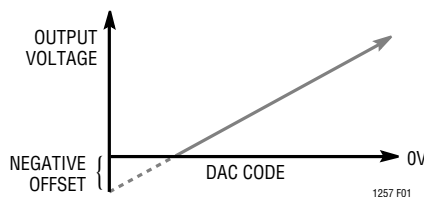

Figure 1. Effect of Negative Offset

The offset of the part is measured at the first code that produces an output voltage 0.5LSB greater than the previous code:

$$V_{\text{OS}} = V_{\text{OUT}} - [(\text{Code})(V_{\text{FS}})/(2^n - 1)]$$

Full-Scale Error: Full-scale error is the difference between the ideal and measured DAC output voltages with all bits set to one (Code = 4095). The full-scale error includes the offset error and is calculated as follows:

$$\text{FSE} = (V_{\text{OUT}} - V_{\text{IDEAL}})/\text{LSB}$$

$$V_{\text{IDEAL}} = (V_{\text{REF}})(1 - 2^{-n}) - V_{\text{OS}}$$

V_{REF} = The reference voltage, either internal or external

Digital Feedthrough: The glitch that appears at the analog output caused by AC coupling from the digital inputs when they change state. The area of the glitch is specified in (nV)(sec).

BLOCK DIAGRAM

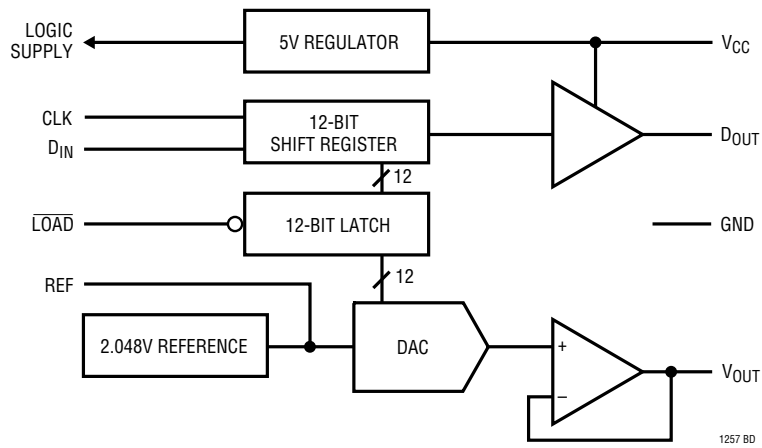

TIMING DIAGRAM

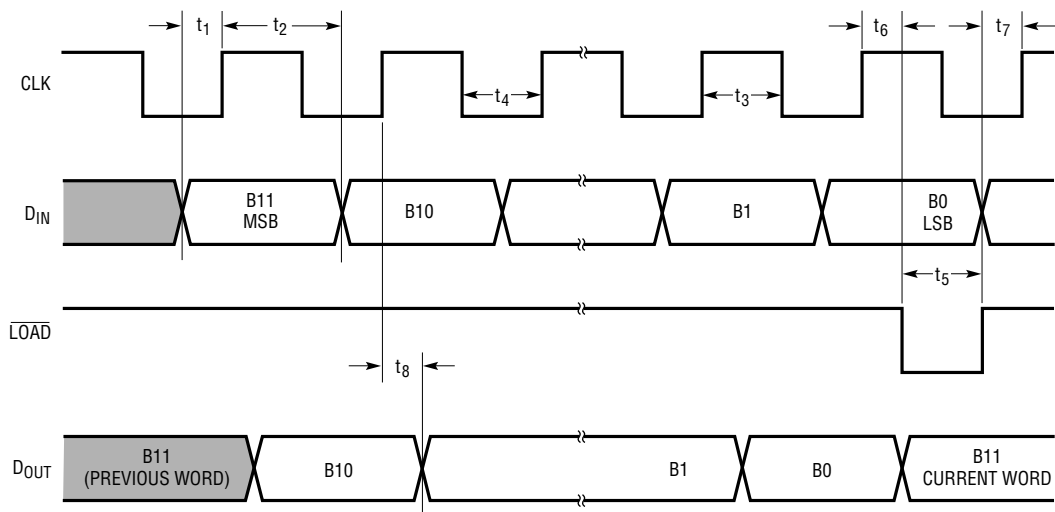

LTC1257

OPERATION

Serial Interface

The data on the D_{IN} input is loaded into the shift register on the rising edge of the clock. The MSB is loaded first and the LSB last. The DAC register loads the data from the shift register when \overline{LOAD} is pulled low, and remains transparent until \overline{LOAD} is pulled high and the data is latched.

An internal 5V regulator provides the supply for the digital logic. By limiting the internal digital signal swings to 5V, digital noise is reduced. The buffered output of the 12-bit shift register is available on the D_{OUT} pin which will swing from GND to V_{CC} .

Multiple LTC1257s may be daisy chained together by connecting the D_{OUT} pin to the D_{IN} pin of the next chip, while the clock and load signals remain common to all chips in the daisy chain. The serial data is clocked to all of the chips, then the \overline{LOAD} signal is pulled low to update all of them simultaneously. The maximum clocking rate is 1.4MHz.

Reference

The LTC1257 includes an internal 2.048V reference, making 1LSB equal to $500\mu V$. The internal reference output is turned off when the pin is forced above the reference voltage, allowing an external reference to be connected to the reference pin. The external reference must be greater than 2.475V and less than $V_{CC} - 2.7V$, and be capable of driving the 10k minimum DAC resistor ladder.

If the reference output is driving a large capacitive load, a series resistor must be added to insure stability. For any capacitive load greater than $1\mu F$, a 10Ω series resistor will suffice.

Voltage Output

The LTC1257 voltage output is able to pull within 2.7V of V_{CC} while sourcing 2mA. A internal NMOS transistor with a 200Ω equivalent impedance pulls the output to ground. The output is protected against short circuits and is able to drive up to a 500pF capacitive load without oscillation. If digital noise on the output causes a problem, a simple 100Ω , $0.1\mu F$ RC circuit can be used to filter the noise.

TYPICAL APPLICATIONS

DAC with External Reference

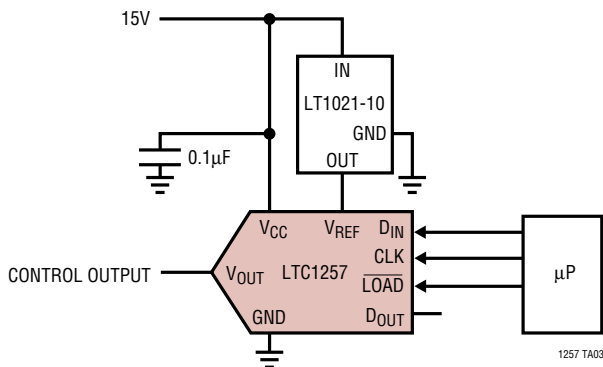

Filtering V_{REF} and V_{OUT}

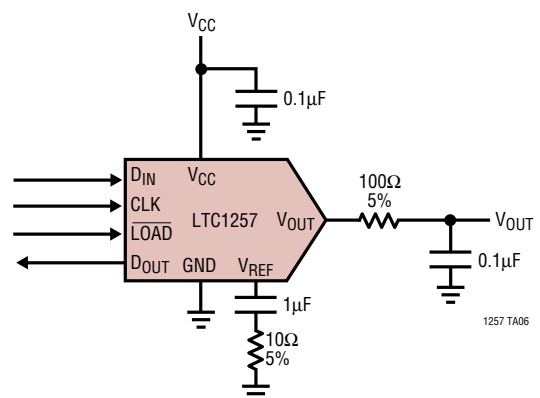

TYPICAL APPLICATIONS

Auto Ranging 8-Channel ADC with Shutdown

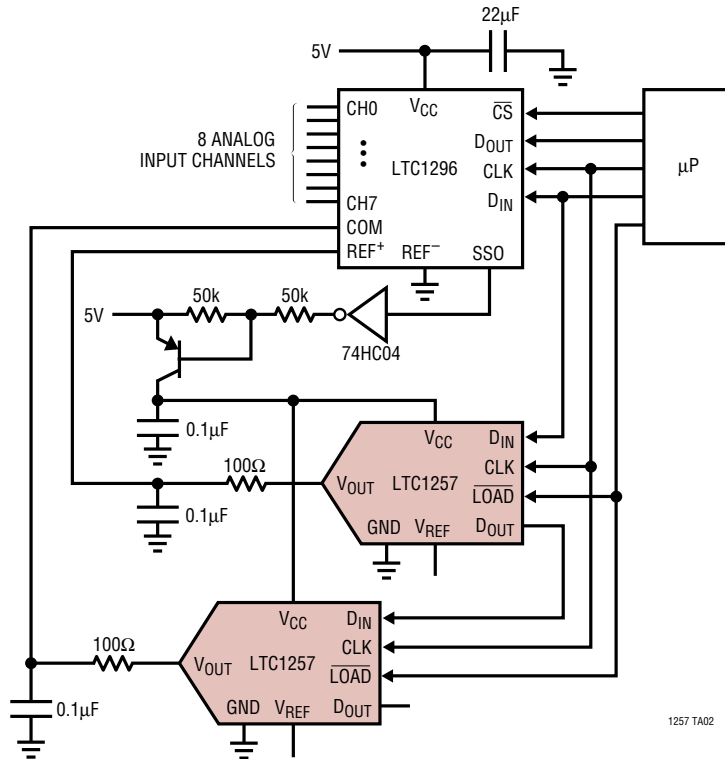

12-Bit Single 5V Control System with Shutdown

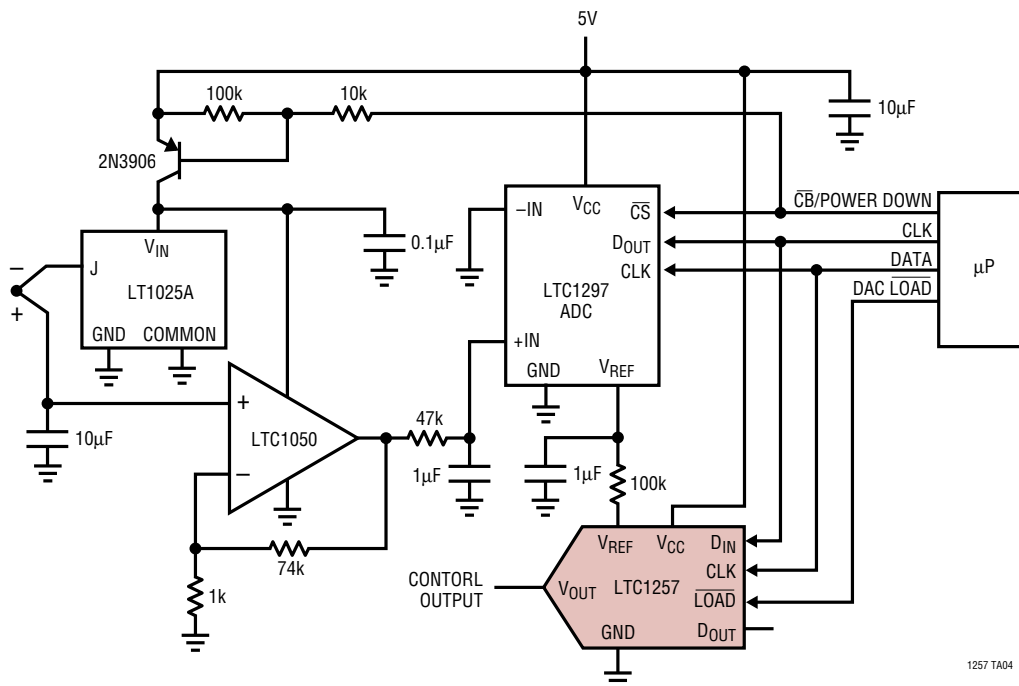

PACKAGE DESCRIPTION Dimensions in inches (millimeters) unless otherwise noted.

N8 Package
8-Lead PDIP (Narrow 0.300)
 (LTC DWG # 05-08-1510)

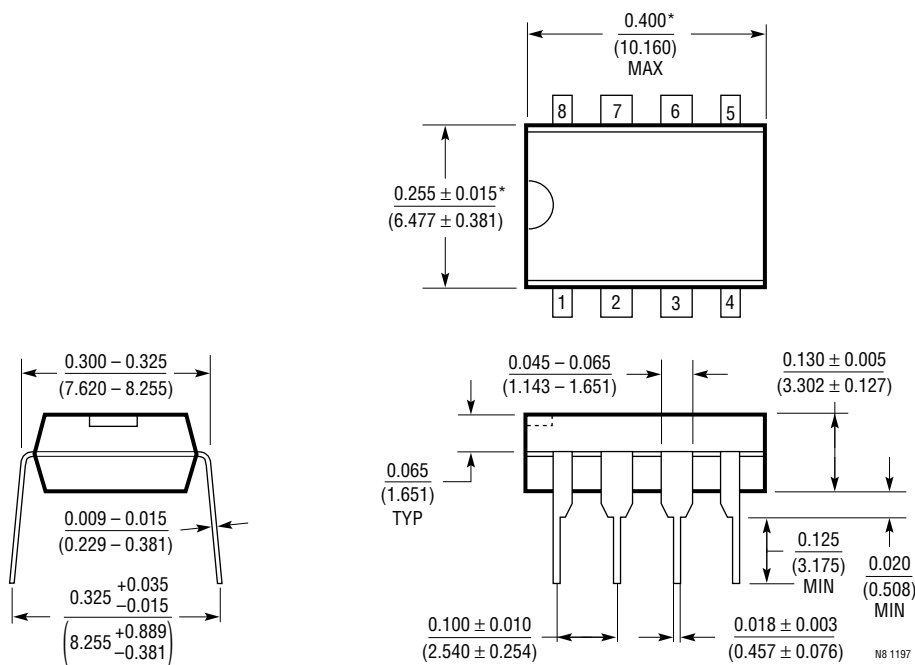

*THESE DIMENSIONS DO NOT INCLUDE MOLD FLASH OR PROTRUSIONS.
 MOLD FLASH OR PROTRUSIONS SHALL NOT EXCEED 0.010 INCH (0.254mm)

N8 1197

PACKAGE DESCRIPTION Dimensions in inches (millimeters) unless otherwise noted.

S8 Package 8-Lead Plastic Small Outline (Narrow 0.150) (LTC DWG # 05-08-1610)

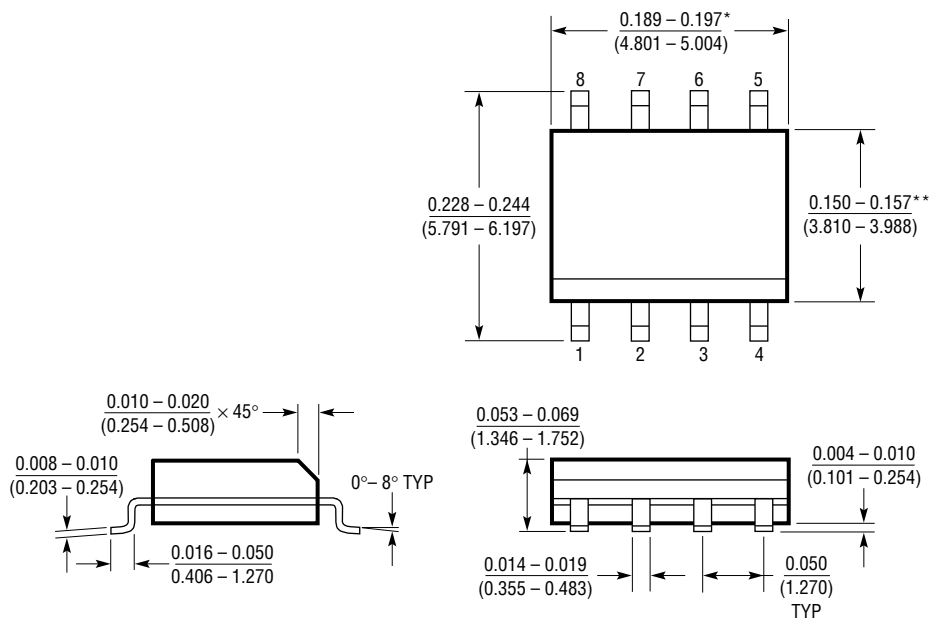

* DIMENSION DOES NOT INCLUDE MOLD FLASH. MOLD FLASH SHALL NOT EXCEED 0.006" (0.152mm) PER SIDE

** DIMENSION DOES NOT INCLUDE INTERLEAD FLASH. INTERLEAD FLASH SHALL NOT EXCEED 0.010" (0.254mm) PER SIDE

S08 0996

TYPICAL APPLICATION

Driving LTC1257 with Optoisolators

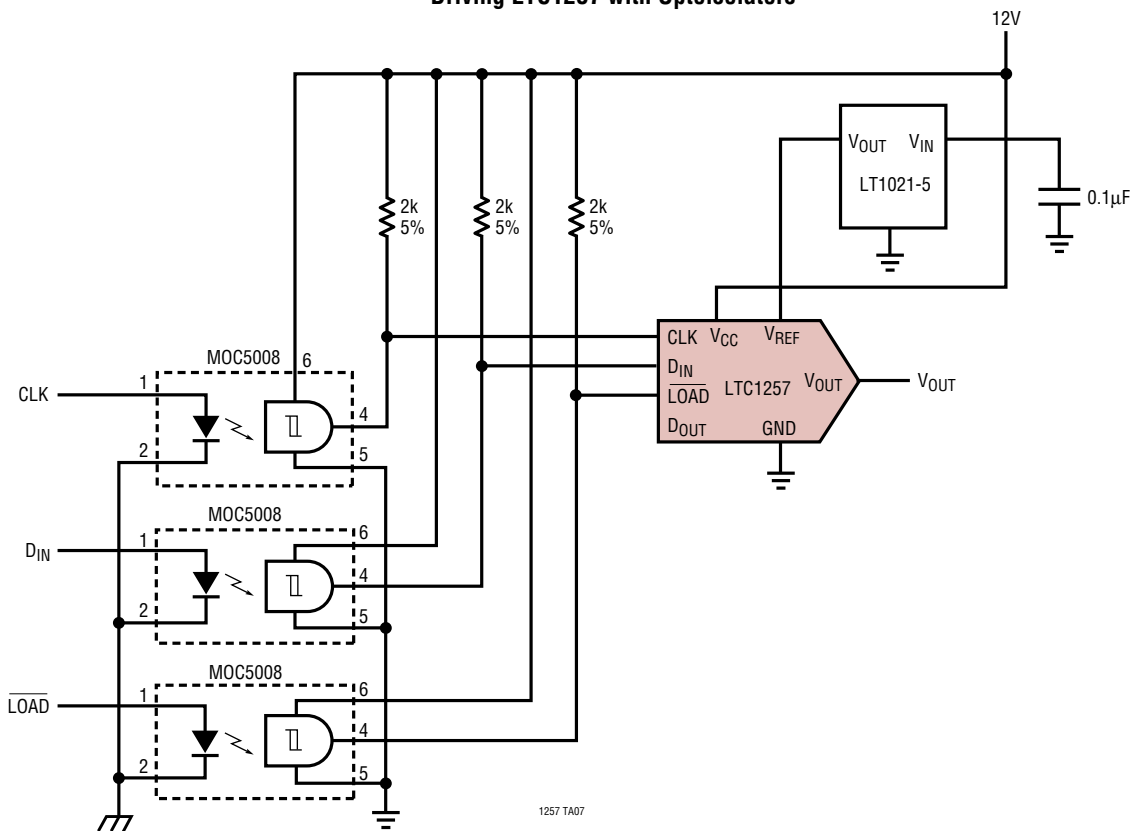

RELATED PARTS

PART NUMBER	DESCRIPTION	COMMENTS
LTC1446/LTC1446L	Dual 12-Bit V _{OUT} DACs in SO-8 Package	LTC1446: V _{CC} = 4.5V to 5.5V, V _{OUT} = 0V to 4.095V LTC1446L: V _{CC} = 2.7V to 5.5V, V _{OUT} = 0V to 2.5V
LTC1448	Dual 12-Bit V _{OUT} DAC in SO-8 Package, V _{CC} : 2.7V to 5.5V	Output Swings from GND to REF, REF Input Can Be Tied to V _{CC}
LTC1450/LTC1450L	Single 12-Bit V _{OUT} DACs with Parallel Interface	LTC1450: V _{CC} = 4.5V to 5.5V, V _{OUT} = 0V to 4.095V LTC1450L: V _{CC} = 2.7V to 5.5V, V _{OUT} = 0V to 2.5V
LTC1451	Single Rail-to-Rail 12-Bit V _{OUT} DAC, Full Scale: 4.095V, V _{CC} : 4.5V to 5.5V, Internal 2.048V Reference Brought Out to Pin	Low Power, Complete V _{OUT} DAC in SO-8 Package
LTC1452	Single Rail-to-Rail 12-Bit V _{OUT} Multiplying DAC, V _{CC} : 2.7V to 5.5V	Low Power, Multiplying V _{OUT} DAC with Rail-to-Rail Buffer Amplifier in SO-8 Package
LTC1453	Single Rail-to-Rail 12-Bit V _{OUT} DAC, Full Scale: 2.5V, V _{CC} : 2.7V to 5.5V	3V, Low Power, Complete V _{OUT} DAC in SO-8 Package
LTC1454/LTC1454L	Dual 12-Bit V _{OUT} DACs in SO-16 Package with Added Functionality	LTC1454: V _{CC} = 4.5V to 5.5V, V _{OUT} = 0V to 4.095V LTC1454L: V _{CC} = 2.7V to 5.5V, V _{OUT} = 0V to 2.5V
LTC1456	Single Rail-to-Rail Output 12-Bit DAC with Clear Pin, Full Scale: 4.095V, V _{CC} : 4.5V to 5.5V	Low Power, Complete V _{OUT} DAC in SO-8 Package with Clear Pin
LTC1458/LTC1458L	Quad 12 Bit Rail-to-Rail Output DACs with Added Functionality	LTC1458: V _{CC} = 4.5V to 5.5V, V _{OUT} = 0V to 4.095V LTC1458L: V _{CC} = 2.7V to 5.5V, V _{OUT} = 0V to 2.5V
LTC1659	Single Rail-to-Rail 12-Bit V _{OUT} DAC in MSOP-8 Package, V _{CC} = 2.7V to 5.5V	Output Swings from GND to REF, REF Input Can Be Tied to V _{CC}