

DUAL-OUTPUT LOW-DROPOUT VOLTAGE REGULATORS

SLVS209B – JULY 1999 – REVISED APRIL 2000

- Dual Output Voltages for Split-Supply Applications
- Output Current Range of 0 mA to 1.0 A Per Regulator
- 3.3-V/2.5-V, 3.3-V/1.8-V, and 3.3-V/Adjustable Output
- Fast-Transient Response
- 2% Tolerance Over Load and Temperature
- Dropout Voltage Typically 350 mV at 1 A
- Ultra Low 85 μ A Typical Quiescent Current
- 1 μ A Quiescent Current During Shutdown
- Dual Open Drain Power-On Reset With 200-ms Delay for Each Regulator
- 28-Pin PowerPAD™ TSSOP Package
- Thermal Shutdown Protection for Each Regulator

PWP PACKAGE
(TOP VIEW)

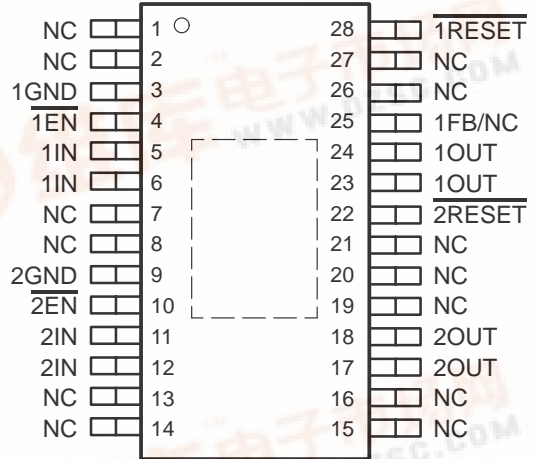

NC – No internal connection

description

The TPS767D3xx family of dual voltage regulators offers fast transient response, low dropout voltages and dual outputs in a compact package and incorporating stability with 10- μ F low ESR output capacitors.

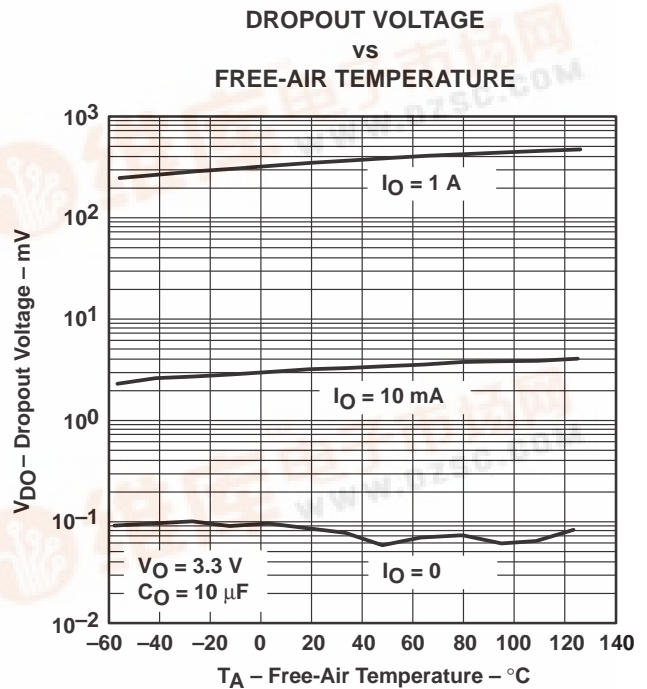
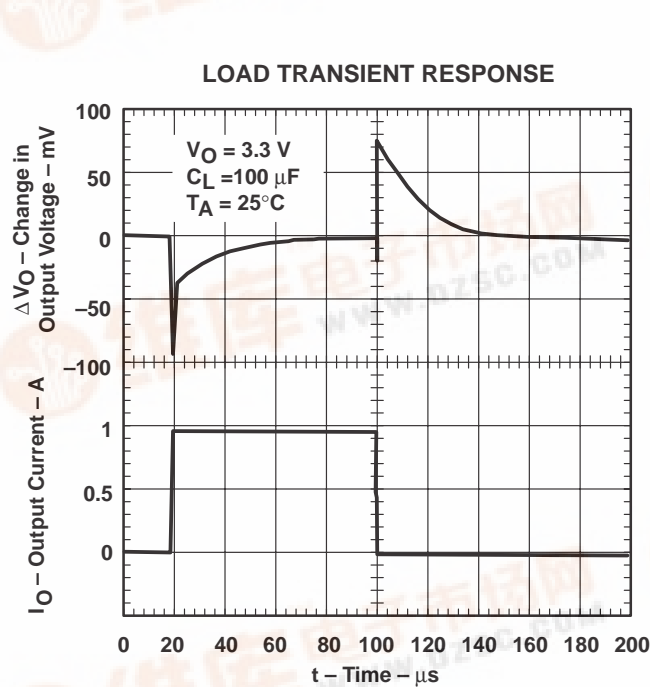

Please be aware that an important notice concerning availability, standard warranty, and use in critical applications of Texas Instruments semiconductor products and disclaimers thereto appears at the end of this data sheet.

PowerPAD is a trademark of Texas Instruments Incorporated.

PRODUCTION DATA information is current as of publication date. Products conform to specifications per the terms of Texas Instruments standard warranty. Production processing does not necessarily include testing of all parameters.

Copyright © 2000, Texas Instruments Incorporated

TPS767D301, TPS767D318, TPS767D325 DUAL-OUTPUT LOW-DROPOUT VOLTAGE REGULATORS

SLVS209B – JULY 1999 – REVISED APRIL 2000

description (continued)

The TPS767D3xx family of dual voltage regulators is designed primarily for DSP applications. These devices can be used in any mixed-output voltage application, with each regulator supporting up to 1 A. Dual active-low reset signals allow resetting of core-logic and I/O separately.

Because the PMOS device behaves as a low-value resistor, the dropout voltage is very low (typically 350 mV at an output current of 1 A for the TPS767D325) and is directly proportional to the output current. Additionally, since the PMOS pass element is a voltage-driven device, the quiescent current is very low and independent of output loading (typically 85 μ A over the full range of output current, 0 mA to 1 A). These two key specifications yield a significant improvement in operating life for battery-powered systems. This LDO family also features a sleep mode; applying a TTL high signal to \overline{EN} (enable) shuts down the regulator, reducing the quiescent current to 1 μ A at $T_J = 25^\circ\text{C}$.

The \overline{RESET} output of the TPS767D3xx initiates a reset in microcomputer and microprocessor systems in the event of an undervoltage condition. An internal comparator in the TPS767D3xx monitors the output voltage of the regulator to detect an undervoltage condition on the regulated output voltage.

The TPS767D3xx is offered in 1.8-V, 2.5-V, and 3.3-V fixed-voltage versions and in an adjustable version (programmable over the range of 1.5 V to 5.5 V). Output voltage tolerance is specified as a maximum of 2% over line, load, and temperature ranges. The TPS767D3xx family is available in 28 pin PWP TSSOP package. They operate over a junction temperature range of -40°C to 125°C .

AVAILABLE OPTIONS

T_A	REGULATOR 1 V_O (V)	REGULATOR 2 V_O (V)	TSSOP (PWP)
-40°C to 125°C	Adj (1.5 – 5.5 V)	3.3 V	TPS767D301PWP
	1.8 V	3.3 V	TPS767D318PWP
	2.5 V	3.3 V	TPS767D325PWP

The TPS767D301 is adjustable using an external resistor divider (see application information). The PWP packages are available taped and reeled. Add an R suffix to the device type (e.g., TPS767D301PWPR).

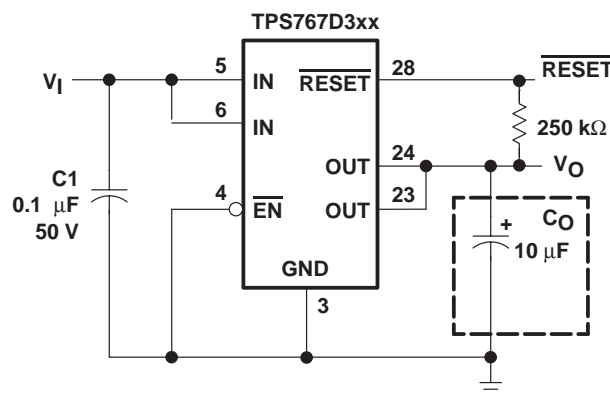
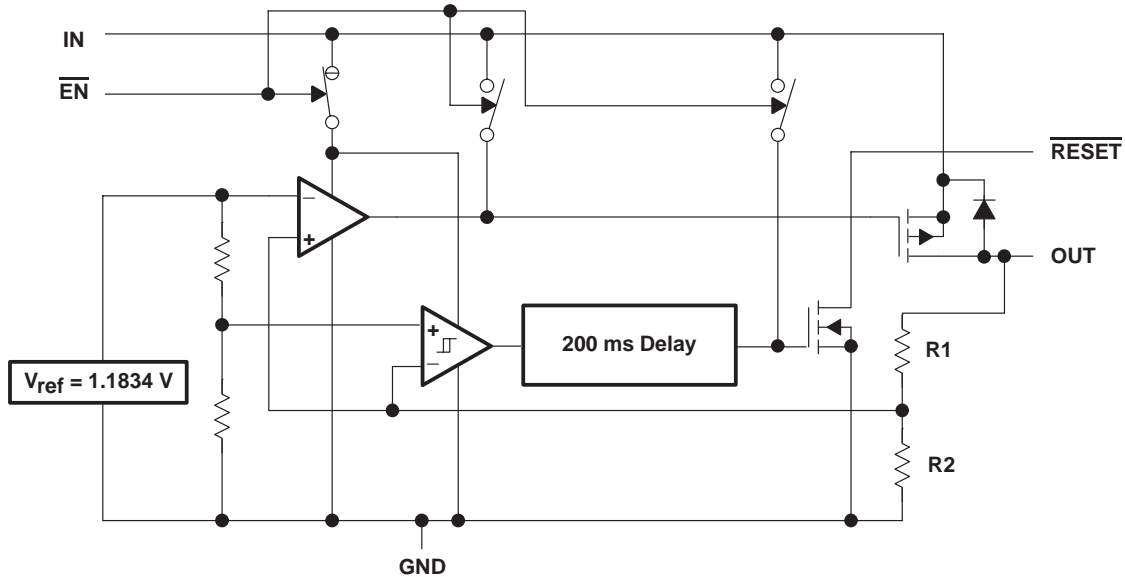

Figure 1. Typical Application Circuit (Fixed Versions) for Single Channel

TPS767D301, TPS767D318, TPS767D325 DUAL-OUTPUT LOW-DROPOUT VOLTAGE REGULATORS

SLVS209B – JULY 1999 – REVISED APRIL 2000

functional block diagram—adjustable version (for each LDO)



functional block diagram—fixed-voltage version (for each LDO)

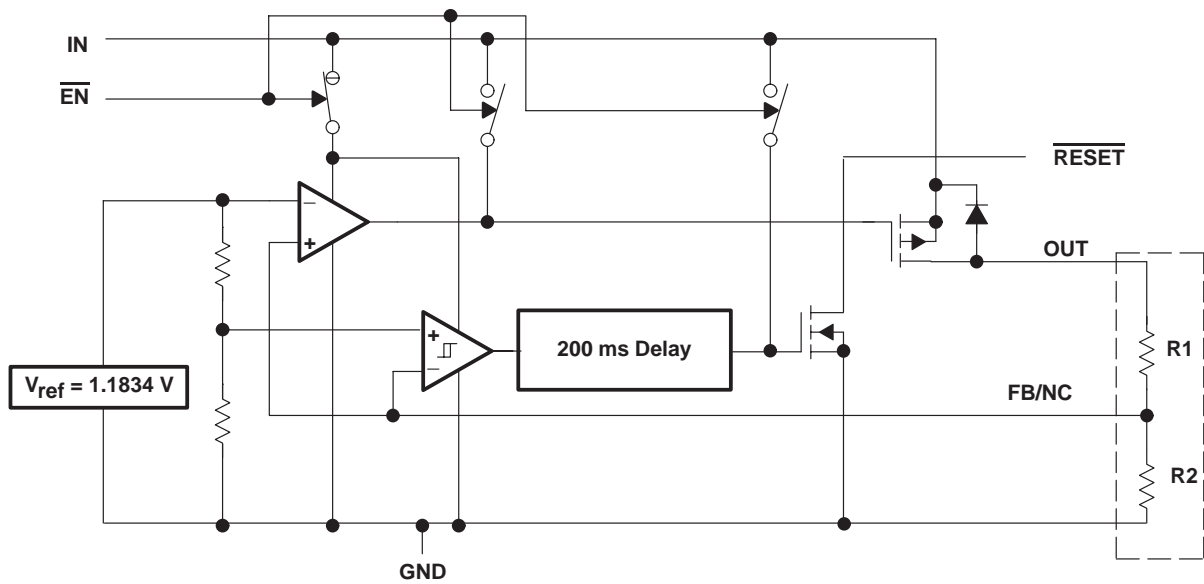

External to the device

TPS767D301, TPS767D318, TPS767D325 DUAL-OUTPUT LOW-DROPOUT VOLTAGE REGULATORS

SLVS209B – JULY 1999 – REVISED APRIL 2000

Terminal Functions

TERMINAL NAME	TERMINAL NO.	I/O	DESCRIPTION
1GND	3		Regulator #1 ground
1EN	4	I	Regulator #1 enable
1IN	5, 6	I	Regulator #1 input supply voltage
2GND	9		Regulator #2 ground
2EN	10	I	Regulator #2 enable
2IN	11, 12	I	Regulator #2 input supply voltage
2OUT	17, 18	O	Regulator #2 output voltage
2RESET	22	O	Regulator #2 reset signal
1OUT	23, 24	O	Regulator #1 output voltage
1FB/NC	25	I	Regulator #1 output voltage feedback for adjustable and no connect for fixed output
1RESET	28	O	Regulator #1 reset signal
NC	1, 2, 7, 8, 13–16, 19, 20, 21, 26, 27		No connection

timing diagram

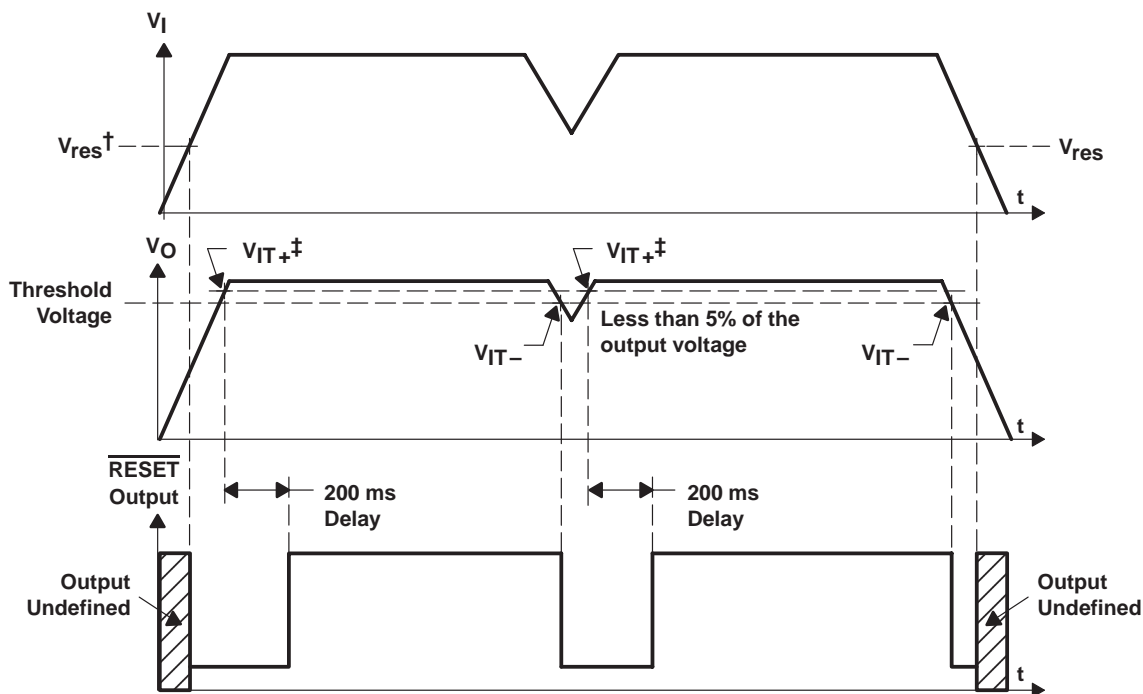

† V_{res} is the minimum input voltage for a valid \overline{RESET} . The symbol V_{res} is not currently listed within EIA or JEDEC standards for semiconductor symbology.

‡ V_{IT-} Trip voltage is typically 5% lower than the output voltage ($95\%V_O$)

TPS767D301, TPS767D318, TPS767D325 DUAL-OUTPUT LOW-DROPOUT VOLTAGE REGULATORS

SLVS209B – JULY 1999 – REVISED APRIL 2000

absolute maximum ratings over operating free-air temperature (unless otherwise noted)†

Input voltage range‡, V_I	–0.3 V to 13.5 V
Input voltage range, V_I (1IN, 2IN, \overline{EN})	–0.3 V to $V_I + 0.3$ V
Output voltage, V_O (1OUT, 2OUT)	7 V
Output voltage, V_O (RESET)	16.5 V
Peak output current	Internally limited
ESD rating, HBM	2 kV
Continuous total power dissipation	See dissipation rating tables
Operating virtual junction temperature range, T_J	–40°C to 125°C
Storage temperature range, T_{stg}	–65°C to 150°C

† Stresses beyond those listed under “absolute maximum ratings” may cause permanent damage to the device. These are stress ratings only, and functional operation of the device at these or any other conditions beyond those indicated under “recommended operating conditions” is not implied. Exposure to absolute-maximum-rated conditions for extended periods may affect device reliability.

‡ All voltage values are with respect to network terminal ground.

DISSIPATION RATING TABLE

PACKAGE	AIR FLOW (CFM)	$T_A \leq 25^\circ\text{C}$ POWER RATING	DERATING FACTOR ABOVE $T_A = 25^\circ\text{C}$	$T_A = 70^\circ\text{C}$ POWER RATING	$T_A = 85^\circ\text{C}$ POWER RATING
PWP†	0	3.58 W	35.8 mW/°C	1.97 W	1.43 W
	250	5.07 W	50.7 mW/°C	2.79 W	2.03 W

† This parameter is measured with the recommended copper heat sink pattern on a 4-layer PCB, 1 oz. copper on 4-in x 4-in ground layer. For more information, refer to TI technical brief literature number SLMA002.

recommended operating conditions

	MIN	MAX	UNIT
Input voltage, V_I # (1IN, 2IN)	2.7	10	V
Output current for each LDO, I_O (Note 1)	0	1.0	A
Output voltage range, V_O (1OUT, 2OUT)	1.5	5.5	V
Operating virtual junction temperature, T_J	–40	125	°C

To calculate the minimum input voltage for your maximum output current, use the following equation: $V_{I(\min)} = V_{O(\max)} + V_{DO(\max \text{ load})}$.

NOTE 1: Continuous current and operating junction temperature are limited by internal protection circuitry, but it is not recommended that the device operate under conditions beyond those specified in this table for extended periods of time.

TPS767D301, TPS767D318, TPS767D325 DUAL-OUTPUT LOW-DROPOUT VOLTAGE REGULATORS

SLVS209B – JULY 1999 – REVISED APRIL 2000

electrical characteristics, $V_i = V_{O(nom)} + 1\text{ V}$, $I_O = 1\text{ mA}$, $\overline{EN} = 0$, $C_O = 10\text{ }\mu\text{F}$ (unless otherwise noted)

PARAMETER		TEST CONDITIONS		MIN	TYP	MAX	UNIT
Output voltage (V_O) (see Note 2)	Adjustable	$1.5\text{ V} \leq V_O \leq 5.5\text{ V}$, $10\text{ }\mu\text{A} < I_O < 1\text{ A}$	$T_J = 25^\circ\text{C}$	V_O			V
			$T_J = -40^\circ\text{C to } 125^\circ\text{C}$	$0.98V_O$	$1.02V_O$		
	1.8 V Output	$2.8\text{ V} < V_I < 10\text{ V}$, $10\text{ }\mu\text{A} < I_O < 1\text{ A}$	$T_J = 25^\circ\text{C}$	1.8			
			$T_J = -40^\circ\text{C to } 125^\circ\text{C}$	1.764	1.836		
	2.5 V Output	$3.5\text{ V} < V_I < 10\text{ V}$, $10\text{ }\mu\text{A} < I_O < 1\text{ A}$	$T_J = 25^\circ\text{C}$	2.5			
			$T_J = -40^\circ\text{C to } 125^\circ\text{C}$	2.45	2.55		
3.3 V Output	$4.3\text{ V} < V_I < 10\text{ V}$, $10\text{ }\mu\text{A} < I_O < 1\text{ A}$	$T_J = 25^\circ\text{C}$	3.3				
		$T_J = -40^\circ\text{C to } 125^\circ\text{C}$	3.234	3.366			
Quiescent current (GND current) for each LDO (see Note 2)		$10\text{ }\mu\text{A} < I_O < 1\text{ A}$, $T_J = 25^\circ\text{C}$	85			μA	
		$I_O = 1\text{ A}$, $T_J = -40^\circ\text{C to } 125^\circ\text{C}$			125		
Output voltage line regulation for each LDO ($\Delta V_O/V_O$) (see Notes 2 and 3)		$V_O + 1\text{ V} < V_I \leq 10\text{ V}$, $T_J = 25^\circ\text{C}$	0.01			%/V	
Output noise voltage		BW = 300 Hz to 50 kHz, $C_O = 10\text{ }\mu\text{F}$, $T_J = 25^\circ\text{C}$	190			μV_{rms}	
Output current Limit for each LDO		$V_O = 0\text{ V}$	1.7		2	A	
Thermal shutdown junction temperature			150			$^\circ\text{C}$	
Standby current for each LDO		$2.7 < V_I < 10\text{ V}$, $T_J = 25^\circ\text{C}$, $\overline{EN} = V_I$	1			μA	
		$2.7 < V_I < 10\text{ V}$, $T_J = -40^\circ\text{C to } 125^\circ\text{C}$, $\overline{EN} = V_I$			10	μA	
FB input current	Adjustable	FB = 1.5 V	2			nA	
High level enable input voltage			2.0			V	
Low level enable input voltage					0.8	V	
Power supply ripple rejection (see Note 2)		$f = 1\text{ KHz}$, $T_J = 25^\circ\text{C}$, $C_O = 10\text{ }\mu\text{F}$	60			dB	
Reset	Minimum input voltage for valid $\overline{\text{RESET}}$		$I_O(\text{RESET}) = 300\text{ }\mu\text{A}$		1.1	V	
	Trip threshold voltage		V_O decreasing		92	98	% V_O
	Hysteresis voltage		Measured at V_O		0.5		% V_O
	Output low voltage		$V_I = 2.7\text{ V}$, $I_O(\text{RESET}) = 1\text{ mA}$	0.15	0.4		V
	Leakage current		$V(\text{RESET}) = 7\text{ V}$			1	μA
	RESET time-out delay			200			mA

NOTES: 2. Minimum IN operating voltage is 2.7 V or $V_{O(\text{typ})} + 1\text{ V}$, whichever is greater. maximum IN voltage 10V.

3. If $V_O \leq 1.8\text{ V}$, $V_{\text{imin}} = 2.7\text{ V}$, and $V_{\text{imax}} = 10\text{ V}$:

$$\text{Line Reg. (mV)} = (\%/V) \times \frac{V_O(V_{\text{imax}} - 2.7\text{ V})}{100} \times 1000$$

If $V_O \geq 2.5\text{ V}$, $V_{\text{imin}} = V_O + 1\text{ V}$, and $V_{\text{imax}} = 10\text{ V}$:

$$\text{Line Reg. (mV)} = (\%/V) \times \frac{V_O(V_{\text{imax}} - (V_O + 1\text{ V}))}{100} \times 1000$$

TPS767D301, TPS767D318, TPS767D325 DUAL-OUTPUT LOW-DROPOUT VOLTAGE REGULATORS

SLVS209B – JULY 1999 – REVISED APRIL 2000

**electrical characteristics, $V_i = V_{O(nom)} + 1\text{ V}$, $I_O = 1\text{ mA}$, $\overline{EN} = 0$, $C_O = 10\text{ }\mu\text{F}$ (unless otherwise noted)
(continued)**

PARAMETER	TEST CONDITIONS	MIN	TYP	MAX	UNIT
Input current (EN)	$\overline{EN} = 0\text{ V}$	-1	0	1	μA
	$\overline{EN} = V_i$	-1		1	
Load regulation			3		mV
Dropout voltage (see Note 4)	$V_O = 3.3\text{ V}$, $I_O = 1\text{ A}$	$T_J = 25^\circ\text{C}$	350		mV
		$T_J = -40^\circ\text{C to } 125^\circ\text{C}$		575	

NOTE 4: I_N voltage equals $V_O(\text{Typ}) - 100\text{mV}$; Adjustable output voltage set to 3.3V nominal with external resistor divider. 1.8V, and 2.5V dropout voltage is limited by input voltage range limitations.

TYPICAL CHARACTERISTICS

Table of Graphs

		FIGURE
Output voltage	vs Output current	2, 3, 4
	vs Free-air temperature	5, 6, 7
Ground current	vs Free-air temperature	8, 9
Power supply ripple rejection	vs Frequency	10
Output spectral noise density	vs Frequency	11
Output impedance	vs Frequency	12
Dropout voltage	vs Free-air temperature	13
Line transient response		14, 16
Load transient response		15, 17
Output voltage	vs Time	18
Dropout voltage	vs Input voltage	19
Equivalent series resistance (ESR)	vs Output current, $T_A = 25^\circ\text{C}$	21
	vs Output current, $T_J = 125^\circ\text{C}$	22
	vs Output Current, $T_A = 25^\circ\text{C}$	23
	vs Output current, $T_J = 125^\circ\text{C}$	24

TPS767D301, TPS767D318, TPS767D325 DUAL-OUTPUT LOW-DROPOUT VOLTAGE REGULATORS

SLVS209B – JULY 1999 – REVISED APRIL 2000

TYPICAL CHARACTERISTICS

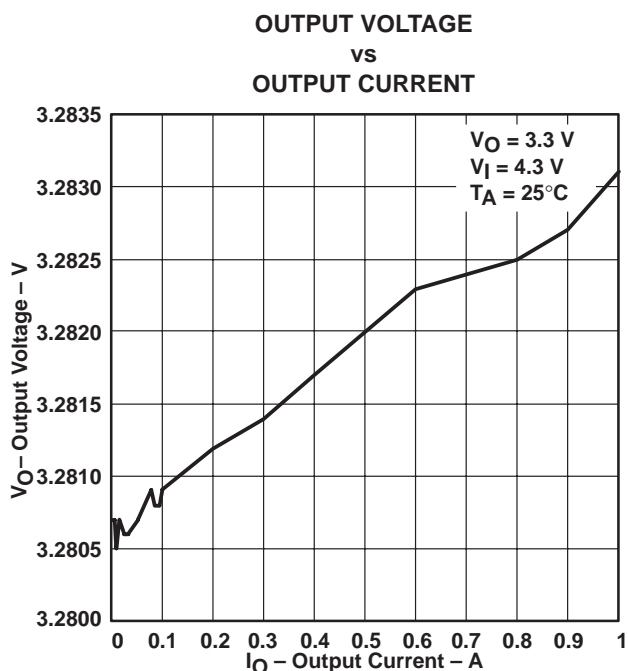

Figure 2

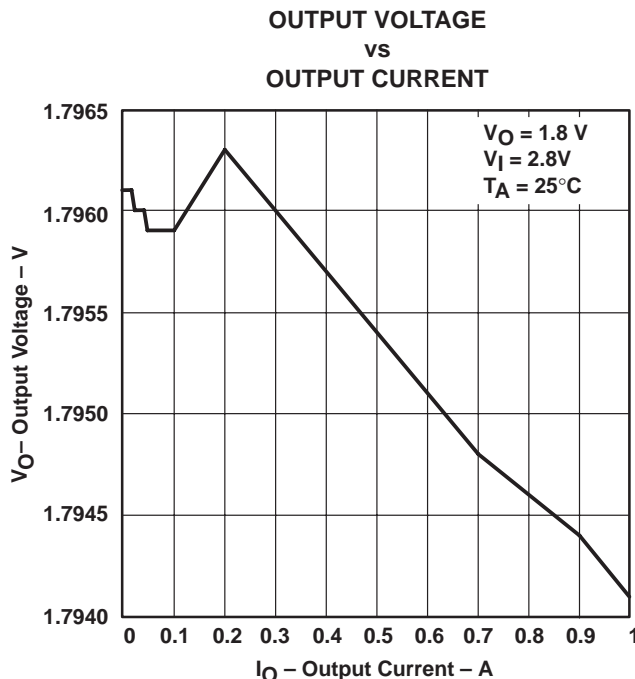

Figure 3

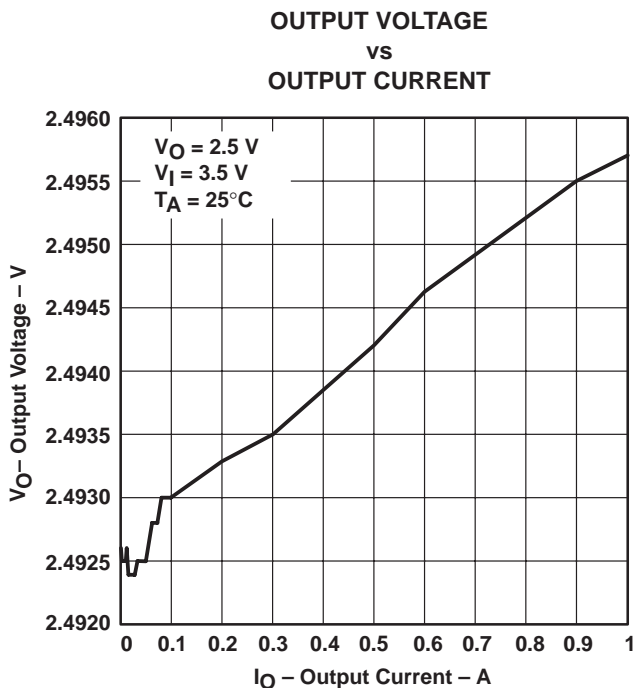

Figure 4

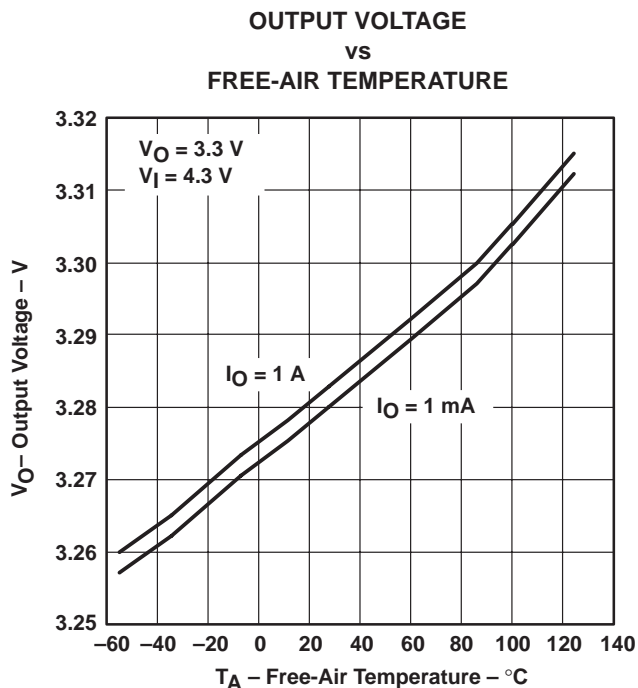

Figure 5

TPS767D301, TPS767D318, TPS767D325 DUAL-OUTPUT LOW-DROPOUT VOLTAGE REGULATORS

SLVS209B – JULY 1999 – REVISED APRIL 2000

TYPICAL CHARACTERISTICS

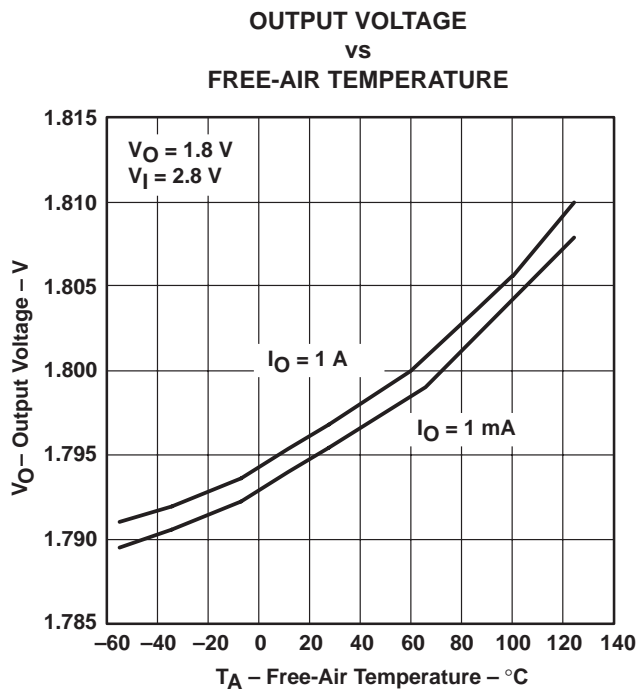

Figure 6

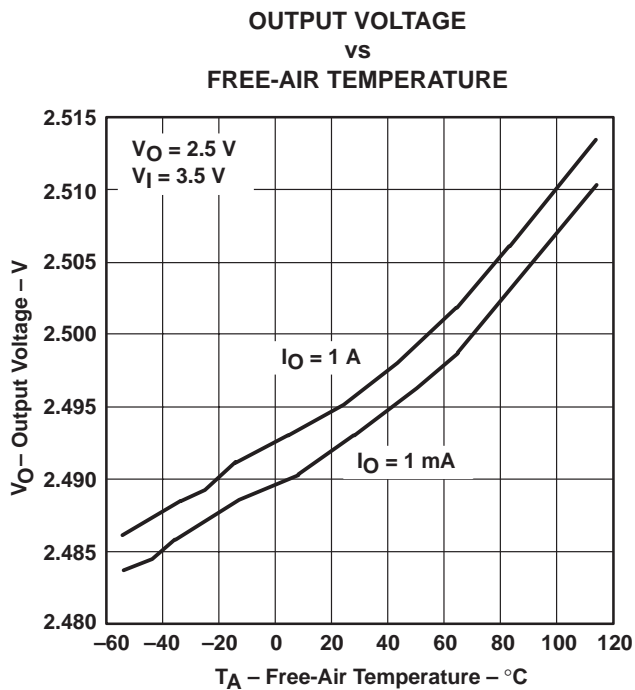

Figure 7

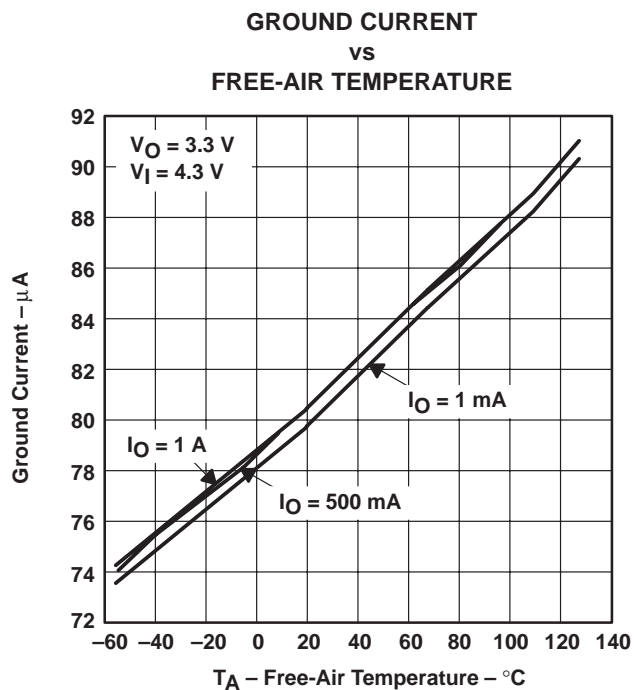

Figure 8

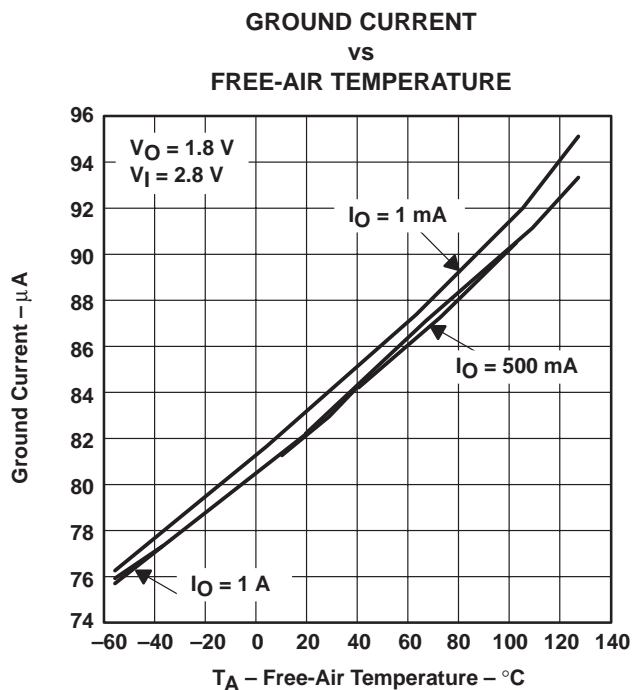

Figure 9

TPS767D301, TPS767D318, TPS767D325 DUAL-OUTPUT LOW-DROPOUT VOLTAGE REGULATORS

SLVS209B – JULY 1999 – REVISED APRIL 2000

TYPICAL CHARACTERISTICS

**POWER SUPPLY RIPPLE REJECTION
VS
FREQUENCY**

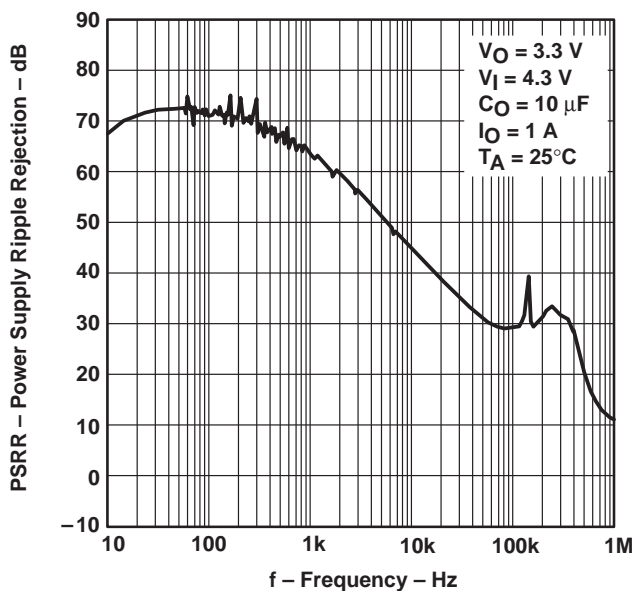

Figure 10

**OUTPUT SPECTRAL NOISE DENSITY
VS
FREQUENCY**

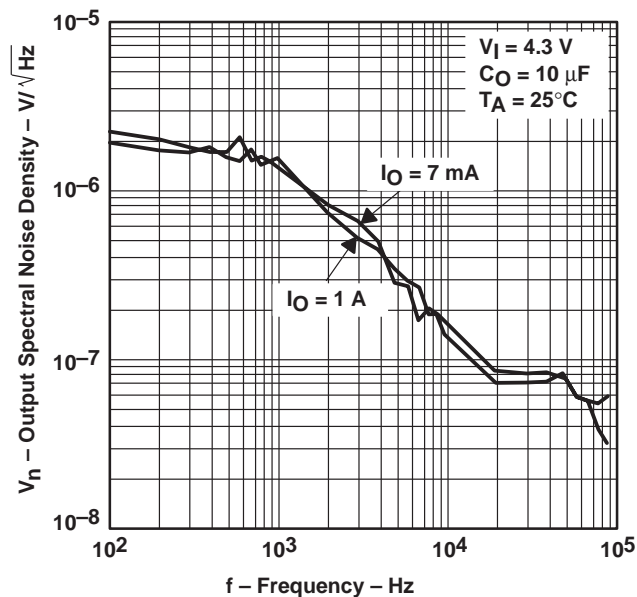

Figure 11

**OUTPUT IMPEDANCE
VS
FREQUENCY**

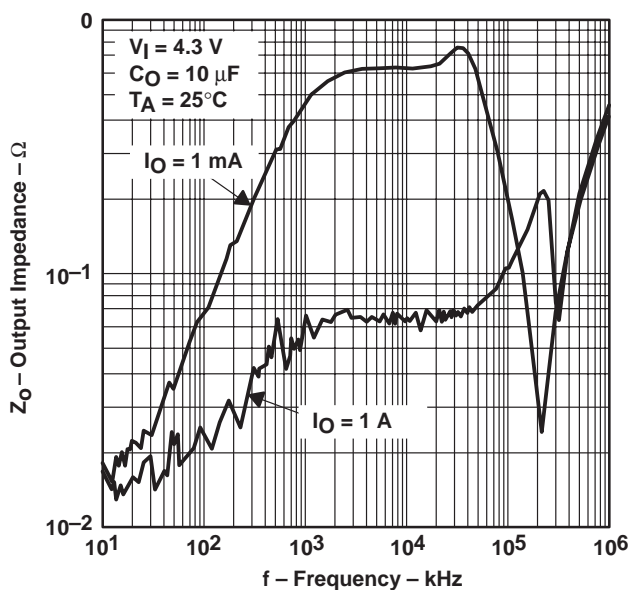

Figure 12

**DROPOUT VOLTAGE
VS
FREE-AIR TEMPERATURE**

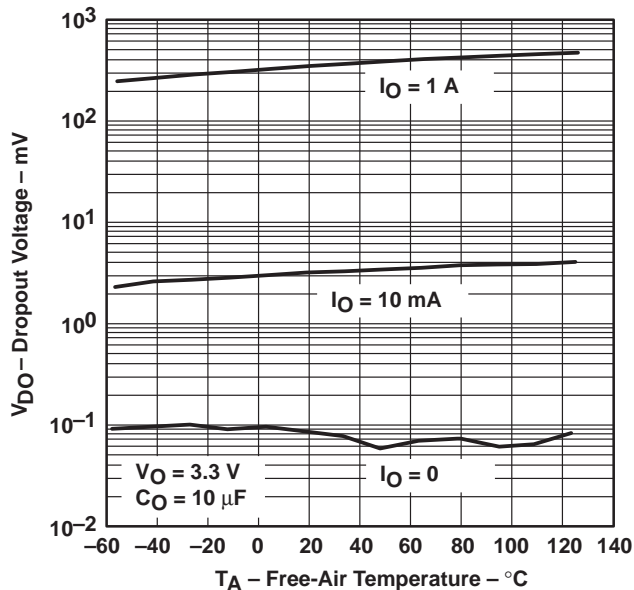

Figure 13

TPS767D301, TPS767D318, TPS767D325 DUAL-OUTPUT LOW-DROPOUT VOLTAGE REGULATORS

SLVS209B – JULY 1999 – REVISED APRIL 2000

TYPICAL CHARACTERISTICS

LINE TRANSIENT RESPONSE

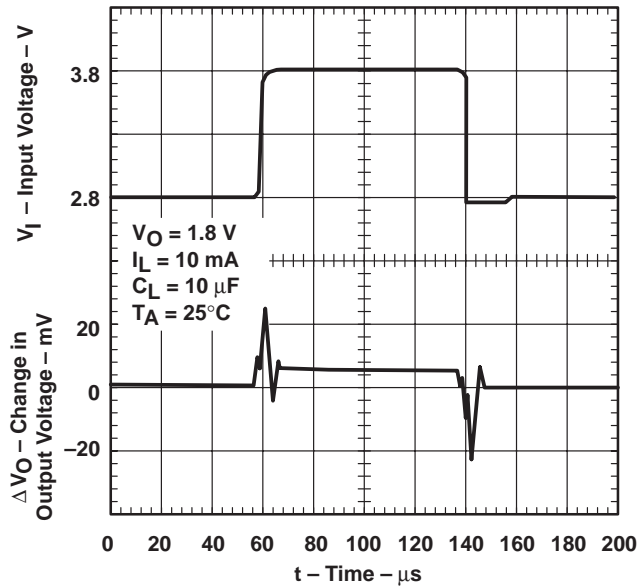

Figure 14

LOAD TRANSIENT RESPONSE

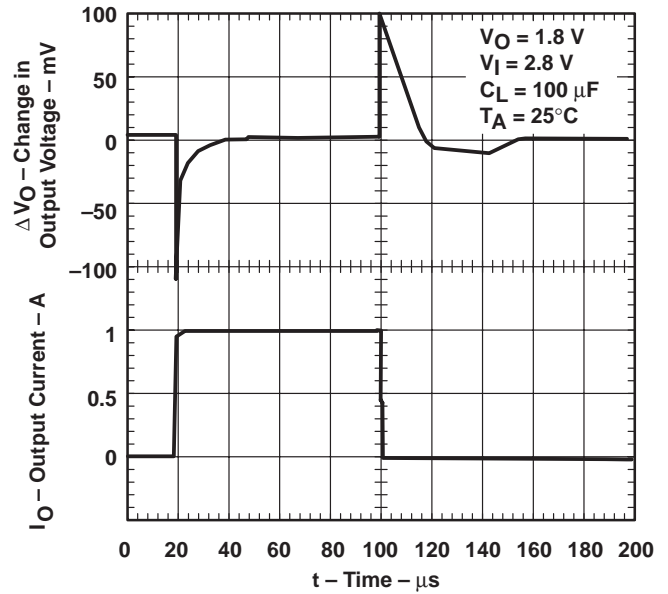

Figure 15

LINE TRANSIENT RESPONSE

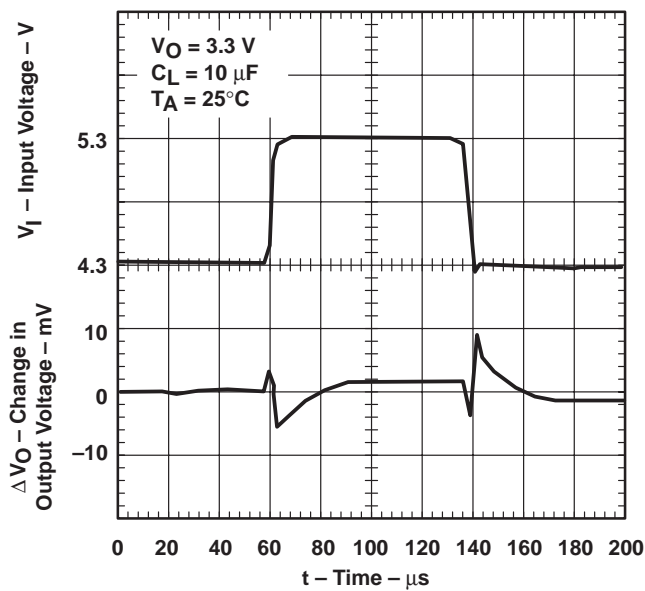

Figure 16

LOAD TRANSIENT RESPONSE

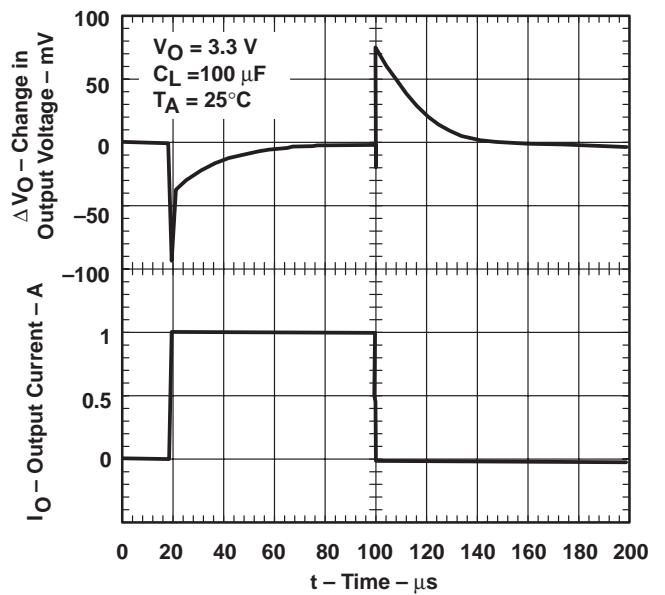

Figure 17

TPS767D301, TPS767D318, TPS767D325 DUAL-OUTPUT LOW-DROPOUT VOLTAGE REGULATORS

SLVS209B – JULY 1999 – REVISED APRIL 2000

TYPICAL CHARACTERISTICS

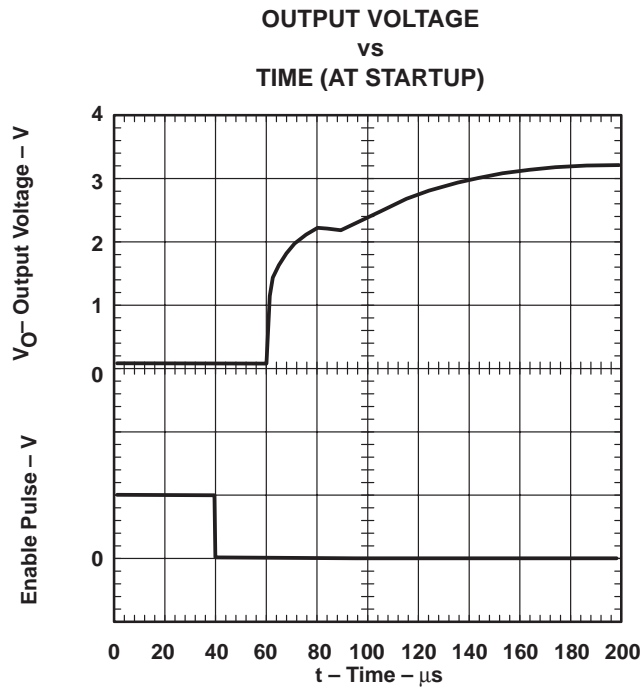

Figure 18

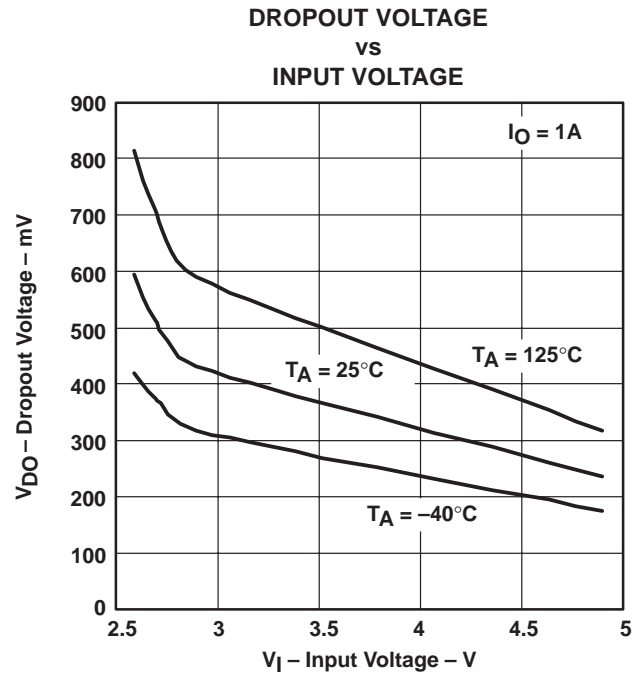

Figure 19

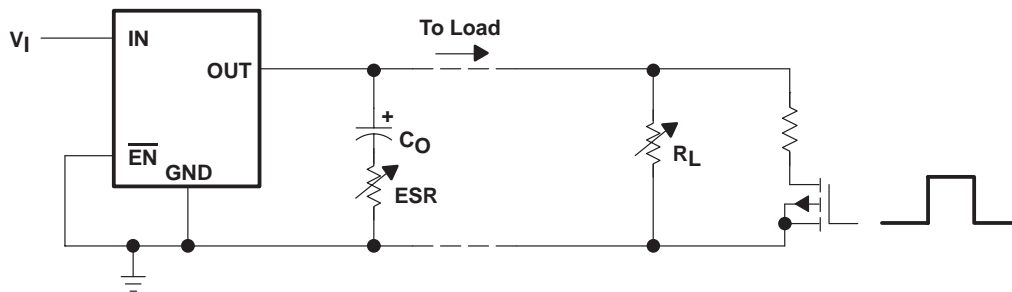

Figure 20. Test Circuit for Typical Regions of Stability (Figures 21 through 24) (fixed output options)

TPS767D301, TPS767D318, TPS767D325 DUAL-OUTPUT LOW-DROPOUT VOLTAGE REGULATORS

SLVS209B – JULY 1999 – REVISED APRIL 2000

TYPICAL CHARACTERISTICS

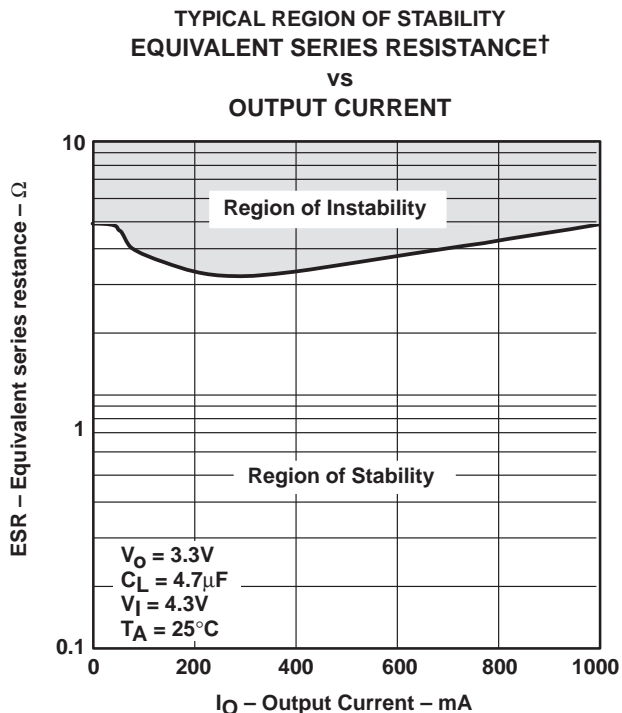

Figure 21

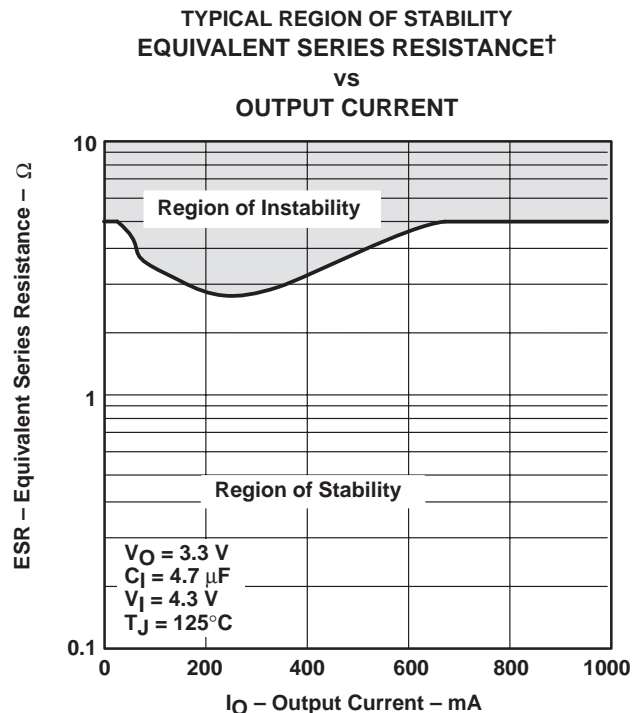

Figure 22

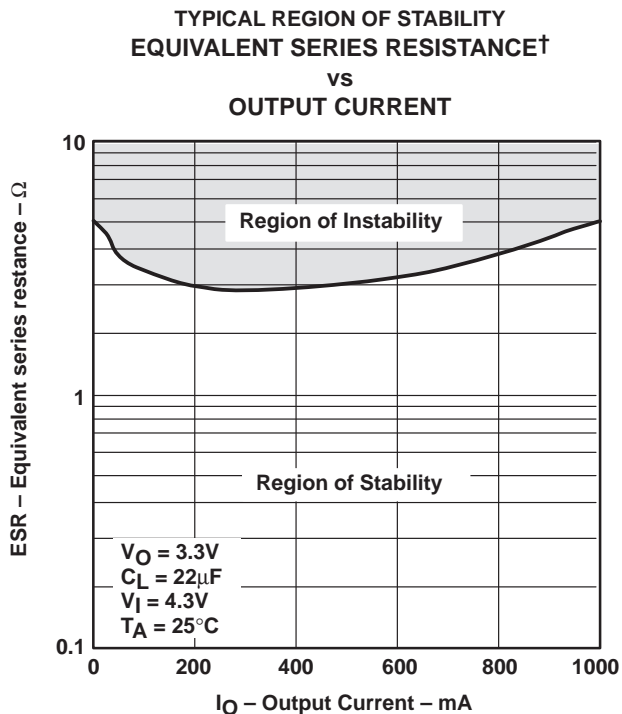

Figure 23

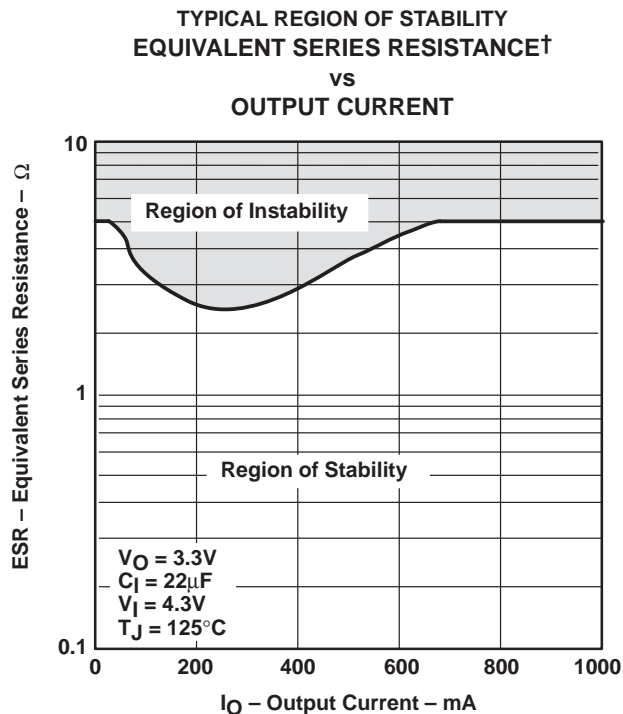

Figure 24

† Equivalent series resistance (ESR) refers to the total series resistance, including the ESR of the capacitor, any series resistance added externally, and PWB trace resistance to C_O .

TPS767D301, TPS767D318, TPS767D325 DUAL-OUTPUT LOW-DROPOUT VOLTAGE REGULATORS

SLVS209B – JULY 1999 – REVISED APRIL 2000

APPLICATION INFORMATION

The features of the TPS767D3xx family (low-dropout voltage, ultra low quiescent current, power-saving shutdown mode, and a supply-voltage supervisor) and the power-dissipation properties of the TSSOP PowerPAD package have enabled the integration of the dual LDO regulator with high output current for use in DSP and other multiple voltage applications. Figure 25 shows a typical dual-voltage DSP application.

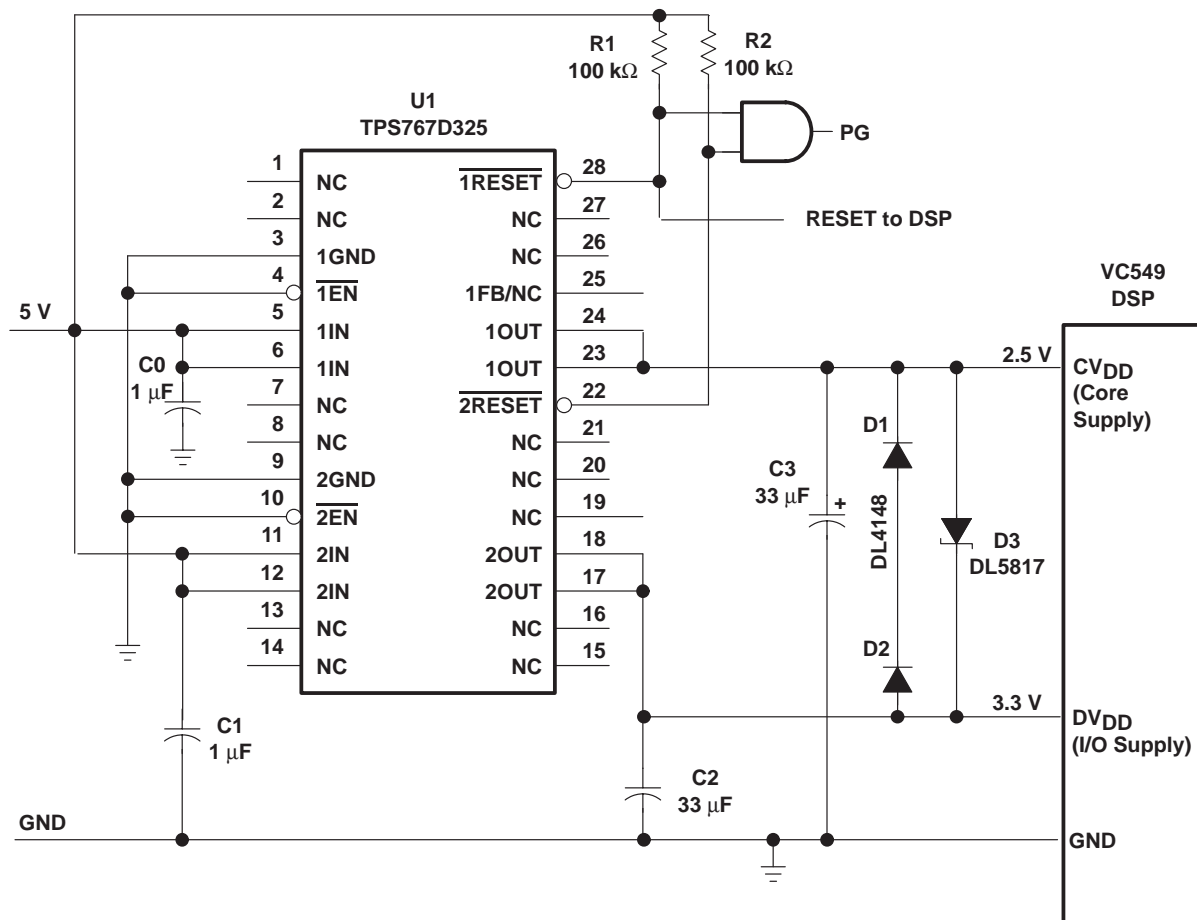

Figure 25. Dual-Voltage DSP Application

DSP power requirements include very high transient currents that must be considered in the initial design. This design uses higher-valued output capacitors to handle the large transient currents.

device operation

The TPS767D3xx features very low quiescent current, which remain virtually constant even with varying loads. Conventional LDO regulators use a pnp pass element, the base current of which is directly proportional to the load current through the regulator ($I_B = I_C/\beta$). Close examination of the data sheets reveals that these devices are typically specified under near no-load conditions; actual operating currents are much higher as evidenced by typical quiescent current versus load current curves. The TPS767D3xx uses a PMOS transistor to pass current; because the gate of the PMOS is voltage driven, operating current is low and invariable over the full load range. The TPS767D3xx specifications reflect actual performance under load condition.

TPS767D301, TPS767D318, TPS767D325 DUAL-OUTPUT LOW-DROPOUT VOLTAGE REGULATORS

SLVS209B – JULY 1999 – REVISED APRIL 2000

Another pitfall associated with the pnp-pass element is its tendency to saturate when the device goes into dropout. The resulting drop in β forces an increase in I_B to maintain the load. During power up, this translates to large start-up currents. Systems with limited supply current may fail to start up. In battery-powered systems, it means rapid battery discharge when the voltage decays below the minimum required for regulation. The TPS767D3xx quiescent current remains low even when the regulator drops out, eliminating both problems.

The TPS767D3xx family also features a shutdown mode that places the output in the high-impedance state (essentially equal to the feedback-divider resistance) and reduces quiescent current to under 2 μA . If the shutdown feature is not used, $\overline{\text{EN}}$ should be tied to ground. Response to an enable transition is quick; regulated output voltage is typically reestablished in 120 μs .

minimum load requirements

The TPS767D3xx family is stable even at zero load; no minimum load is required for operation.

FB - pin connection (adjustable version only)

The FB pin is an input pin to sense the output voltage and close the loop for the adjustable option. The output voltage is sensed through a resistor divider network as is shown in Figure 27 to close the loop. Normally, this connection should be as short as possible; however, the connection can be made near a critical circuit to improve performance at that point. Internally, FB connects to a high-impedance wide-bandwidth amplifier and noise pickup feeds through to the regulator output. Routing the FB connection to minimize/avoid noise pickup is essential. In fixed output options this pin is a no connect.

external capacitor requirements

An input capacitor is not required; however, a ceramic bypass capacitor (0.047 pF to 0.1 μF) improves load transient response and noise rejection when the TPS767D3xx is located more than a few inches from the power supply. A higher-capacitance electrolytic capacitor may be necessary if large (hundreds of milliamps) load transients with fast rise times are anticipated.

Like all low dropout regulators, the TPS767D3xx requires an output capacitor connected between OUT and GND to stabilize the internal control loop. The minimum recommended capacitance value is 10 μF and the ESR (equivalent series resistance) must be between 50 m Ω and 1.5 Ω . Capacitor values 10 μF or larger are acceptable, provided the ESR is less than 1.5 Ω . Solid tantalum electrolytic, aluminum electrolytic, and multilayer ceramic capacitors are all suitable, provided they meet the requirements described previously.

TPS767D301, TPS767D318, TPS767D325 DUAL-OUTPUT LOW-DROPOUT VOLTAGE REGULATORS

SLVS209B – JULY 1999 – REVISED APRIL 2000

external capacitor requirements (continued)

When necessary to achieve low height requirements along with high output current and/or high ceramic load capacitance, several higher ESR capacitors can be used in parallel to meet the previous guidelines.

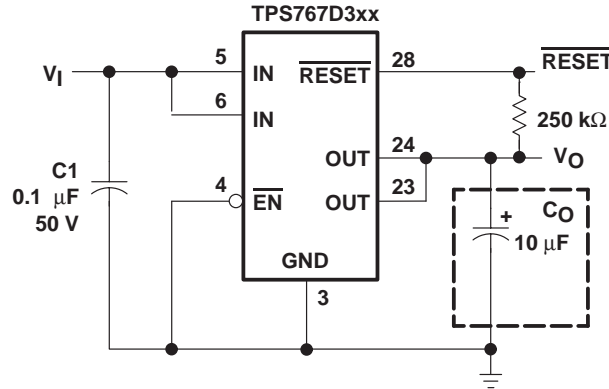

Figure 26. Typical Application Circuit (Fixed Versions) for Single Channel

programming the TPS767D301 adjustable LDO regulator

The output voltage of the TPS767D301 adjustable regulator is programmed using an external resistor divider as shown in Figure 27. The output voltage is calculated using:

$$V_O = V_{ref} \times \left(1 + \frac{R1}{R2}\right) \tag{1}$$

Where:

$$V_{ref} = 1.1834 \text{ V typ (the internal reference voltage)}$$

Resistors R1 and R2 should be chosen for approximately 50-μA divider current. Lower value resistors can be used but offer no inherent advantage and waste more power. Higher values should be avoided as leakage currents at FB increase the output voltage error. The recommended design procedure is to choose R2 = 30.1 kΩ to set the divider current at 50 μA and then calculate R1 using:

$$R1 = \left(\frac{V_O}{V_{ref}} - 1\right) \times R2 \tag{2}$$

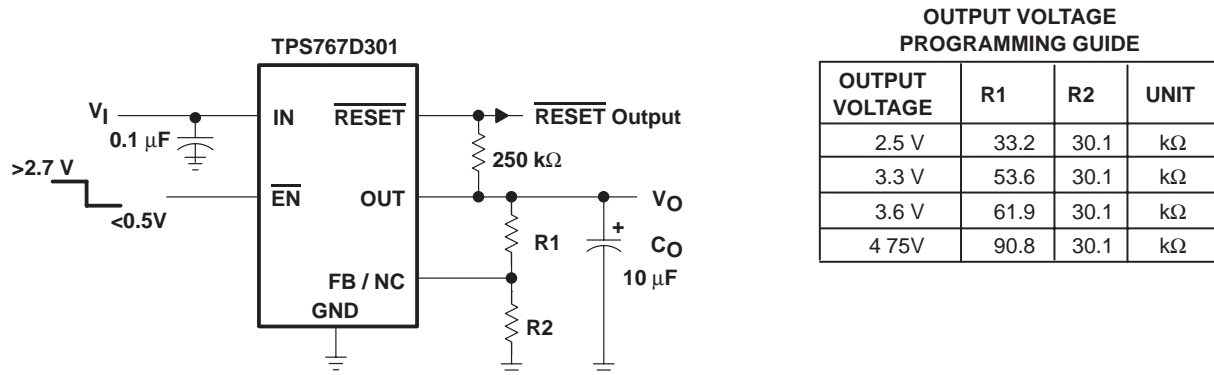

Figure 27. TPS767D301 Adjustable LDO Regulator Programming

TPS767D301, TPS767D318, TPS767D325 DUAL-OUTPUT LOW-DROPOUT VOLTAGE REGULATORS

SLVS209B – JULY 1999 – REVISED APRIL 2000

Reset indicator

The TPS767D3xx features a $\overline{\text{RESET}}$ output that can be used to monitor the status of the regulator. The internal comparator monitors the output voltage: when the output drops to 95% (typical) of its regulated value, the $\overline{\text{RESET}}$ output transistor turns on, taking the signal low. The open-drain output requires a pullup resistor. If not used, it can be left floating. $\overline{\text{RESET}}$ can be used to drive power-on reset circuitry or as a low-battery indicator.

regulator protection

The TPS767D3xx PMOS-pass transistor has a built-in back-gate diode that safely conducts reverse currents when the input voltage drops below the output voltage (e.g., during power down). Current is conducted from the output to the input and is not internally limited. When extended reverse voltage is anticipated, external limiting may be appropriate.

The TPS767D3xx also features internal current limiting and thermal protection. During normal operation, the TPS767D3xx limits output current to approximately 1.7 A. When current limiting engages, the output voltage scales back linearly until the overcurrent condition ends. While current limiting is designed to prevent gross device failure, care should be taken not to exceed the power dissipation ratings of the package. If the temperature of the device exceeds 150°C(typ), thermal-protection circuitry shuts it down. Once the device has cooled below 130°C(typ), regulator operation resumes.

power dissipation and junction temperature

Specified regulator operation is assured to a junction temperature of 125°C; the maximum junction temperature should be restricted to 125°C under normal operating conditions. This restriction limits the power dissipation the regulator can handle in any given application. To ensure the junction temperature is within acceptable limits, calculate the maximum allowable dissipation, $P_{D(\text{max})}$, and the actual dissipation, P_D , which must be less than or equal to $P_{D(\text{max})}$.

The maximum-power-dissipation limit is determined using the following equation:

$$P_{D(\text{max})} = \frac{T_{J\text{max}} - T_A}{R_{\theta JA}}$$

Where:

$T_{J\text{max}}$ is the maximum allowable junction temperature

$R_{\theta JA}$ is the thermal resistance junction-to-ambient for the package, i.e., 27.9°C/W for the 28-terminal PWP with no airflow.

T_A is the ambient temperature.

The regulator dissipation is calculated using:

$$P_D = (V_I - V_O) \times I_O$$

Power dissipation resulting from quiescent current is negligible. Excessive power dissipation will trigger the thermal protection circuit.

TPS767D301, TPS767D318, TPS767D325 DUAL-OUTPUT LOW-DROPOUT VOLTAGE REGULATORS

SLVS209B – JULY 1999 – REVISED APRIL 2000

MECHANICAL DATA

PWP (R-PDSO-G**)

PowerPAD™ PLASTIC SMALL-OUTLINE PACKAGE

20-PIN SHOWN

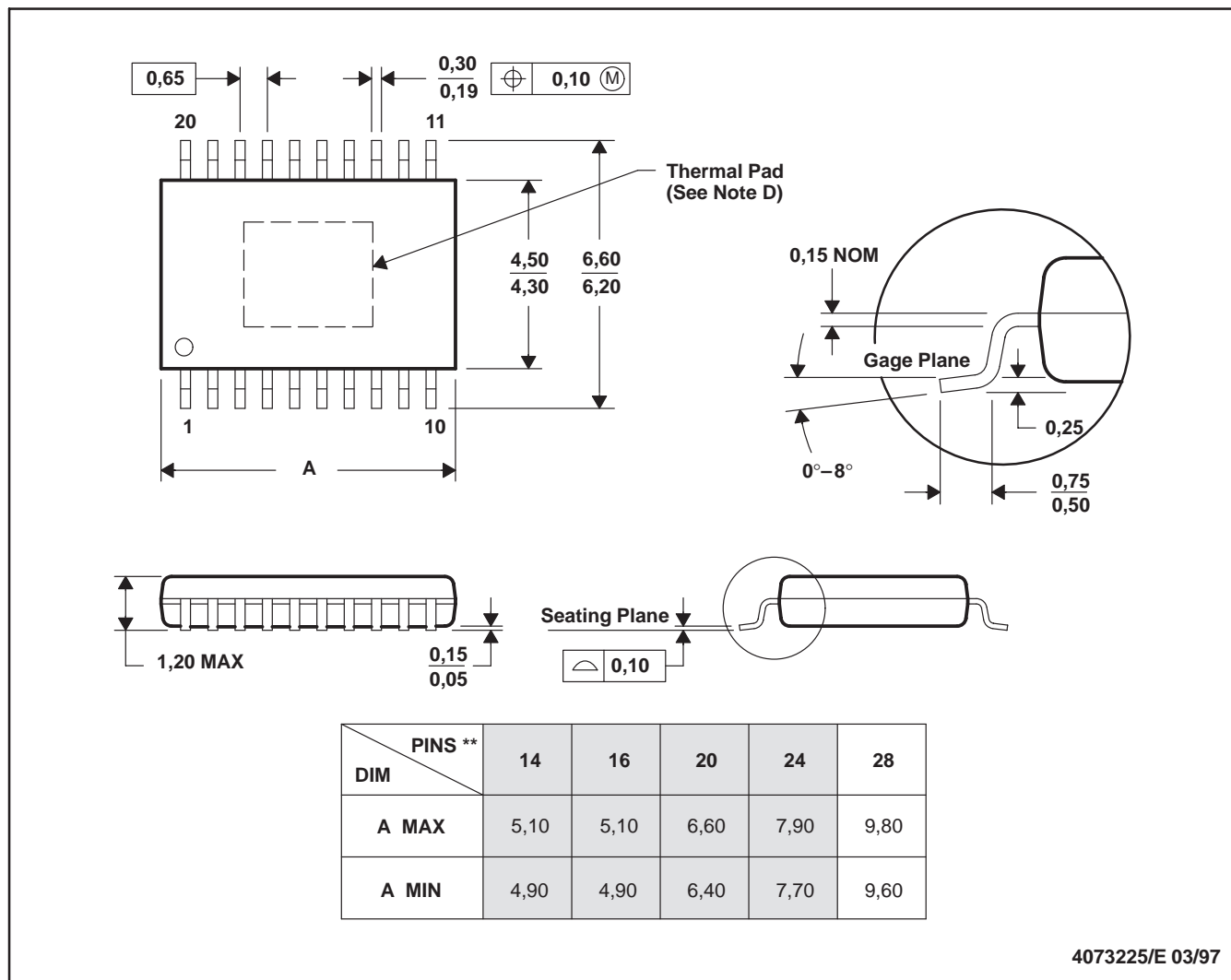

- NOTES: A. All linear dimensions are in millimeters.
 B. This drawing is subject to change without notice.
 C. Body dimensions do not include mold flash or protrusions.
 D. The package thermal performance may be enhanced by bonding the thermal pad to an external thermal plane. This pad is electrically and thermally connected to the backside of the die and possibly selected leads.
 E. Falls within JEDEC MO-153

IMPORTANT NOTICE

Texas Instruments and its subsidiaries (TI) reserve the right to make changes to their products or to discontinue any product or service without notice, and advise customers to obtain the latest version of relevant information to verify, before placing orders, that information being relied on is current and complete. All products are sold subject to the terms and conditions of sale supplied at the time of order acknowledgment, including those pertaining to warranty, patent infringement, and limitation of liability.

TI warrants performance of its semiconductor products to the specifications applicable at the time of sale in accordance with TI's standard warranty. Testing and other quality control techniques are utilized to the extent TI deems necessary to support this warranty. Specific testing of all parameters of each device is not necessarily performed, except those mandated by government requirements.

Customers are responsible for their applications using TI components.

In order to minimize risks associated with the customer's applications, adequate design and operating safeguards must be provided by the customer to minimize inherent or procedural hazards.

TI assumes no liability for applications assistance or customer product design. TI does not warrant or represent that any license, either express or implied, is granted under any patent right, copyright, mask work right, or other intellectual property right of TI covering or relating to any combination, machine, or process in which such semiconductor products or services might be or are used. TI's publication of information regarding any third party's products or services does not constitute TI's approval, warranty or endorsement thereof.