

# SiRFstarIIe/LP Chip Set

## A Low Power GPS Chip Set for Consumer Products

### ARCHITECTURE HIGHLIGHTS

#### Industry Leading GPS Performance

- Builds on high performance SiRFstarIIe
- Architecture supports user task integration
- Signal acquisition using 1920 time/frequency search channels
- SBAS (WAAS and EGNOS), and DGPS support
- Multipath-mitigation hardware
- Cold Start under 45 seconds

#### Low Power

- Under 175 mW at full power
- TricklePower™ mode reduces power to under 60 mW
- Adaptive TricklePower intelligently switches between full and TricklePower.
- Push to fix reduces power by as much as 98%

#### Maximizes GPS Position Availability

- SingleSat™ updates in reduced visibility
- Superior urban canyon performance
- FoliageLock™ for weak signal tracking

### FAMILY HIGHLIGHTS

#### GSP2e/LP - Flexible Digital IC

- Microprocessor throughput measured at up to 40 MIPS
- 8k of cache for improved throughput
- On-chip 1Mb SRAM for GPS navigation
- Integrated high-precision Real-Time Clock
- Extensive GPS receiver peripherals  
2 UARTS, high speed serial bus, battery backed SRAM, >40 GPIO,

#### GRF2i/LP - Low Power RFIC

- On-chip VCO and reference oscillator
- Integrated LNA
- Uses less than 30 mA's of current
- Simplified digital interface

#### GSW2 Modular Software

- Easily integrated into existing systems
- 95% CPU throughput available for user tasks
- Tunable performance in all applications
- Robust development environment
- Compatible with SiRFloc and SiRFxtrac

### SiRFstarII ARCHITECTURE

SiRFstarIIe/LP architecture sets the standard for high volume GPS performance. The SiRFstarIIe/LP still uses 1,920 correlators and 12 channels to provide fast acquisition and re-acquisition times, while keeping peak current to under 65 mA. TricklePower extends battery life even further by reducing average current to under 20mA. Now superior performance features like SingleSat, SnapLock, and FoliageLock are available using less power.

The chipset consists of the GSP2e/LP, a highly integrated digital chip with 40 MIPS of processing power and the GRF2i/LP, a lower power version of the GRF2i integrated front end. The GSW2 software completes the package providing flexible system architecture for stand-alone GPS based products. The SiRFstarIIe/LP also supports SiRF's high sensitivity stand alone software, SiRFxtrac and multi-mode software, SiRFloc. When low power, low cost, and high performance matter SiRFstarIIe/LP is the best solution.



### SiRFstarIIe/LP BLOCK DIAGRAM

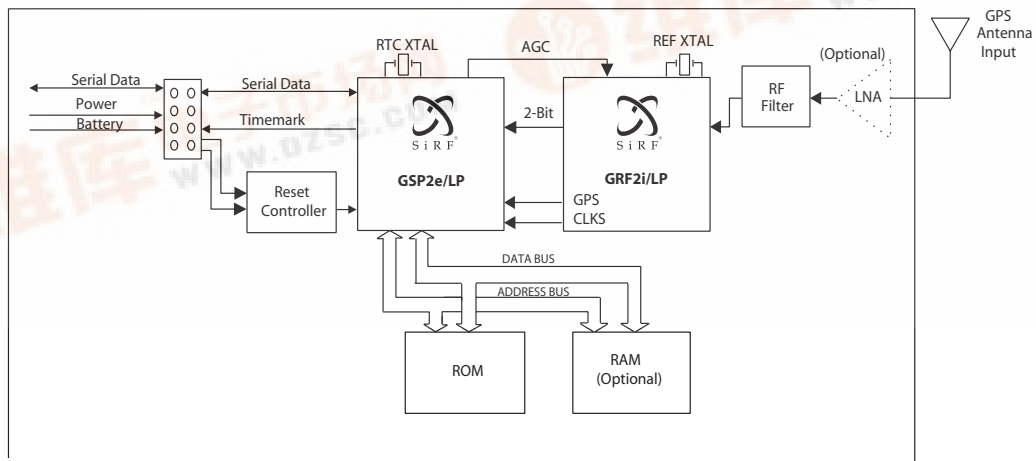

Evaluate

Develop

## TECHNICAL SPECIFICATIONS

<b>Position Accuracy</b>	
Autonomous	<10m
WAAS	<5m
Beacon DGPS	<2.5m
<b>Receiver</b>	
Tracking	L1, CA code
Channels	12
Max. Update Rate	10Hz
Sensitivity	-172dBW
Max. Altitude	<60,000 ft
Max. Velocity	<1,000 knots
Protocol Support	NMEA, SiRF Binary
<b>Acquisition</b>	
Reacquisition Time	100msec
SnapStart	<3sec
Hot Start	<8sec
Warm Start	<38sec
Cold Start	<45sec
<b>Power</b>	
Full Power (S2AM Module)	<175mW
TricklePower (1Hz)	<60mW
Voltage	2.7-3.3V (5V I/O capable)
<b>Processor</b>	
Processor Type	ARM7/TDMI
Processor Speeds	6MHz, 12.5MHz, 25MHz, 49MHz
Data Bus	16 Bit or 32 Bit
Ports	>40 GPIO

Specifications above are for GSW2

## WORLDWIDE SALES OFFICES

**SiRF California**  
+1 (408) 467-0410  
sales@sirf.com

**SiRF Texas  
Central U.S.**  
+1 (972) 239-6988  
jdaniels@sirf.com

**SiRF Taiwan Kingdom**  
+44 1344 668390  
aellis@sirf.com

**SiRF France**  
+33 3 82 86 04 15  
rocky@sirf.com

**SiRF Europe**  
+49 81 529932-90  
peterz@sirf.com

**SiRF Taiwan**  
+886 2 2723 7853  
tomlin@sirf.com

## APPLICATIONS

The SiRFstarIIe/LP is a flexible low-power GPS chip set that integrates into a postage-stamp sized receiver. It works well where GPS is the main function such as handheld GPS, marine GPS, or personal locators or where the design calls for stand-alone GPS functionality such as GPS integrated into the batteryback of a cell phone or in an add on compact flash card. The excess processing power can be used for user tasks such as running an LCD or controlling an Automatic Vehicle Location module.

## CHIP ORDERING CONFIGURATION

### RF CHIP PACKAGES

Chip Name	Chip PN	Package
SiRFstarII GRF2i/LP	GRF2i/LP-0210	LQFP, 48 pin
SiRFstarII GRF2i/LP (QFN)	GRF2i/LP-0214	(LPCC), 32 pin

### DIGITAL CHIP PACKAGES

Chip Name	Chip PN	Package
SiRFstarII GSP2e/LP	GSP2E/LP-7450	TQFP, 16-bit, 100 pin
SiRFstarII GSP2e/LP	GSP2E/LP-7451	BGA, 16-bit, 144 pin
SiRFstarII GSP2e/LP	GSP2E/LP-7460	LQFP, 32-bit, 144 pin

### ADDITIONAL SOFTWARE OPTIONS

SiRFxtrac (High Sensitivity stand alone software)  
SiRFLoc (High Sensitivity multimode software)

For more information, contact your SiRF representative, call our sales force on +1 (408) 467-0410, or visit us at [www.sirf.com](http://www.sirf.com).

### Mobile Compute



Consumer and marine

### Automobile



Wireless