

XC6210 Series



High Current, High Speed LDO Regulators

- ◆ CMOS
- ◆ Low Power Consumption : 35 μ A (TYP.)
- ◆ Maximum Output Current : More than 700mA (800mA limit, TYP.)
- ◆ Dropout Voltage : 50mV @ 100mA : 100mV @ 200mA
- ◆ Operating Voltage Range : 1.5V ~ 6.0V
- ◆ Output Voltage Range : 0.8V ~ 5.0V
- ◆ Low ESR Capacitor Compatible

GENERAL DESCRIPTION

The XC6210 series are precise, low noise, high current, positive voltage low dropout regulators. They are fabricated using Torex's CMOS process.

The series features a voltage reference, an error amplifier, a current limiter, and a phase compensation circuit plus a driver transistor.

With a low ON resistance driver transistor built into, batteries can be used until input-output voltage differential is minimal and can accordingly be used for a longer time.

The series is also compatible with low ESR ceramic capacitors which give added output stability.

The output voltage of the LDO is selectable in 50mV increments within the range of 0.8V to 5.0V.

The current limiter's foldback circuit also operates as the output current limiter and the output pin protection.

The IC's internal regulator circuit can be placed in stand-by mode via the CE function. In the stand-by mode, power consumption is greatly reduced.

APPLICATIONS

- CD-ROMs, CD-R / RW drive
- DVD drive
- HDD drive
- Cameras, Video recorders
- Portable AV equipment
- Battery powered equipment

FEATURES

- Maximum Output Current** : More than 700mA (800mA limit, TYP.) (1.6V \leq V_{OUT(T)} \leq 5.0V)
- Dropout Voltage** : 50mV@I_{OUT}=100mA
- Operating Voltage Range** : 1.5V ~ 6.0V
- Output Voltage Range** : 0.8V ~ 5.0V (50mV increments)
- Highly Accurate** : \pm 2% (The setting voltage accuracy)
- Low Power Consumption** : 35 μ A (TYP.)
- High Ripple Rejection** : 60dB @1kHz
- Operational Ambient Temperature** : - 40 $^{\circ}$ C ~ 85 $^{\circ}$ C
- Ultra Small Packages** : SOT-25 (SOT-23-5) SOT-89-5 USP-6B

TYPICAL APPLICATION CIRCUIT

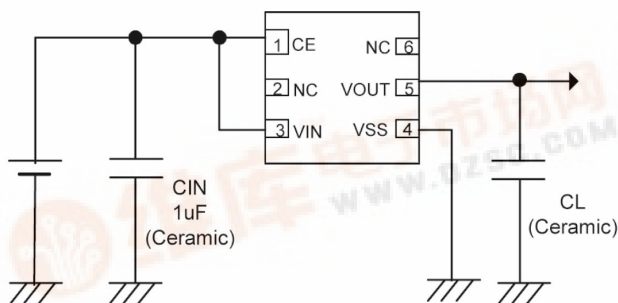

TYPICAL PERFORMANCE CHARACTERISTICS

- Dropout Voltage vs. Output Current

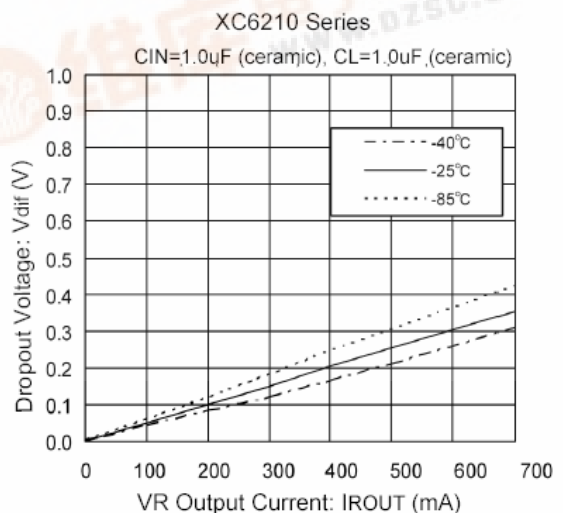

XC6210 Series

PIN CONFIGURATION

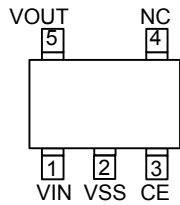

SOT-25 (TOP VIEW)

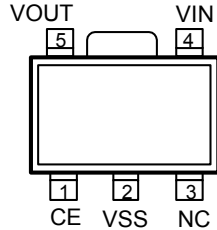

SOT-89-5 (TOP VIEW)

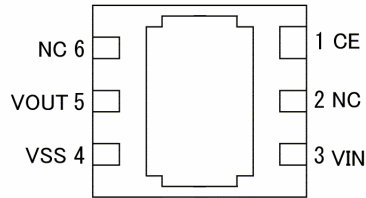

USP-6B (BOTTOM VIEW)

*The dissipation pad for the USP-6B package should be solder-plated in recommended mount pattern and metal masking so as to enhance mounting strength and heat release. If the pad needs to be connected to other pins, it should be connected to the Vss pins.

PIN ASSIGNMENT

PIN NUMBER			PIN NAME	FUNCTION
SOT-25	SOT-89-5	USP-6B		
3	1	1	CE	ON/OFF Control
1	4	3	VIN	Power Input
2	2	4	VSS	Ground
5	5	5	VOUT	Output
4	3	2, 6	NC	No Connection

PRODUCT CLASSIFICATION

Selection Guide

CE Input Logic, Internal Pull-Up / Down Resistor

SERIES	CE INPUT LOGIC
XC6210A	High Active with Pull-Down Resistor
XC6210B	High Active with No Pull-Down Resistor
XC6210C	Low Active with Pull-Up Resistor
XC6210D	Low Active with No Pull-Up Resistor

Ordering Information

XC6210 ①②③④⑤⑥

DESIGNATOR	DESCRIPTION	SYMBOL	DESCRIPTION
①	CE Pin Functions	A	: High Active with pull-down resistor
		B	: High Active with no pull-down resistor
		C	: Low Active with pull-up resistor
		D	: Low Active with no pull-up resistor
② ③	Output Voltage	08~50	: ex.) 3.0V → ②=3, ③=0
④	Output Voltage Accuracy	2	: 100mV increments, ±2% (VOUT≤1.5V→less than ±30mV) ex.) 2.80V→②=2, ③=8, ④=2
		A	: 50mV increments, ±2% (VOUT≤1.5V→less than ±30mV) ex.) 2.85V→②=2, ③=8, ④=A
⑤	Packages	M	: SOT-25 (SOT-23-5)
		P	: SOT-89-5
		D	: USP-6B
⑥	Device Orientation	R	: Embossed tape, standard feed
		L	: Embossed tape, reverse feed

PACKAGING INFORMATION

● SOT-25 (SOT-23-5)

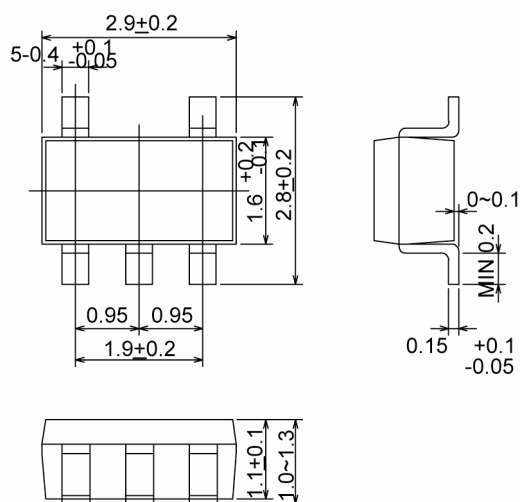

● SOT-89-5

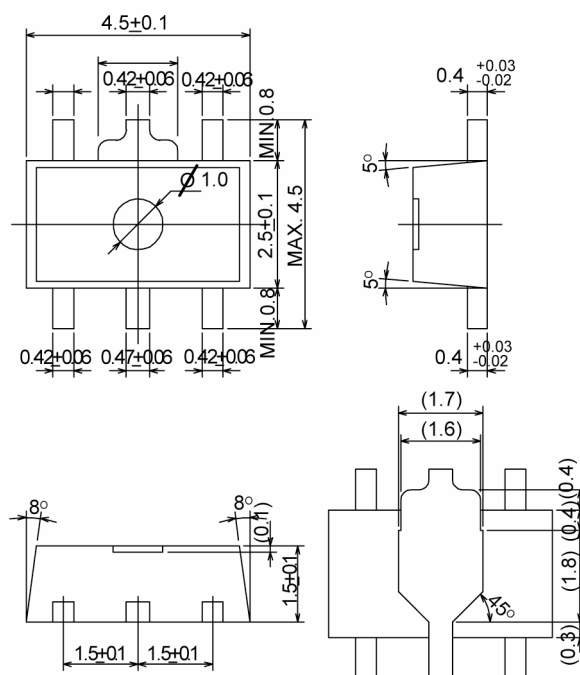

● USP-6B

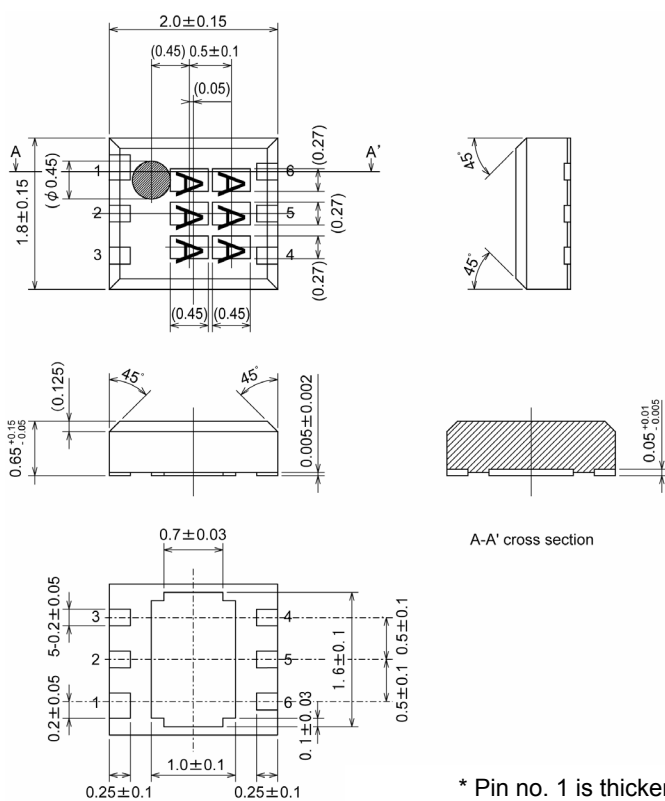

A-A cross section

* Pin no. 1 is thicker than other pins.



XC6210 Series

MARKING RULE

● SOT-25

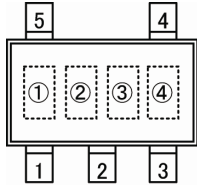

SOT-25
(TOP VIEW)

● SOT-89-5

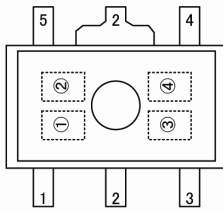

SOT-89-5
(TOP VIEW)

① Represents product series

MARK	PRODUCT SERIES
0	XC6210xxxxxx

② Represents CE function

MARK				PRODUCT SERIES
VOLTAGE= 0.1~3.0V	VOLTAGE= 3.1~6.0V	VOLTAGE= 0.15~3.05V	VOLTAGE= 3.15~6.05V	
V	A	E	L	XC6210Axxxxx
X	B	F	M	XC6210Bxxxxx
Y	C	H	N	XC6210Cxxxxx
Z	D	K	P	XC6210Dxxxxx

③ Represents output voltage

MARK	OUTPUT VOLTAGE (V)				MARK	OUTPUT VOLTAGE (V)			
	-	3.1	-	3.15		1.6	4.6	1.65	4.65
0	-	3.1	-	3.15	F	1.6	4.6	1.65	4.65
1	-	3.2	-	3.25	H	1.7	4.7	1.75	4.75
2	-	3.3	-	3.35	K	1.8	4.8	1.85	4.85
3	-	3.4	-	3.45	L	1.9	4.9	1.95	4.95
4	-	3.5	-	3.55	M	2.0	5.0	2.05	-
5	-	3.6	-	3.65	N	2.1	-	2.15	-
6	-	3.7	-	3.75	P	2.2	-	2.25	-
7	0.8	3.8	-	3.85	R	2.3	-	2.35	-
8	0.9	3.9	0.85	3.95	S	2.4	-	2.45	-
9	1.0	4.0	0.95	4.05	T	2.5	-	2.55	-
A	1.1	4.1	1.15	4.15	U	2.6	-	2.65	-
B	1.2	4.2	1.25	4.25	V	2.7	-	2.75	-
C	1.3	4.3	1.35	4.35	X	2.8	-	2.85	-
D	1.4	4.4	1.45	4.45	Y	2.9	-	2.95	-
E	1.5	4.5	1.55	4.55	Z	3.0	-	3.05	-

④ Represents production lot number

0 to 9, A to Z reverse character 0 to 9, A to Z repeated (G, I, J, O, Q, W excepted)



MARKING RULE (Continued)

● USP-6B

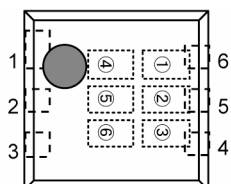

USP-6B
(TOP VIEW)

①② Represents product series

MARK		PRODUCT SERIES
①	②	
1	0	XC6210xxxxxx

③ Represents CE Function

MARK	TYPE	PRODUCT SERIES
A	High Active With Pull-Down Resistor	XC6210AxxxDx
B	High Active With No Pull-Down Resistor	XC6210AxxxDx
C	Low Active With Pull-Up Resistor	XC6210AxxxDx
D	Low Active With No Pull-Up Resistor	XC6210AxxxDx
S	Custom	XC6210AxxxDx

④ Represents the integer number of output voltage

MARK	VOLTAGE (V)	PRODUCT SERIES
3	3.3	XC6210x3xxDx
5	5.0	XC6210x5xxDx

⑤ Represents the decimal point of output voltage

MARK	VOLTAGE (V)	PRODUCT SERIES	MARK	VOLTAGE (V)	PRODUCT SERIES
0	x.0	XC6210xx02Dx	A	x.05	XC6210xx0ADx
1	x.1	XC6210xx12Dx	B	x.15	XC6210xx1ADx
2	x.2	XC6210xx22Dx	C	x.25	XC6210xx2ADx
3	x.3	XC6210xx32Dx	D	x.35	XC6210xx3ADx
4	x.4	XC6210xx42Dx	E	x.45	XC6210xx4ADx
5	x.5	XC6210xx52Dx	F	x.55	XC6210xx5ADx
6	x.6	XC6210xx62Dx	H	x.65	XC6210xx6ADx
7	x.7	XC6210xx72Dx	K	x.75	XC6210xx7ADx
8	x.8	XC6210xx82Dx	L	x.85	XC6210xx8ADx
9	x.9	XC6210xx92Dx	M	x.95	XC6210xx9ADx

⑥ Represents production lot number

0 to 9, A to Z repeated (G, I, J, O, Q, W, excepted)

Note: No character inversion used.



XC6210 Series

■ BLOCK DIAGRAM

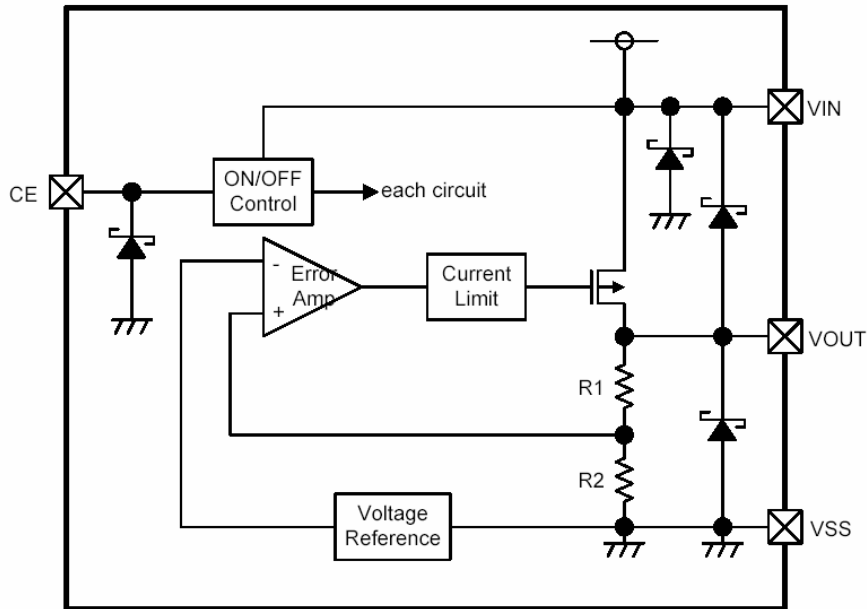

■ ABSOLUTE MAXIMUM RATINGS

Ta=25°C

PARAMETER	SYMBOL	RATINGS	UNITS
Input Voltage	V _{IN}	6.5	V
Output Current *	I _{OUT}	900	mA
Output Voltage	V _{OUT}	V _{SS} - 0.3 ~ V _{IN} + 0.3	V
CE Pin Voltage	V _{CE}	V _{SS} - 0.3 ~ 6.5	V
Power Dissipation	SOT-25	250	mW
	SOT-89-5	500	
	USP-6B	100	
Operating Temperature Range	T _{opr}	- 40 ~ + 85	°C
Storage Temperature Range	T _{stg}	- 55 ~ + 125	°C

* I_{OUT}=P_d / (V_{IN} - V_{OUT})



ELECTRICAL CHARACTERISTICS

●XC6210 series

Ta=25°C

PARAMETER	SYMBOL	CONDITIONS	MIN.	TYP.	MAX.	UNITS	CIRCUIT
Output Voltage (*2), (*3)	VOUT(E)	VIN=VOUT(T)+1.0V, IOUT=30mA VCE=ON (VIN or VSS)	x 0.98	VOUT(T)	x 1.02	V	①
		VOUT(T)≤1.5V, IOUT=30mA VCE=ON (VIN or VSS)	(-30mV)	VOUT(T)	(+30mV)		
Maximum Output Current [VOUT(E)>1.6V]	IOUTMAX	VIN=VOUT(T)+1.0V, VCE=ON (VIN or VSS)	700	-	-	mA	①
Maximum Output Current [VOUT(E)≤1.5V]	IOUTMAX	VIN=VOUT(T)+1.0V, VCE=ON (VIN or VSS)	500	-	-		
Load Regulation	ΔVOUT	1mA≤IOUT≤100mA, VCE=ON(VIN or VSS)	-	15	60	mV	①
Dropout Voltage (*4)	Vdif1	IROUT=30mA, VCE=ON (VIN or VSS)	E-1			mV	①
	Vdif2	IROUT=100mA, VCE=ON (VIN or VSS)	E-2				
Supply Current (A type)	IDD	VIN=VCE=VOUT(T)+1.0V	E-3			μA	②
Supply Current (B type)		VIN=VCE=VOUT(T)+1.0V	-	35	55		
Supply Current (C type)		VIN=VOUT(T)+1.0V, VCE=VSS	E-3				
Supply Current (D type)		VIN=VOUT(T)+1.0V, VCE=VSS	-	35	55		
Line Regulation	$\frac{\Delta V_{OUT}}{\Delta V_{IN} \cdot V_{OUT}}$	VOUT(T)+1.0V≤VIN≤6.0V When VOUT(T)≥4.5V, 5.5V≤VIN≤6.0V VCE=ON (VIN or VSS), IOUT=30mA	-	0.01	0.20	% / V	①
Input Voltage	VIN	-	1.5	-	6.0	V	-
Output Voltage Temperature Characteristics	$\frac{\Delta V_{OUT}}{\Delta T_{opr} \cdot V_{OUT}}$	IOUT=30mA, VCE=ON (VIN or VSS) -40°C≤Topr≤85°C	-	±100	-	ppm/ °C	①
Ripple Rejection Rate	PSRR	VIN=[VOUT(T)+1.0]VDC+0.5Vp-pAC When VOUT(T)≥4.75V → VIN=5.75VDC+0.5Vp-pAC VCE=ON (VIN or VSS), IOUT=30mA, f=1kHz	-	60	-	dB	③
Current Limiter [VOUT(E)>1.6V]	Ilim	VIN=VOUT(T)+1.0V, VCE=ON(VIN or VSS)	700	800	-	mA	①
Current Limiter [VOUT(E)≤1.5V]	Ilim	VIN=VOUT(T)+1.0V, VCE=ON(VIN or VSS)	-	800	-		
Short-Circuit Current	Ishort	VIN=VOUT(T)+1.0V, VCE=ON(VIN or VSS)	-	50	-	mA	①
CE "High" Level Voltage	VCEH	-	1.3	-	6.0	V	①
CE "Low" Level Voltage	VCEL	-	-	-	0.25		
CE "High" Level Current (A type)	ICEH	VIN=VCE=VOUT(T)+1.0V	E-4	-	E-4	μA	①
CE "High" Level Current (B / C / D type)			- 0.10	-	0.10		
CE "Low" Level Current (C type)	ICEL	VIN=VOUT(T)+1.0V, VCE=VSS	E-5	-	E-5	μA	①
CE "Low" Level Current (A / B / D type)			- 0.10	-	0.10		

NOTE:

*1: Unless otherwise stated, VIN=VOUT(T)+1.0V

*2: VOUT(T)=Specified output voltage

*3: VOUT(E)=Effective output voltage

(i.e. the output voltage when "VOUT(T)+1.0V" is provided while maintaining a certain IOUT value).

*4: Vdif={VIN1⁽⁶⁾-VOUT1⁽⁵⁾}

*5: A voltage equal to 98% of the output voltage whenever a stabilized VOUT1=IOUT{VOUT(T)+1.0V} is input.

*6: VIN1= the input voltage when VOUT1, which appears as input voltage is gradually decreased.

*7: VOUT(T)≤1.50V MIN. : VOUT(T) - 30mV, MAX. : VOUT(T) +30mV

*8: CE conditions: XC6210A / B type: ON=VIN, OFF=VSS

XC6210C / D type: ON=VSS, OFF=VIN



XC6210 Series

■ VOLTAGE CHART

● Dropout Voltage, Supply Current, CE "H / L" Level Current Chart

Ta=25°C

SETTING OUTPUT VOLTAGE	OUTPUT VOLTAGE (Accuracy: 2%)		E-1		E-2		E-3		E-4		E-5				
			DROPOUT VOLTAGE 1 (I _{OUT} =30mA)		DROPOUT VOLTAGE 2 (I _{OUT} =100mA)		SUPPLY CURRENT		CE "H" LEVEL CURRENT		CE "L" LEVEL CURRENT				
(V)	(V)		(mV)		(mV)		(μA)		(μA)		(μA)				
V _{OUT(T)}	V _{OUT}		V _{dif1}		V _{dif2}		I _{DD}		I _{CEH}		I _{CEL}				
	MIN.	MAX.	TYP.	MAX.	TYP.	MAX.	TYP.	MAX.	MIN.	MAX.	MIN.	MAX.			
0.80	0.770	0.830	100.0	700.0	250.0	800.0	38.0	60.0	1.50	5.00	-5.00	-1.50			
0.85	0.820	0.880		600.0									700.0		
0.90	0.870	0.930		50.0									500.0	150.0	600.0
0.95	0.920	0.980											400.0		
1.00	0.970	1.030	30.0	300.0	100.0	400.0	38.5	61.5	2.00	6.50	-6.50	-2.00			
1.05	1.020	1.080		200.0									300.0		
1.10	1.070	1.130		100.0									100.0	250.0	
1.15	1.120	1.180											100.0		250.0
1.20	1.170	1.230	27.0	41.0	90.0	135.0	39.0	63.0	2.50	8.00	-8.00	-2.50			
1.25	1.220	1.280													
1.30	1.270	1.330													
1.35	1.320	1.380													
1.40	1.370	1.430													
1.45	1.420	1.480													
1.50	1.470	1.530													
1.55	1.519	1.581													
1.60	1.568	1.632													
1.65	1.617	1.683													
1.70	1.666	1.734	25.0	37.0	80.0	120.0	39.5	64.5	3.00	9.50	-9.50	-3.00			
1.75	1.715	1.785													
1.80	1.764	1.836													
1.85	1.813	1.887													
1.90	1.862	1.938													
1.95	1.911	1.989													
2.00	1.960	2.040													
2.05	2.009	2.091													
2.10	2.058	2.142													
2.15	2.107	2.193													
2.20	2.156	2.244	18.0	28.0	60.0	90.0	40.0	66.0	3.50	11.00	-11.00	-3.50			
2.25	2.205	2.295													
2.30	2.254	2.346													
2.35	2.303	2.397													
2.40	2.352	2.448													
2.45	2.401	2.499													
2.50	2.450	2.550													
2.55	2.499	2.601													
2.60	2.548	2.652													
2.65	2.597	2.703													
2.70	2.646	2.754													
2.75	2.695	2.805													
2.80	2.744	2.856													
2.85	2.793	2.907													
2.90	2.842	2.958													
2.95	2.891	3.009													



VOLTAGE CHART (Continued)

● Dropout Voltage, Supply Current, CE "H / L" Level Current Chart

Ta=25°C

SETTING OUTPUT VOLTAGE	OUTPUT VOLTAGE (Accuracy: 2%)		E-1		E-2		E-3		E-4		E-5	
			DROPOUT VOLTAGE 1 (I _{OUT} =30mA)		DROPOUT VOLTAGE 2 (I _{OUT} =100mA)		SUPPLY CURRENT		CE "H" LEVEL CURRENT		CE "L" LEVEL CURRENT	
(V)	(V)		(mV)		(mV)		(μA)		(μA)		(μA)	
V _{OUT(T)}	V _{OUT}		V _{dif1}		V _{dif2}		I _{DD}		I _{CEH}		I _{CEL}	
	MIN.	MAX.	TYP.	MAX.	TYP.	MAX.	TYP.	MAX.	MIN.	MAX.	MIN.	MAX.
3.00	2.940	3.060	15.0	23.0	50.0	75.0	40.5	67.5	4.00	12.50	-12.50	-4.00
3.05	2.989	3.111										
3.10	3.038	3.162										
3.15	3.087	3.213										
3.20	3.136	3.264										
3.25	3.185	3.315										
3.30	3.234	3.366										
3.35	3.283	3.417										
3.40	3.332	3.468										
3.45	3.381	3.519										
3.50	3.430	3.570	15	23	50	75	41.0	69.0	4.40	14.00	-14.00	-4.40
3.55	3.479	3.621										
3.60	3.528	3.672										
3.65	3.577	3.723										
3.70	3.626	3.774										
3.75	3.675	3.825										
3.80	3.724	3.876										
3.85	3.773	3.927										
3.90	3.822	3.978										
3.95	3.871	4.029										
4.00	3.920	4.080	15.0	23.0	50.0	75.0	41.5	70.5	4.85	15.50	-15.50	-4.85
4.05	3.969	4.131										
4.10	4.018	4.182										
4.15	4.067	4.233										
4.20	4.116	4.284										
4.25	4.165	4.335										
4.30	4.214	4.386										
4.30	4.214	4.386										
4.40	4.312	4.488										
4.45	4.361	4.539										
4.50	4.410	4.590	42.0	72.0	5.30	17.00	-17.00	-5.30				
4.55	4.459	4.641										
4.60	4.508	4.692										
4.65	4.557	4.743										
4.70	4.606	4.794										
4.75	4.655	4.845										
4.80	4.704	4.896										
4.85	4.753	4.947										
4.90	4.802	4.998										
4.95	4.851	5.049										
5.00	4.900	5.100										



XC6210 Series

TEST CIRCUITS

● Circuit ①

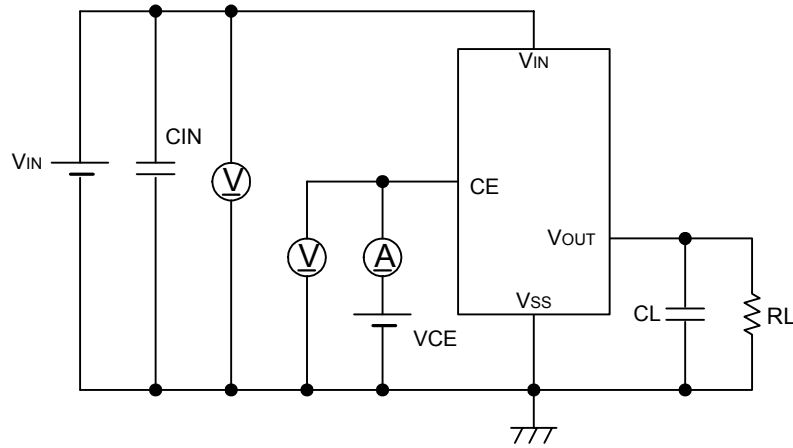

● Circuit ②

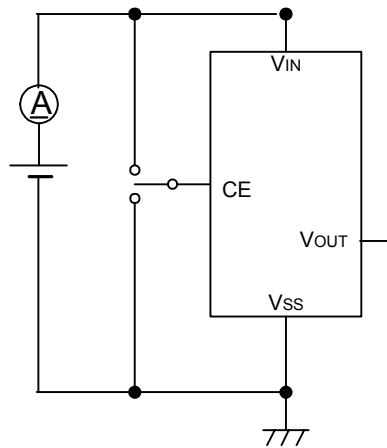

● Circuit ③

$V_{IN} = \{V_{OUT} + 1.0V\}V_{DC} + 0.5V_{p-pAC}$
 $V_{OUT} \geq 4.75V$
 $V_{IN} = 5.75V_{DC} + 0.5V_{p-pAC}$

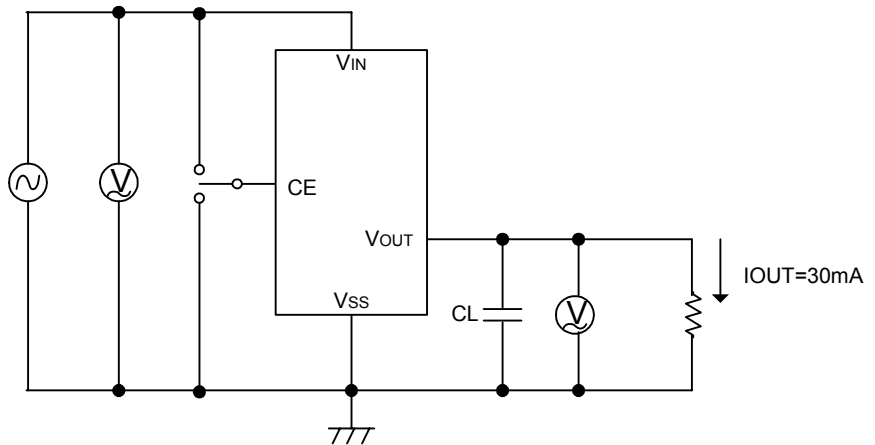

● Output Capacitor Corresponding Chart

VR OUTPUT VOLTAGE	0.8V~1.45V	1.5V ~ 1.75V	1.8V ~ 5.0V
CL	More than 6.8 μ F	More than 4.7 μ F	More than 1.0 μ F



■ OPERATIONAL EXPLANATION

<Output Voltage Regulator Control>

The voltage, divided by resistors R1 & R2, which are connected to the V_{OUT} pin is compared with the internal reference voltage by the error amplifier. The P-channel MOSFET, which is connected to the V_{OUT} pin, is then driven by the subsequent output signal. The output voltage at the V_{OUT} pin is controlled & stabilized by negative feedback. The constant current limit circuit and short circuit protection operate in relation to the level of output current.

<Low ESR Capacitor>

With the XC6210 series regulator, a stable output voltage is achievable even if low ESR capacitors are used, as a phase compensation circuit is built into the regulator. In order to ensure the effectiveness of the phase compensation, we suggest that an output capacitor (C_L) be connected as close as possible, between the output pin (V_{OUT}) and the V_{SS} pin. Please use an output capacitor (C_L) with a capacitance, based on the chart below. We also suggest an input capacitor (C_{IN}) of 1μF: this should be connected between V_{IN} and V_{SS} in order to stabilize input power source.

Output Capacitor Corresponding Chart

V _{OUT}	0.8V ~ 1.45V	1.5V ~ 1.75V	1.8V ~ 5.0V
C _L	More than 6.8μF	More than 4.7μF	More than 1.0μF

<Current Limiter, Short-Circuit Protection>

The XC6210 series regulator offers a combination of current limit and short circuit protection by means of a built-in fixed current limiter circuit and a foldback circuit. When the load current reaches the current limit level, the fixed current limiter circuit operates and output voltage drops. As a result of this drop in output voltage, the foldback circuit operates, the output voltage drops further and output current decreases. When the output pin is shorted, a current of about 50mA flows.

<CE Pin>

The IC's internal regulator circuitry can be shut down via the signal from the CE pin with the XC6210 series. In shutdown mode, output at the V_{OUT} pin will be pulled down to the V_{SS} level via R1 & R2. Options are available for the CE pin logic (See the product classification). Note that as the XC6210B types are 'High Active / No Pull-Down', operations will become unstable with the CE pin open. Although the CE pin is equal to an inverter input with CMOS hysteresis, with either the pull-up or pull-down options, the CE pin input current will increase when the IC is in operation. We suggest that you use this IC with either a V_{IN} voltage or a V_{SS} voltage input at the CE pin. If this IC is used with the correct specifications for the CE pin, the IC will operate normally. However, supply current may increase as a result of through current in the IC's internal circuitry if a voltage other than V_{IN} or V_{SS} is applied.

■ NOTES ON USE

1. Please use this IC within the stated absolute maximum ratings. The IC is liable to malfunction should the ratings be exceeded.
2. Where wiring impedance is high, operations may become unstable due to noise and/or phase lag depending on output current. Please strengthen V_{IN} and V_{SS} wiring in particular.
3. Please wire the input capacitor (C_{IN}) and the output capacitor (C_L) as close to the IC as possible. Should rapid input fluctuation or load fluctuation occur, please increase the capacitor value such as C_{IN} or C_L to stabilize the operation.



XC6210 Series

TYPICAL PERFORMANCE CHARACTERISTICS

(1) Output Voltage vs. Output Current

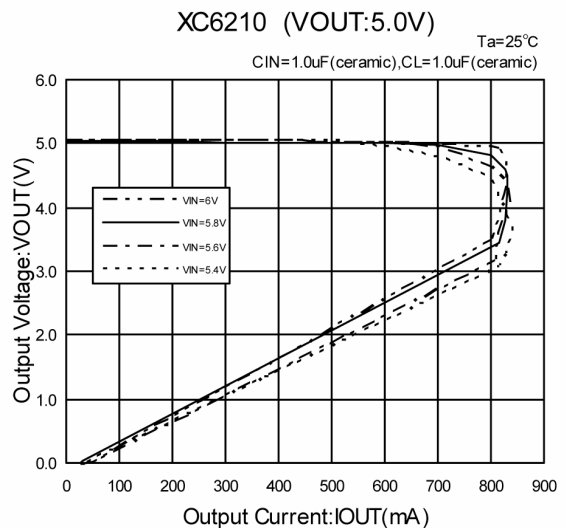
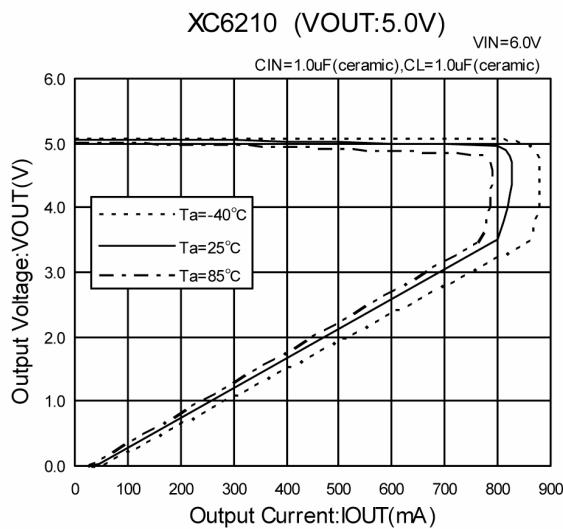
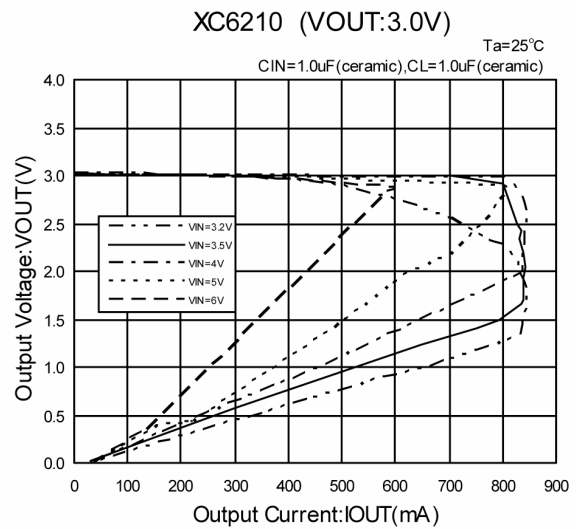
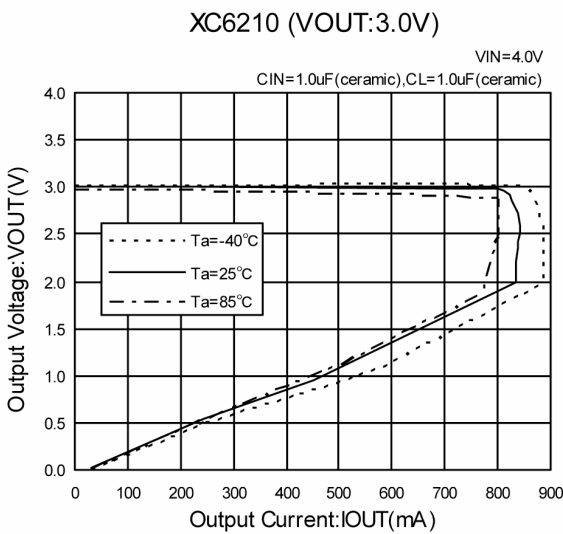
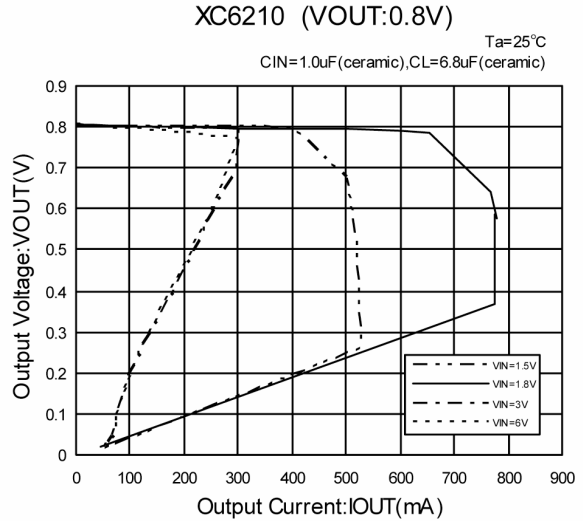
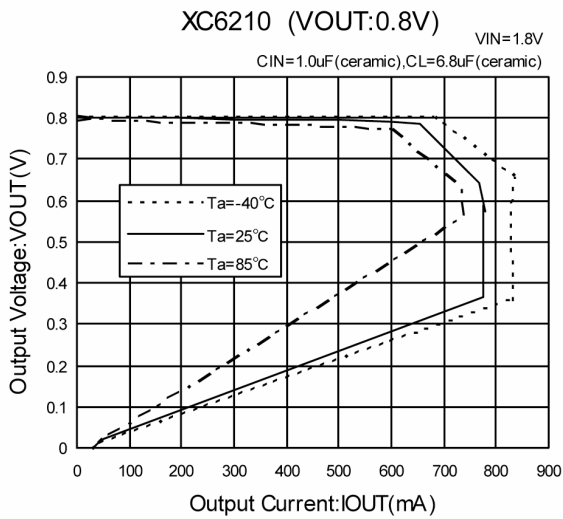

TYPICAL PERFORMANCE CHARACTERISTICS (Continued)

(2) Output Voltage vs. Input Voltage

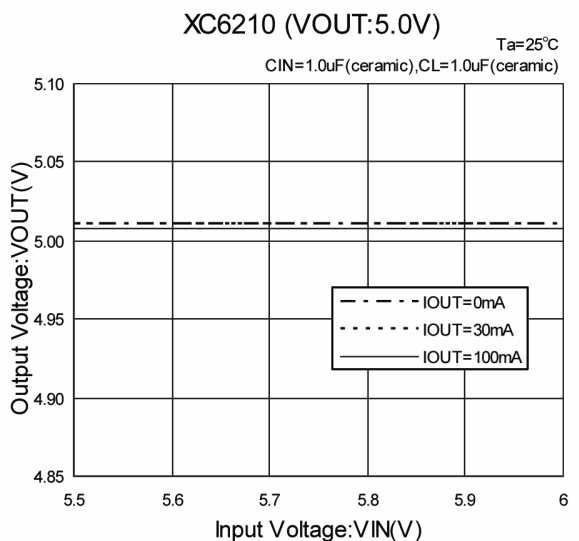
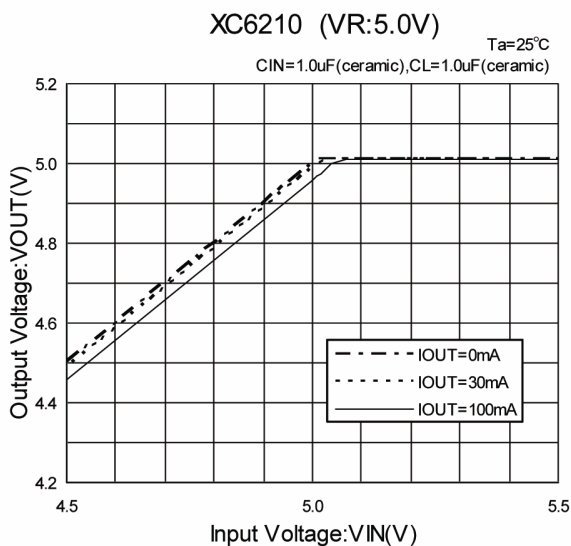
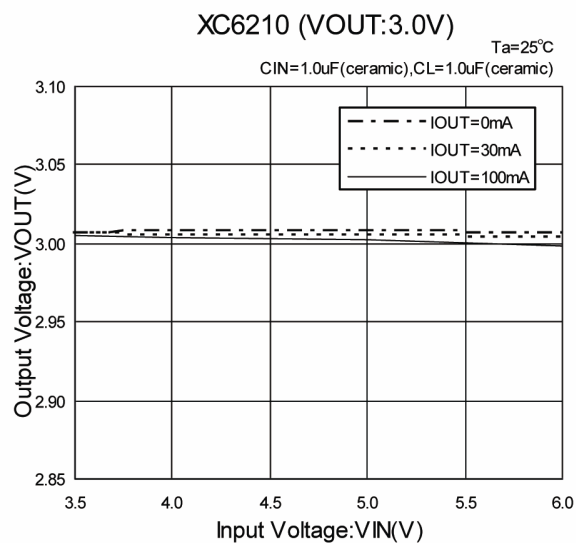
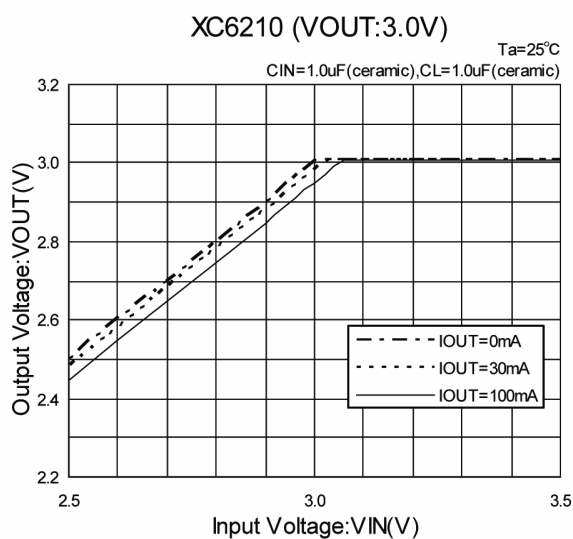
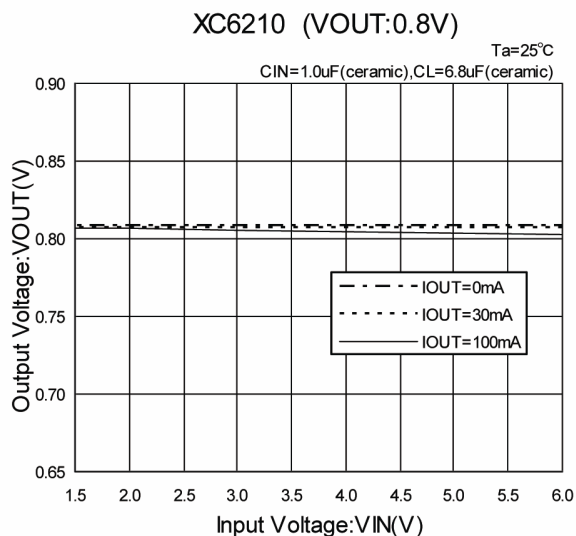
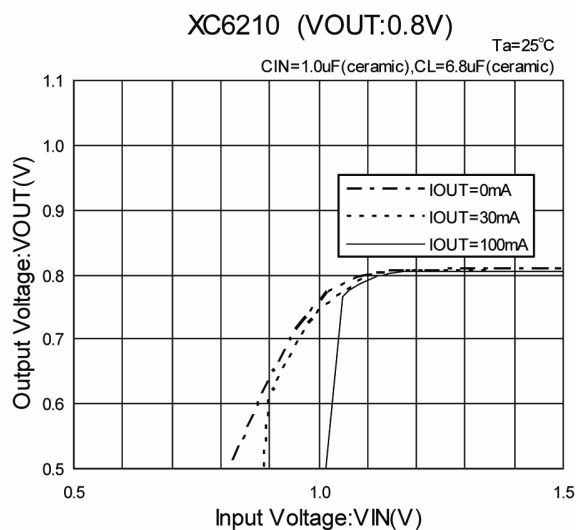

XC6210 Series

TYPICAL PERFORMANCE CHARACTERISTICS (Continued)

(3) Dropout Voltage vs. Output Current

XC6210 (VOUT:0.8V)

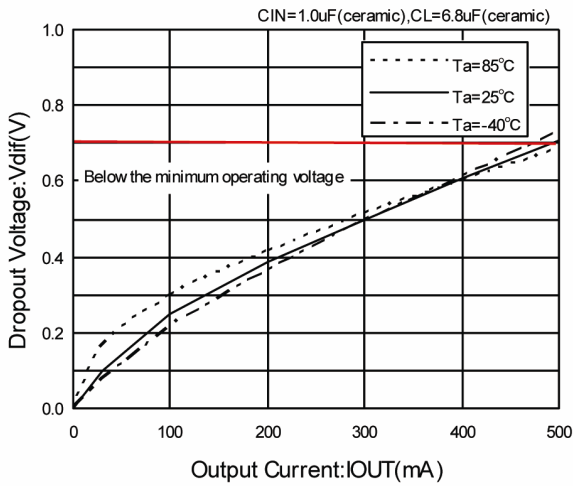

XC6210 (VOUT:1.2V)

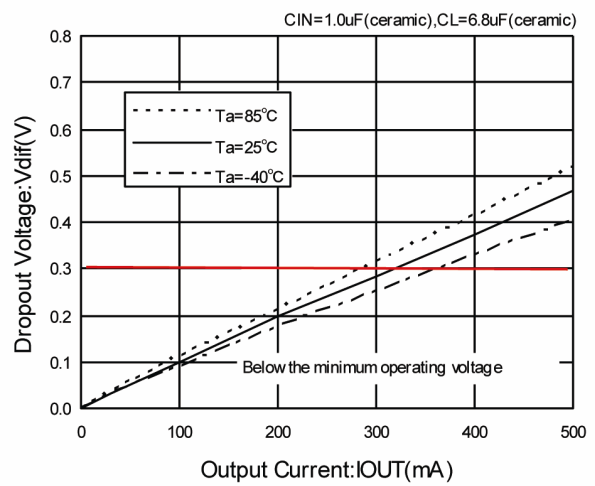

XC6210 (VOUT:1.5V)

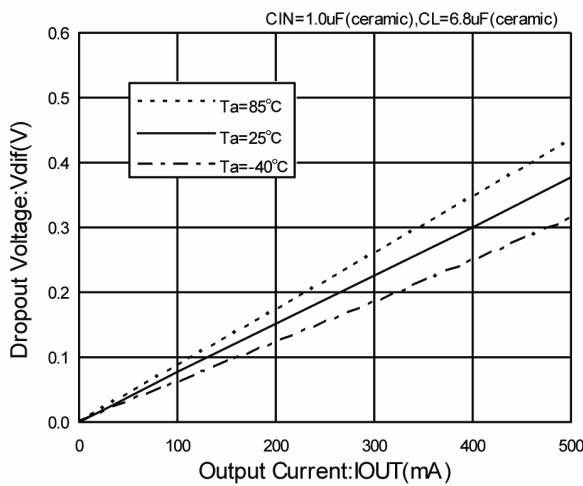

XC6210 (VOUT:2.5V)

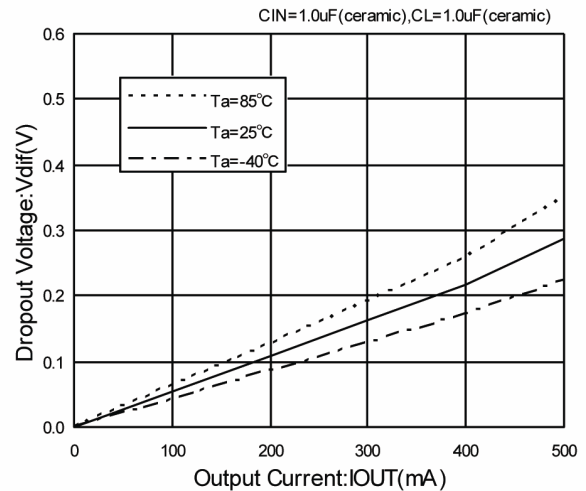

XC6210 (VOUT:3.0V)

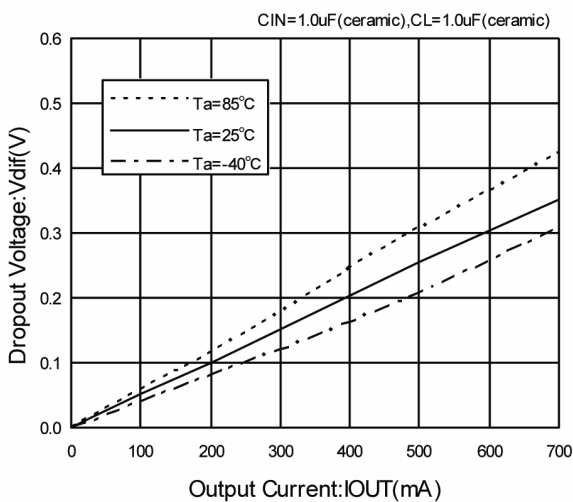

XC6210 (VOUT:5.0V)

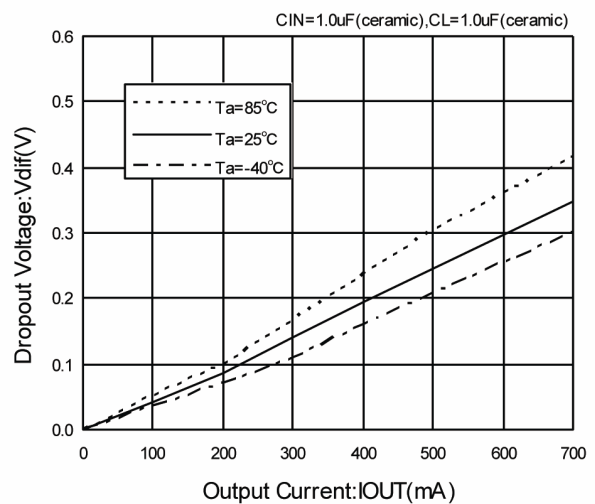

TYPICAL PERFORMANCE CHARACTERISTICS (Continued)

(4) Supply Current vs. Input Voltage

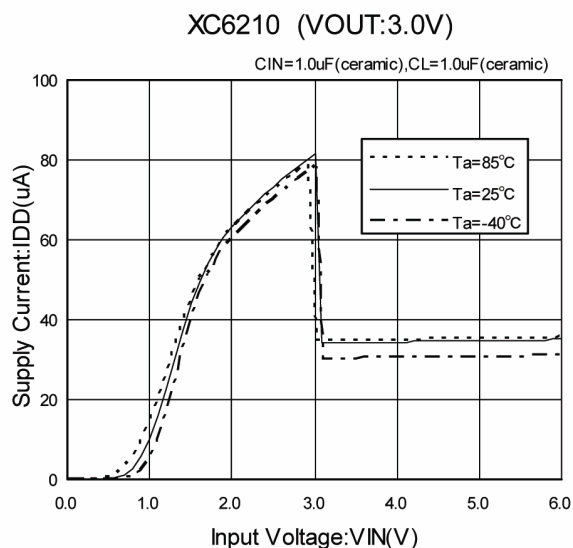
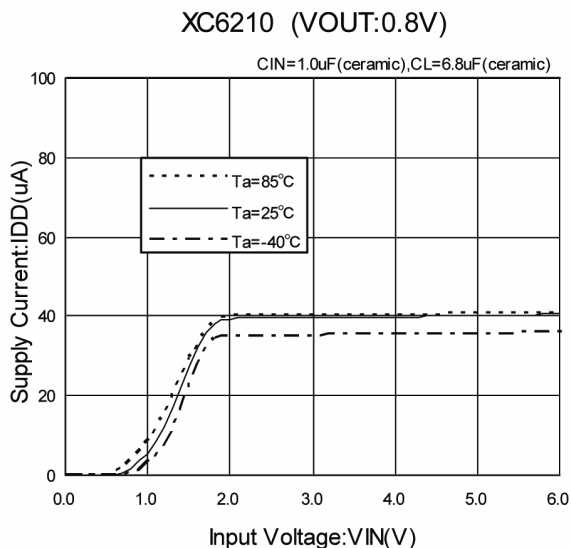

(5) Output Voltage vs. Ambient Temperature

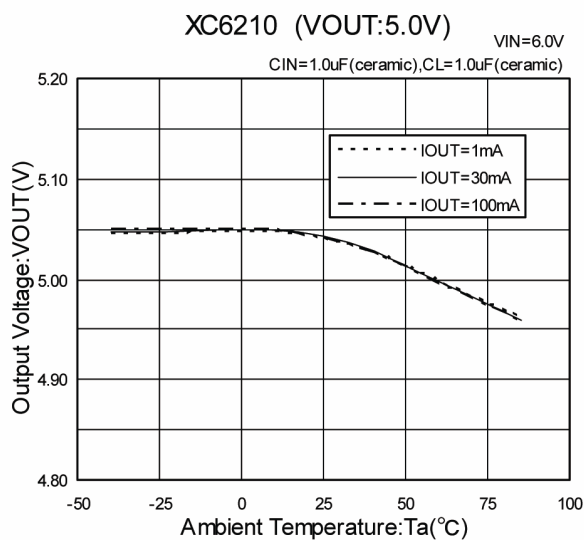
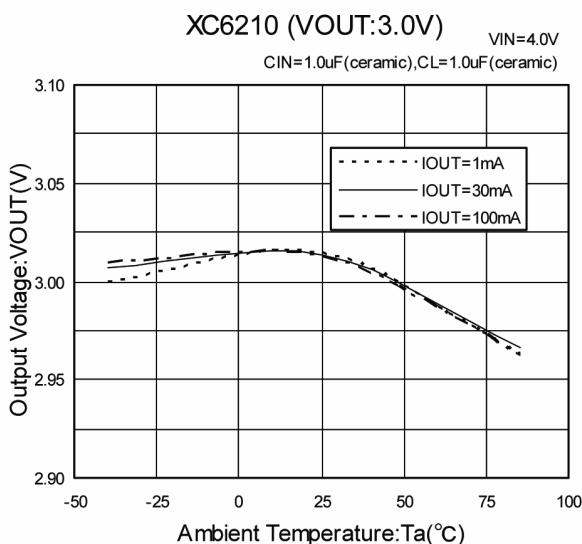
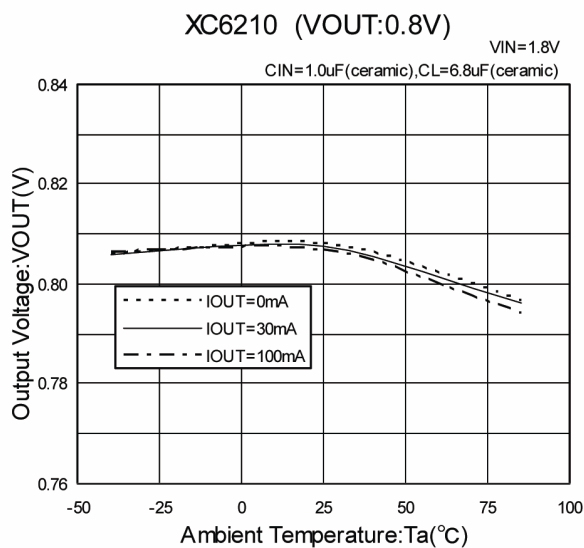
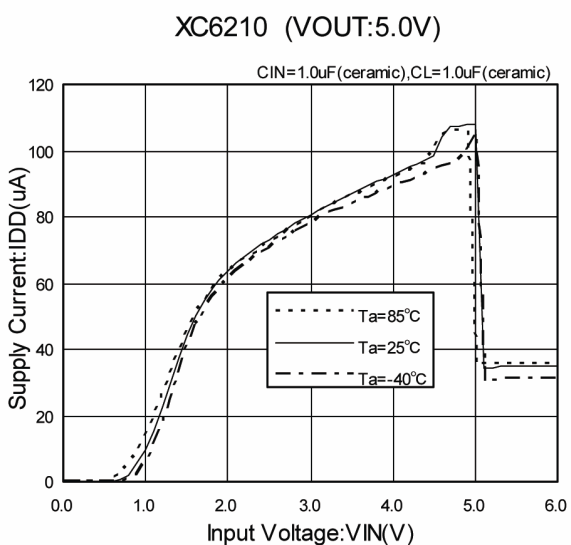

XC6210 Series

TYPICAL PERFORMANCE CHARACTERISTICS (Continued)

(6) Supply Current vs. Ambient Temperature

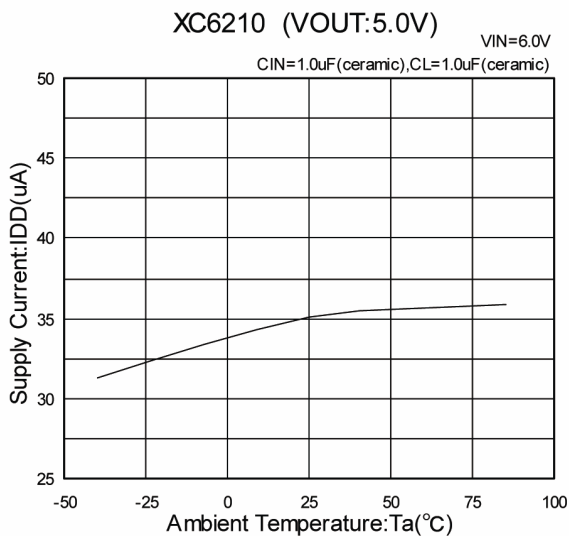
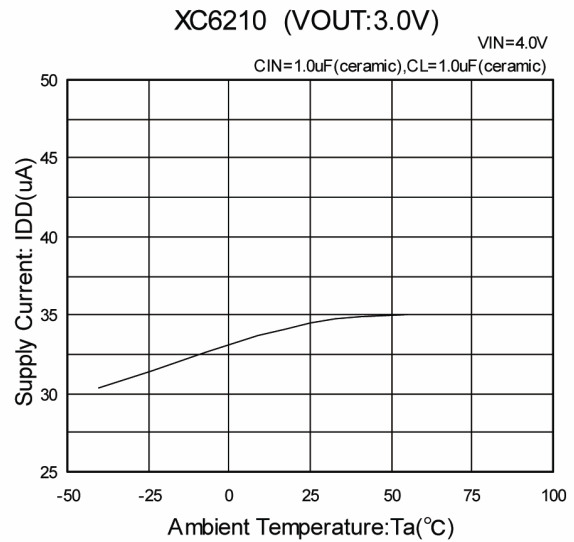
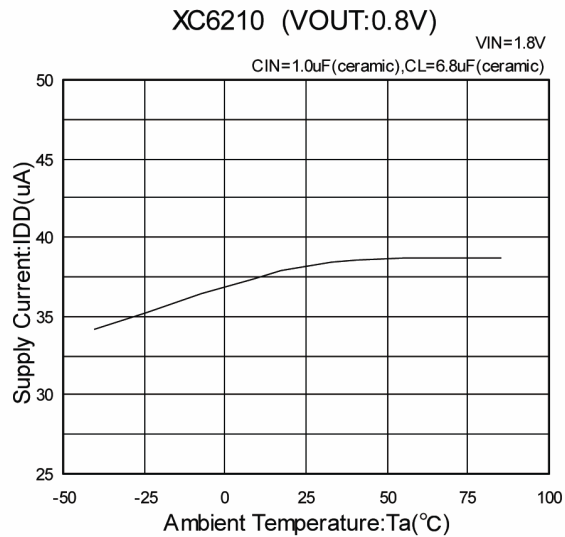

(7) CE Pin Threshold Voltage vs. Ambient Temperature

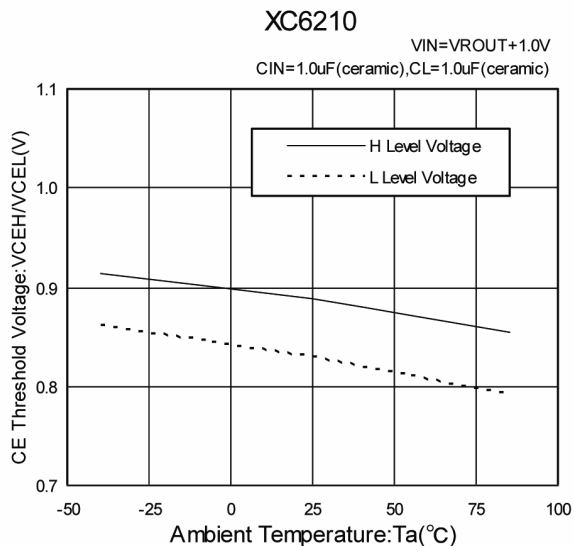

TYPICAL PERFORMANCE CHARACTERISTICS (Continued)

(8) Input Transient Response 1

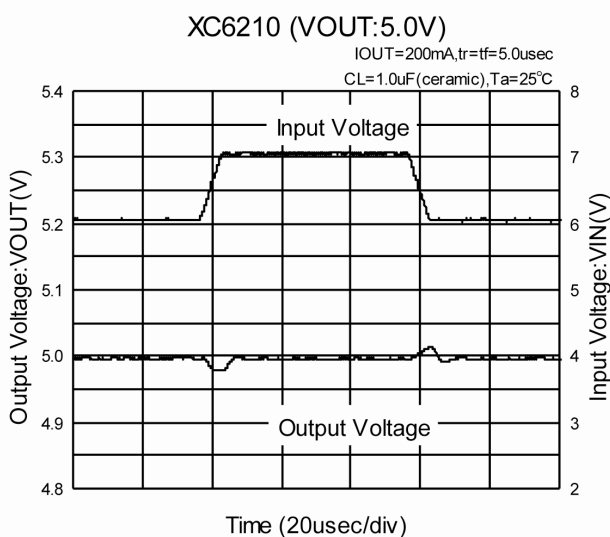
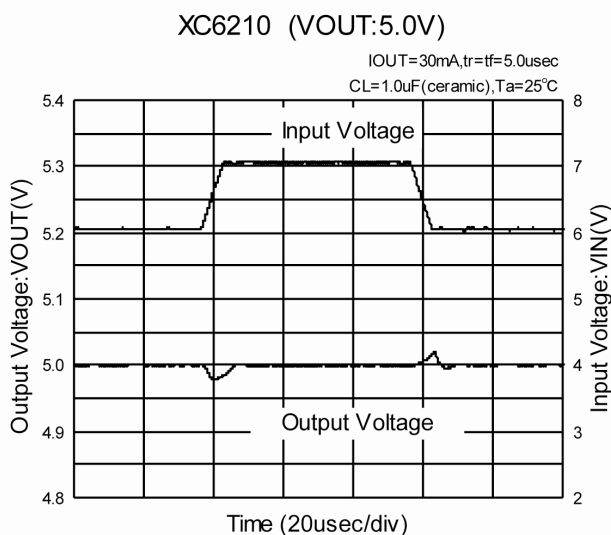
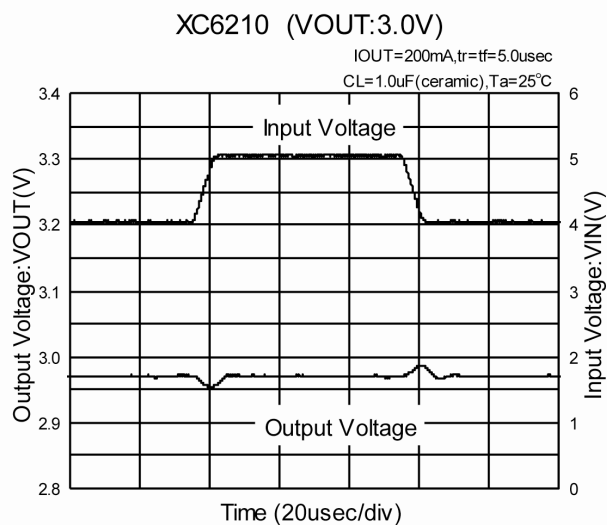
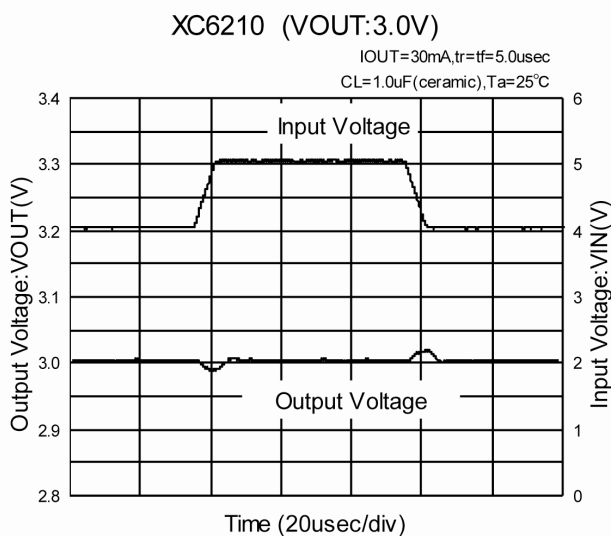
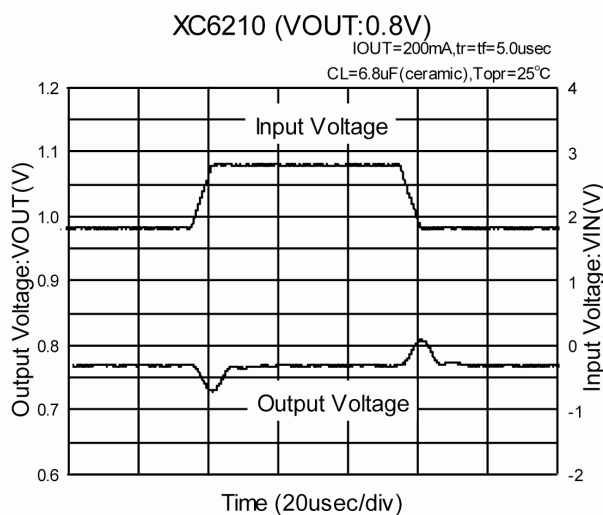
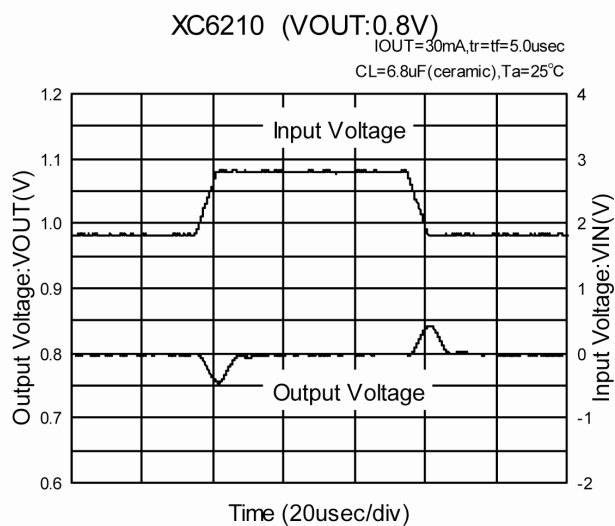

XC6210 Series

TYPICAL PERFORMANCE CHARACTERISTICS (Continued)

(9) Load Transient Response

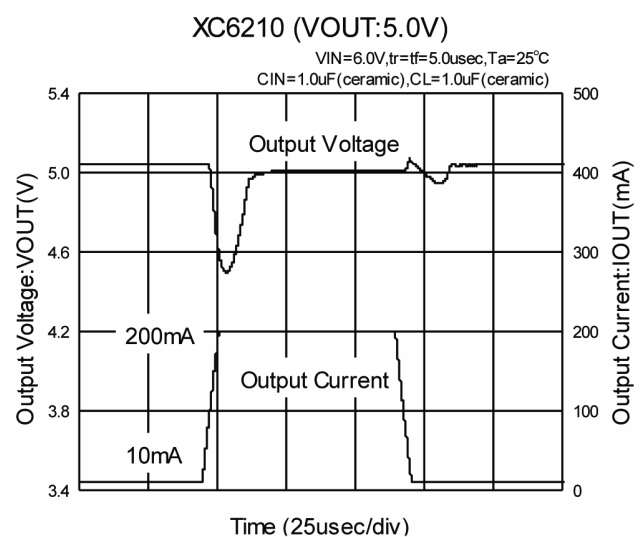
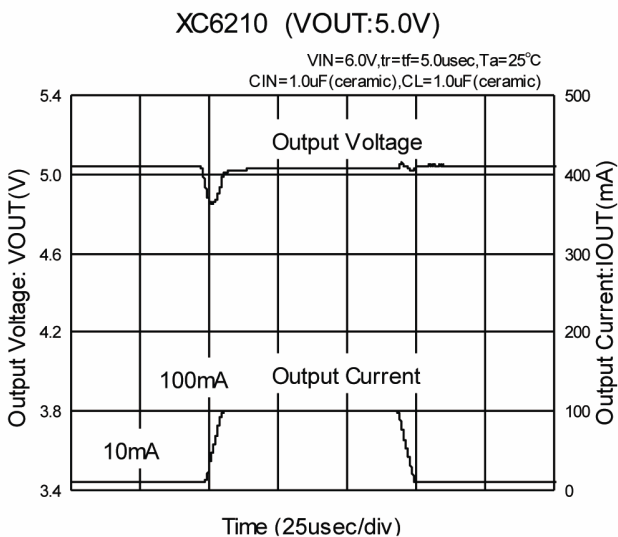
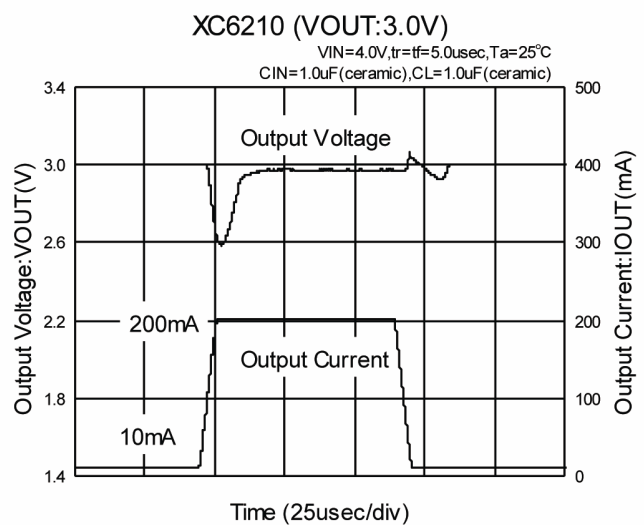
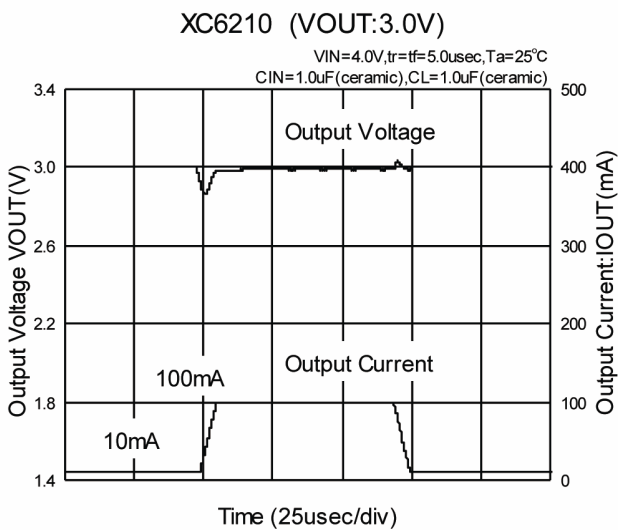
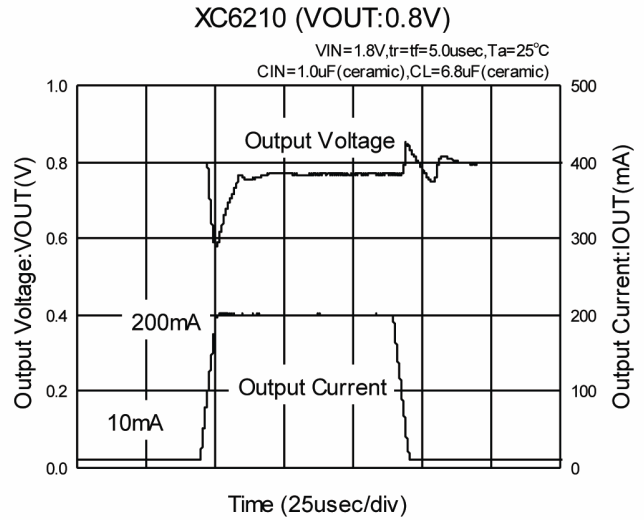
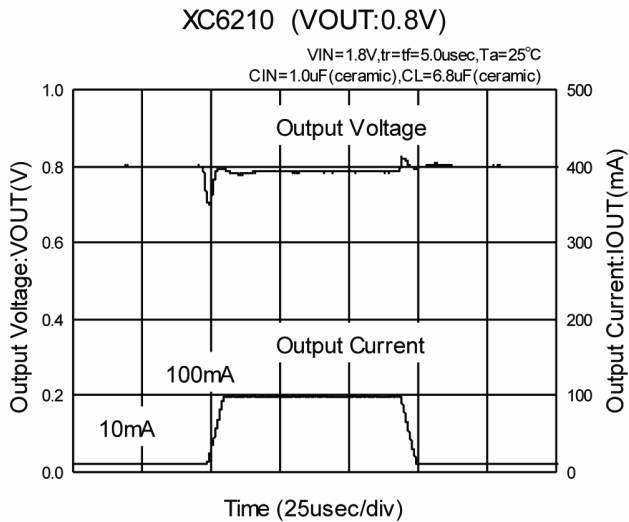

■ TYPICAL PERFORMANCE CHARACTERISTICS (Continued)

(10) Ripple Rejection Rate

XC6210 (VOUT:0.8V)

VIN=1.8VDC+0.5Vp-pAC, IOUT=30mA, Ta=25°C
CIN=1.0uF (ceramic), CL=6.8uF (ceramic)

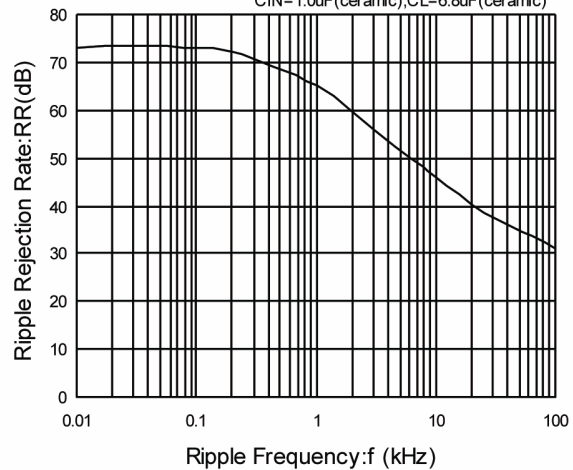

XC6210 (VOUT:3.0V)

VIN=4.0VDC+0.5Vp-pAC, IOUT=30mA, Ta=25°C
CIN=1.0uF (ceramic), CL=1.0uF (ceramic)

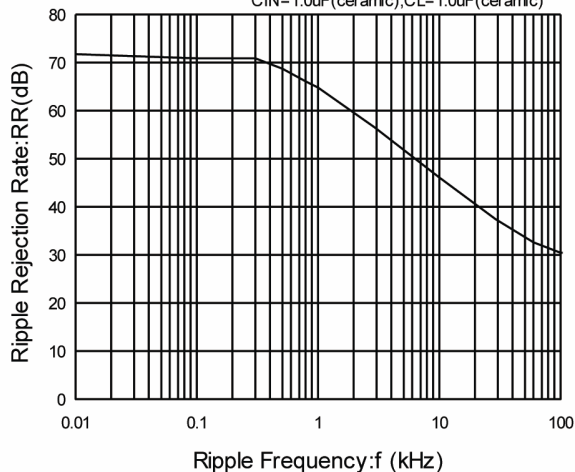

XC6210 (VOUT:5.0V)

VIN=5.75VDC+0.5Vp-pAC, IOUT=30mA, Ta=25°C
CIN=1.0uF (ceramic), CL=1.0uF (ceramic)

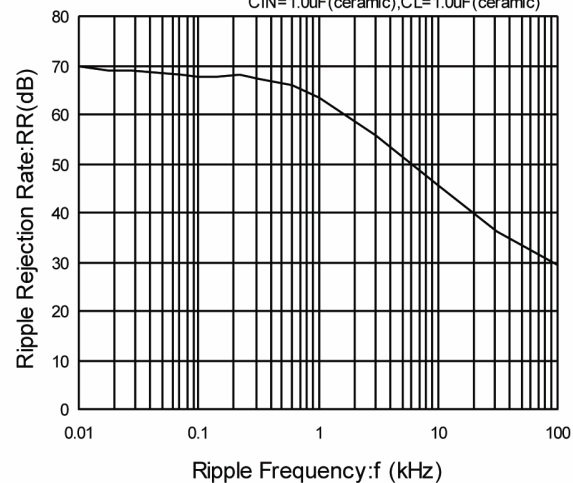

XC6210 Series

TYPICAL PERFORMANCE CHARACTERISTICS (Continued)

(11) Input Transient Response 2

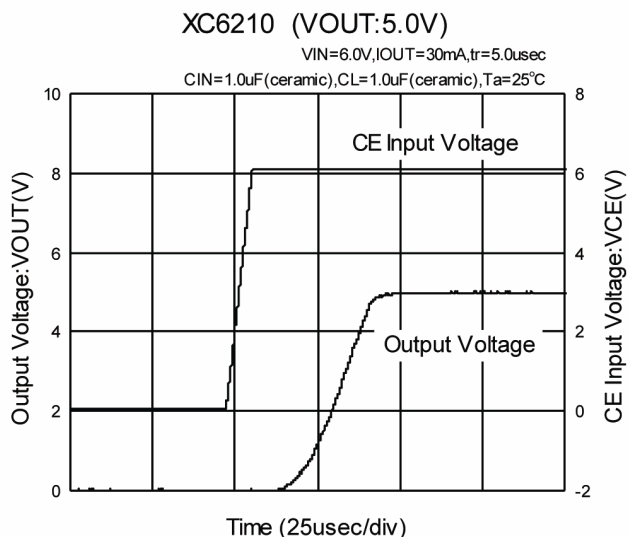
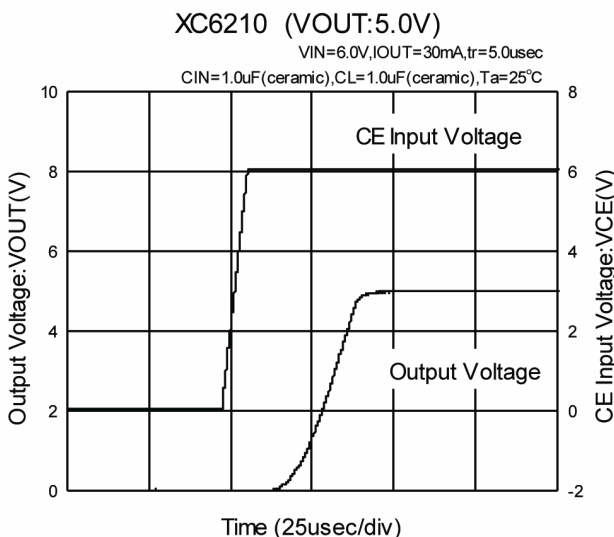
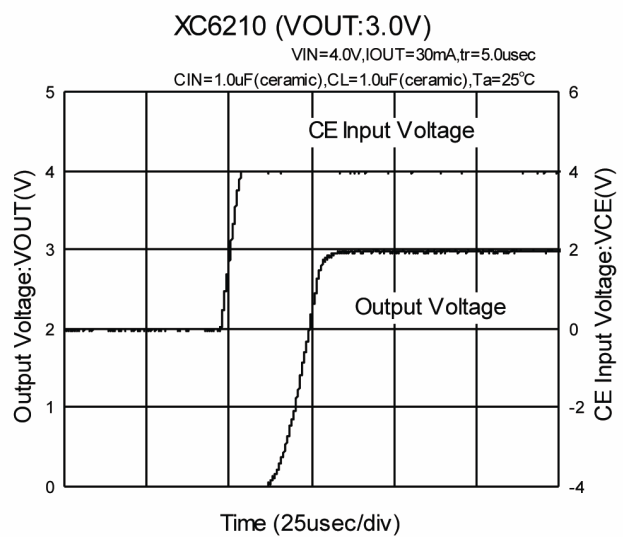
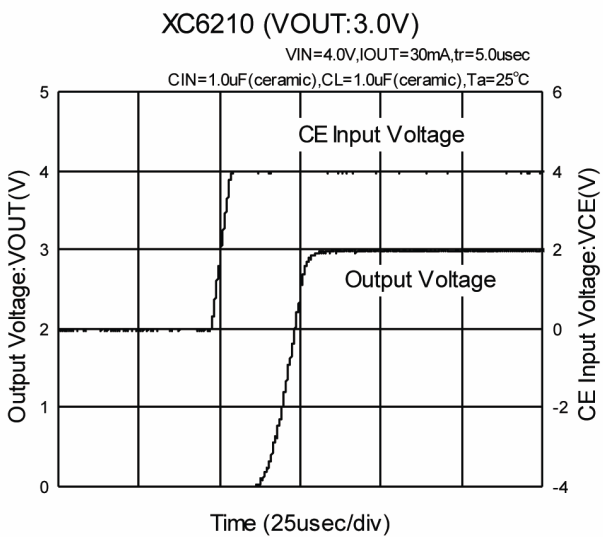
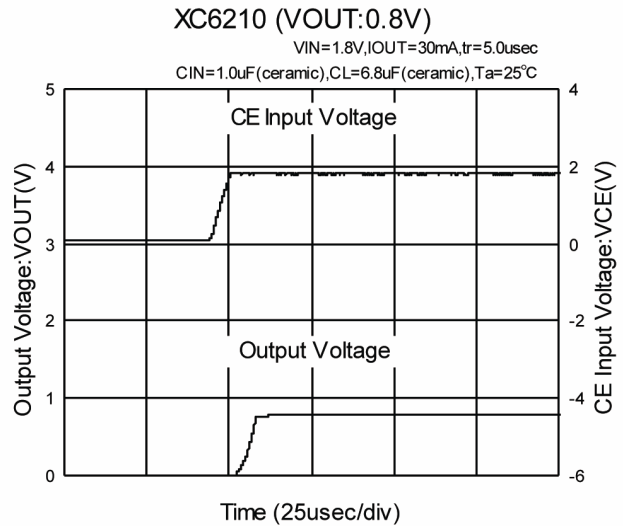
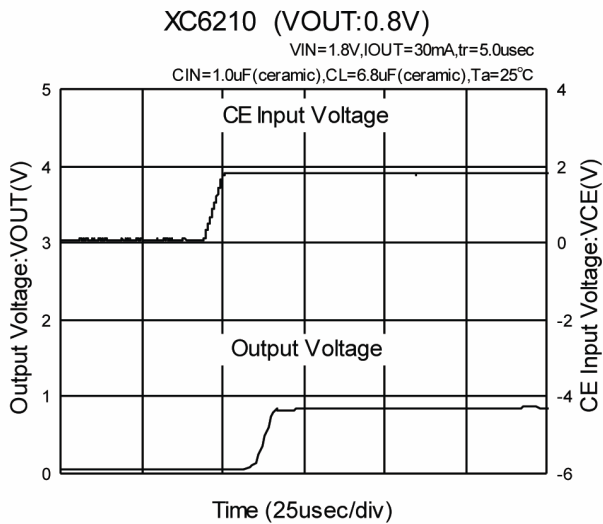

1. The products and product specifications contained herein are subject to change without notice to improve performance characteristics. Consult us, or our representatives before use, to confirm that the information in this catalog is up to date.
2. We assume no responsibility for any infringement of patents, patent rights, or other rights arising from the use of any information and circuitry in this catalog.
3. Please ensure suitable shipping controls (including fail-safe designs and aging protection) are in force for equipment employing products listed in this catalog.
4. The products in this catalog are not developed, designed, or approved for use with such equipment whose failure or malfunction can be reasonably expected to directly endanger the life of, or cause significant injury to, the user.
(e.g. Atomic energy; aerospace; transport; combustion and associated safety equipment thereof.)
5. Please use the products listed in this catalog within the specified ranges.
Should you wish to use the products under conditions exceeding the specifications, please consult us or our representatives.
6. We assume no responsibility for damage or loss due to abnormal use.
7. All rights reserved. No part of this catalog may be copied or reproduced without the prior permission of Torex Semiconductor Ltd.

TOREX SEMICONDUCTOR LTD.

