



GM34063/ GM34063E 1.5A DC-to-DC CONVERTER CONTROL CIRCUIT

Power Management

Description

The GM34063 has all the functions required for DC-to-DC converters: an internal temperature-compensated reference, comparator, controlled duty cycle oscillator with an active current limit circuit, driver, and high-current output switch.

The GM34063 designed for step-down, step-up and voltage-inverting applications using a minimum number of external components.

Features

- ◆ 3.0V to 40V input
- ◆ Adjustable Output Voltage
- ◆ Current Limiting
- ◆ Output Switch Current to 1.5A
- ◆ Low Standby Current
- ◆ Operating Frequency to 100kHz
- ◆ Precision 2% Reference

Application

CD-ROM

Motherboards

SMPS Power Supply

Battery Chargers

DSL Modem

SCHEMATIC DIAGRAM

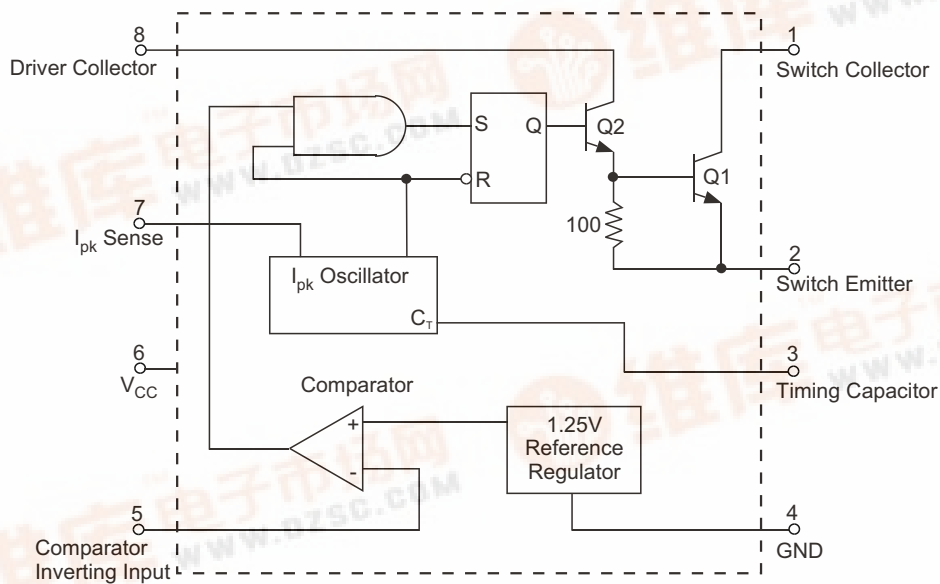

(Bottom View)

* The GM34063 has 51 active transistors on-chip.

Revision 1, May, 2004
GM34063/ GM34063E



◆ MARKING INFORMATION & PIN CONFIGURATIONS (TOP VIEW)

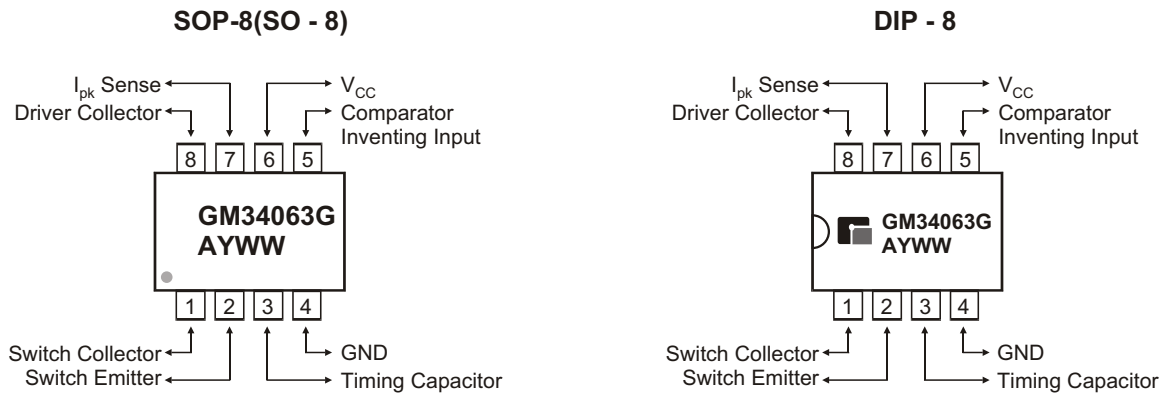

G : Grade (Blank : Operating Ambient Temp. Range [0 to 70°C]
 (E : Operating Ambient Temp. Range [-40 to 125°C])
 A : Assemble Location
 Y : Year
 W W : Work weeks

◆ ORDERING INFORMATION

Ordering Number	Operation Ambient Temperature Range	Package	Shipping
GM34063D8T	0 to 70°C	DIP-8	60 Units/ Tube
GM34063S8T	0 to 70°C	SO-8	100 Units/ Tube
GM34063S8R	0 to 70°C	SO-8	2,500 Units/Tape &Reel
GM34063ED8T	-40 to 125°C	DIP-8	60 Units/ Tube
GM34063ES8T	-40 to 125°C	SO-8	100 Units/ Tube
GM34063ES8R	-40 to 125°C	SO-8	2,500 Units/Tape &Reel

* For detail Ordering Number identification, please see last page.



◆ ABSOLUTE MAXIMUM RATINGS

PARAMETER	SYMBOL	VALUE	UNIT
Power Supply Voltage	V_{CC}	40	Vdc
Comparator Input Voltage Range	V_{IR}	-0.3 to + 40	Vdc
Switch Collector Voltage	$V_{C(Switch)}$	40	Vdc
Switch Emitter Voltage ($V_{PIN1} = 40$ V)	$V_{E(Switch)}$	40	Vdc
Switch Collector to Emitter Voltage	$V_{CE(Switch)}$	40	Vdc
Driver Collector Voltage	$V_{C(driver)}$	40	Vdc
Driver Collector Current(Note 1)	$I_{C(driver)}$	100	mA
Switch Current	I_{SW}	1.5	A
Power Dissipation and Thermal Characteristics			
Plastic Package, D Suffix			
$T_A = 25^\circ\text{C}$	P_D	1.25	W
Thermal Resistance	R_{JA}	100	$^\circ\text{C/W}$
SOIC Package, S Suffix			
$T_A = 25^\circ\text{C}$	P_D	625	mW
Thermal Resistance	R_{JA}	160	$^\circ\text{C/W}$
Operating Junction Temperature	T_J	+150	$^\circ\text{C}$
Operating Ambient Temperature Range			
GM34063	T_A	0 to + 70	$^\circ\text{C}$
GM34063E		-40 to +125	
Storage Temperature Range	T_{STG}	-65 to +150	$^\circ\text{C}$

Note 1. Maximum package power dissipation limits must be observed



◆ **ELECTRICAL CHARACTERISTICS** ($V_{CC} = 5.0\text{ V}$, $T_A = T_{LOW}$ TO Thigh unless otherwise specified)

CHARACTERISTICS	Symbol	Min	Typ	Max	Unit
OSCILLATOR					
Frequency ($V_{pin5} = 0\text{ V}$, $C_T = 1.0\text{ nF}$, $T_A = 25^\circ\text{C}$)	f_{OSC}	24	33	42	kHz
Charge Current ($V_{CC} = 5.0\text{V to }40\text{V}$, $T_A = 25^\circ\text{C}$)	I_{chg}	24	35	42	μA
Discharge Current ($V_{CC} = 5.0\text{V to }40\text{V}$, $T_A = 25^\circ\text{C}$)	I_{dischg}	140	220	260	μA
Discharge to Charge Current Ration (Pin 7 to V_{CC} $T_A = 25^\circ\text{C}$)	I_{dischg} / I_{chg}	5.2	6.5	7.5	-
Current Limit Sense Voltage ($I_{chg} = I_{dischg}$, $T_A = 25^\circ\text{C}$)	$V_{ipk(sense)}$	250	300	350	mV
OUTPUT SWITCH (Note 2)					
Saturation Voltage, Darlington Connection ($I_{SW} = 1.0\text{A}$, Pins 1, 8 connected)	$V_{CE(sat)}$	-	1.0	1.3	V
Saturation Voltage (Note 3) ($I_{SW} = 1.0\text{ A}$, $R_{Pins\ 8} = 82\ \Omega$ to V_{CC} , Forced ≈ 20)	$V_{CE(sat)}$	-	0.45	0.7	V
DC Current Gain ($I_{SW} = 1.0\text{ A}$, $V_{EC} = 5.0\text{ V}$, $T_A = 25^\circ\text{C}$)	h_{FE}	50	75	-	-
Collector Off - State Current ($V_{CE} = 40\text{ V}$)	$I_{C(Off)}$	-	40	100	μA
COMPARATOR					
Threshold Voltage $T_A = 25^\circ\text{C}$ $T_A = T_{LOW}$ to T_{high}	V_{th}	1.225 1.210	1.25 -	1.275 1.29	V
Threshold Voltage Line Regulation ($V_{CC} = 3.0\text{V to }40\text{V}$)	Reg_{line}	-	1.4	5.0	mV
Input Bias Current ($V_{IN} = 0\text{V}$)	I_{IB}	-	-20	-400	nA
TOTAL DEVICE					
Supply Current ($V_{CC} = 5.0\text{V to }40\text{ V}$, $C_T = 1.0\text{ nF}$, Pin 7 = V_{CC} $V_{pin5} > V_{th}$ Pin 2 = GND remaining pins open)	I_{CC}	-	-	4.0	mA

Note 2. Low duty cycle pulse techniques are used during test to maintain junction temperature as close to ambient as possible.

Note 3. If the output switch is driven into hard saturation (non-arlington configuration) at low switch currents ($\leq 300\text{ mA}$) and high driver currents ($\geq 30\text{ mA}$), it may take up to 2.0 ms for it to come out of saturation. This condition will shorten the off time at frequencies $\leq 30\text{ kHz}$, and is magnified at high temperatures. This condition does not occur with a Darlington configuration, since the output switch cannot saturate. If a non-Darlington configuration is used, the following output drive condition is recommended:

Forced of output switch :

$$\frac{I_C \text{ output}}{I_C \text{ driver} - 7.0\text{ mA}^*} \geq 10$$

* The 100 Ω resistor in the emitter of the driver device requires about 7.0 mA before the output switch conducts.



◆ Typical Performance Characteristics

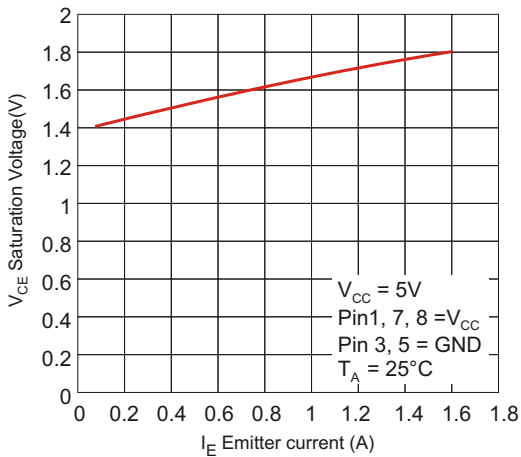

Figure 1: Emitter Follows Configuration Output

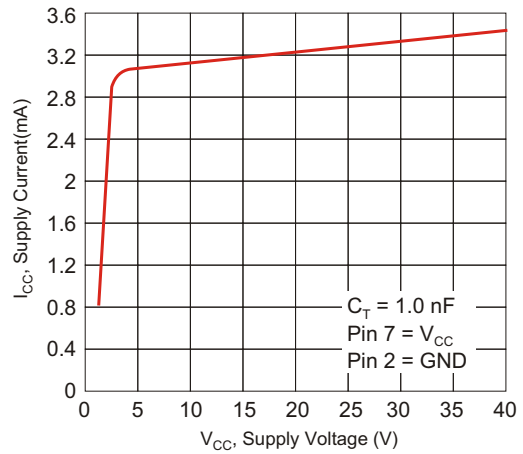

Figure 2: Standby Supply Current Versus Supply Voltage

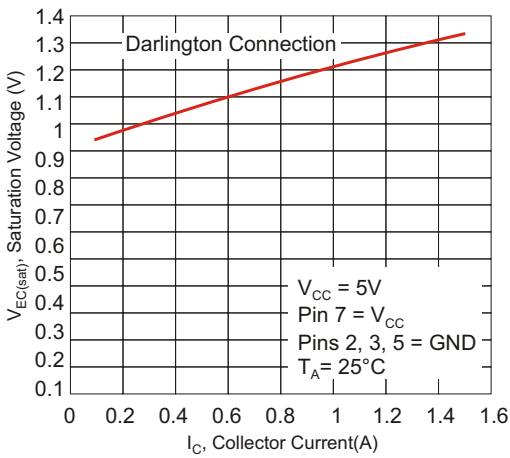

Figure 3: Common Emitter Configuration Output Switch Saturation Voltage versus Collector Current

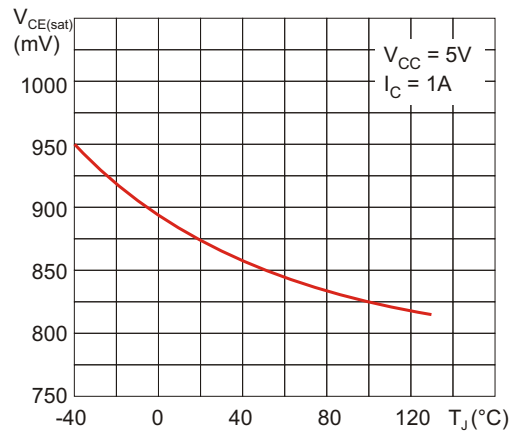

Figure 4: Darlington Configuration Collector Emitter Saturation Voltage ($V_{CE(sat)}$) vs Temperature

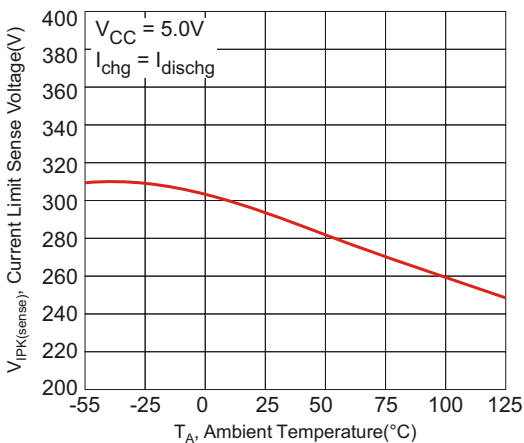

Figure 5: Current Limit Sense Voltage versus Temperature

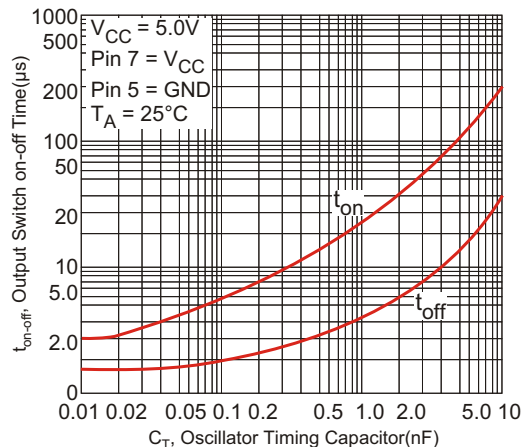
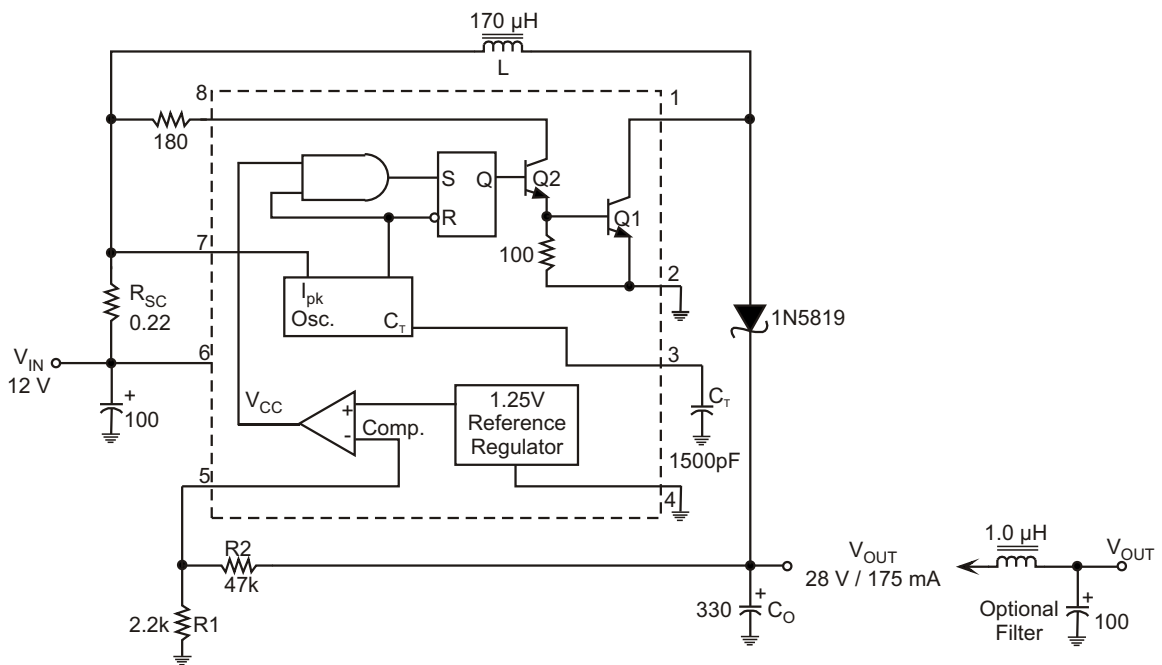

Figure 6: Output Switch On-Off Time versus Oscillator Timing Capacitor

◆ Figure 7. External Current Boost Connections for I_C Peak Greater than 1.5A

Test	Conditions	Results
Line Regulation	$V_{IN} = 8.0\text{ V to }16\text{ V}, I_O = 175\text{ mA}$	30 mV = $\pm 0.05\%$
Load Regulation	$V_{IN} = 12\text{ V}, I_O = 75\text{ mA to }175\text{ mA}$	10mV = $\pm 0.017\%$
Output Ripple	$V_{IN} = 12\text{ V}, I_O = 175\text{ mA}$	400 mVpp
Efficiency	$V_{IN} = 12\text{ V}, I_O = 175\text{ mA}$	87.7%
Output Ripple With Optional Fitter	$V_{IN} = 12\text{ V}, I_O = 175\text{ mA}$	40 mVpp

◆ Step - Up Converter



◆ External Current Boost Connections for I_c Peak Greater than 1.5A

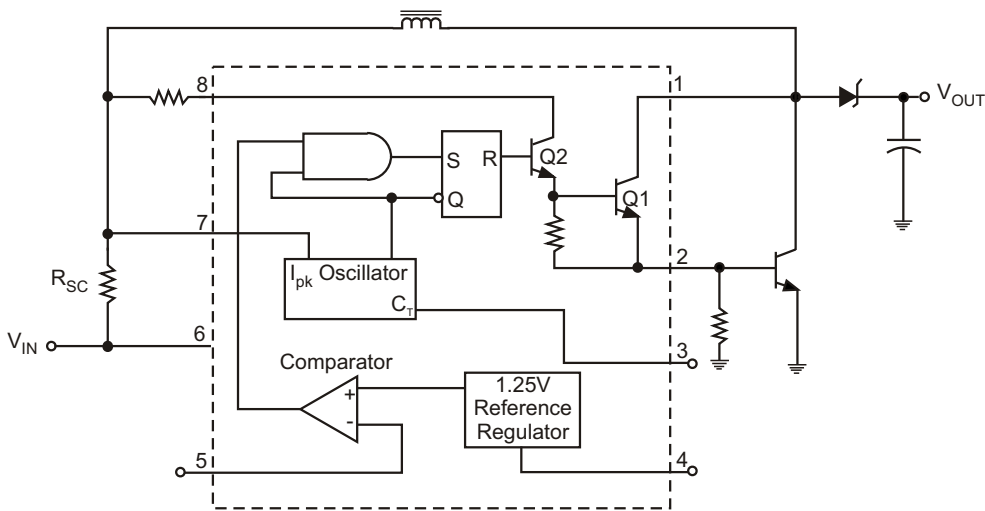

Figure 6a. External NPN Switch

If the output switch is driven into hard saturation (non-Darlington configuration) at low switch currents (≤ 300 mA) and high driver currents (≥ 30 mA), it may take up to 2.0 ms to come out of saturation. This condition will shorten the off time at frequencies ≥ 30 kHz, and is magnified at high temperatures. This condition does not occur with a Darlington configuration, since the output switch cannot saturate. If a non-Darlington configuration is used, the following output drive condition is recommended.

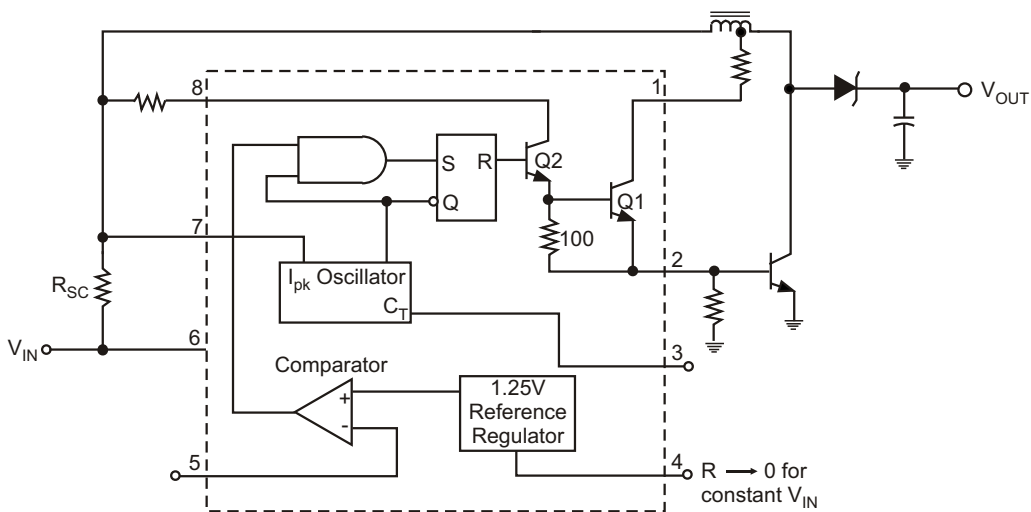

Figure 6b. External NPN Switch



◆ Figure 8. External Current Boost Connections for I_C Peak Greater than 1.5A

Test	Conditions	Results
Line Regulation	$V_{IN} = 15\text{ V to }25\text{ V}, I_O = 500\text{ mA}$	$12\text{ mV} = \pm 0.15\%$
Load Regulation	$V_{IN} = 25\text{ V}, I_O = 75\text{ mA to }500\text{ mA}$	$3.5\text{ mV} = \pm 0.03\%$
Output Ripple	$V_{IN} = 25\text{ V}, I_O = 500\text{ mA}$	120 mVpp
Short Circuit Current	$V_{IN} = 25\text{ V}, R_L = 0.1$	1.1 A
Efficiency	$V_{IN} = 25\text{ V}, I_O = 500\text{ mA}$	83.7%
Output Ripple With Optional Fitter	$V_{IN} = 25\text{ V}, I_O = 500\text{ mA}$	40 mVpp

◆ Step - Down Converter

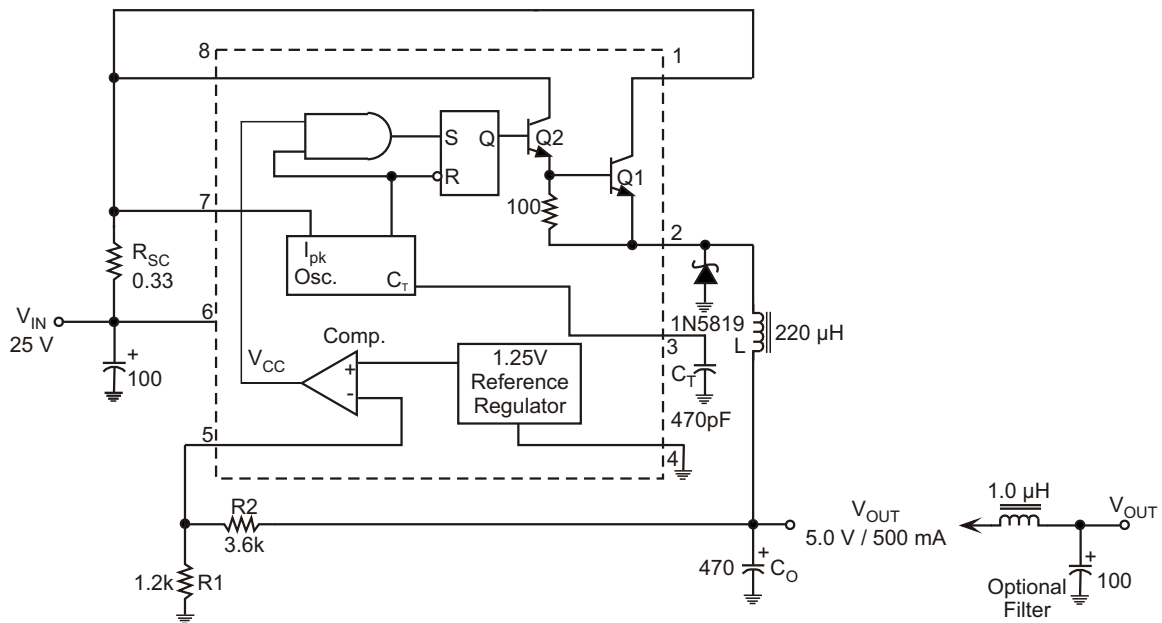

◆ External Current Boost Connections for I_c Peak Greater than 1.5A

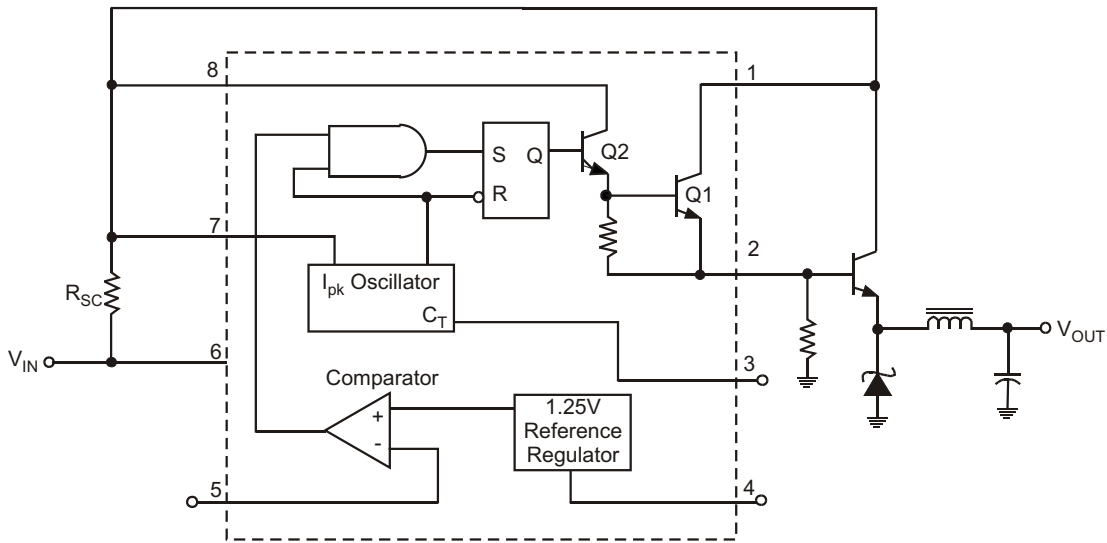

Figure 7a. External NPN Switch

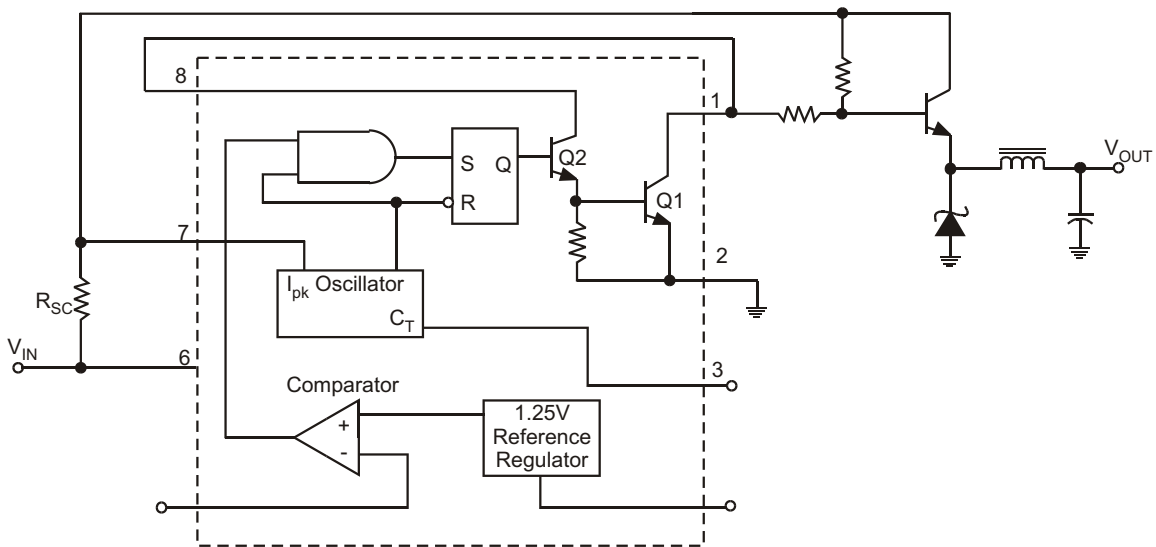
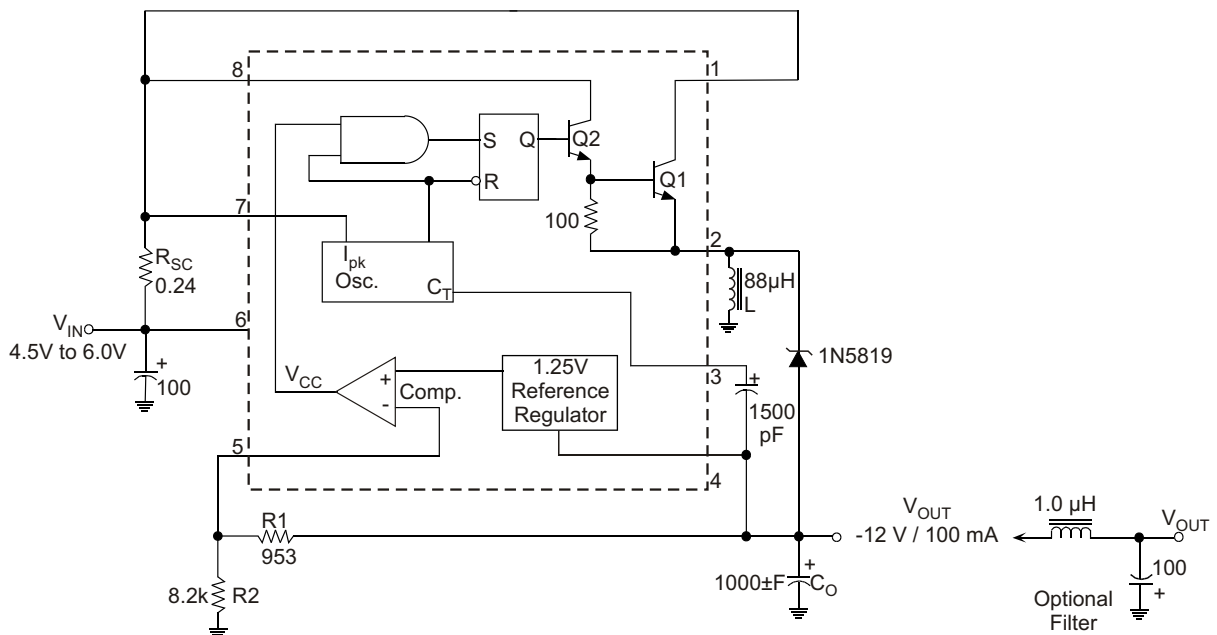

Figure 7b. External NPN Switch

◆ Figure 9. External Current Boost Connections for I_c Peak Greater than 1.5A

Test	Conditions	Results
Line Regulation	$V_{IN} = 4.5\text{ V to }6.0\text{ V}, I_O = 100\text{ mA}$	$3.0\text{ mV} = \pm 0.012\%$
Load Regulation	$V_{IN} = 5.0\text{ V}, I_O = 10\text{ mA to }100\text{ mA}$	$0.022\text{ mV} = \pm 0.09\%$
Output Ripple	$V_{IN} = 5.0\text{ V}, I_O = 100\text{ mA}$	500 mVpp
Short Circuit Current	$V_{IN} = 5.0\text{ V}, R_L = 0.1$	910 mA
Efficiency	$V_{IN} = 5.0\text{ V}, I_O = 100\text{ mA}$	62.2%
Output Ripple With Optional Fitter	$V_{IN} = 5.0\text{ V}, I_O = 100\text{ mA}$	70 mVpp

◆ Voltage Inverting Converter



◆ External Current Boost Connections for I_c Peak Greater than 1.5A

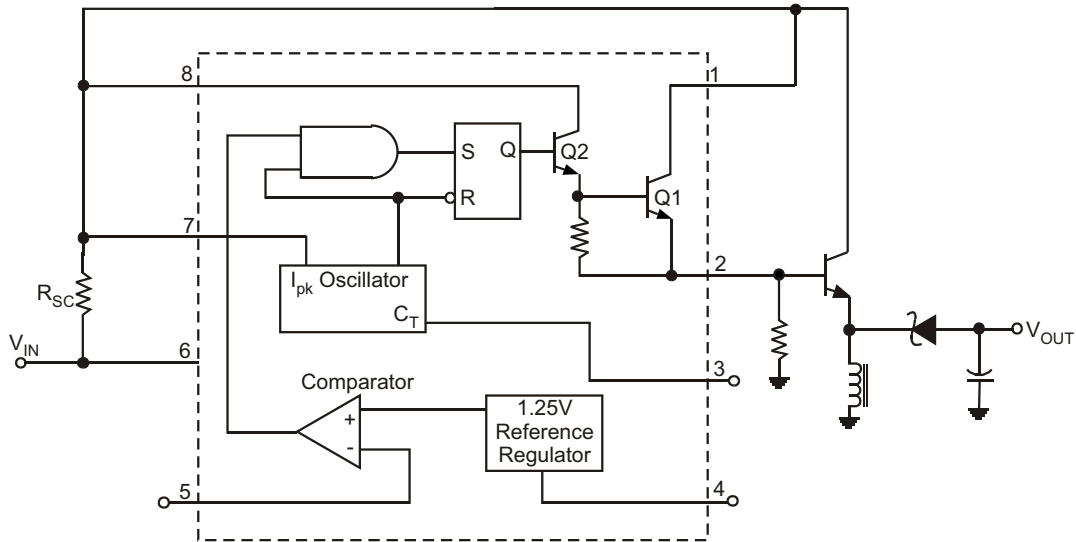

Figure 8a. External NPN Switch

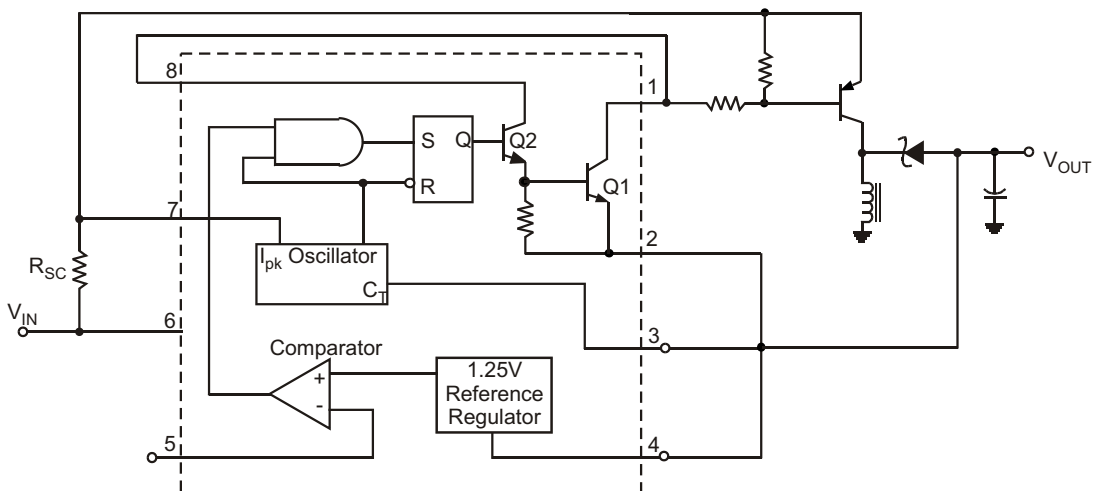

Figure 8b. External NPN Switch

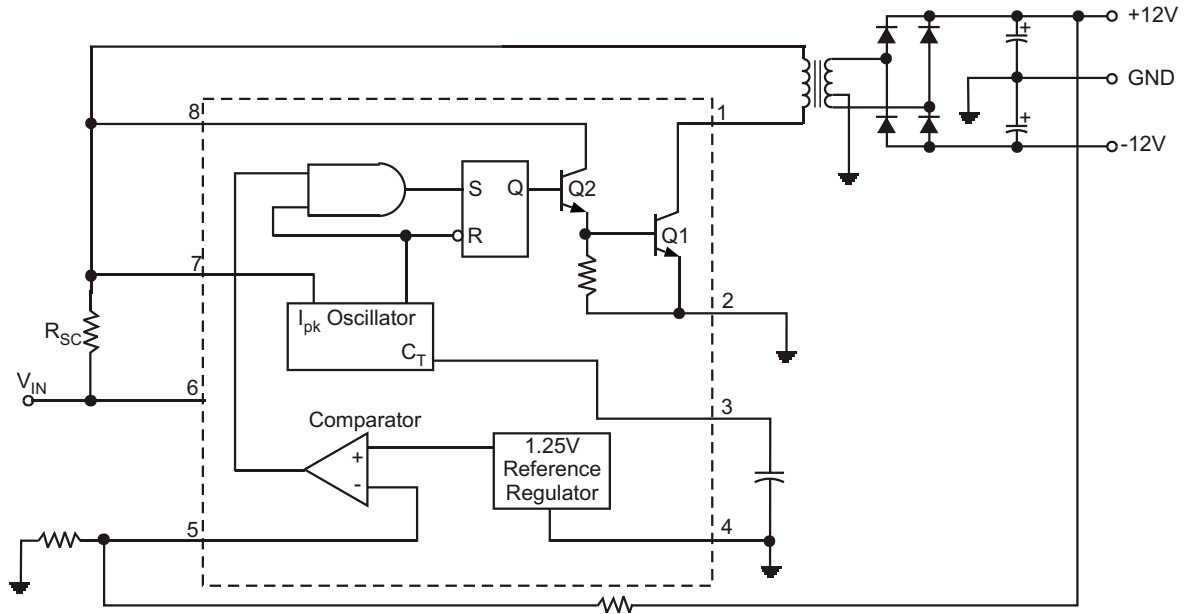

Figure 9. Dual Output Voltage

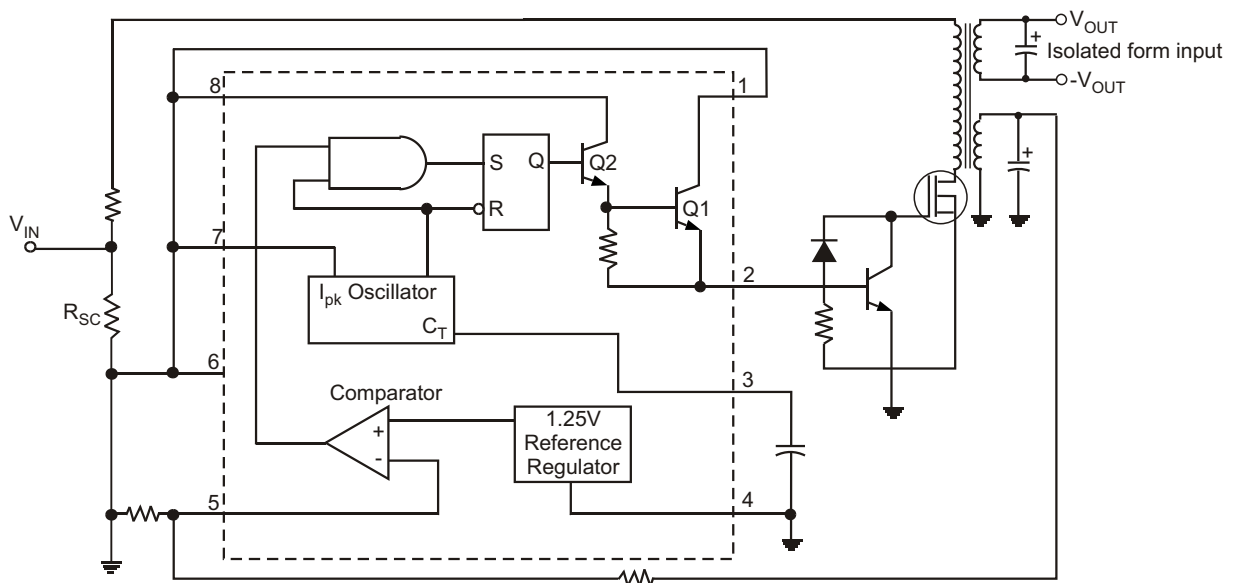

Figure 10. Higher Output Power, Higher Input Voltage



◆ DESIGN FORMULAS

Calculation	Step - Up	Step - Down	Voltage - Inverting
t_{on} / t_{off}	$\frac{V_{out} + V_F - V_{IN(min)}}{V_{IN(min)} - V_{sat}}$	$\frac{V_{out} + V_F}{V_{IN(min)} - V_{sat} - V_{out}}$	$\frac{ V_{out} + V_F}{V_{IN} - V_{sat}}$
$(t_{on} + t_{off})$	$\frac{1}{f}$	$\frac{1}{f}$	$\frac{1}{f}$
t_{off}	$\frac{t_{on} + t_{off}}{\frac{t_{on}}{t_{off}} + 1}$	$\frac{t_{on} + t_{off}}{\frac{t_{on}}{t_{off}} + 1}$	$\frac{t_{on} + t_{off}}{\frac{t_{on}}{t_{off}} + 1}$
t_{on}	$(t_{on} + t_{off}) - t_{on}$	$(t_{on} + t_{off}) - t_{on}$	$(t_{on} + t_{off}) - t_{on}$
C_T	$4.0 \times 10^{-5} t_{on}$	$4.0 \times 10^{-5} t_{on}$	$4.0 \times 10^{-5} t_{on}$
$I_{pk(switch)}$	$2 I_{out(max)} \left(\frac{t_{on}}{t_{off}} + 1 \right)$	$2 I_{out(max)}$	$2 I_{out(max)} \left(\frac{t_{on}}{t_{off}} + 1 \right)$
R_{SC}	$0.3 / I_{pk(switch)}$	$0.3 / I_{pk(switch)}$	$0.3 / I_{pk(switch)}$
$L_{(min)}$	$\left(\frac{V_{IN(min)} - V_{sat}}{I_{pk(switch)}} \right) t_{on(max)}$	$\left(\frac{V_{IN(min)} - V_{sat} - V_{out}}{I_{pk(switch)}} \right) t_{on(max)}$	$\left(\frac{V_{IN(min)} - V_{sat}}{I_{pk(switch)}} \right) t_{on(max)}$
C_O	$9 \frac{I_{out} t_{on}}{V_{ripple(pp)}}$	$\frac{I_{pk(switch)} (t_{on} + t_{off})}{8 V_{ripple(pp)}}$	$9 \frac{I_{out} t_{on}}{V_{ripple(pp)}}$

V_{sat} = Saturation voltage of the output switch.

V_F = Forward voltage drop of the output rectifier.

V_{IN} - Nominal input voltage.

V_{out} - Desired output voltage,

I_{out} - Desired output current.

f_{min} - Minimum desired output switching frequency at the selected values of V_{IN} and I_O .

$V_{ripple(pp)}$ - Desired peak-to peak output ripple voltage. In practice, the calculated capacitor value will need to be increased due to its equivalent series resistance and board layout. The ripple voltage should be kept to a low value since it will directly affect the line and load regulation.

◆ SOP-8(SO-8) PACKAGE OUTLINE DIMENSIONS

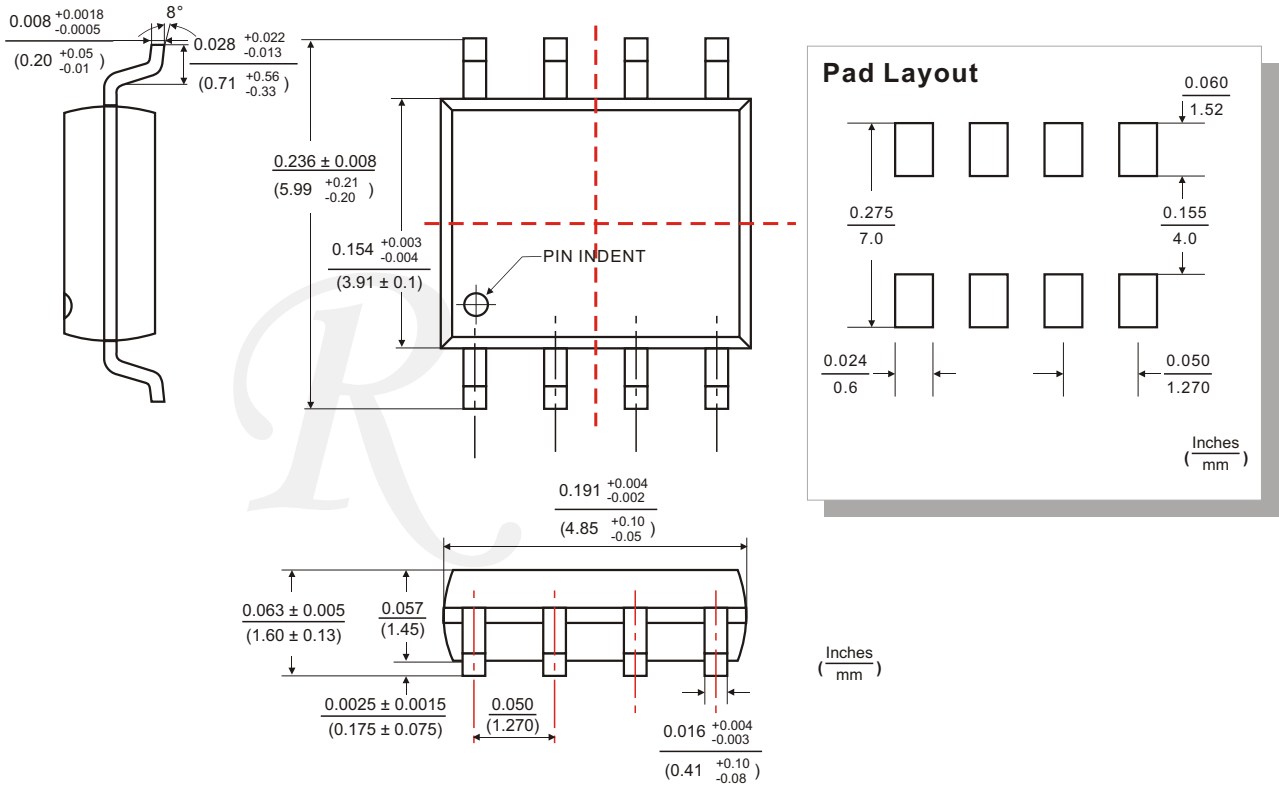

◆ DIP-8 PACKAGE OUTLINE DIMENSIONS

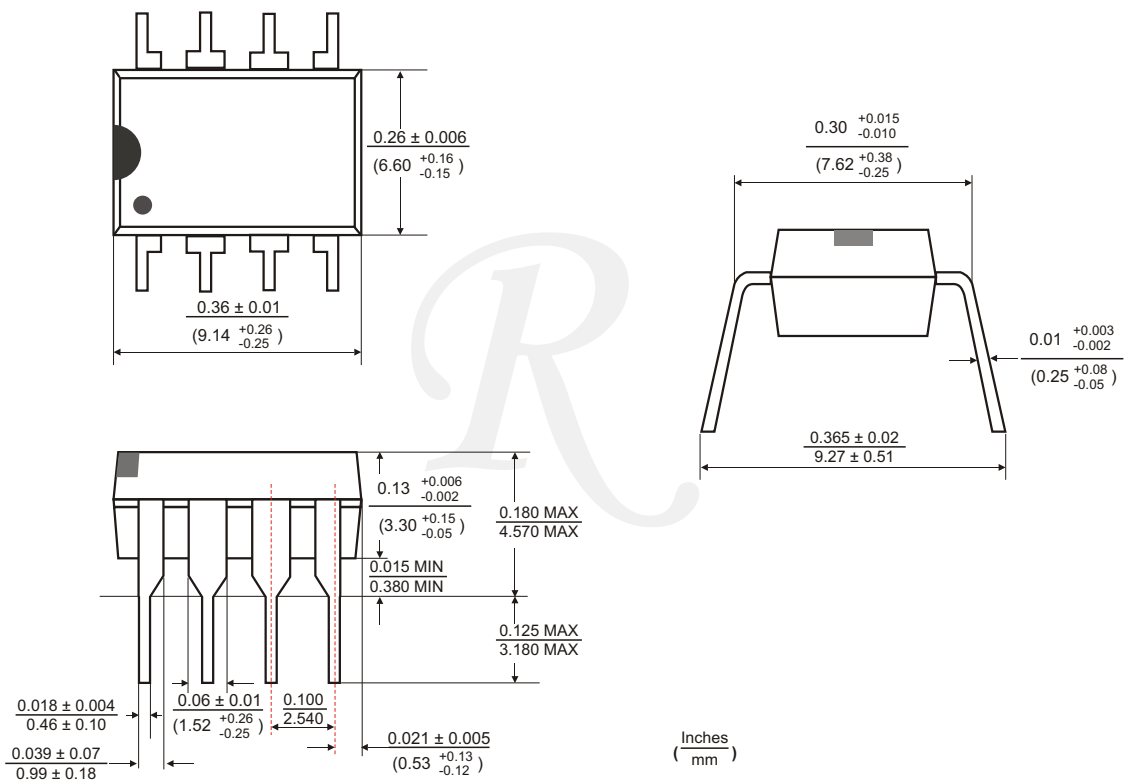

◆ ORDERING NUMBER

