



SanKen Power Devices
from Allegro MicroSystems

Switching
Regulators



Package DIP-8

Approximate Scale 1:1



STR-A6259H

Universal-Input 13 W 100 kHz Flyback Switching Regulators

The STR-A6259H is a 100 kHz PWM topology (with $\pm 5\%$ frequency jittering for minimum EMI) regulator specifically designed to satisfy the requirements for increased integration and reliability in flyback converters. It incorporates a primary control and drive circuit with an avalanche-rated power MOSFET.

Covering the power range from below 17 watts for a 230 VAC input, or to 13 watts for a universal (85 to 264 VAC) input, this device can be used in a wide range of applications, from DVD players and VCR player/recorders to ac adapters for cellular phones and digital cameras. An auto-burst standby function reduces power consumption at light load, while multiple protections, including the avalanche-energy guaranteed MOSFET, provide high reliability of system design.

Cycle-by-cycle current limiting, undervoltage lockout with hysteresis, overvoltage protection, and thermal shutdown protect the power supply during the normal overload and fault conditions. Overvoltage protection and thermal shutdown are latched after a short delay. The latch may be reset by cycling the input supply. Low start-up current and a low-power standby mode selected from the secondary circuit completes a comprehensive suite of features.

It is provided in an 8-pin mini-DIP plastic package with pin 6 removed. The leadframe plating is pure Sb, and the package complies with RoHS.

FEATURES AND BENEFITS

- 100 kHz PWM with $\pm 5\%$ frequency jittering for EMI noise filtering cost reduction
- Rugged 650 V avalanche-rated MOSFET:
 - Simplified surge absorption
 - No V_{DSS} derating required
- Low $R_{DS(on)}$: 6 Ω maximum
- Auto-burst mode for stand-by operation or light loads; less transformer audible noise
- Built-in leading edge blanking
- Soft start and low start-up current; start-up circuit disabled in operation
- Auto-burst stand-by (intermittent operation) input power <0.1 W at no load
- Built-in constant-voltage/constant current (CV/CC)
- Multiple protections:
 - Pulse-by-pulse overcurrent protection (OCP)
 - Overload protection (OLP) with auto restart
 - Latching overvoltage protection (OVP)
 - Undervoltage lockout (UVLO) with hysteresis
 - Latching thermal shutdown (TSD)



Always order by complete part number, e.g.: **STR-A6259H**

STR-A6259H
Universal Input 13 W 100 kHz
Flyback Switching Regulators

*Switching
Regulators*

FUNCTIONAL BLOCK DIAGRAM AND TERMINAL ASSIGNMENTS

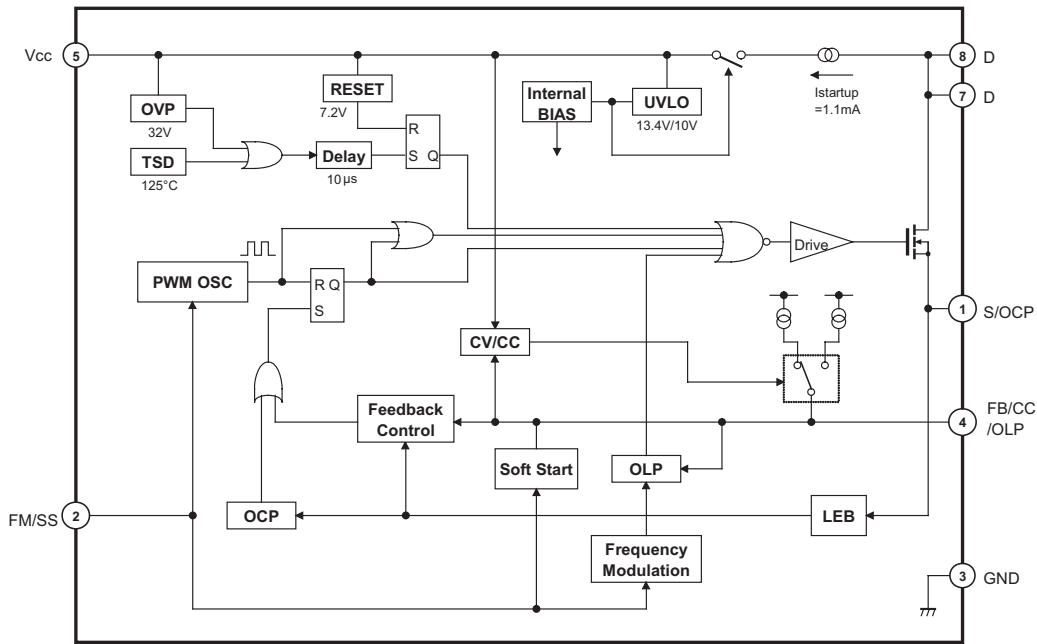

| Number | Name | Description | Functions |
|--------|------------|------------------------|--|
| 1 | S/OCP | Source/OCP terminal | MOSFET Source/Overcurrent protection |
| 2 | FM/SS | FM/Soft start terminal | Capacitor connection terminal for frequency jitter and soft start. |
| 3 | GND | Ground terminal | Ground |
| 4 | FB /CC/OLP | FB/CC/OLP terminal | Input of constant voltage control signal / constant current operation control signal / over load protection signal |
| 5 | VCC | Power supply terminal | Input of power supply for control circuit |
| 7 | D | Drain terminals | MOSFET drain / Input of startup current |
| 8 | | | |

STR-A6259H

Universal Input 13 W 100 kHz

Flyback Switching Regulators

Switching
Regulators

ABSOLUTE MAXIMUM RATINGS at $T_A = 25^\circ\text{C}$

| Characteristic | Symbol | Terminal | Note | Max. | Unit |
|---|-------------|----------|---|------------|------------------|
| Drain Current ¹ | I_{Dpeak} | 8-1 | Single Pulse | 1.8 | A |
| Maximum Switching Current | I_{Dmax} | 8-1 | $V_{S/OCV} = 0.83\text{ V}$ with reference to GND, $T_A = -20\text{ to }125^\circ\text{C}$ | 1.8 | A |
| Single Pulse Avalanche Energy ² | E_{AS} | 8-1 | Single Pulse | 24 | mJ |
| | | | $V_{DD} = 99\text{ V}$, $L = 20\text{ mH}$, $I_L = 1.8\text{ A}$ | 24 | mJ |
| S/OCP Terminal Voltage | V_{OCP} | 1-3 | | -0.3 to 6 | V |
| Controller (MIC) Input Voltage | V_{CC} | 5-3 | | 36 | V |
| FB/CC/OLP Terminal Voltage | V_{FB} | 4-3 | | -0.3 to 11 | V |
| FM Terminal Voltage | V_{FM} | 2-3 | | -0.3 to 6 | V |
| MOSFET Power Dissipation ^{3,4} | P_{D1} | 8-1 | | 1.35 | W |
| Controller (MIC) Power Dissipation ⁵ | P_{D2} | 5-3 | For $V_{CC} \times I_{CC}$ | 0.15 | W |
| Operating Internal Frame Temperature ⁶ | T_F | | Refer to T_{OP} | -20 to 125 | $^\circ\text{C}$ |
| Operating Ambient Temperature | T_{OP} | | | -20 to 125 | $^\circ\text{C}$ |
| Storage Temperature | T_{stg} | | | -40 to 125 | $^\circ\text{C}$ |
| Channel Junction Temperature | T_J | | | 150 | $^\circ\text{C}$ |

¹Refer to figure 1

²Refer to figure 3

³Refer to figure 5

⁴Mounted on 15 x 15 mm printed circuit board

⁵Refer to figure 6

⁶Measured at the root of terminal 3

Figure 1 – MOSFET Safe Operating Area Derating Curve

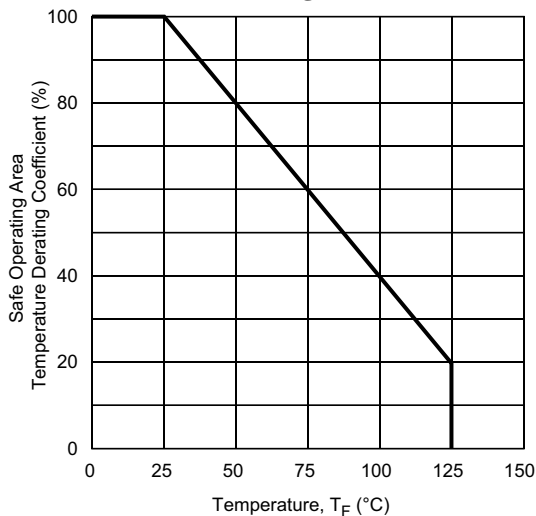
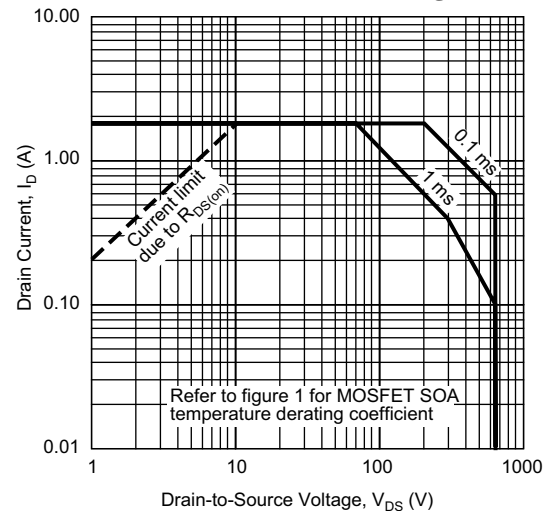

Figure 2 – MOSFET Safe Operating Area Drain Current versus Voltage



STR-A6259H
Universal Input 13 W 100 kHz
Flyback Switching Regulators

*Switching
Regulators*

Figure 3 – MOSFET Avalanche Energy Derating Curve

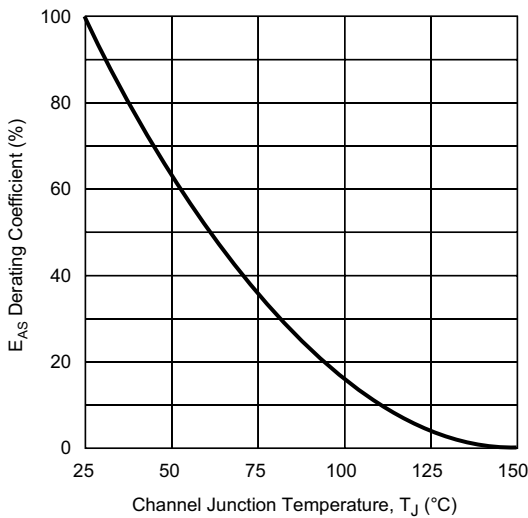

Figure 4 – Transient Thermal Resistance

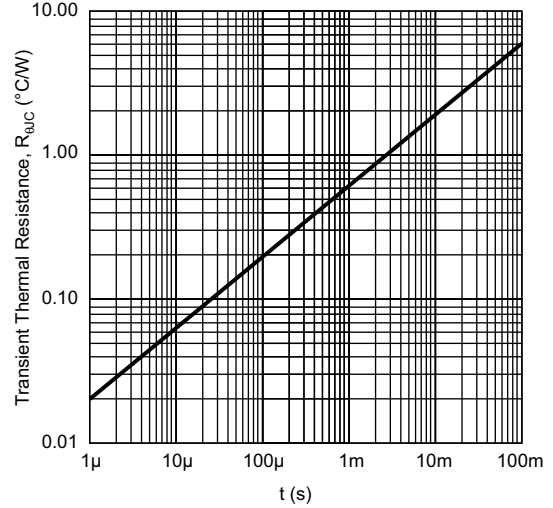

Figure 5 – MOSFET Power Dissipation versus Temperature

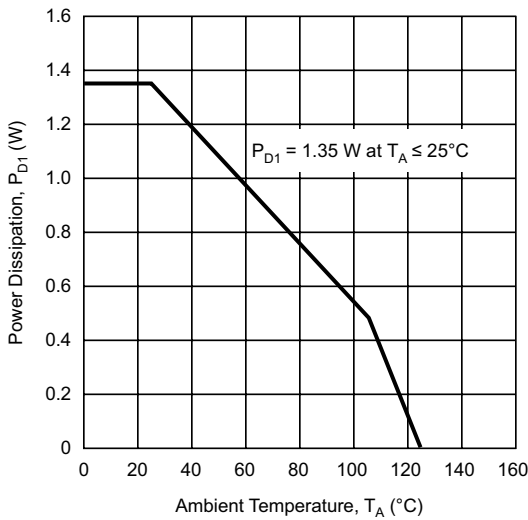
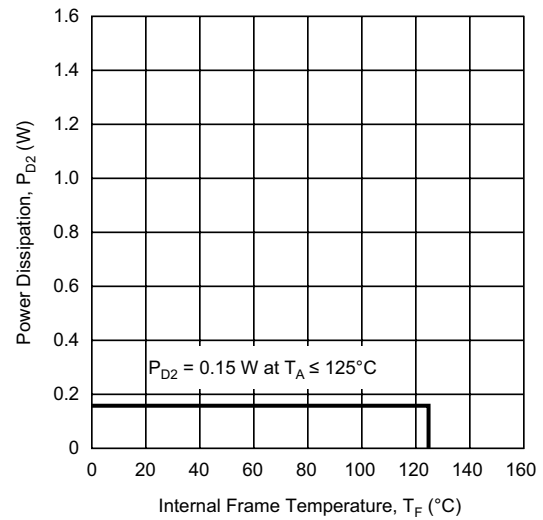

Figure 6 – MIC Power Dissipation versus Temperature



STR-A6259H

Universal Input 13 W 100 kHz

Flyback Switching Regulators

Switching
Regulators

ELECTRICAL CHARACTERISTICS for Controller (MIC), valid at $T_A = 25^\circ\text{C}$, $V_{CC} = 18\text{ V}$, unless otherwise specified

| Characteristic | Symbol | Terminal | Test Conditions | Min. | Typ. | Max. | Unit |
|------------------------------------|-----------------|----------|---|-------|------|------|---------------|
| Operation Start Voltage | $V_{CC(ON)}$ | 5-3 | (Power supply voltage at which device starts operating) Measurement circuit 1, $V_{CC} = 0$ though 13.1 to 16.1 V | 12.9 | 14.3 | 15.7 | V |
| Operation Stop Voltage | $V_{CC(OFF)}$ | 5-3 | (Power supply voltage at which device stops operating) Measurement circuit 1, $V_{CC} = 16.1$ through 9 to 11 V | 9 | 10 | 11 | V |
| Circuit Current In Operation | $I_{CC(ON)}$ | 5-3 | (Inflow current into power supply terminal, in operation) Measurement circuit 1 | – | – | 4 | mA |
| Initialization Circuit Current | $I_{CC(OFF)}$ | 5-3 | (Inflow current into power supply terminal, while subject to UVLO prior to operation) Measurement circuit 1, $V_{CC} = 13\text{ V}$ | – | – | 25 | μA |
| Center Switching Frequency | $f_{osc(av)}$ | 8-3 | (Center oscillation frequency of D terminal) Measurement circuit 2 | 90 | 100 | 110 | KHz |
| Frequency Jitter Deviation | Δf | 8-3 | Maximum frequency – minimum frequency Measurement circuit 2 | 6 | 10 | 14 | KHz |
| Maximum Duty Cycle | D_{MAX} | 8-3 | (Maximum width of the low portion of the D terminal waveform) Measurement circuit 2 | 70 | 76 | 82 | % |
| FM High Voltage | V_{HFM} | 2-3 | (V_{FM} at which the FM current is changed from 10 μA to –10 μA) Measurement circuit 2 | 4.0 | 4.5 | 5.0 | V |
| FM Low Voltage | V_{LFM} | 2-3 | (V_{FM} at which the FM current is changed from –10 μA to 10 μA) Measurement circuit 2 | 3.2 | 3.6 | 4.0 | V |
| FM Outflow Current | I_{sorcFM} | 2-3 | Outflow current from FM terminal at $V_{FM} = V_{LFM}$ (3.7 V typ.) Measurement circuit 2 | 7.7 | 11 | 15.4 | μA |
| FM Inflow Current | I_{sinkFM} | 2-3 | Inflow current into FM terminal at $V_{FM} = V_{HFM}$ (4.4 V typ.) Measurement circuit 2 | –15.4 | –11 | –7.7 | μA |
| OCP Threshold Voltage | $V_{OCP(th)}$ | 1-3 | (The drain current at which the low portion of the D terminal waveform becomes shorter than the high portion, with V_{OCP} increasing) Measurement circuit 3 | 0.67 | 0.74 | 0.81 | V |
| Leading Edge Blanking Time | t_{wb} | 8-3 | (The low portion of the D terminal waveform with $V_{OCP} = 1\text{ V}$) Measurement circuit 3 | 240 | 350 | 460 | ns |
| Burst Threshold Voltage | $V_{burst(th)}$ | 4-3 | (FB/CC/OLP terminal voltage at which D terminal waveform oscillation stops due to V_{FB} decreasing from 5 V) Measurement circuit 4 | 1.0 | 1.12 | 1.24 | V |
| OLP Threshold Voltage | $V_{OLP(th)}$ | 4-3 | (FB/CC/OLP terminal voltage at which D terminal waveform oscillation stops due to V_{FB} increasing from 5 V) Measurement circuit 4 | 7.3 | 8.6 | 9.9 | V |
| Output Current at OLP Operation | I_{OLP} | 4-3 | (Outflow current from FB/CC/OLP terminal at $V_{FB} = 8\text{ V}$) Measurement circuit 4 | 12 | 18 | 25 | μA |
| OLP Delay Time | T_{OLP} | 4-3 | (Time between surpassing $V_{OLP(th)}$ and stop of oscillation) Measurement circuit 4 | 0.84 | 1.2 | 1.56 | s |
| Maximum Feedback Current | $I_{FB(MAX)}$ | 4-3 | (Outflow current from FB/CC/OLP terminal at $V_{FB} = 0\text{ V}$) Measurement circuit 4 | 220 | 310 | 430 | μA |

Continued on next page...

STR-A6259H
Universal Input 13 W 100 kHz
Flyback Switching Regulators

Switching
Regulators

ELECTRICAL CHARACTERISTICS for Controller (MIC) continued, valid at $T_A = 25^\circ\text{C}$, $V_{CC} = 18\text{ V}$, unless otherwise specified

| | | | | | | | |
|---|-----------------|-----|--|------|-----|------|------------------|
| Constant Current Set Voltage | $V_{SET(CC)}$ | 4-3 | (FB/CC/OLP terminal voltage at which I_{FB} changes from 280 μA to 16 μA due to V_{FB} increasing from 5 V) Measurement circuit 4 | 4.9 | 5.8 | 6.7 | V |
| Constant Current Reset Voltage | $V_{RES(CC)}$ | 4-3 | (FB/CC/OLP terminal voltage at which I_{FB} changes from 16 μA to 280 μA due to V_{FB} decreasing from 8 V) $V_{RES(CC)} \times V_{CC} = 25\text{ V}$, Measurement circuit 4, $V_{CC} = 25\text{ V}$ | 3.5 | 3.9 | 4.3 | V |
| Start-Up Current | $I_{startup}$ | 6-3 | (Outflow current from V_{CC} terminal at $V_{DD} = 600\text{ V}$) Measurement circuit 5, $V_{CC} = 13\text{ V}$ | 0.77 | 1.1 | 1.43 | mA |
| OVP Threshold Voltage | $V_{CC(OVPth)}$ | 5-3 | (V_{CC} at which the oscillation of the D terminal waveform stops due to V_{CC} increasing from 18 V) Measurement circuit 1, $V_{CC} = 18$ through 31 to 35.2 V | 28.8 | 32 | 35.2 | V |
| Latch Circuit Sustaining Current ¹ | $I_{CC(H)}$ | 5-3 | (Inflow current into VCC at $V_{CC} = 8.4\text{ V}$, after OVP operation) Measurement circuit 1, $V_{CC} = 35.2$ to 8.6 V | – | – | 270 | μA |
| Latch Circuit Release Voltage ¹ | $V_{CC(LaOFF)}$ | 5-3 | (V_{CC} at which I_{CC} drops below 20 μA due to decreasing V_{CC} after OVP operation) Measurement circuit 1, $V_{CC} = 35.2$ through 5.9 to 8.6 V | 5.9 | 7.2 | 8.6 | V |
| Thermal Shutdown Operating Temperature | $T_{J(TSD)}$ | | | 125 | 140 | – | $^\circ\text{C}$ |

ELECTRICAL CHARACTERISTICS for MOSFET, valid at $T_A = 25^\circ\text{C}$, $V_{CC} = 18\text{ V}$, unless otherwise specified

| | | | | | | | |
|-----------------------------------|-------------------------|-----|---|-----|---|-----|--------------------|
| Drain-to-Source Breakdown Voltage | V_{DSS} | 8-1 | Measurement circuit 6, $I_D = 300\ \mu\text{A}$ | 650 | – | – | V |
| Drain Leakage Current | I_{DSS} | 8-1 | (Inflow current into D terminal at $V_{DD} = 650\text{ V}$) Measurement circuit 5 | – | – | 300 | μA |
| On-Resistance | $R_{DS(ON)}$ | 8-1 | Measurement circuit 3, $I_D = 0.4\text{ A}$ | – | – | 6 | Ω |
| Switching Time | t_f | 8-1 | Measurement circuit 2 | – | – | 250 | ns |
| Thermal Resistance | $R_{\theta\text{ch-F}}$ | | Between channel and internal frame; measured at the root of terminal 3 | – | – | 52 | $^\circ\text{C/W}$ |

¹Latch circuit enabled when OVP and TSD in operation

STR-A6259H

Universal Input 13 W 100 kHz

Flyback Switching Regulators

Switching
Regulators

Measurement Circuit 1

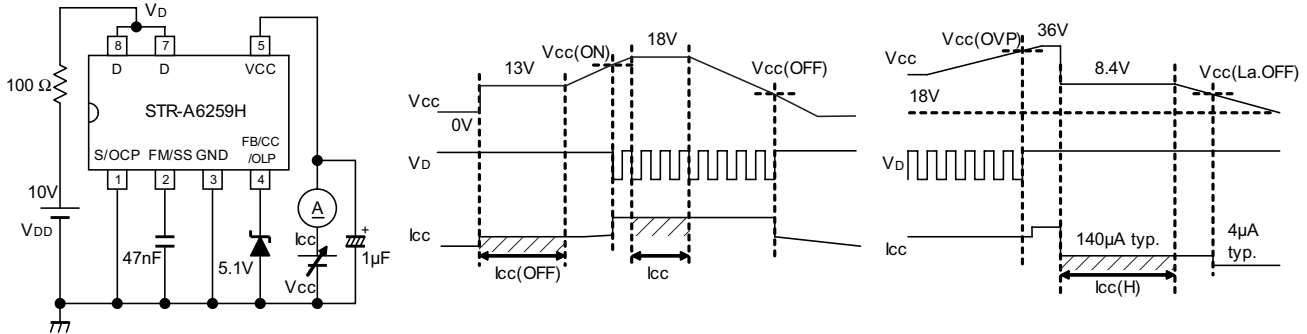

Measurement Circuit 2

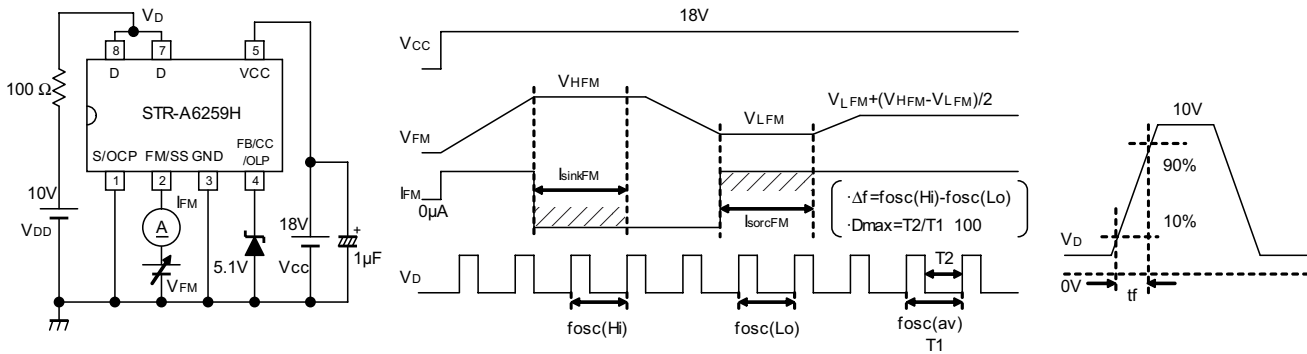

Measurement Circuit 3

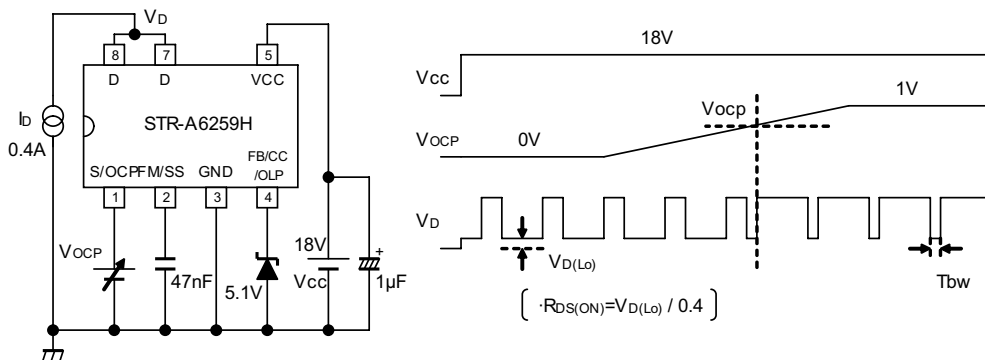

STR-A6259H

Universal Input 13 W 100kHz

Flyback Switching Regulators

Switching
Regulators

Measurement Circuit 4

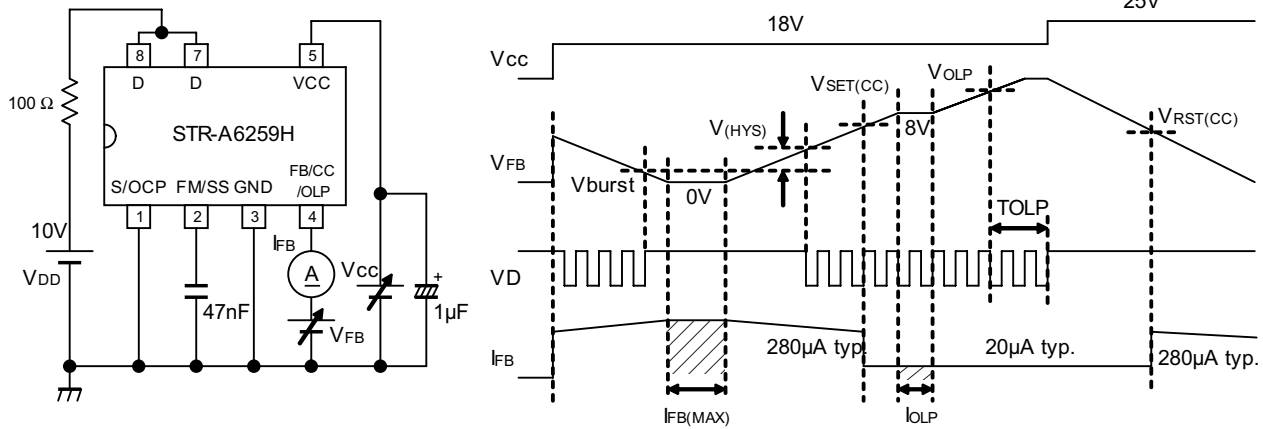

Measurement Circuit 5

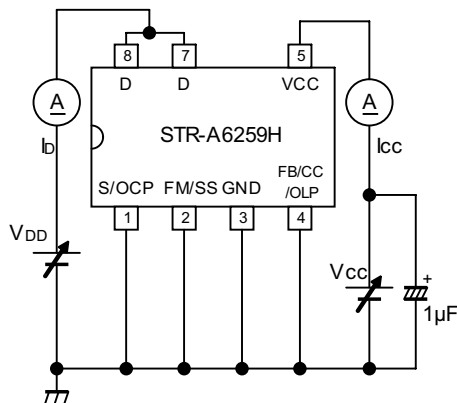

Measurement Circuit 6

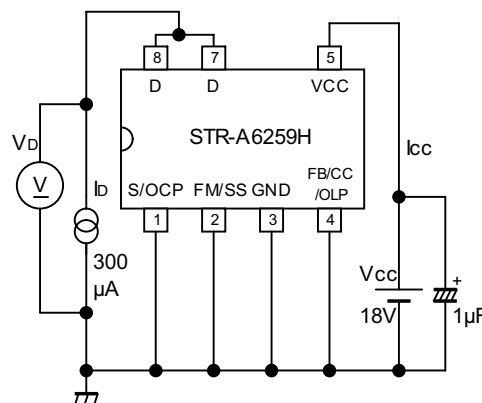

Measurement Circuit 7

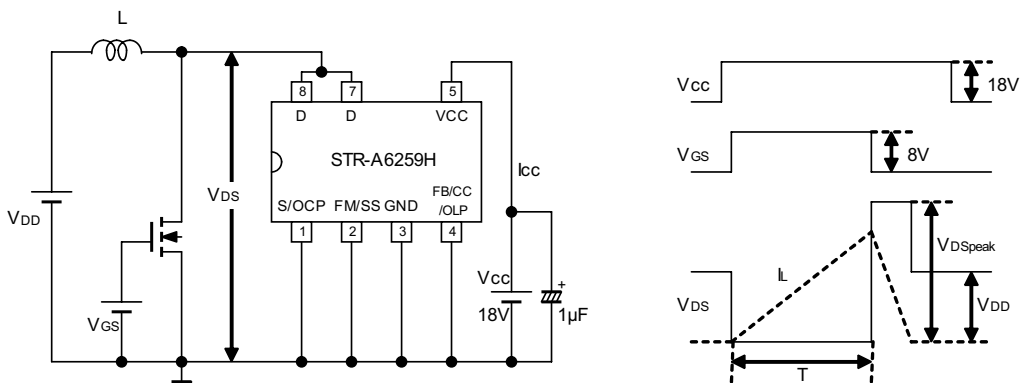

$$E_{AS} = \frac{L}{2} (I_{Lpeak})^2 \times \frac{V_{DSpeak}}{V_{DSpeak} - V_{DD}}$$

Adjust T such that $I_{Lpeak} = 1.8 A$

STR-A6259H
Universal Input 13 W 100 kHz
Flyback Switching Regulators

*Switching
Regulators*

TYPICAL APPLICATION CIRCUIT

For improved thermal dissipation, connect terminals 7 and 8 to as large an area of exposed copper as possible

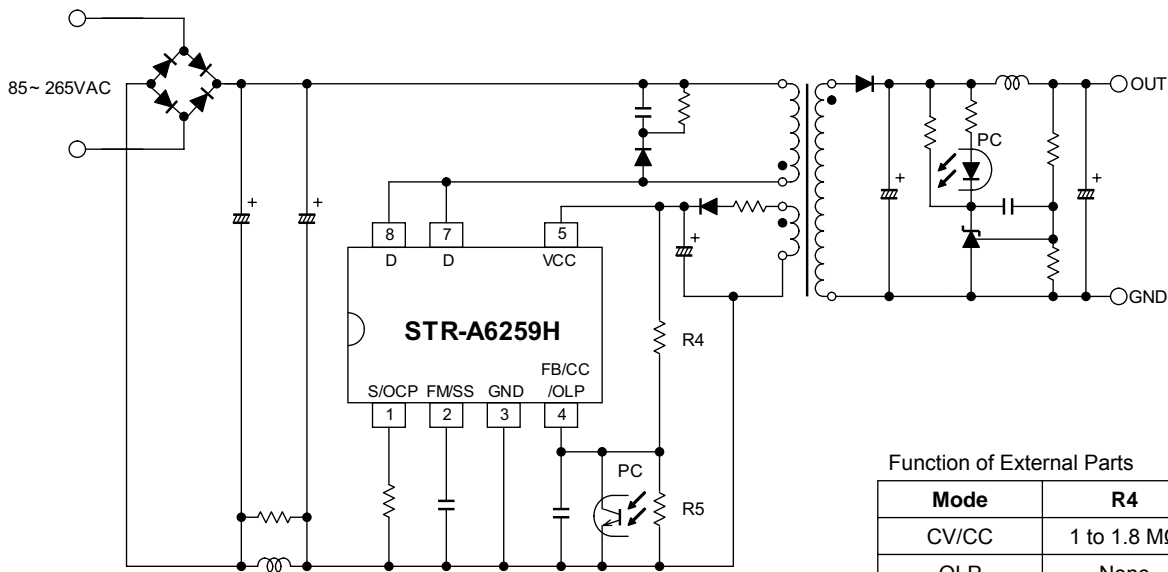

Function of External Parts

| Mode | R4 | R5 |
|-------|-------------|--------------|
| CV/CC | 1 to 1.8 MΩ | 82 to 150 kΩ |
| OLP | None | None |

STR-A6259H
Universal Input 13 W 100 kHz
Flyback Switching Regulators

*Switching
Regulators*

PACKAGE DIMENSIONS, DIP-8

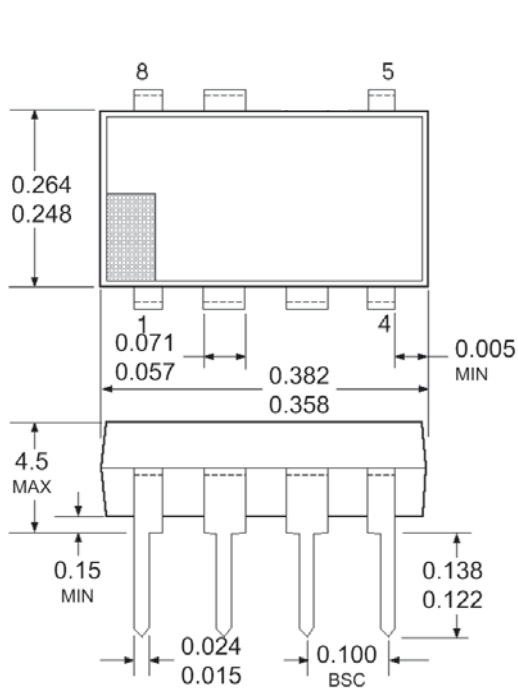

Dimensions in Inches
(for reference only)

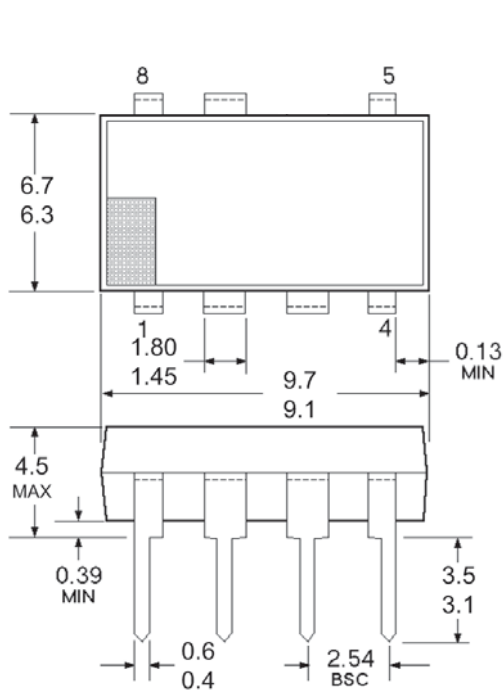

Dimensions in Millimeters
(controlling dimensions)

STR-A6259H
Universal Input 13 W 100kHz
Flyback Switching Regulators

*Switching
Regulators*

PACKING SPECIFICATIONS
Minimum packing option: Tubes

Orientation of Devices in Shipping Tubes

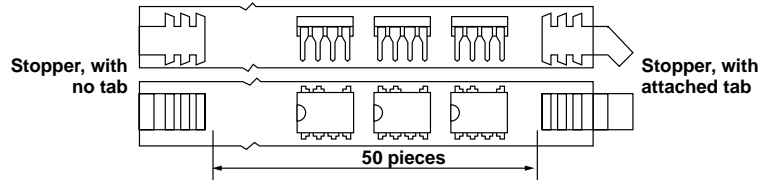

Shipping Tube Dimensions

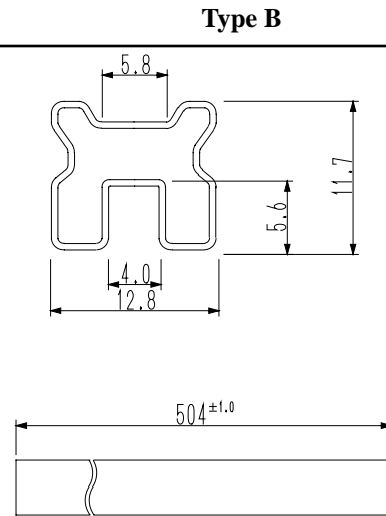
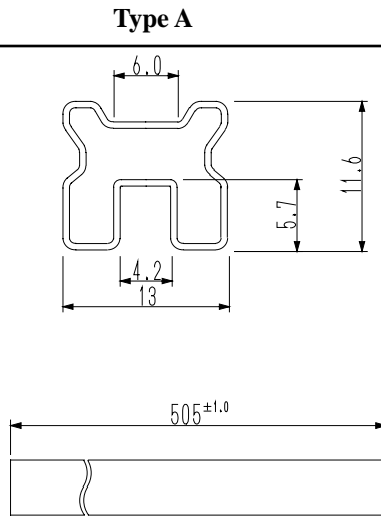

Inner Carton Dimensions
Capacity: 50 tubes per inner carton

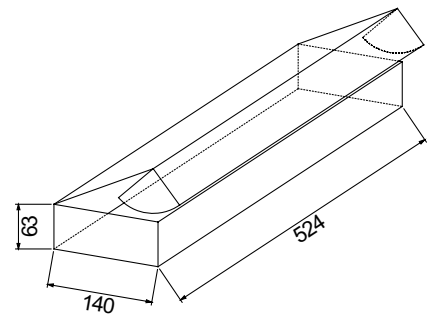
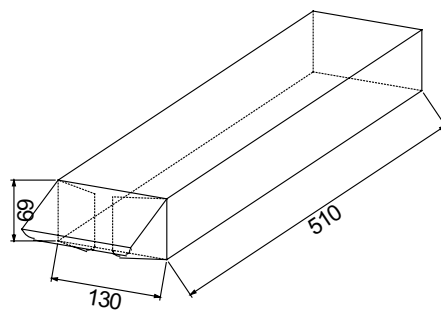

Outer Carton Dimensions
Capacity: 4 inner cartons per outer carton;
10,000 devices maximum per outer carton

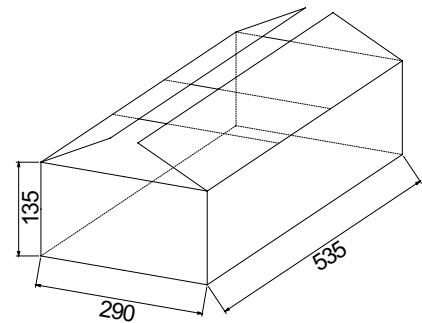
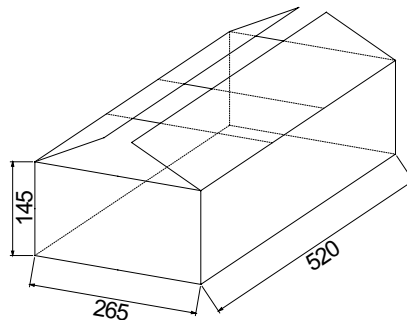

All dimensions: mm

STR-A6259H
Universal Input 13 W 100 kHz
Flyback Switching Regulators

*Switching
Regulators*

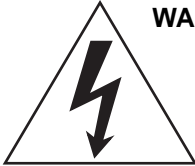

WARNING — These devices are designed to be operated at lethal voltages and energy levels. Circuit designs that embody these components must conform with applicable safety requirements. Precautions must be taken to prevent accidental contact with power-line potentials. Do not connect grounded test equipment.

The use of an isolation transformer is recommended during circuit development and breadboarding.

Because reliability can be affected adversely by improper storage environments and handling methods, please observe the following cautions.

Cautions for Storage

- Ensure that storage conditions comply with the standard temperature (5°C to 35°C) and the standard relative humidity (around 40 to 75%); avoid storage locations that experience extreme changes in temperature or humidity.
- Avoid locations where dust or harmful gases are present and avoid direct sunlight.
- Reinspect for rust in leads and solderability of products that have been stored for a long time.

Cautions for Testing and Handling

When tests are carried out during inspection testing and other standard test periods, protect the products from power surges from the testing device, shorts between adjacent products, and shorts to the heatsink.

Remarks About Using Silicone Grease with a Heatsink

- When silicone grease is used in mounting this product on a heatsink, it shall be applied evenly and thinly. If more silicone grease than required is applied, it may produce stress.
- Volatile-type silicone greases may produce cracks after long periods of time, resulting in reduced heat radiation effect. Silicone grease with low consistency (hard grease) may cause cracks in the mold resin when screwing the product to a heatsink.
- Our recommended silicone greases for heat radiation purposes, which will not cause any adverse effect on the product life, are indicated below:

| Type | Suppliers |
|--------|--------------------------------------|
| G746 | Shin-Etsu Chemical Co., Ltd. |
| YG6260 | Toshiba Silicone Co., Ltd. |
| SC102 | Dow Corning Toray Silicone Co., Ltd. |

Soldering

- When soldering the products, please be sure to minimize the working time, within the following limits:
 260±5°C 10 s
 350±5°C 3 s
- Soldering iron should be at a distance of at least 1.5 mm from the body of the products

Electrostatic Discharge

- When handling the products, operator must be grounded. Grounded wrist straps worn should have at least 1 MΩ of resistance to ground to prevent shock hazard.
- Workbenches where the products are handled should be grounded and be provided with conductive table and floor mats.
- When using measuring equipment such as a curve tracer, the equipment should be grounded.
- When soldering the products, the head of soldering irons or the solder bath must be grounded in order to prevent leak voltages generated by them from being applied to the products.
- The products should always be stored and transported in our shipping containers or conductive containers, or be wrapped in aluminum foil.

STR-A6259H
Universal Input 13 W 100 kHz
Flyback Switching Regulators

Switching
Regulators

The products described herein are manufactured in Japan by Sanken Electric Co., Ltd. for sale by Allegro MicroSystems, Inc.

Sanken and Allegro reserve the right to make, from time to time, such departures from the detail specifications as may be required to permit improvements in the performance, reliability, or manufacturability of its products. Therefore, the user is cautioned to verify that the information in this publication is current before placing any order.

When using the products described herein, the applicability and suitability of such products for the intended purpose shall be reviewed at the users responsibility.

Although Sanken undertakes to enhance the quality and reliability of its products, the occurrence of failure and defect of semiconductor products at a certain rate is inevitable.

Users of Sanken products are requested to take, at their own risk, preventative measures including safety design of the equipment or systems against any possible injury, death, fires or damages to society due to device failure or malfunction.

Sanken products listed in this publication are designed and intended for use as components in general-purpose electronic equipment or apparatus (home appliances, office equipment, telecommunication equipment, measuring equipment, etc.). Their use in any application requiring radiation hardness assurance (e.g., aerospace equipment) is not supported.

When considering the use of Sanken products in applications where higher reliability is required (transportation equipment and its control systems or equipment, fire- or burglar-alarm systems, various safety devices, etc.), contact a company sales representative to discuss and obtain written confirmation of your specifications.

The use of Sanken products without the written consent of Sanken in applications where extremely high reliability is required (aerospace equipment, nuclear power-control stations, life-support systems, etc.) is strictly prohibited.

The information included herein is believed to be accurate and reliable. Application and operation examples described in this publication are given for reference only and Sanken and Allegro assume no responsibility for any infringement of industrial property rights, intellectual property rights, or any other rights of Sanken or Allegro or any third party that may result from its use.

Copyright © 2006 Allegro MicroSystems, Inc.

This datasheet is based on Sanken datasheet SSE2366-2