



INT51X1

Single Chip PowerPacket™ Transceiver



Features

- Single-chip powerline networking transceiver with integrated MII, Ethernet and USB interfaces
- Integrated 10-bit ADC, 10-bit DAC and AGC control
- Single-supplier solution for powerline MAC/PHY and AFE
- Implements Intellon's patented PowerPacket technology
- HomePlug 1.0 compliant
- General purpose 8-wire serial PHY data interface
- Selectable MDI/SPI PHY management interface
- Up to 14 Mbps data rate on the powerline
- Low power consumption
- Orthogonal Frequency Division Multiplexing (OFDM) with patented signal processing techniques for high data reliability in noisy media conditions
- Intelligent channel adaptation maximizes throughput under harsh channel conditions
- Integrated Quality of Service (QoS) features: prioritized random access, contention-free access, and segment bursting

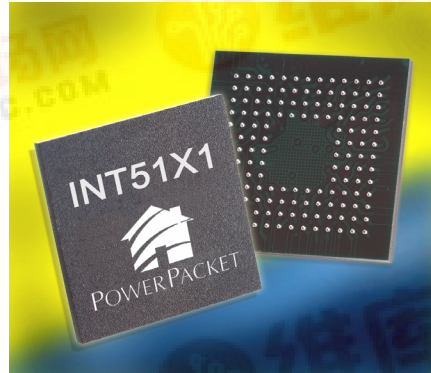

Benefits

The INT51X1 Integrated Powerline MAC/PHY Transceiver is the world's first all CMOS single chip integrating all of the digital and analog functions required in a *HomePlug 1.0* solution.

Housed in a dime-size micro-BGA package, it simplifies product designs, significantly reduces the bill of materials and assembly costs, and accelerates time to market.

Breakthrough integration provides three types of host interface for maximum system flexibility:

- A USB1.1 device interface for connection to a USB host
- An MII PHY (IEEE 802.3u) / GPSI interface for interconnection to microcontrollers or Ethernet controllers
- An MII Host / DTE interface (IEEE 802.3u) for direct connection to an Ethernet PHY

The INT51X1 is also the industry's first to integrate the analog front-end blocks: a 10-bit ADC, a 10-bit DAC and AGC control circuitry.

The INT51X1 implements Intellon's patented PowerPacket OFDM technology, which forms the basis for the *HomePlug 1.0.1 Specification*. Specifically tailored to reliably deliver up to 14 Mbps over the difficult power line communication environment, the IC combats deep attenuation notches, noises sources, and multi-path fading by allocating usable frequencies according to the signal to noise ratio (SNR). Synchronization is achieved in low SNR channels without the use of pilot carriers.

The MAC implements a CSMA/CA scheme with prioritization and automatic repeat request (ARQ) for reliable delivery of Ethernet packets via packet encapsulation. Built-in Quality of Service (QoS) features provide the necessary bandwidth for multimedia payloads including voice, data, audio, and video. A four-level prioritized random access method exists with strict adherence to priority. Segment bursting on the power line minimizes the demands on the receiver resources and maximizes the throughput of the network while still providing excellent latency response and jitter performance. The IC's contention-free access capability extends this concept of segment bursting to allow the transmission of multiple frames over the power line without relinquishing the control of the medium. Utilizing contention-free access, a single station may act as a controller for the entire network.



INT51X1 Single Chip PowerPacket Transceiver

- 56-bit DES Link Encryption with key management for secure powerline communications
- EEPROM interface for fast access to configuration parameters allows system designers to leverage standard Ethernet drivers
- IEEE 1149.1 JTAG Test Access Port
- 3.3V signaling, 5V tolerant I/Os
- 144-pin µBGA small footprint package



Intellon Corporation
5100 West Silver Springs Blvd.
Ocala, FL 34482
(352) 237-7416
(352) 237-7616 (Fax)

1762 Technology Dr., Ste 112
San Jose, CA 95110
(408) 501-0322
(408) 501-0323 (Fax)

www.intellon.com



System designers have the option of embedding PowerPacket-specific control information within the packet stream for optimal control and performance or choosing to provide this information via the separate EEPROM interface. Providing this configuration and control information through the EEPROM interface allows the system designer to leverage standard Ethernet drivers.

Intellon offers a complete solution for powerline communication applications using the INT51X1, including a suite of reference designs, data sheets, reference manuals, device driver source code and a production test system together with strong, proven technical support to shorten your time to market.

The INT51X1 is available for use in a wide range of settings, including residential (in-home), commercial (offices, apartments, hotels, warehouses), transportation and defense applications.

Just plug it in!

Functional Diagram

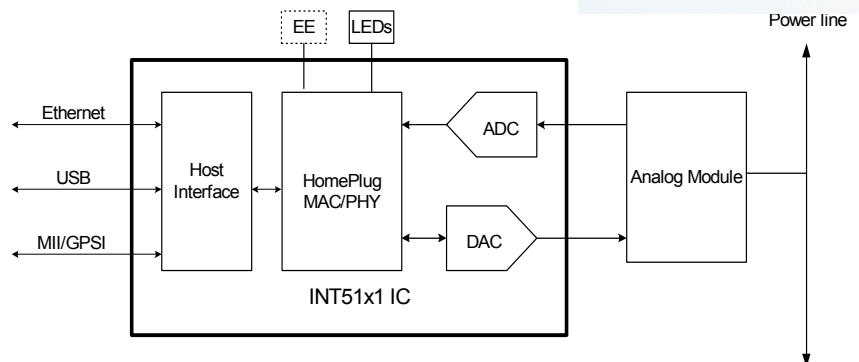

Target Applications

- Shared broadband internet access
- Audio and video streaming and transfer
- Expanding the coverage of wireless LANs
- Voice Over IP calls
- PC file and application sharing
- Printer and peripheral sharing
- Network and online gaming
- Security cameras

Intellon: The World Leader in Powerline Networking

- ✓ Patented technology chosen as the basis for HomePlug 1.0
- ✓ Complete HomePlug IC solution from a single supplier
- ✓ Only implementation proven in 500-home test
- ✓ Most real-world experience in Powerline networking