

TOSHIBA

TPS616

TOSHIBA PHOTO TRANSISTOR SILICON NPN EPITAXIAL PLANAR

TPS616

FLOPPY DISK DRIVE

VCR

POSITION DETECTOR OF HOME ELECTRIC EQUIPMENT

OPTO-ELECTRONIC SWITCH

- $\phi 3.1\text{mm}$ epoxy resin package. (black)
- Light current : $I_L = 10\mu\text{A}$ (MIN.) at $E = 0.1\text{mW}/\text{cm}^2$
- Half value angle : $\theta_{\frac{1}{2}} = \pm 30^\circ$ (TYP.)
- Protected from external light by black mold packaging.

MAXIMUM RATINGS ($T_a = 25^\circ\text{C}$)

CHARACTERISTIC	SYMBOL	RATING	UNIT
Collector-Emitter Voltage	V_{CEO}	30	V
Emitter-Collector Voltage	V_{ECO}	5	V
Collector Current	I_C	20	mA
Collector Power Dissipation	P_C	75	mW
Collector Power Dissipation Derating ($T_a > 25^\circ\text{C}$)	$\Delta P_C / ^\circ\text{C}$	-1	mW / $^\circ\text{C}$
Operating Temperature Range	T_{opr}	-30~85	$^\circ\text{C}$
Storage Temperature Range	T_{stg}	-30~100	$^\circ\text{C}$

Unit in mm

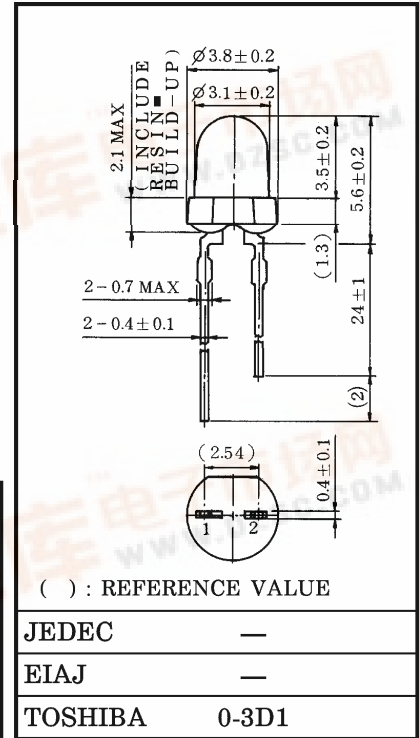

Weight : 0.12g (TYP.)

PIN CONNECTION

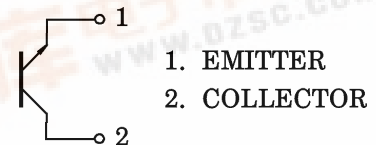

961001EAA2

● TOSHIBA is continually working to improve the quality and the reliability of its products. Nevertheless, semiconductor devices in general can malfunction or fail due to their inherent electrical sensitivity and vulnerability to physical stress. It is the responsibility of the buyer, when utilizing TOSHIBA products, to observe standards of safety, and to avoid situations in which a malfunction or failure of a TOSHIBA product could cause loss of human life, bodily injury or damage to property. In developing your designs, please ensure that TOSHIBA products are used within specified operating ranges as set forth in the most recent products specifications. Also, please keep in mind the precautions and conditions set forth in the TOSHIBA Semiconductor Reliability Handbook.

● The information contained herein is presented only as a guide for the applications of our products. No responsibility is assumed by TOSHIBA CORPORATION for any infringements of intellectual property or other rights of the third parties which may result from its use. No license is granted by implication or otherwise under any intellectual property or other rights of TOSHIBA CORPORATION or others.

● The information contained herein is subject to change without notice.

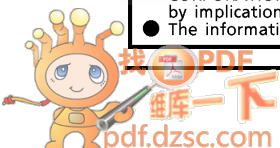

OPTO-ELECTRICAL CHARACTERISTICS (Ta = 25°C)

CHARACTERISTIC	SYMBOL	TEST CONDITION	MIN.	TYP.	MAX.	UNIT
Dark Current	$I_D (I_{CEO})$	$V_{CE} = 24V$	—	0.01	0.1	μA
Light Current	I_L (Note 2)	$V_{CE} = 3V, E = 0.1mW/cm^2$ (Note 1)	10	—	75	μA
Collector-Emitter Saturation Voltage	$V_{CE} (sat)$	$I_C = 5\mu A, E = 0.1mW/cm^2$ (Note 1)	—	0.2	0.4	V
Peak Sensitivity Wavelength	λ_P	—	—	900	—	nm
Half Vaule Angle	$\theta_{\frac{1}{2}}$	—	—	± 30	—	°
Switching Time	Rise time	$V_{CC} = 10V, I_C = 1mA$ $R_L = 1k\Omega$	—	9	—	μs
	Fall Time		—	10	—	

Note 1. Color temperature = 2870°K, Standard Tungsten Lamp.

Note 2. I_L Classification A : 10~25 μA , B : 17~42.5 μA , C : 30~75 μA ,
AB : 10~42.5 μA , BC : 17~75 μA

PRECAUTION

Please be careful of the followings.

- Soldering temperature : 260°C MAX. Soldering time : 3s MAX.
(Soldering portion of lead : above 1.5mm from the body of the device)
- If the lead is formed, the lead should be formed at a distance of 2mm from the body of the device.
Soldering shall be performed after lead forming.

Fig.1 SWITCHING TIME TEST CIRCUIT

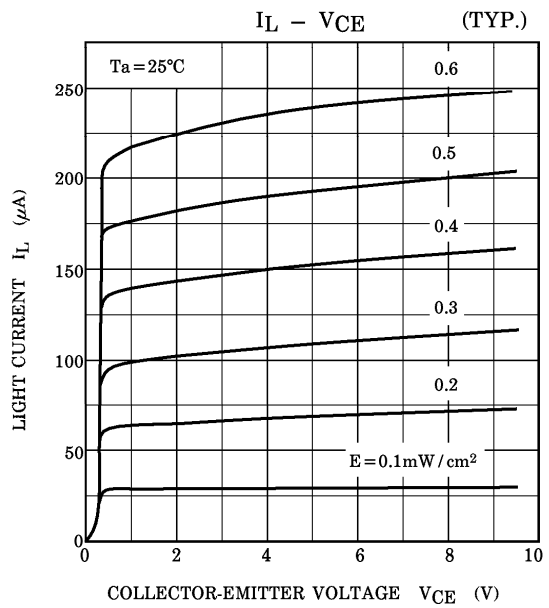
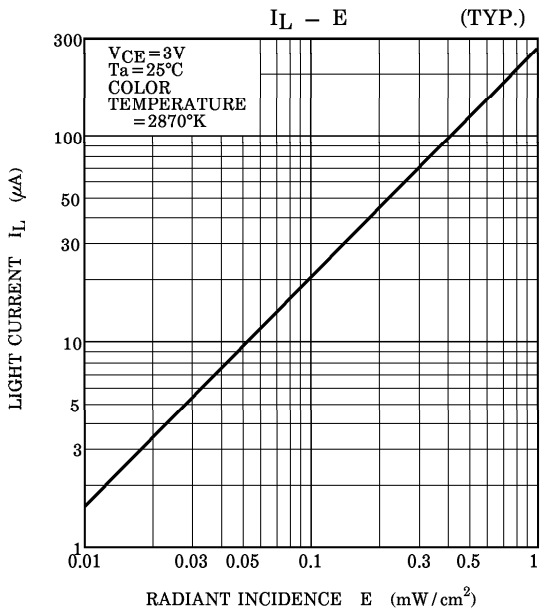
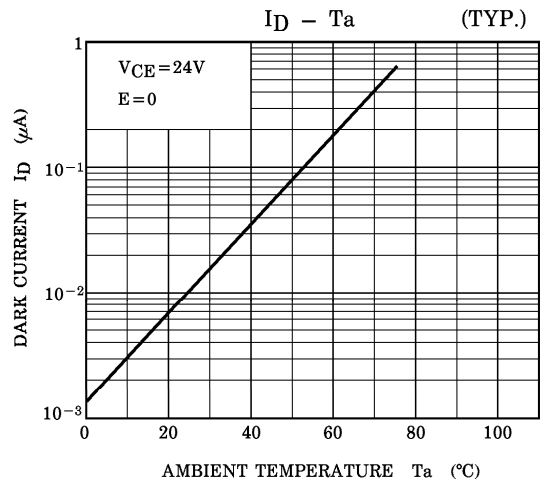
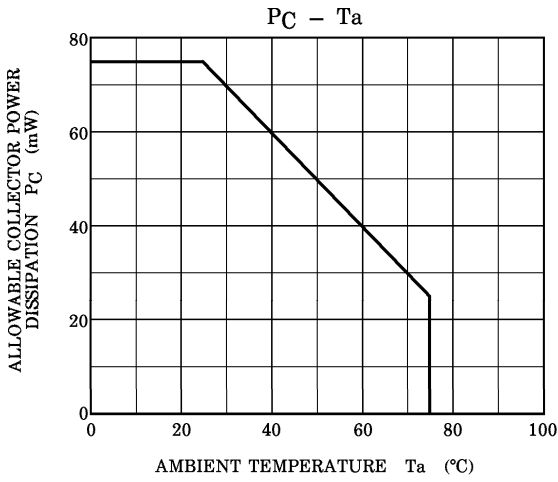
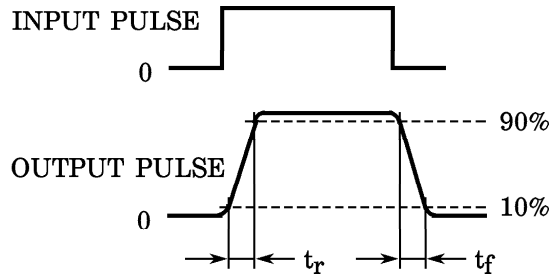
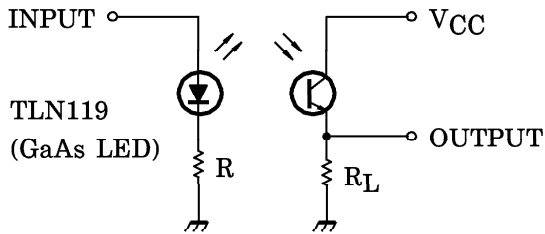

DIRECTIONAL SENSITIVITY CHARACTERISTIC (TYP.)
($T_a = 25^\circ\text{C}$)

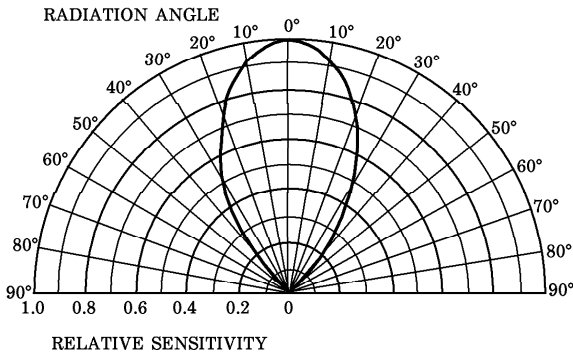

FREQUENCY CHARACTERISTICS (TYP.)

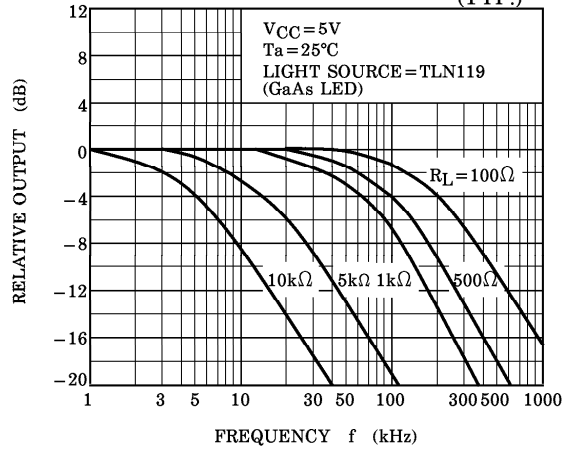

SWITCHING CHARACTERISTICS (TYP.)

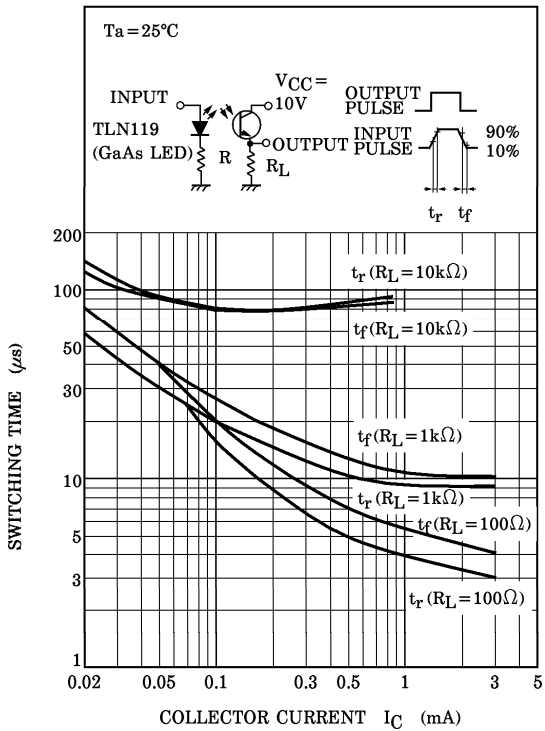

COUPLING CHARACTERISTICS WITH TLN119

