



MOTOROLA

Low Power, Single Supply Operational Amplifiers

Quality bipolar fabrication with innovative design concepts are employed for the MC33171/72/74 series of monolithic operational amplifiers. These devices operate at 180 μ A per amplifier and offer 1.8 MHz of gain bandwidth product and 2.1 V/ μ s slew rate without the use of JFET device technology. Although this series can be operated from split supplies, it is particularly suited for single supply operation, since the common mode input voltage includes ground potential (V_{EE}). With a Darlington input stage, these devices exhibit high input resistance, low input offset voltage and high gain. The all NPN output stage, characterized by no deadband crossover distortion and large output voltage swing, provides high capacitance drive capability, excellent phase and gain margins, low open loop high frequency output impedance and symmetrical source/sink AC frequency response.

The MC33171/72/74 are specified over the industrial/ automotive temperature ranges. The complete series of single, dual and quad operational amplifiers are available in plastic as well as the surface mount packages.

- Low Supply Current: 180 μ A (Per Amplifier)
- Wide Supply Operating Range: 3.0 V to 44 V or ± 1.5 V to ± 22 V
- Wide Input Common Mode Range, Including Ground (V_{EE})
- Wide Bandwidth: 1.8 MHz
- High Slew Rate: 2.1 V/ μ s
- Low Input Offset Voltage: 2.0 mV
- Large Output Voltage Swing: -14.2 V to $+14.2$ V (with ± 15 V Supplies)
- Large Capacitance Drive Capability: 0 pF to 500 pF
- Low Total Harmonic Distortion: 0.03%
- Excellent Phase Margin: 60°C
- Excellent Gain Margin: 15 dB
- Output Short Circuit Protection
- ESD Diodes Provide Input Protection for Dual and Quad

MC33171 MC33172 MC33174

DUAL

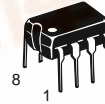

P SUFFIX
PLASTIC PACKAGE
CASE 626



D SUFFIX
PLASTIC PACKAGE
CASE 751
(SO-8)

PIN CONNECTIONS

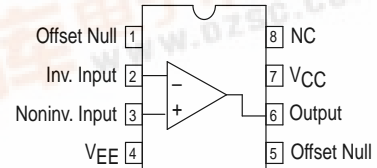

(Single, Top View)

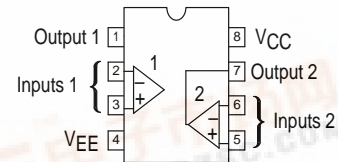

(Top View)

QUAD

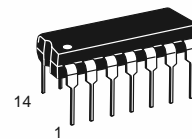

P SUFFIX
PLASTIC PACKAGE
CASE 646

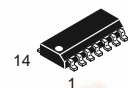

D SUFFIX
PLASTIC PACKAGE
CASE 751A
(SO-14)

PIN CONNECTIONS

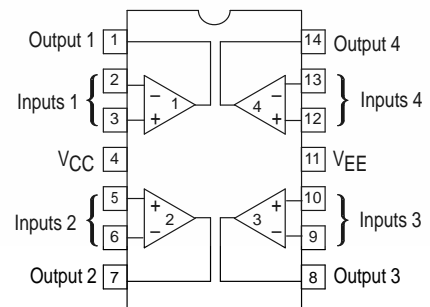

(Top View)

ORDERING INFORMATION

Op Amp Function	Device	Operating Temperature Range	Package
Single	MC33171D MC33171P	$T_A = -40^\circ$ to $+85^\circ\text{C}$ $T_A = -40^\circ$ to $+85^\circ\text{C}$	SO-8 Plastic DIP
Dual	MC33172D MC33172P	$T_A = -40^\circ$ to $+85^\circ\text{C}$ $T_A = -40^\circ$ to $+85^\circ\text{C}$	SO-8 Plastic DIP
Quad	MC33174D MC33174P	$T_A = -40^\circ$ to $+85^\circ\text{C}$ $T_A = -40^\circ$ to $+85^\circ\text{C}$	SO-14 Plastic DIP



MC33171 MC33172 MC33174

MAXIMUM RATINGS

Rating	Symbol	Value	Unit
Supply Voltage	V_{CC}/V_{EE}	± 22	V
Input Differential Voltage Range	V_{IDR}	(Note 1)	V
Input Voltage Range	V_{IR}	(Note 1)	V
Output Short Circuit Duration (Note 2)	t_{SC}	Indefinite	sec
Operating Ambient Temperature Range	T_A	-40 to +85	$^{\circ}\text{C}$
Operating Junction Temperature	T_J	+150	$^{\circ}\text{C}$
Storage Temperature Range	T_{stg}	-65 to +150	$^{\circ}\text{C}$

NOTES: 1. Either or both input voltages must not exceed the magnitude of V_{CC} or V_{EE} .
 2. Power dissipation must be considered to ensure maximum junction temperature (T_J) is not exceeded.

Representative Schematic Diagram
 (Each Amplifier)

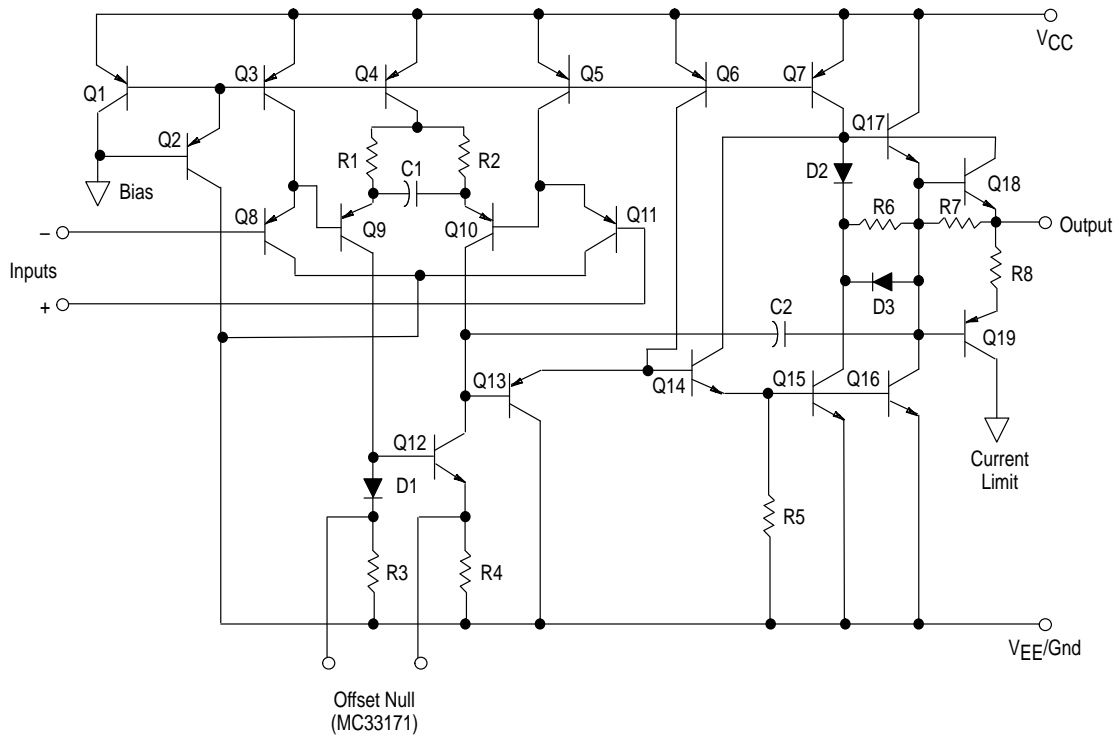

MC33171 MC33172 MC33174

DC ELECTRICAL CHARACTERISTICS ($V_{CC} = +15\text{ V}$, $V_{EE} = -15\text{ V}$, R_L connected to ground, $T_A = T_{low}$ to T_{high} [Note 3], unless otherwise noted.)

Characteristics	Symbol	Min	Typ	Max	Unit
Input Offset Voltage ($V_{CM} = 0\text{ V}$) $V_{CC} = +15\text{ V}$, $V_{EE} = -15\text{ V}$, $T_A = +25^\circ\text{C}$ $V_{CC} = +5.0\text{ V}$, $V_{EE} = 0\text{ V}$, $T_A = +25^\circ\text{C}$ $V_{CC} = +15\text{ V}$, $V_{EE} = -15\text{ V}$, $T_A = T_{low}$ to T_{high}	V_{IO}	— — —	2.0 2.5 —	4.5 5.0 6.5	mV
Average Temperature Coefficient of Offset Voltage	$\Delta V_{IO}/\Delta T$	—	10	—	$\mu\text{V}/^\circ\text{C}$
Input Bias Current ($V_{CM} = 0\text{ V}$) $T_A = +25^\circ\text{C}$ $T_A = T_{low}$ to T_{high}	I_{IB}	— —	20 —	100 200	nA
Input Offset Current ($V_{CM} = 0\text{ V}$) $T_A = +25^\circ\text{C}$ $T_A = T_{low}$ to T_{high}	I_{IO}	— —	5.0 —	20 40	nA
Large Signal Voltage Gain ($V_O = \pm 10\text{ V}$, $R_L = 10\text{ k}$) $T_A = +25^\circ\text{C}$ $T_A = T_{low}$ to T_{high}	A_{VOL}	50 25	500 —	— —	V/mV
Output Voltage Swing $V_{CC} = +5.0\text{ V}$, $V_{EE} = 0\text{ V}$, $R_L = 10\text{ k}$, $T_A = +25^\circ\text{C}$ $V_{CC} = +15\text{ V}$, $V_{EE} = -15\text{ V}$, $R_L = 10\text{ k}$, $T_A = +25^\circ\text{C}$ $V_{CC} = +15\text{ V}$, $V_{EE} = -15\text{ V}$, $R_L = 10\text{ k}$, $T_A = T_{low}$ to T_{high}	V_{OH}	3.5 13.6 13.3	4.3 14.2 —	— — —	V
	V_{OL}	— — —	0.05 -14.2 —	0.15 -13.6 -13.3	
Output Short Circuit ($T_A = +25^\circ\text{C}$) Input Overdrive = 1.0 V, Output to Ground Source Sink	I_{SC}	3.0 15	5.0 27	— —	mA
Input Common Mode Voltage Range $T_A = +25^\circ\text{C}$ $T_A = T_{low}$ to T_{high}	V_{ICR}	V_{EE} to $(V_{CC} - 1.8)$ V_{EE} to $(V_{CC} - 2.2)$			V
Common Mode Rejection Ratio ($R_S \leq 10\text{ k}$) $T_A = +25^\circ\text{C}$	CMRR	80	90	—	dB
Power Supply Rejection Ratio ($R_S = 100\ \Omega$) $T_A = +25^\circ\text{C}$	PSRR	80	100	—	dB
Power Supply Current (Per Amplifier) $V_{CC} = +5.0\text{ V}$, $V_{EE} = 0\text{ V}$, $T_A = +25^\circ\text{C}$ $V_{CC} = +15\text{ V}$, $V_{EE} = -15\text{ V}$, $T_A = +25^\circ\text{C}$ $V_{CC} = +15\text{ V}$, $V_{EE} = -15\text{ V}$, $T_A = T_{low}$ to T_{high}	I_D	— — —	180 220 —	250 250 300	μA

NOTE: 3. $T_{low} = -40^\circ\text{C}$ $T_{high} = +85^\circ\text{C}$

MC33171 MC33172 MC33174

AC ELECTRICAL CHARACTERISTICS ($V_{CC} = +15\text{ V}$, $V_{EE} = -15\text{ V}$, R_L connected to ground, $T_A = +25^\circ\text{C}$, unless otherwise noted.)

Characteristics	Symbol	Min	Typ	Max	Unit
Slew Rate ($V_{in} = -10\text{ V to } +10\text{ V}$, $R_L = 10\text{ k}$, $C_L = 100\text{ pF}$) $A_V +1$ $A_V -1$	SR	1.6 —	2.1 2.1	— —	V/ μs
Gain Bandwidth Product ($f = 100\text{ kHz}$)	GBW	1.4	1.8	—	MHz
Power Bandwidth $A_V = +1.0$, $R_L = 10\text{ k}$, $V_O = 20\text{ V}_{pp}$, THD = 5%	BWp	—	35	—	kHz
Phase Margin $R_L = 10\text{ k}$ $R_L = 10\text{ k}$, $C_L = 100\text{ pF}$	ϕ_m	— —	60 45	— —	Degree s
Gain Margin $R_L = 10\text{ k}$ $R_L = 10\text{ k}$, $C_L = 100\text{ pF}$	A_m	— —	15 5.0	— —	dB
Equivalent Input Noise Voltage $R_S = 100\ \Omega$, $f = 1.0\text{ kHz}$	e_n	—	32	—	nV/ $\sqrt{\text{Hz}}$
Equivalent Input Noise Current ($f = 1.0\text{ kHz}$)	I_n	—	0.2	—	pA/ $\sqrt{\text{Hz}}$
Differential Input Resistance $V_{cm} = 0\text{ V}$	R_{in}	—	300	—	M Ω
Input Capacitance	C_i	—	0.8	—	pF
Total Harmonic Distortion $A_V = +10$, $R_L = 10\text{ k}$, $2.0\text{ V}_{pp} \leq V_O \leq 20\text{ V}_{pp}$, $f = 10\text{ kHz}$	THD	—	0.03	—	%
Channel Separation ($f = 10\text{ kHz}$)	CS	—	120	—	dB
Open Loop Output Impedance ($f = 1.0\text{ MHz}$)	z_o	—	100	—	Ω

Figure 1. Input Common Mode Voltage Range versus Temperature

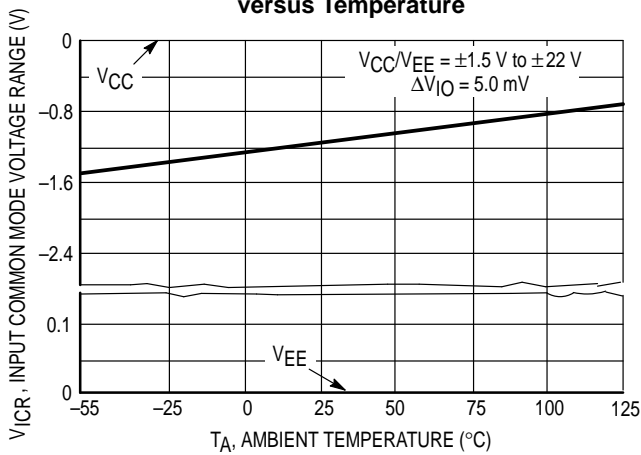
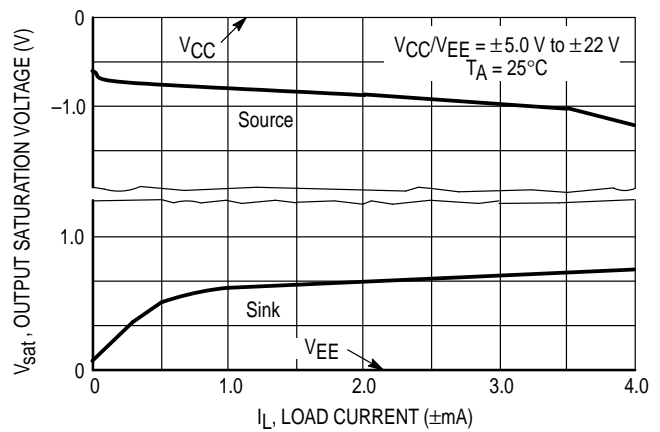

Figure 2. Split Supply Output Saturation versus Load Current



MC33171 MC33172 MC33174

Figure 3. Open Loop Voltage Gain and Phase versus Frequency

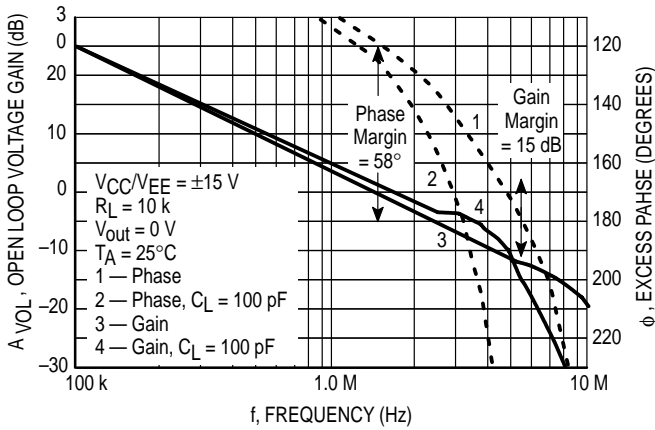

Figure 4. Phase Margin and Percent Overshoot versus Load Capacitance

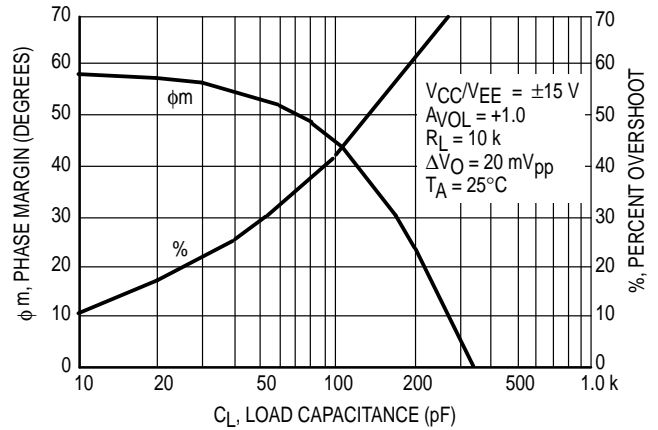

Figure 5. Normalized Gain Bandwidth Product and Slew Rate versus Temperature

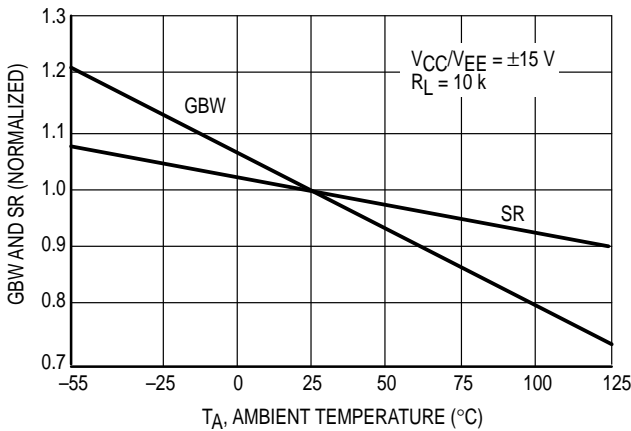

Figure 6. Small and Large Signal Transient Response

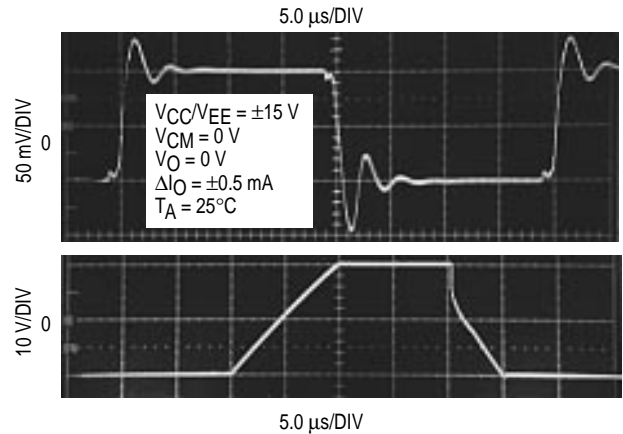

Figure 7. Output Impedance and Frequency

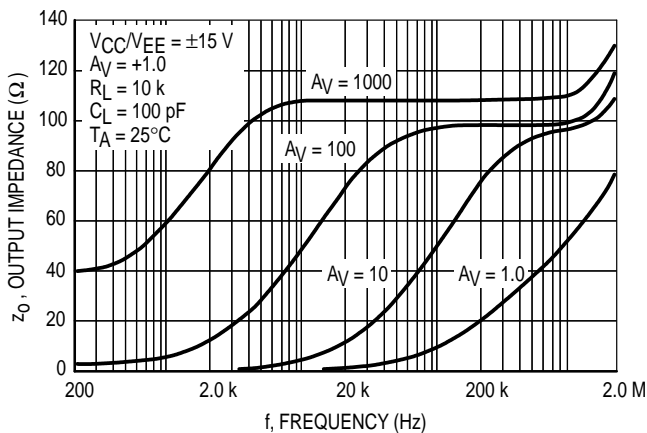
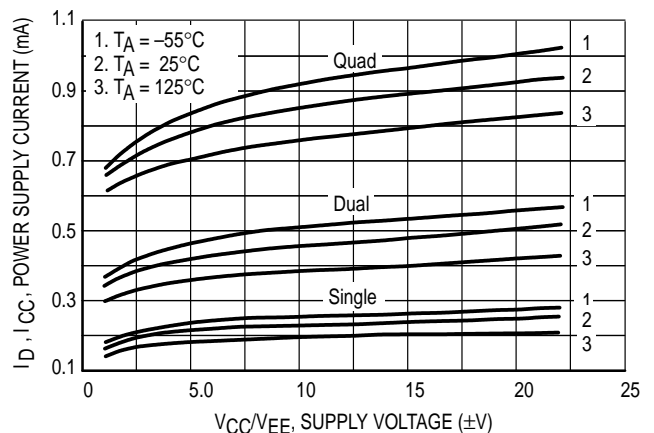

Figure 8. Supply Current versus Supply Voltage



MC33171 MC33172 MC33174

APPLICATIONS INFORMATION – CIRCUIT DESCRIPTION/PERFORMANCE FEATURES

Although the bandwidth, slew rate, and settling time of the MC33171/72/74 amplifier family is similar to low power op amp products utilizing JFET input devices, these amplifiers offer additional advantages as a result of the PNP transistor differential inputs and an all NPN transistor output stage.

Because the input common mode voltage range of this input stage includes the V_{EE} potential, single supply operation is feasible to as low as 3.0 V with the common mode input voltage at ground potential.

The input stage also allows differential input voltages up to ± 44 V, provided the maximum input voltage range is not exceeded. Specifically, the input voltages must range between V_{CC} and V_{EE} supply voltages as shown by the maximum rating table. In practice, although *not recommended*, the input voltages can exceed the V_{CC} voltage by approximately 3.0 V and decrease below the V_{EE} voltage by 0.3 V without causing product damage, although output phase reversal may occur. It is also possible to source up to 5.0 mA of current from V_{EE} through either inputs' clamping diode without damage or latching, but phase reversal may again occur. If at least one input is within the common mode input voltage range and the other input is within the maximum input voltage range, no phase reversal will occur. If both inputs exceed the upper common mode input voltage limit, the output will be forced to its lowest voltage state.

Since the input capacitance associated with the small geometry input device is substantially lower (0.8 pF) than that of a typical JFET (3.0 pF), the frequency response for a given input source resistance is greatly enhanced. This becomes evident in D-to-A current to voltage conversion applications where the feedback resistance can form a pole with the input capacitance of the op amp. This input pole creates a 2nd Order system with the single pole op amp and is therefore detrimental to its settling time. In this context, lower input capacitance is desirable especially for higher values of feedback resistances (lower current DACs). This input pole can be compensated for by creating a feedback zero with a capacitance across the feedback resistance, if necessary, to reduce overshoot. For 10 k Ω of feedback resistance, the MC33171/72/74 family can typically settle to within 1/2 LSB of 8 bits in 4.2 μ s, and within 1/2 LSB of 12 bits in 4.8 μ s for a 10 V step. In a standard inverting unity gain fast settling configuration, the symmetrical slew rate is typically ± 2.1 V/ μ s. In the classic noninverting unity gain configuration the typical output positive slew rate is also 2.1 V/ μ s, and the corresponding negative slew rate will usually exceed the positive slew rate as a function of the fall time of the input waveform.

The all NPN output stage, shown in its basic form on the equivalent circuit schematic, offers unique advantages over the more conventional NPN/PNP transistor Class AB output stage. A 10 k Ω load resistance can typically swing within 0.8 V of the positive rail (V_{CC}) and negative rail (V_{EE}), providing a 28.4 V_{pp} swing from ± 15 V supplies. This large output swing becomes most noticeable at lower supply voltages.

The positive swing is limited by the saturation voltage of the current source transistor Q7, the V_{BE} of the NPN pull-up transistor Q17, and the voltage drop associated with the short circuit resistance, R5. For sink currents less than 0.4 mA, the negative swing is limited by the saturation voltage of the pull-down transistor Q15, and the voltage drop across R4 and R5. For small valued sink currents, the above voltage drops are negligible, allowing the negative swing

voltage to approach within millivolts of V_{EE} . For sink currents (> 0.4 mA), diode D3 clamps the voltage across R4. Thus the negative swing is limited by the saturation voltage of Q15, plus the forward diode drop of D3 ($\approx V_{EE} + 1.0$ V). Therefore an unprecedented peak-to-peak output voltage swing is possible for a given supply voltage as indicated by the output swing specifications.

If the load resistance is referenced to V_{CC} instead of ground for single supply applications, the maximum possible output swing can be achieved for a given supply voltage. For light load currents, the load resistance will pull the output to V_{CC} during the positive swing and the output will pull the load resistance near ground during the negative swing. The load resistance value should be much less than that of the feedback resistance to maximize pull-up capability.

Because the PNP output emitter-follower transistor has been eliminated, the MC33171/72/74 family offers a 15 mA minimum current sink capability, typically to an output voltage of ($V_{EE} + 1.8$ V). In single supply applications the output can directly source or sink base current from a common emitter NPN transistor for current switching applications.

In addition, the all NPN transistor output stage is inherently faster than PNP types, contributing to the bipolar amplifier's improved gain bandwidth product. The associated high frequency low output impedance (200 Ω typ @ 1.0 MHz) allows capacitive drive capability from 0 pF to 400 pF without oscillation in the noninverting unity gain configuration. The 60°C phase margin and 15 dB gain margin, as well as the general gain and phase characteristics, are virtually independent of the source/sink output swing conditions. This allows easier system phase compensation, since output swing will not be a phase consideration. The AC characteristics of the MC33171/72/74 family also allow excellent active filter capability, especially for low voltage single supply applications.

Although the single supply specification is defined at 5.0 V, these amplifiers are functional to at least 3.0 V @ 25°C. However slight changes in parametrics such as bandwidth, slew rate, and DC gain may occur.

If power to this integrated circuit is applied in reverse polarity, or if the IC is installed backwards in a socket, large unlimited current surges will occur through the device that may result in device destruction.

As usual with most high frequency amplifiers, proper lead dress, component placement and PC board layout should be exercised for optimum frequency performance. For example, long unshielded input or output leads may result in unwanted input/output coupling. In order to preserve the relatively low input capacitance associated with these amplifiers, resistors connected to the inputs should be immediately adjacent to the input pin to minimize additional stray input capacitance. This not only minimizes the input pole for optimum frequency response, but also minimizes extraneous "pick up" at this node. Supply decoupling with adequate capacitance immediately adjacent to the supply pin is also important, particularly over temperature, since many types of decoupling capacitors exhibit great impedance changes over temperature.

The output of any one amplifier is current limited and thus protected from a direct short to ground. However, under such conditions, it is important not to allow the device to exceed the maximum junction temperature rating. Typically for ± 15 V supplies, any one output can be shorted continuously to ground without exceeding the maximum temperature rating.

MC33171 MC33172 MC33174

Figure 9. AC Coupled Noninverting Amplifier with Single +5.0 V Supply

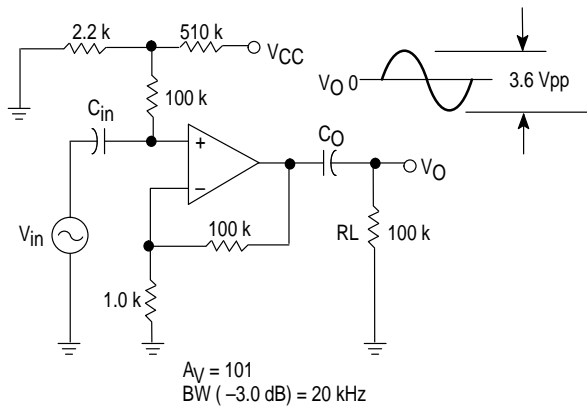

Figure 10. AC Coupled Inverting Amplifier with Single +5.0 V Supply

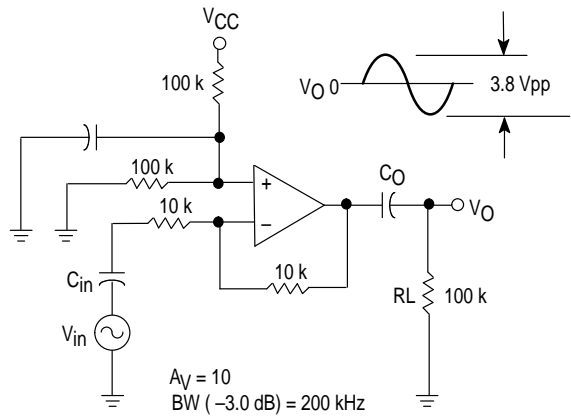

Figure 11. DC Coupled Inverting Amplifier Maximum Output Swing with Single +5.0 V Supply

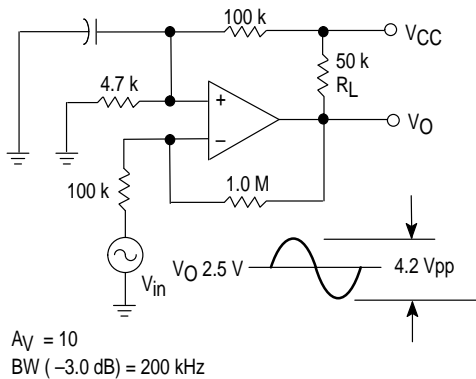
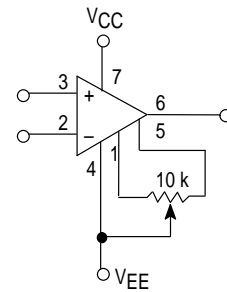

Figure 12. Offset Nulling Circuit



Offset Nulling range is approximately $\pm 80 \text{ mV}$ with a 10 k potentiometer, MC33171 only.

Figure 13. Active High-Q Notch Filter

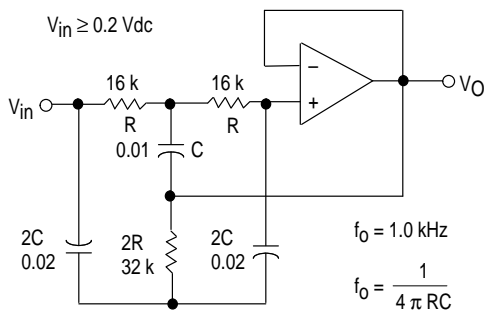
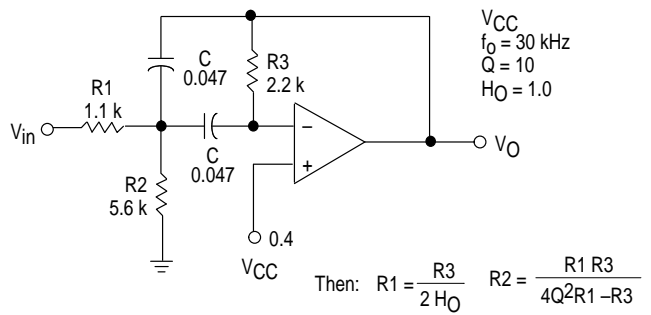

Figure 14. Active Bandpass Filter



Given f_0 = center frequency
 A_0 = Gain at center frequency
 Choose Value f_0 , Q , A_0 , C
 For less than 10% error for operational amplifier, where f_0 and GBW are expressed in Hz.

$R_3 = \frac{Q}{\pi f_0 C}$ $\frac{Q_0 f_0}{GBW} < 0.1$

MC33171 MC33172 MC33174

OUTLINE DIMENSIONS

P SUFFIX PLASTIC PACKAGE CASE 626-05 ISSUE K

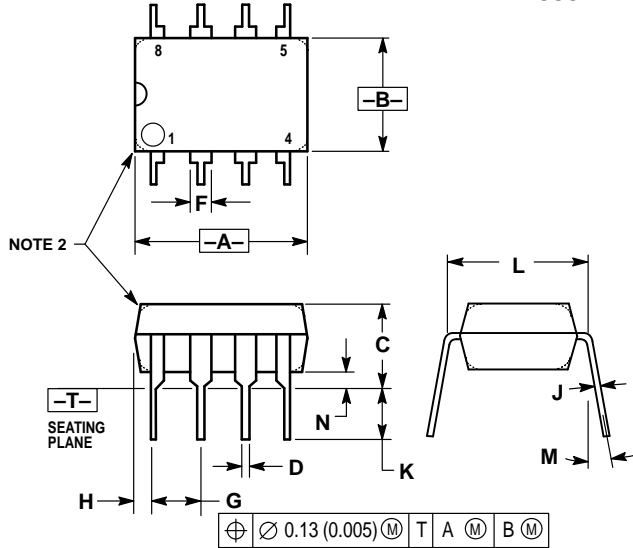

NOTES:

1. DIMENSION L TO CENTER OF LEAD WHEN FORMED PARALLEL.
2. PACKAGE CONTOUR OPTIONAL (ROUND OR SQUARE CORNERS).
3. DIMENSIONING AND TOLERANCING PER ANSI Y14.5M, 1982.

DIM	MILLIMETERS		INCHES	
	MIN	MAX	MIN	MAX
A	9.40	10.16	0.370	0.400
B	6.10	6.60	0.240	0.260
C	3.94	4.45	0.155	0.175
D	0.38	0.51	0.015	0.020
F	1.02	1.78	0.040	0.070
G	2.54 BSC		0.100 BSC	
H	0.76	1.27	0.030	0.050
J	0.20	0.30	0.008	0.012
K	2.92	3.43	0.115	0.135
L	7.62 BSC		0.300 BSC	
M	—	10°	—	10°
N	0.76	1.01	0.030	0.040

D SUFFIX PLASTIC PACKAGE CASE 751-05 (SO-8) ISSUE R

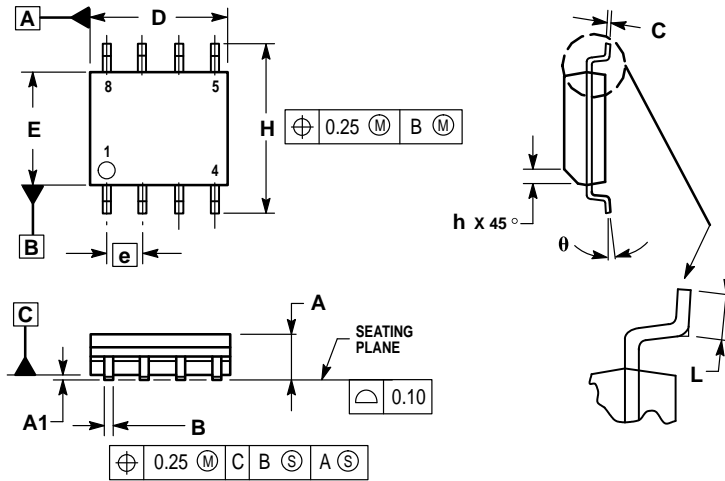

NOTES:

1. DIMENSIONING AND TOLERANCING PER ASME Y14.5M, 1994.
2. DIMENSIONS ARE IN MILLIMETERS.
3. DIMENSION D AND E DO NOT INCLUDE MOLD PROTRUSION.
4. MAXIMUM MOLD PROTRUSION 0.15 PER SIDE.
5. DIMENSION B DOES NOT INCLUDE MOLD PROTRUSION. ALLOWABLE DAMBAR PROTRUSION SHALL BE 0.127 TOTAL IN EXCESS OF THE B DIMENSION AT MAXIMUM MATERIAL CONDITION.

DIM	MILLIMETERS	
	MIN	MAX
A	1.35	1.75
A1	0.10	0.25
B	0.35	0.49
C	0.18	0.25
D	4.80	5.00
E	3.80	4.00
e	1.27 BSC	
H	5.80	6.20
h	0.25	0.50
L	0.40	1.25
θ	0°	7°

MC33171 MC33172 MC33174

OUTLINE DIMENSIONS

P SUFFIX PLASTIC PACKAGE CASE 646-06 ISSUE L

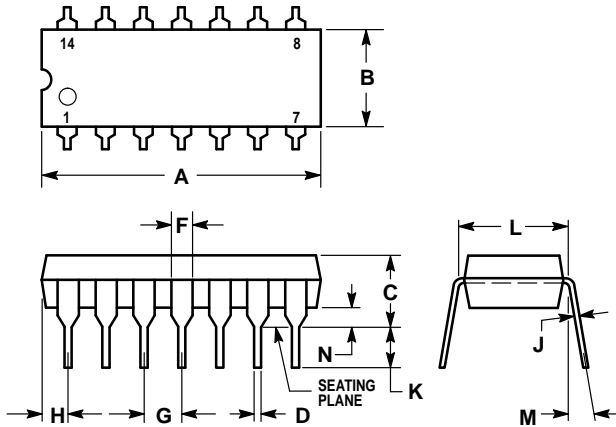

NOTES:

- LEADS WITHIN 0.13 (0.005) RADIUS OF TRUE POSITION AT SEATING PLANE AT MAXIMUM MATERIAL CONDITION.
- DIMENSION L TO CENTER OF LEADS WHEN FORMED PARALLEL.
- DIMENSION B DOES NOT INCLUDE MOLD FLASH.
- ROUNDED CORNERS OPTIONAL.

DIM	INCHES		MILLIMETERS	
	MIN	MAX	MIN	MAX
A	0.715	0.770	18.16	19.56
B	0.240	0.260	6.10	6.60
C	0.145	0.185	3.69	4.69
D	0.015	0.021	0.38	0.53
F	0.040	0.070	1.02	1.78
G	0.100 BSC		2.54 BSC	
H	0.052	0.095	1.32	2.41
J	0.008	0.015	0.20	0.38
K	0.115	0.135	2.92	3.43
L	0.300 BSC		7.62 BSC	
M	0°	10°	0°	10°
N	0.015	0.039	0.39	1.01

D SUFFIX PLASTIC PACKAGE CASE 751A-03 (SO-14) ISSUE F

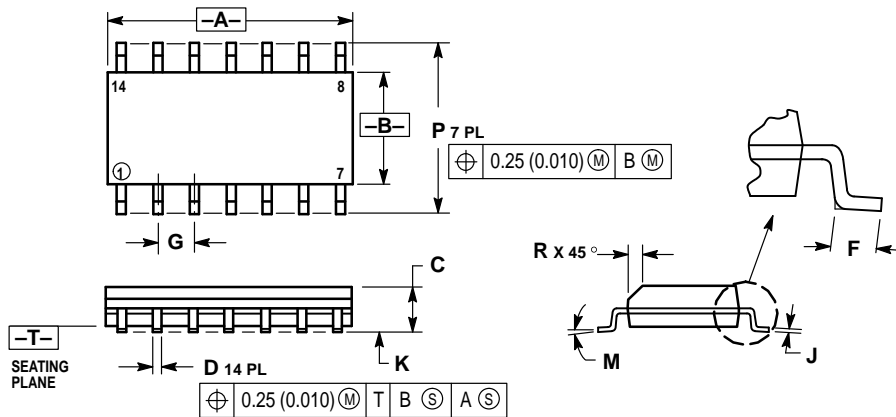

NOTES:

- DIMENSIONING AND TOLERANCING PER ANSI Y14.5M, 1982.
- CONTROLLING DIMENSION: MILLIMETER.
- DIMENSIONS A AND B DO NOT INCLUDE MOLD PROTRUSION.
- MAXIMUM MOLD PROTRUSION 0.15 (0.006) PER SIDE.
- DIMENSION D DOES NOT INCLUDE DAMBAR PROTRUSION. ALLOWABLE DAMBAR PROTRUSION SHALL BE 0.127 (0.005) TOTAL IN EXCESS OF THE D DIMENSION AT MAXIMUM MATERIAL CONDITION.

DIM	MILLIMETERS		INCHES	
	MIN	MAX	MIN	MAX
A	8.55	8.75	0.337	0.344
B	3.80	4.00	0.150	0.157
C	1.35	1.75	0.054	0.068
D	0.35	0.49	0.014	0.019
F	0.40	1.25	0.016	0.049
G	1.27 BSC		0.050 BSC	
J	0.19	0.25	0.008	0.009
K	0.10	0.25	0.004	0.009
M	0°	7°	0°	7°
P	5.80	6.20	0.228	0.244
R	0.25	0.50	0.010	0.019

MC33171 MC33172 MC33174
NOTES

MC33171 MC33172 MC33174
NOTES

MC33171 MC33172 MC33174

Motorola reserves the right to make changes without further notice to any products herein. Motorola makes no warranty, representation or guarantee regarding the suitability of its products for any particular purpose, nor does Motorola assume any liability arising out of the application or use of any product or circuit, and specifically disclaims any and all liability, including without limitation consequential or incidental damages. "Typical" parameters which may be provided in Motorola data sheets and/or specifications can and do vary in different applications and actual performance may vary over time. All operating parameters, including "Typicals" must be validated for each customer application by customer's technical experts. Motorola does not convey any license under its patent rights nor the rights of others. Motorola products are not designed, intended, or authorized for use as components in systems intended for surgical implant into the body, or other applications intended to support or sustain life, or for any other application in which the failure of the Motorola product could create a situation where personal injury or death may occur. Should Buyer purchase or use Motorola products for any such unintended or unauthorized application, Buyer shall indemnify and hold Motorola and its officers, employees, subsidiaries, affiliates, and distributors harmless against all claims, costs, damages, and expenses, and reasonable attorney fees arising out of, directly or indirectly, any claim of personal injury or death associated with such unintended or unauthorized use, even if such claim alleges that Motorola was negligent regarding the design or manufacture of the part. Motorola and  are registered trademarks of Motorola, Inc. Motorola, Inc. is an Equal Opportunity/Affirmative Action Employer.

How to reach us:

USA/EUROPE/Locations Not Listed: Motorola Literature Distribution;
P.O. Box 20912; Phoenix, Arizona 85036. 1-800-441-2447 or 602-303-5454

MFAX: RMFAX0@email.sps.mot.com – TOUCHTONE 602-244-6609
INTERNET: <http://Design-NET.com>

JAPAN: Nippon Motorola Ltd.; Tatsumi-SPD-JLDC, 6F Seibu-Butsuryu-Center,
3-14-2 Tatsumi Koto-Ku, Tokyo 135, Japan. 03-81-3521-8315

ASIA/PACIFIC: Motorola Semiconductors H.K. Ltd.; 8B Tai Ping Industrial Park,
51 Ting Kok Road, Tai Po, N.T., Hong Kong. 852-26629298



MOTOROLA