

OPA603

## High Speed, Current-Feedback, High Voltage OPERATIONAL AMPLIFIER

### FEATURES

- WIDE SUPPLY RANGE:  $\pm 4.5$  to  $\pm 18$ V
- BANDWIDTH: 100MHz,  $G = 1$  to 10
- SLEW RATE: 1000V/ $\mu$ s
- FAST SETTling TIME: 50ns to 0.1%
- HIGH OUTPUT CURRENT:  $\pm 150$ mA peak
- HIGH OUTPUT VOLTAGE:  $\pm 12$ V

### APPLICATIONS

- VIDEO AMPLIFIER
- PULSE AMPLIFIER
- SONAR, ULTRASOUND BUFFERS
- ATE PIN DRIVERS
- xDSL LINE DRIVER
- FAST DATA ACQUISITION
- WAVEFORM GENERATORS

### DESCRIPTION

The OPA603 is a high-speed current-feedback op amp with guaranteed specifications at both  $\pm 5$ V and  $\pm 15$ V power supplies. It can deliver full  $\pm 10$ V signals into 150 $\Omega$  loads with up to 1000V/ $\mu$ s slew rate. This allows it to drive terminated 75 $\Omega$  cables. With 150mA peak output current capability it is suitable for driving load capacitance or long lines at high speed.

In contrast with conventional op amps, the current-feedback approach provides nearly constant bandwidth and settling time over a wide range of closed-loop voltage gains.

The OPA603 is available in a plastic 8-pin DIP and SO-16 surface-mount packages, specified over the industrial temperature range.

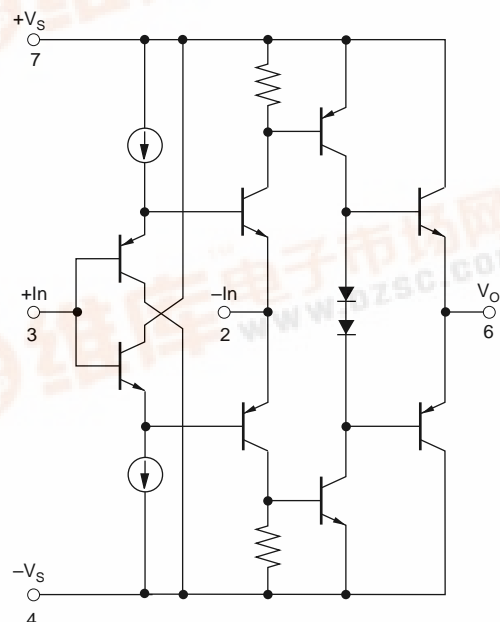

# SPECIFICATIONS: $V_S = \pm 15V$

## ELECTRICAL

At  $T_A = +25^\circ C$ , and  $R_L = 150\Omega$ , unless otherwise noted.

PARAMETER	CONDITIONS	OPA603AP, AU			UNITS
		MIN	TYP	MAX	
<b>INPUT OFFSET VOLTAGE</b> Initial vs Temperature vs Common-Mode Voltage vs Supply (tracking) Voltage vs Supply (non-tracking) <sup>(1)</sup>	$V_{CM} = \pm 10V$ $V_S = \pm 12V$ to $\pm 18V$ $ V_S  = 12V$ to $18V$		8	5	mV $\mu V/^\circ C$ dB dB dB
<b>+INPUT BIAS CURRENT</b> Initial vs Temperature vs Common-Mode vs Supply (tracking) vs Supply (non-tracking) <sup>(1)</sup>	$V_{CM} = \pm 10V$ $V_S = \pm 12V$ to $\pm 18V$ $ V_S  = 12V$ to $18V$		30	5	$\mu A$ nA/ $^\circ C$ nA/V nA/V nA/V
<b>-INPUT BIAS CURRENT</b> Initial vs Temperature vs Common-Mode vs Supply (tracking) vs Supply (non-tracking) <sup>(1)</sup>	$V_{CM} = \pm 10V$ $V_S = \pm 12V$ to $\pm 18V$ $ V_S  = 12V$ to $18V$		300	25	$\mu A$ nA/ $^\circ C$ nA/V nA/V nA/V
<b>INPUT IMPEDANCE</b> +Input -Input			5    2 30    2		M $\Omega$    pF $\Omega$    pF
<b>OPEN LOOP CHARACTERISTICS</b> Transresistance Transcapacitance	$V_O = \pm 10V$	300	440 1.8		k $\Omega$ pF
<b>OUTPUT CHARACTERISTICS</b> Voltage Peak Current Short-Circuit Current <sup>(2)</sup> Output Resistance, Open-Loop	$R_L = 150\Omega$ $V_O = 0V$	$\pm 10$	$\pm 12$ 150 250 70		V mA mA $\Omega$
<b>FREQUENCY RESPONSE</b> Small-Signal Bandwidth <sup>(3)</sup> Gain Flatness, $\pm 0.5dB$ Full-Power Bandwidth Differential Gain Differential Phase	$G = +2$ $V_O = 20Vp-p$ $f = 4.43MHz$ , $V_O = 1V$ $f = 4.43MHz$ , $V_O = 1V$	70 35	160 75 10 0.03 0.025		MHz MHz MHz % Degrees
<b>TIME DOMAIN RESPONSE</b> Propagation Delay Rise and Fall Time Settling Time to 0.10% Slew Rate	$G = +2$ 10V Step		10 10 50 1000		ns ns ns V/ $\mu s$
<b>DISTORTION</b> 2nd Harmonic Distortion 3rd Harmonic Distortion	$G = +2$ , $R_L = 100\Omega$ , $f = 10MHz$ $V_O = 0.2Vp-p$ $V_O = 0.2Vp-p$	-60 -70	-65 -90		dBc dBc
<b>POWER SUPPLY</b> Specified Operating Voltage Operating Voltage Range Current		$\pm 4.5$	$\pm 15$ $\pm 21$	$\pm 18$ $\pm 25$	V V mA
<b>TEMPERATURE RANGE</b> Specification Storage		-25 -40		+85 +150	$^\circ C$ $^\circ C$
<b>THERMAL RESISTANCE, <math>\theta_{JA}</math></b>	Soldered to Printed Circuit		90		$^\circ C/W$

NOTES: (1) One power supply fixed at 15V; the other supply varied from 12V to 18V. (2) Observe power derating curve. (3) See bandwidth versus gain curve, Figure 5.

The information provided herein is believed to be reliable; however, BURR-BROWN assumes no responsibility for inaccuracies or omissions. BURR-BROWN assumes no responsibility for the use of this information, and all use of such information shall be entirely at the user's own risk. Prices and specifications are subject to change without notice. No patent rights or licenses to any of the circuits described herein are implied or granted to any third party. BURR-BROWN does not authorize or warrant any BURR-BROWN product for use in life support devices and/or systems.

# SPECIFICATIONS: $V_S = \pm 5V$

## ELECTRICAL

At  $T_A = +25^\circ C$ , and  $R_L = 75\Omega$ , unless otherwise noted.

PARAMETER	CONDITIONS	OPA603AP, AU			UNITS
		MIN	TYP	MAX	
<b>INPUT OFFSET VOLTAGE</b> Initial vs Temperature vs Common-Mode vs Supply (tracking) vs Supply (non-tracking) <sup>(1)</sup>	$V_{CM} = \pm 3V$ $V_S = \pm 4V$ to $\pm 6V$ $ V_S  = 4V$ to $6V$			6	mV $\mu V/^\circ C$ dB dB dB
<b>+INPUT BIAS CURRENT</b> Initial vs Temperature vs Common-Mode vs Supply (tracking) vs Supply (non-tracking) <sup>(1)</sup>	$V_{CM} = \pm 3V$ $V_S = \pm 4V$ to $\pm 6V$ $ V_S  = 4V$ to $6V$			5	$\mu A$ $nA/^\circ C$ nA/V nA/V nA/V
<b>-INPUT BIAS CURRENT</b> Initial vs Temperature vs Common-Mode vs Supply (tracking) vs Supply (non-tracking) <sup>(1)</sup>	$V_{CM} = \pm 3V$ $V_S = \pm 4V$ to $\pm 6V$ $ V_S  = 4V$ to $6V$			25	$\mu A$ $nA/^\circ C$ nA/V nA/V nA/V
<b>INPUT IMPEDANCE</b> +Input -Input					$M\Omega \parallel pF$ $\Omega \parallel pF$
<b>OPEN LOOP CHARACTERISTICS</b> Transresistance Transcapacitance	$V_O = \pm 2V$	225	330		k $\Omega$ pF
<b>OUTPUT CHARACTERISTICS</b> Voltage Peak Current Short-Circuit Current <sup>(2)</sup> Output Resistance, Open-Loop	$R_L = 75\Omega$ $V_O = 0V$	$\pm 2$	$\pm 2.75$ 150 250 80		V mA mA $\Omega$
<b>FREQUENCY RESPONSE</b> Small-Signal Bandwidth <sup>(3)</sup> Gain Flatness, $\pm 0.5dB$ Full-Power Bandwidth Differential Gain Differential Phase	$G = +2$  $f = 4.43MHz, V_O = 1V, R_L = 150\Omega$ $f = 4.43MHz, V_O = 1V, R_L = 150\Omega$		140 65 20 0.03 0.025		MHz MHz MHz % Degrees
<b>TIME DOMAIN RESPONSE</b> Propagation Delay Rise and Fall Time Settling Time to 0.10% Slew Rate	$G = +2, R_L = 100\Omega$		15 20 60 750		ns ns ns V/ $\mu s$
<b>DISTORTION</b> 2nd Harmonic Distortion 3rd Harmonic Distortion	$G = +2, R_L = 100\Omega, f = 10MHz$ $V_O = 0.2Vp-p$ $V_O = 0.2Vp-p$		-67 -78		dBc dBc
<b>POWER SUPPLY</b> Specified Operating Voltage Operating Voltage Range Current		$\pm 4.5$	$\pm 5$ $\pm 21$	$\pm 18$ $\pm 25$	V V mA
<b>TEMPERATURE RANGE</b> Specification Storage		-25 -40		+85 +150	$^\circ C$ $^\circ C$
<b>THERMAL RESISTANCE, <math>\theta_{JUNCTION-AMBIENT}</math></b>	Soldered to Printed Circuit		90		$^\circ C/W$

NOTES: (1) One power supply fixed at 5V; the other supply varied from 4V to 6V. (2) Observe power derating curve. (3) See bandwidth versus gain curves, Figure 5.

## PIN CONFIGURATION

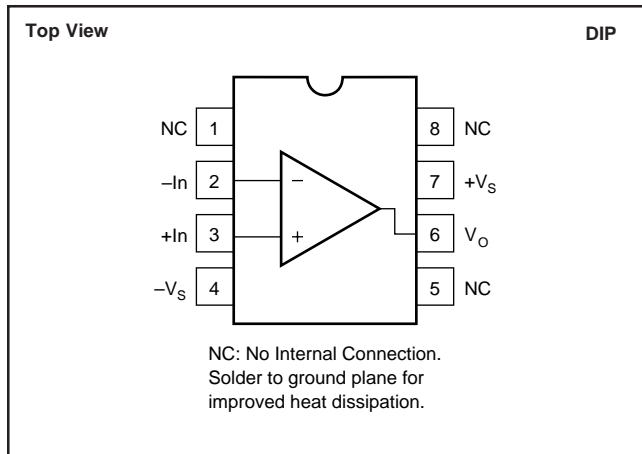

## PIN CONFIGURATION

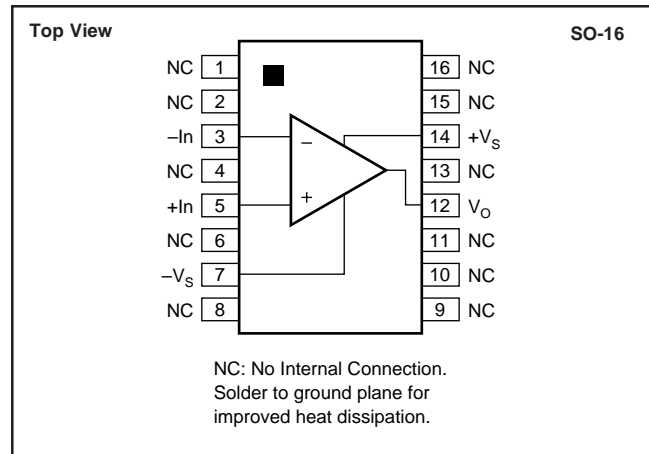

## ABSOLUTE MAXIMUM RATINGS

Supply Voltage .....	$\pm 18V$
Input Voltage Range .....	$\pm V_S$
Differential Input Voltage .....	$\pm 6V$
Power Dissipation .....	See derating curve
Operating Temperature .....	$+100^\circ C$
Storage Temperature .....	$+150^\circ C$
Junction Temperature .....	$+150^\circ C$
Lead Temperature (soldering, 10s) .....	$+300^\circ C$
Lead Temperature (soldering SO-16 package, 3s) .....	$+260^\circ C$



## ELECTROSTATIC DISCHARGE SENSITIVITY

This integrated circuit can be damaged by ESD. Burr-Brown recommends that all integrated circuits be handled with appropriate precautions. Failure to observe proper handling and installation procedures can cause damage.

ESD damage can range from subtle performance degradation to complete device failure. Precision integrated circuits may be more susceptible to damage because very small parametric changes could cause the device not to meet its published specifications.

## PACKAGE/ORDERING INFORMATION

PRODUCT	PACKAGE	PACKAGE DRAWING NUMBER <sup>(1)</sup>	SPECIFIED TEMPERATURE RANGE
OPA603AP	Plastic DIP	006	$-25^\circ C$ to $+85^\circ C$
OPA603AU	SO-16	211	$-25^\circ C$ to $+85^\circ C$

NOTE: (1) For detailed drawing and dimension table, please see end of data sheet, or Appendix C of Burr-Brown IC Data Book.

# TYPICAL PERFORMANCE CURVES

At  $T_A = +25^\circ\text{C}$ , unless otherwise noted.

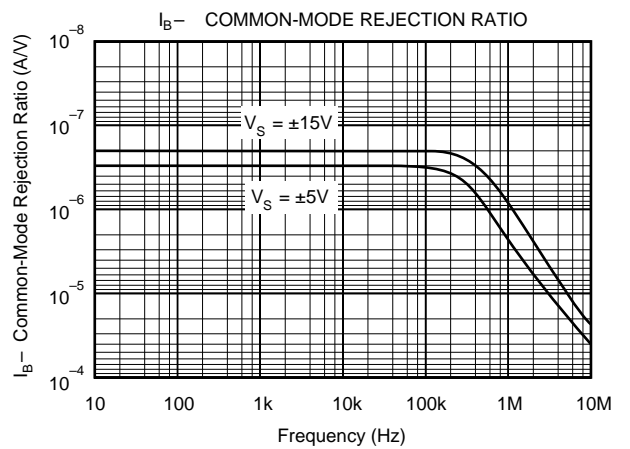
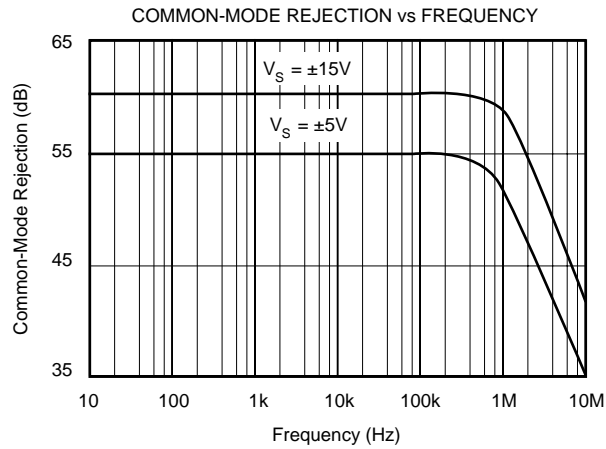
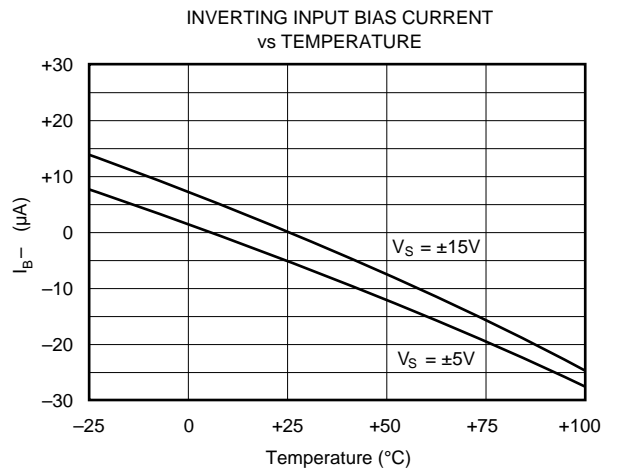
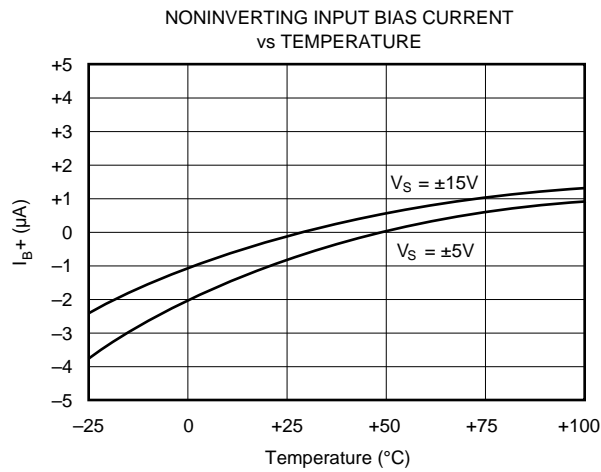
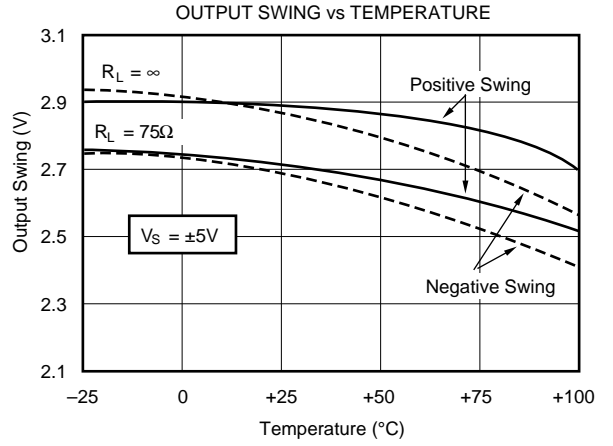
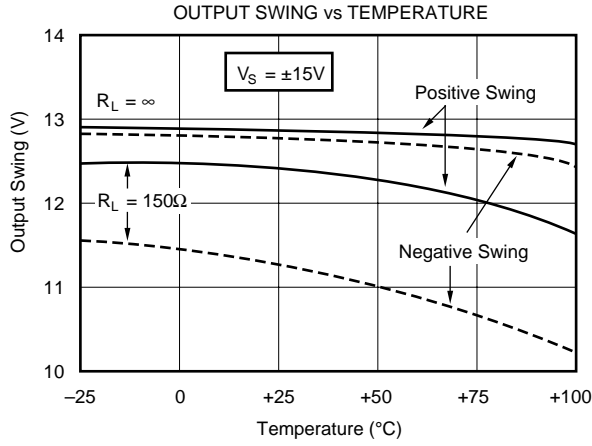

# TYPICAL PERFORMANCE CURVES (CONT)

At  $T_A = +25^\circ\text{C}$ , unless otherwise noted.

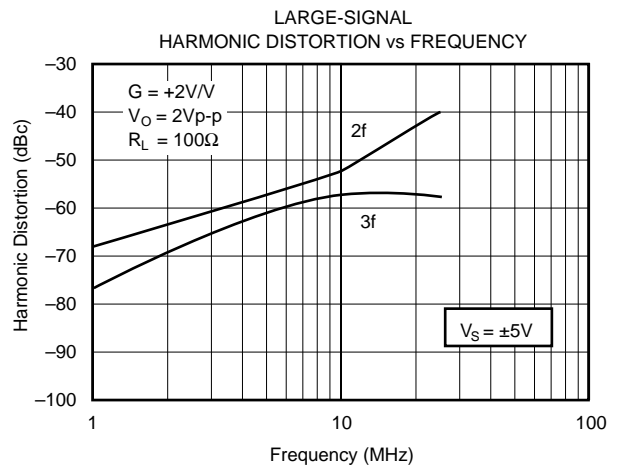
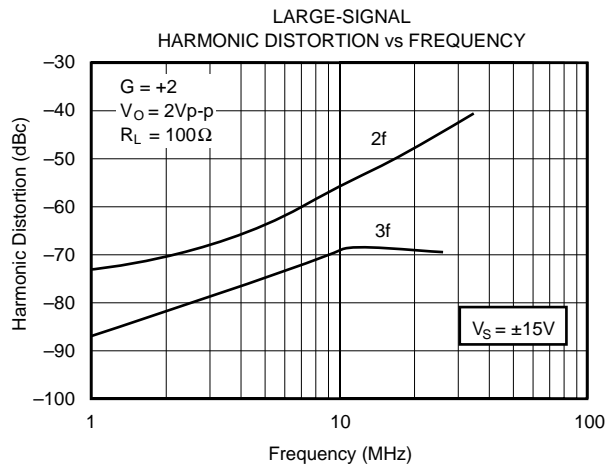
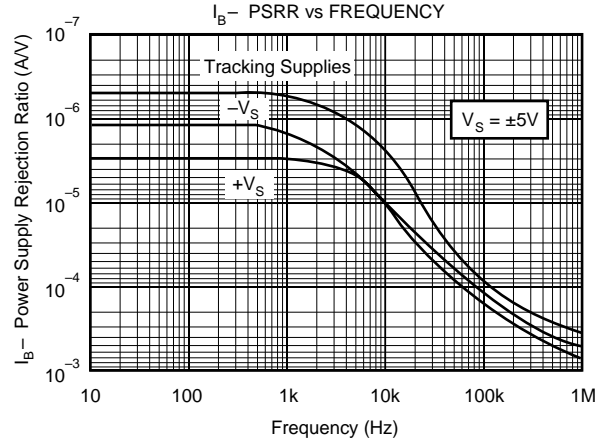
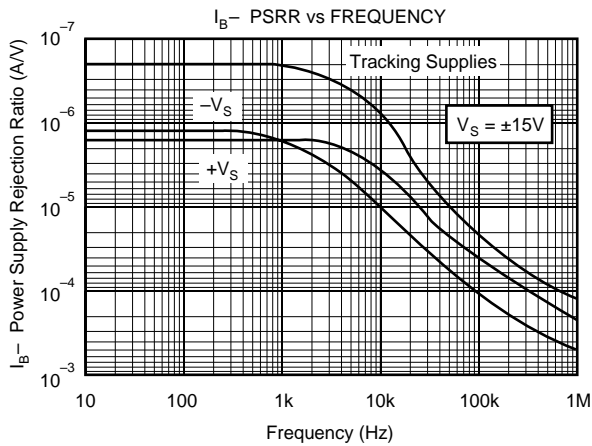
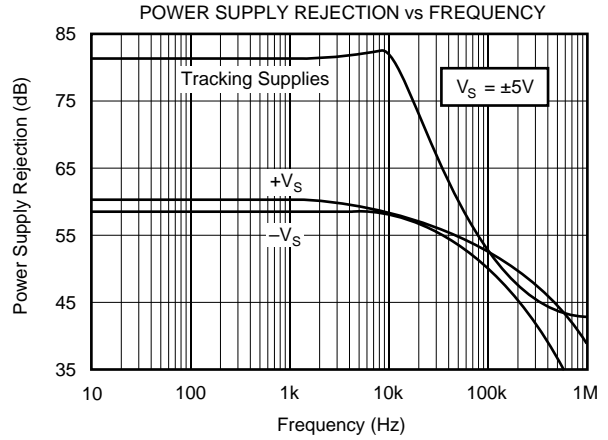
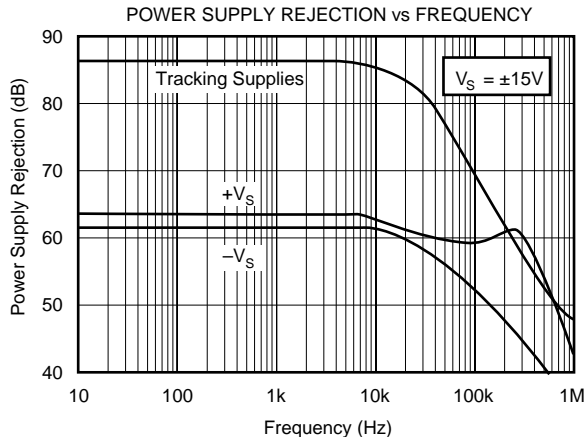

# TYPICAL PERFORMANCE CURVES (CONT)

At  $T_A = +25^\circ\text{C}$ , unless otherwise noted.

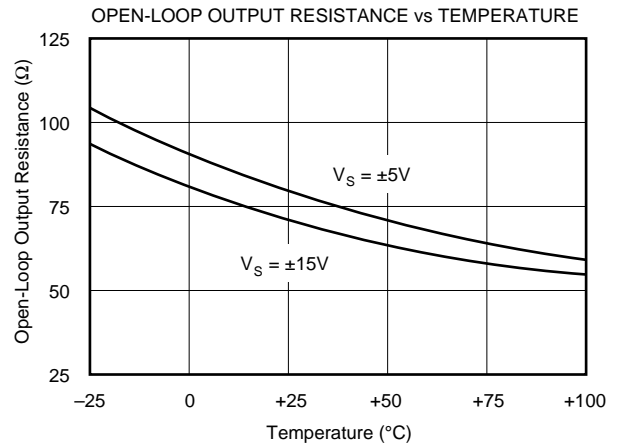
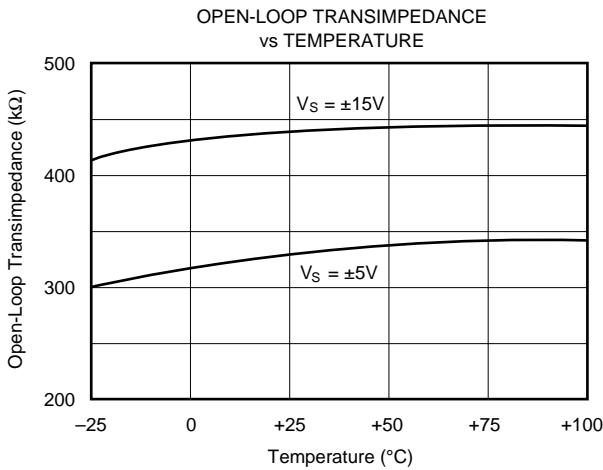
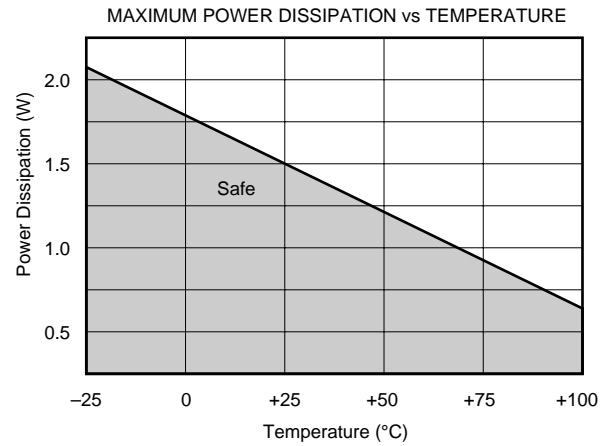
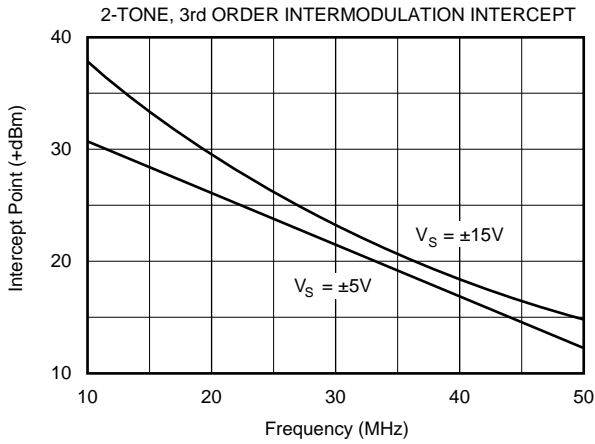
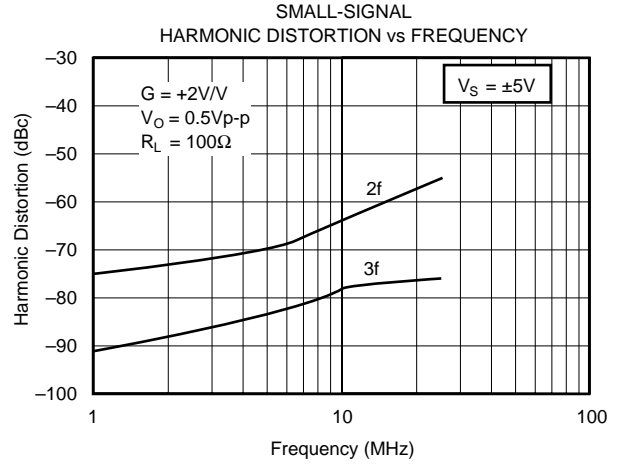
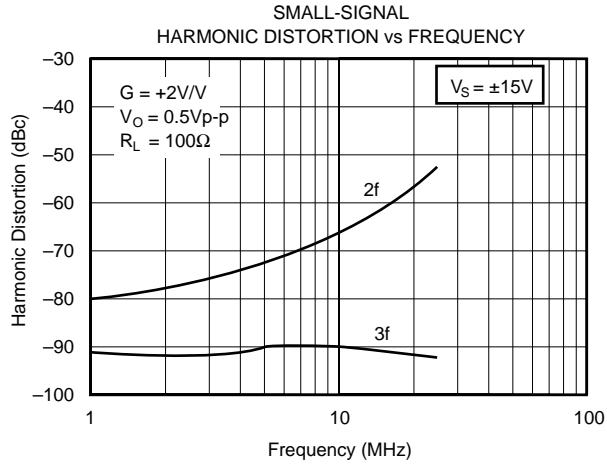

# TYPICAL PERFORMANCE CURVES (CONT)

At  $T_A = +25^\circ\text{C}$ , unless otherwise noted.

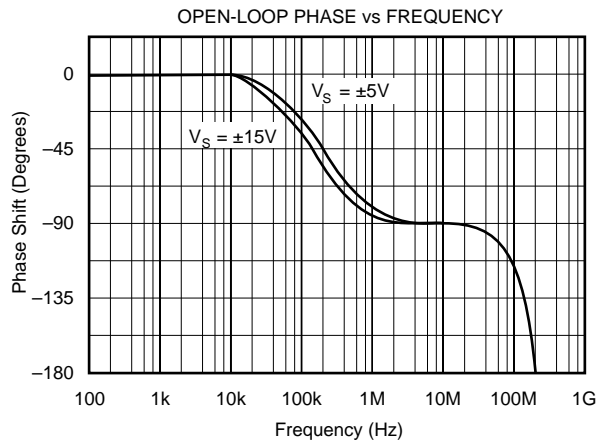
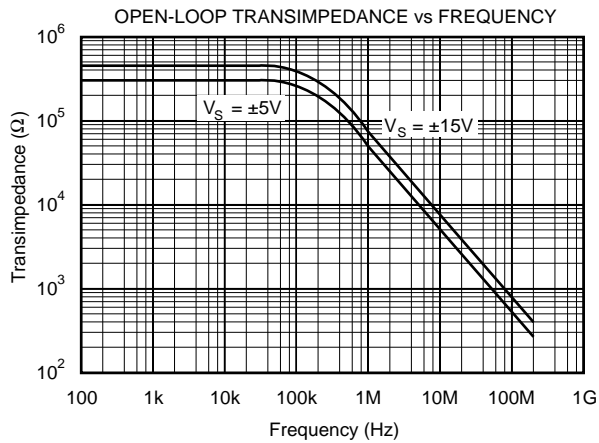
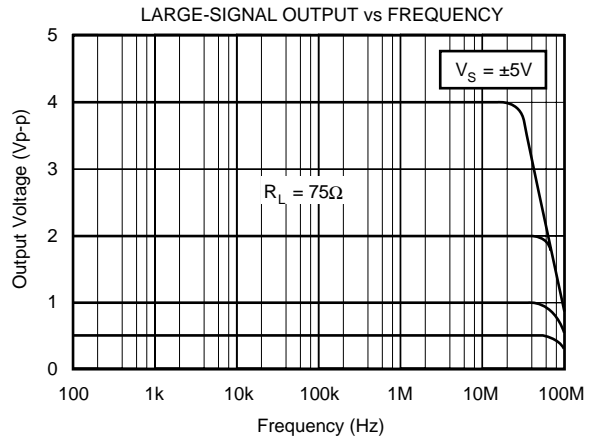
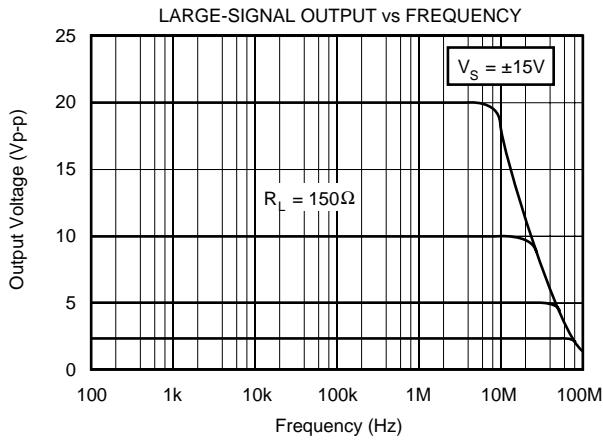
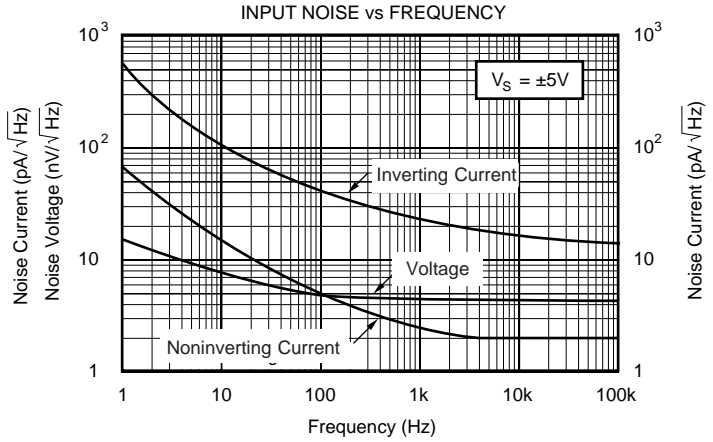
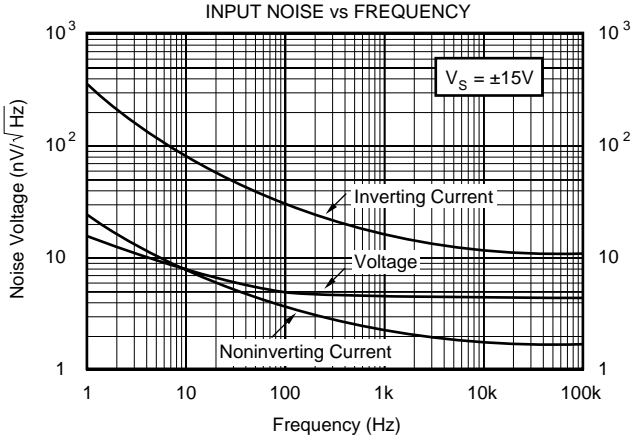



# TYPICAL PERFORMANCE CURVES (CONT)

At  $T_A = +25^\circ\text{C}$ , unless otherwise noted.

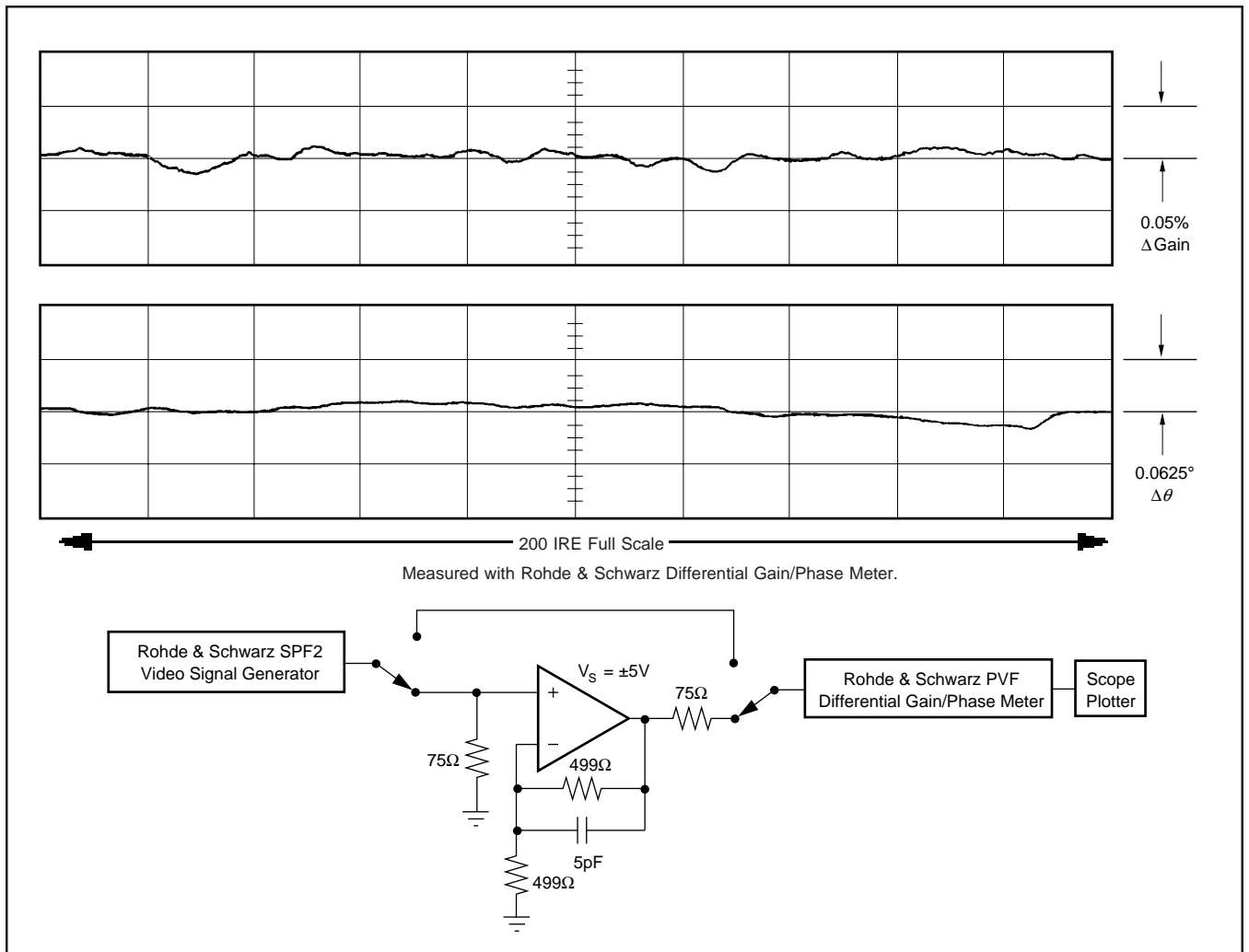
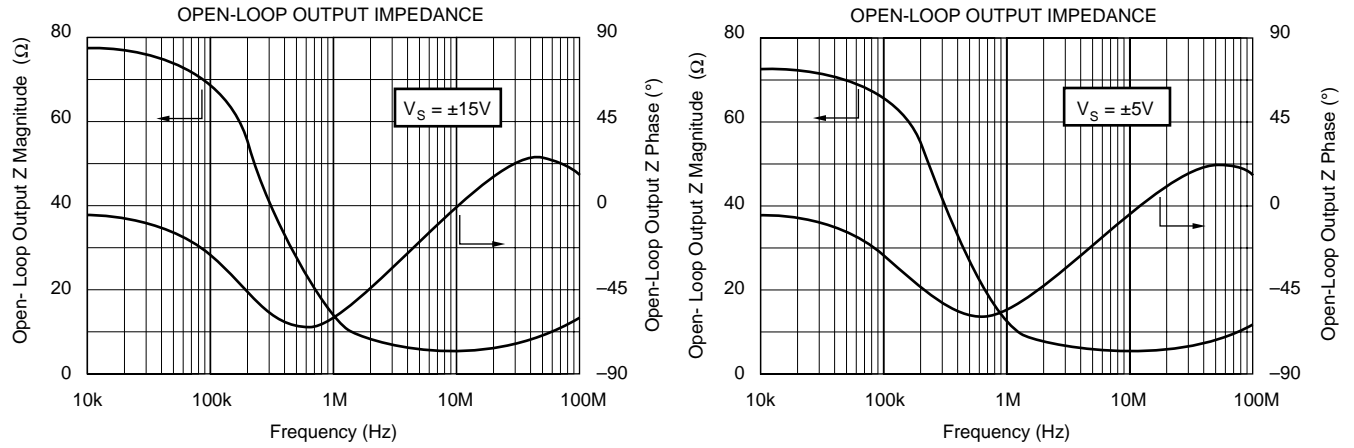

FIGURE 1. Video Differential Gain/Phase Performance.

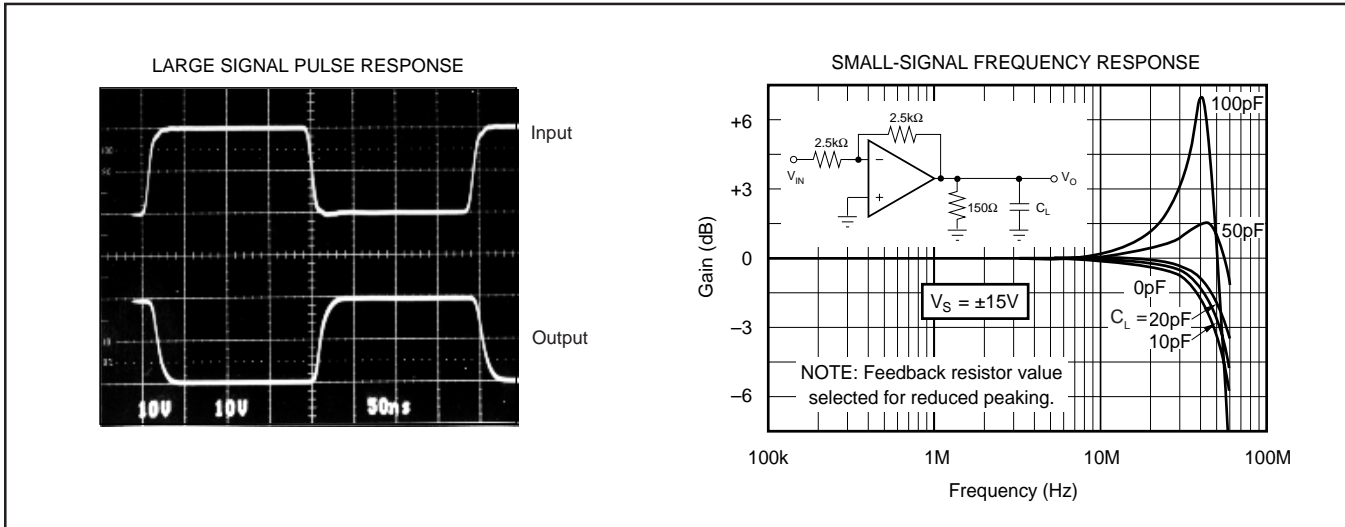

FIGURE 2. Dynamic Response, Inverting Unity-Gain.

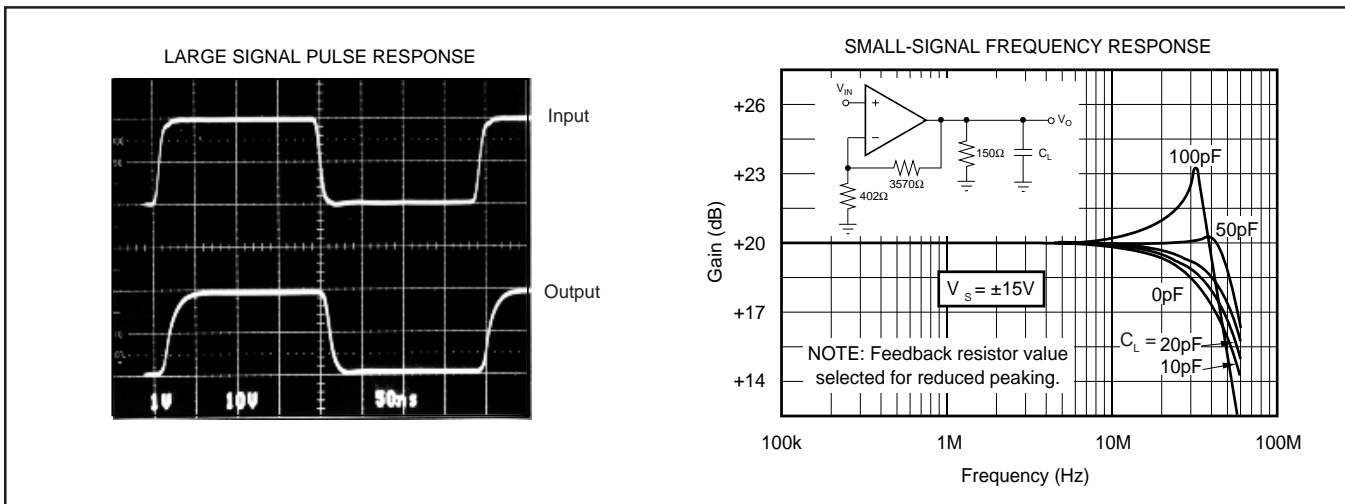

FIGURE 3. Dynamic Response, Gain = +10.

## APPLICATIONS INFORMATION

For most circuit configurations, the OPA603 current-feedback op amp can be treated like a conventional op amp. As with a conventional op amp, the feedback network connected to the inverting input controls the closed-loop gain. But with a current-feedback op amp, the impedance of the feedback network also controls the open-loop gain and frequency response.

Feedback resistor values can be selected to provide a nearly constant closed-loop bandwidth over a very wide range of gain. This is in contrast to a conventional op amp where circuit bandwidth is inversely proportional to the closed-loop gain, sharply limiting bandwidth at high gain.

Figures 4a and 4b show appropriate feedback resistor values versus closed-loop gain for maximum bandwidth with minimal peaking. The dual vertical axes of these curves also show the resulting bandwidth. Note that the bandwidth remains nearly constant as gain is increased.

With control of the open-loop characteristics of the op amp, dynamic behavior can be tailored to an application's requirements. Lower feedback resistance gives wider bandwidth, more frequency-response peaking and more pulse response overshoot. The higher open-loop gain resulting from lower feedback network resistors also yields lower distortion. Higher feedback network resistance gives an over-damped response with little or no peaking and overshoot. This may be beneficial when driving capacitive loads. Feedback network impedance can also be varied to optimize dynamic performance. To achieve wider bandwidth, use a feedback resistor value somewhat lower than indicated in Figure 4.

## EXTENDING BANDWIDTH

For gains less than approximately 20, bandwidth can be extended by adding a capacitor,  $C_F$ , in parallel with a lower value for  $R_F$ . The optimum feedback resistor value in this case is far lower than those shown in Figure 1. For  $\pm 15V$  operation, select  $R_F$  with the following equation:

$$R_F (\Omega) = 30 \cdot (30 - G) \text{ for } V_S = \pm 15V$$

For example, for a gain of 10, use  $R_F = 600\Omega$ . Optimum values differ slightly for  $\pm 5V$  operation:

$$R_F (\Omega) = 30 \cdot (23 - G) \text{ for } V_S = \pm 5V$$

$C_F$  will range from 1pF to 10pF depending on the selected gain, load, and circuit layout. Adjust  $C_F$  to optimize bandwidth and minimize peaking. Figure 5 shows bandwidth which can be achieved using this technique.

Typical values for this capacitor range from 1pF to 10pF depending on closed-loop gain and load characteristics. Too large a value of  $C_F$  can cause instability.

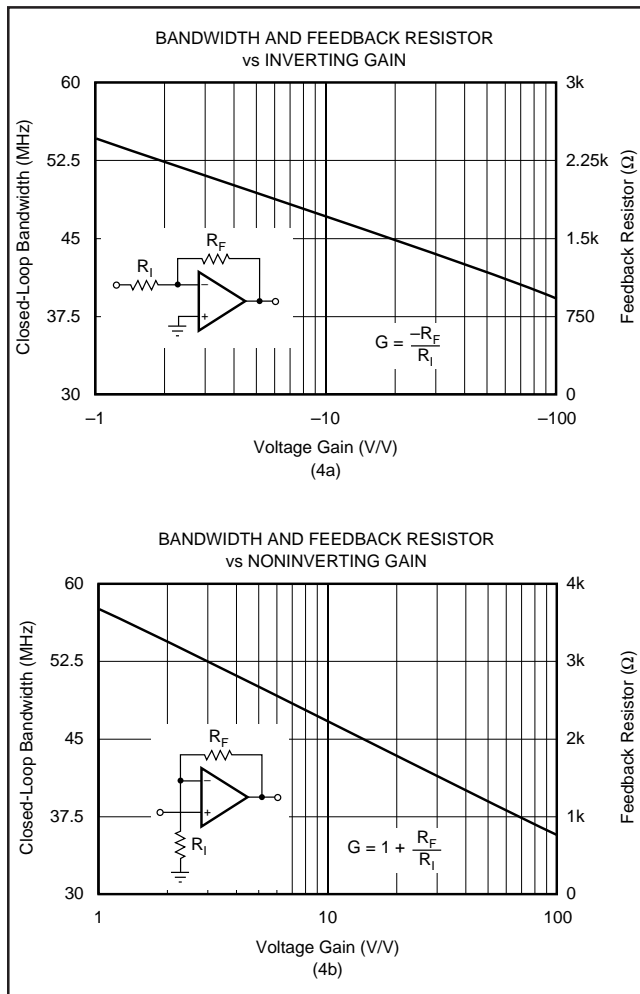

FIGURE 4. Feedback Resistor Selection Curves.

### UNITY-GAIN OPERATION

As Figure 4b indicates, the OPA603 can be operated in unity gain. A feedback resistor (approximately  $2.8k\Omega$ ) sets the appropriate open-loop characteristics and resistor  $R_I$  is omitted. Just as with gains greater than one, the value of the feedback resistor (and capacitor if used) can be optimized for the desired dynamic response and load characteristics.

Care should be exercised not to exceed the maximum differential input voltage rating of  $\pm 6V$ . Large input voltage steps which exceed the device's slew rate of  $1000V/\mu s$  can apply excessive differential input voltage.

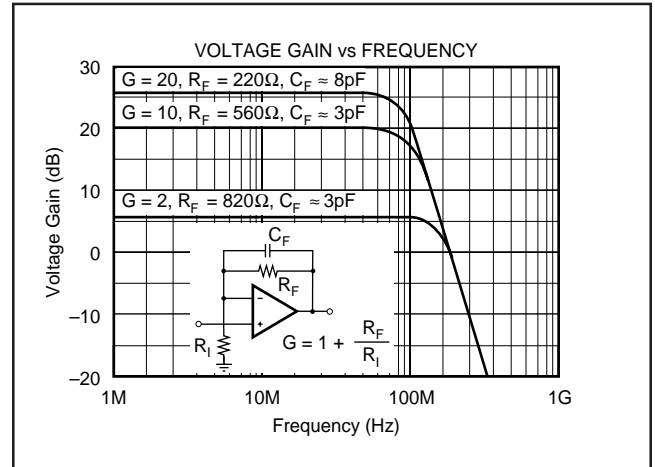

FIGURE 5. Bandwidth Results with Added Capacitor  $C_F$ .

### CIRCUIT LAYOUT

With any high-speed, wide-bandwidth circuitry, careful circuit layout will ensure best performance. Make short, direct circuit interconnections and avoid stray wiring capacitance—especially at the inverting input pin. A component-side ground plane will help ensure low ground impedance. Do not place the ground plane under or near the inputs and feedback network.

Power supplies should be bypassed with good high-frequency capacitors positioned close to the op amp pins. In most cases, a  $0.01\mu F$  ceramic capacitor in parallel with a  $2.2\mu F$  solid tantalum capacitor at each power supply pin is adequate. The OPA603 can deliver high load current—up to 150mA peak. Applications with low impedance or capacitive loads demand large current transients from the power supplies. It is the power supply bypass capacitors which must supply these current transients. Larger bypass capacitors such as  $10\mu F$  solid tantalum capacitors may improve performance in these applications.

### POWER DISSIPATION

High output current causes increased internal power dissipation in the OPA603. Copper leadframe construction maximizes heat dissipation compared to conventional plastic packages. To achieve best heat dissipation, solder the device directly to the circuit board and use wide circuit board traces. Solder the unused pins, (1, 5 and 8) to a top-side ground plane for improved power dissipation. Limit the load and signal conditions depending on maximum ambient temperature to assure operation within the power derating curve.

The OPA603 may be operated at reduced power supply voltage to minimize power dissipation. Detailed specifications are provided for both  $\pm 15V$  and  $\pm 5V$  operation.

# APPLICATIONS CIRCUITS

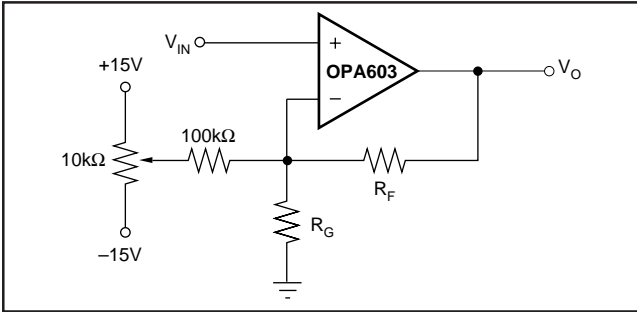

FIGURE 6. Offset Voltage Adjustment.

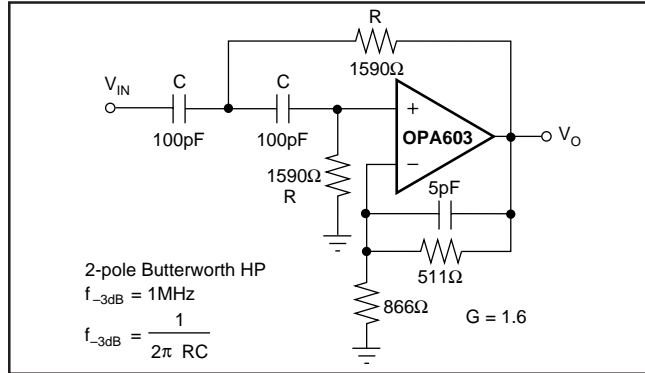

FIGURE 9. High-Pass Filter — 1MHz.

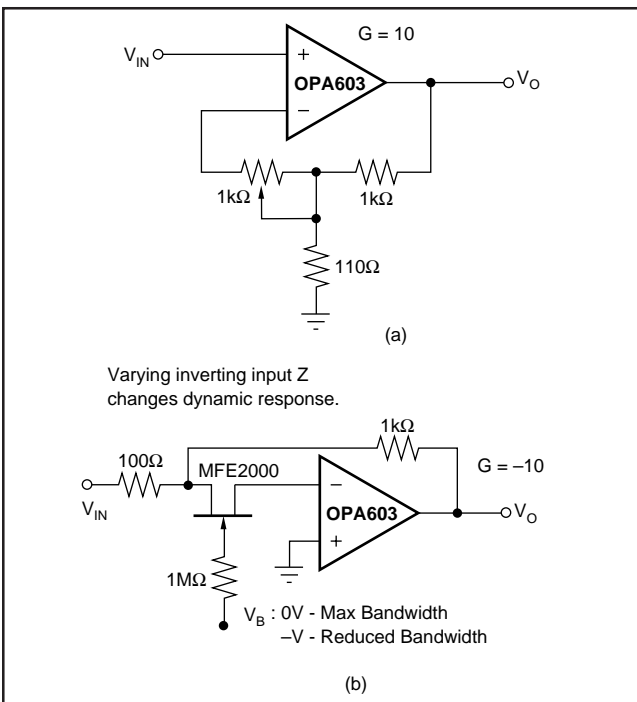

FIGURE 7. Controlling Dynamic Performance.

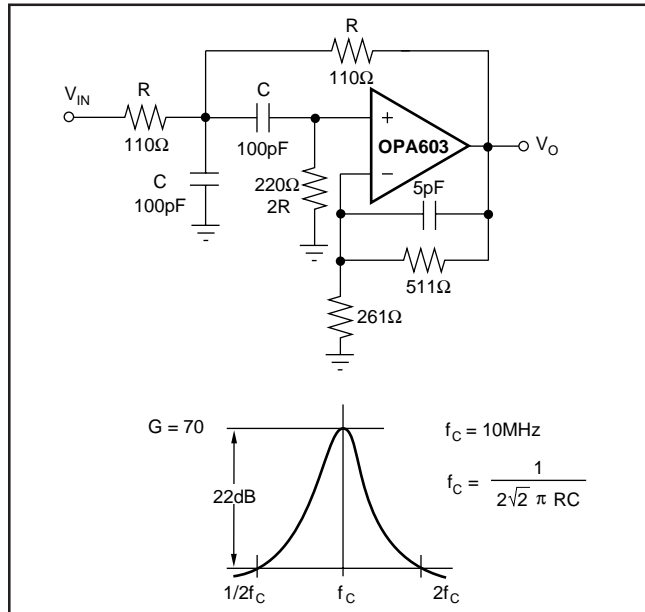

FIGURE 10. Bandpass Filter — 10MHz.

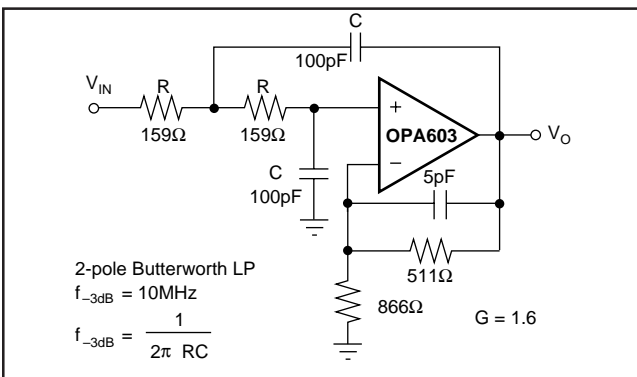

FIGURE 8. Low-Pass Filter — 10MHz.

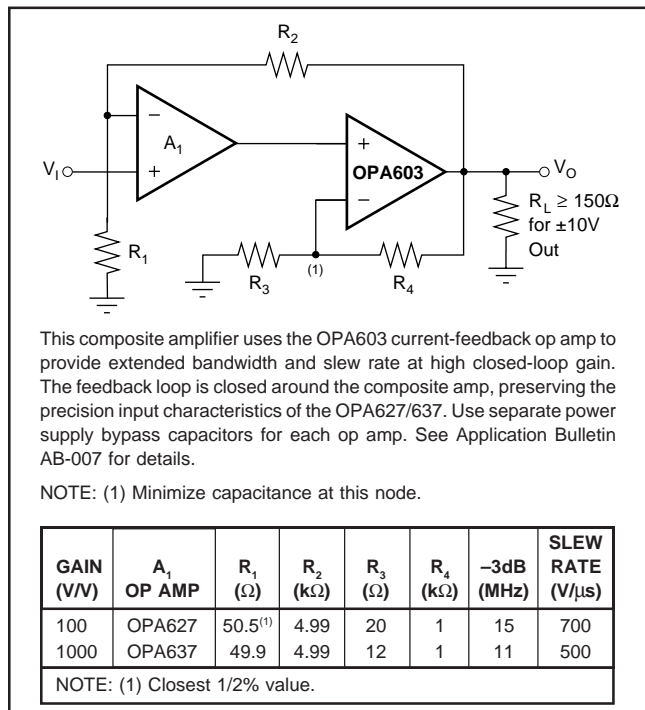

FIGURE 11. Precision-Input Composite Amplifier.