

HCPL2601 OPTOCOUPLER/OPTOISOLATOR

SOOS009 D2968, NOVEMBER 1986

- Gallium Arsenide Phosphide LED Optically Coupled to an Integrated Circuit Detector
- Internal Shield for Common-Mode Rejection
- Compatible with TTL and LSTTL Inputs
- Low Input Current Required to Turn Output On . . . 5 mA Max
- High-Voltage Electrical Insulation . . . 3000 V DC Min
- High-Speed Switching . . . 75 ns Max
- UL Recognized . . . File Number E65085
- Directly Interchangeable with Hewlett Packard HCPL2601

description

The HCPL2601 optocoupler is designed for use in high-speed digital interfacing applications that require high-voltage isolation between the input and output. It is recommended for use in extremely high ground-noise and induced-noise environments. Applications include line receivers, microprocessors or computer interface, digital programming of floating power supplies, motors, and other control systems.

The HCPL2601 high-speed optocoupler consists of a GaAsP light-emitting diode and an integrated light detector composed of a photodiode, a high-gain amplifier, and a Schottky-clamped open-collector output transistor. An input diode forward current of 5 milliamperes will switch the output transistor low, providing an on-state drive current of 13 milliamperes (eight 1.6-milliampere TTL loads). A TTL-compatible enable input is provided for applications that require output-transistor gating.

The HCPL2601 is mounted in a standard 8-pin dual-in-line plastic package.

The HCPL2601 is characterized for operation over the temperature range of 0°C to 70°C. The internal shield provides a guaranteed common-mode transient immunity of 1000 volts/microsecond minimum.

mechanical data

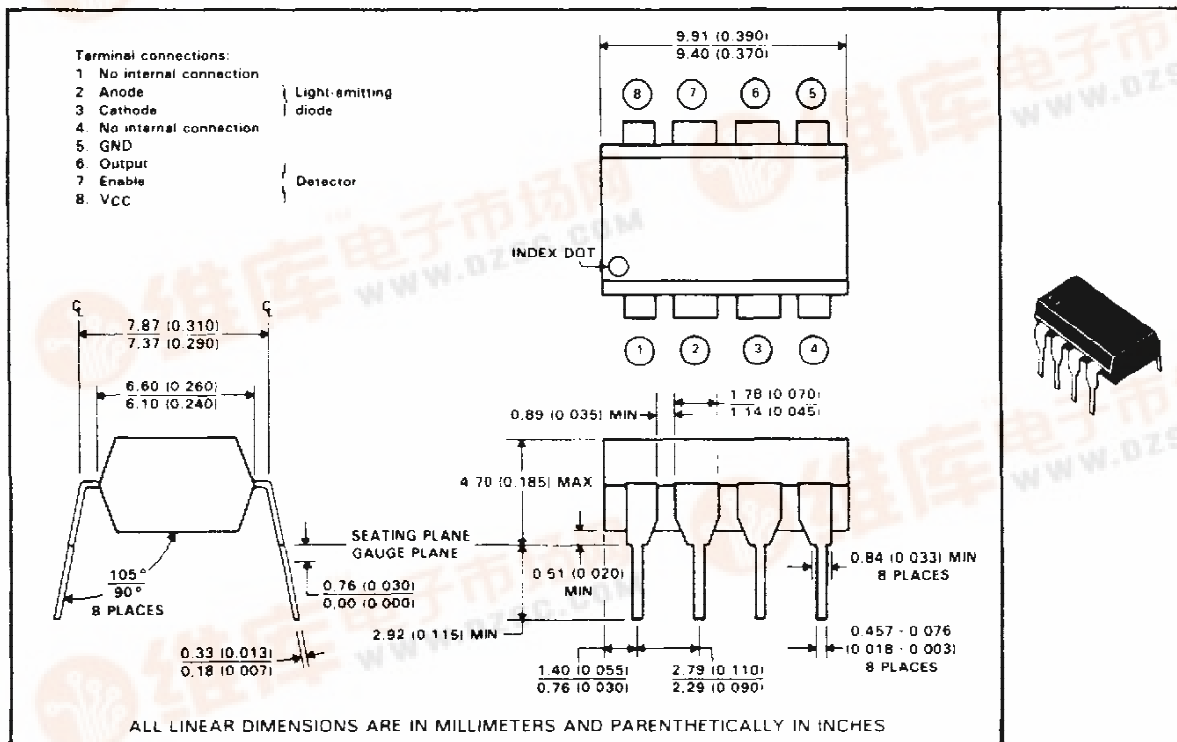

PRODUCTION DATA documents contain information current as of publication date. Products conform to specifications per the terms of Texas Instruments standard warranty. Production processing does not necessarily include testing of all parameters.

TEXAS
INSTRUMENTS

POST OFFICE BOX 055303 • DALLAS, TEXAS 75265

Copyright © 1986, Texas Instruments Incorporated



**HCPL2601
OPTOCOUPLER/OPTOISOLATOR**

FUNCTION TABLE

INPUT	ENABLE	OUTPUT
I _{F(on)}	H	L
I _{F(off)}	X	H
X	L	H

logic diagram (positive logic)

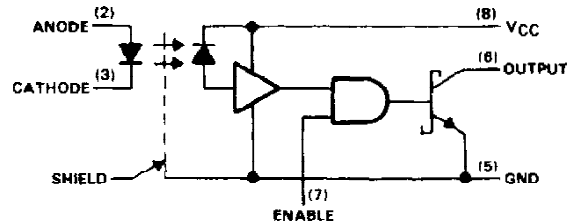

absolute maximum ratings over operating free-air temperature range (unless otherwise noted)

Supply voltage, V _{CC}	7 V
Reverse input voltage	5 V
Enable input voltage (not to exceed V _{CC} by more than 500 mV)	5.5 V
Output voltage	7 V
Peak forward input current (≤ 1 ms duration)	40 mA
Average forward input current	20 mA
Output current	25 mA
Output power dissipation	40 mW
Storage temperature range	-55 °C to 125 °C
Operating free-air temperature range	0 °C to 70 °C
Lead temperature 1,6 mm (1/16 inch) from case for 10 seconds	260 °C

recommended operating conditions

		MIN	NOM	MAX	UNIT
V _{CC}	Output supply voltage (see Note 1)	4.5	5	5.5	V
V _{IH(EN)}	High-level enable input voltage (see Note 2)	2		V _{CC}	V
V _{IL(EN)}	Low-level enable input voltage	0		0.8	V
I _{F(on)}	Input forward current to turn output on	6.3		15	mA
I _{F(off)}	Input forward current to turn output off	0		250	μA
I _{OL}	Low-level (on-state) output current			13	mA
T _A	Operating free-air temperature	0		70	°C

- NOTES: 1. All voltage values are with respect to GND (pin 5).
2. No external pullup is required at the enable input; an open circuit will establish the high level.

HCPL2601 OPTOCOUPLER/OPTOISOLATOR

electrical characteristics over recommended operating free-air temperature range (unless otherwise noted)

PARAMETER		TEST CONDITIONS	MIN	TYP [†]	MAX	UNIT
V_F	Input forward voltage	$I_F = 10 \text{ mA}$, $T_A = 25^\circ\text{C}$		1.6	1.75	V
α_{VF}	Temperature coefficient of forward voltage	$I_F = 10 \text{ mA}$		-1.8		mV/°C
V_{BR}	Input reverse breakdown voltage	$I_R = 10 \mu\text{A}$, $T_A = 25^\circ\text{C}$	5			V
V_{OL}	Low-level output voltage	$V_{CC} = 5.5 \text{ V}$, $V_{(EN)} = 2 \text{ V}$, $I_F = 5 \text{ mA}$, $I_{OL} = 13 \text{ mA}$		0.23	0.6	V
I_{OH}	High-level output current	$V_{CC} = 5.5 \text{ V}$, $V_O = 5.5 \text{ V}$, $V_{(EN)} = 2 \text{ V}$, $I_F = 250 \mu\text{A}$			250	μA
$I_{IH(EN)}$	High-level enable input current	$V_{CC} = 5.5 \text{ V}$, $V_{(EN)} = 2 \text{ V}$		-0.2		mA
$I_{IL(EN)}$	Low-level enable input current	$V_{CC} = 5.5 \text{ V}$, $V_{(EN)} = 0.5 \text{ V}$		-0.5	-2	mA
I_{CCH}	Supply current, high-level output	$V_{CC} = 5.5 \text{ V}$, $V_{(EN)} = 0.5 \text{ V}$, $I_F = 0$		10	15	mA
I_{CCL}	Supply current, low-level output	$V_{CC} = 5.5 \text{ V}$, $V_{(EN)} = 0.5 \text{ V}$, $I_F = 10 \text{ mA}$		13	19	mA
I_{IO}	Input-output insulation leakage current	$V_{IO} = 3000 \text{ V}$, $t = 5 \text{ s}$, $T_A = 25^\circ\text{C}$, $RH = 45\%$, See Note 1			1	μA
r_{IO}	Input-output resistance	$V_{IO} = 500 \text{ V}$, $T_A = 25^\circ\text{C}$, See Note 1		10^{12}		Ω
C_i	Input capacitance	$V_F = 0$, $f = 1 \text{ MHz}$		60		pF
C_{io}	Input-output capacitance	$f = 1 \text{ MHz}$, $T_A = 25^\circ\text{C}$, See Note 1		0.6		pF

[†] All typical values are at $V_{CC} = 5 \text{ V}$, $T_A = 25^\circ\text{C}$.

NOTE 1: These parameters are measured between pins 2 and 3 shorted together and pins 5, 6, 7, and 8 shorted together.

switching characteristics at $V_{CC} = 5 \text{ V}$, $T_A = 25^\circ\text{C}$

PARAMETER		TEST CONDITIONS	MIN	TYP	MAX	UNIT
t_{PLH}	Propagation delay time, low-to-high level output, from LED input	$I_F = 7.5 \text{ mA}$, $R_L = 350 \Omega$, $C_L = 15 \text{ pF}$, See Figure 1		42	75	ns
t_{PHL}	Propagation delay time, high-to-low level output, from LED input	$I_F = 7.5 \text{ mA}$, $R_L = 350 \Omega$, $C_L = 15 \text{ pF}$, See Figure 1		42	75	ns
$t_{PLH(EN)}$	Propagation delay time, low-to-high level output, from enable	$I_F = 7.5 \text{ mA}$, $R_L = 350 \Omega$, $C_L = 15 \text{ pF}$, See Figure 2		40		ns
$t_{PHL(EN)}$	Propagation delay time, high-to-low level output, from enable	$I_F = 7.5 \text{ mA}$, $R_L = 350 \Omega$, $C_L = 15 \text{ pF}$, See Figure 2		25		ns
t_r	Rise time	$I_F = 7.5 \text{ mA}$, $R_L = 350 \Omega$, $C_L = 15 \text{ pF}$		20		ns
t_f	Fall time	$I_F = 7.5 \text{ mA}$, $R_L = 350 \Omega$, $C_L = 15 \text{ pF}$		30		ns
$\frac{dV_{CM}}{dt}$ (H)	Common-mode input transient immunity, high-level output	$\Delta V_{CM} = 50 \text{ V}$, $I_F = 0$, $R_L = 350 \Omega$, See Note 2 and Figure 3	1000	10000		V/ μs
$\frac{dV_{CM}}{dt}$ (L)	Common-mode input transient immunity, low-level output	$\Delta V_{CM} = -50 \text{ V}$, $I_F = 7.5 \text{ mA}$, $R_L = 350 \Omega$, See Note 2 and Figure 3	-1000	-1000		V/ μs

NOTE 2: Common-mode input transient immunity, high-level output, is the maximum rate of rise of the common-mode input voltage that does not cause the output voltage to drop below 2 V. Common-mode input transient immunity, low-level output, is the maximum rate of fall of the common-mode input voltage that does not cause the output voltage to rise above 0.8 V.

**HCPL2601
OPTOCOUPLER/OPTOISOLATOR**

PARAMETER MEASUREMENT INFORMATION

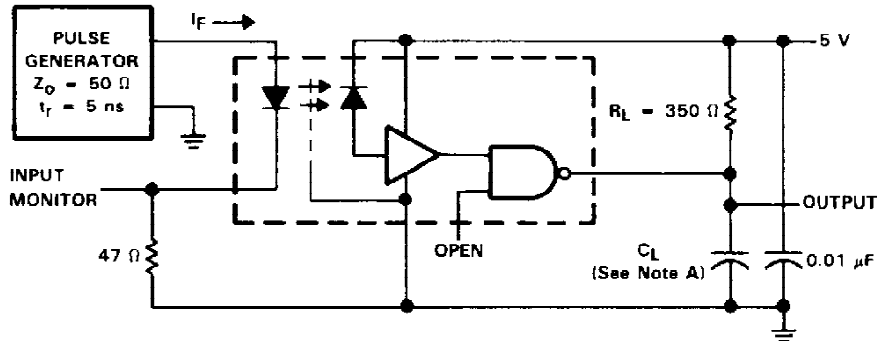

TEST CIRCUIT

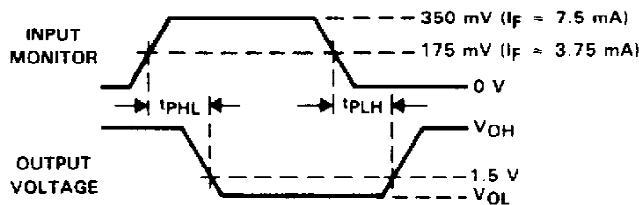

WAVEFORMS

FIGURE 1. t_{PLH} AND t_{PHL} FROM LED INPUT TEST CIRCUIT AND WAVEFORMS

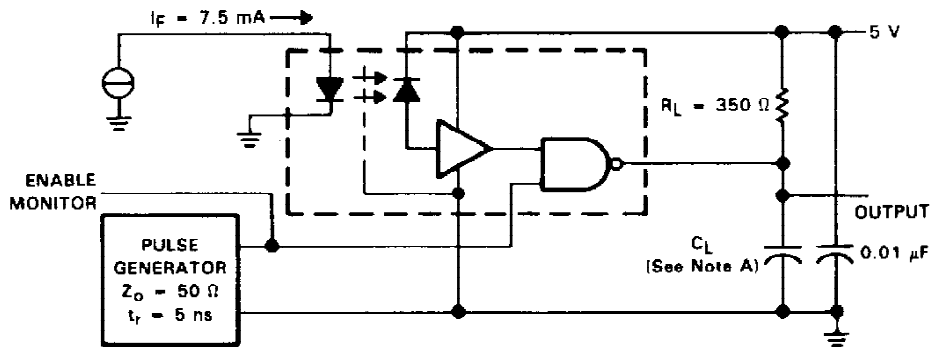

TEST CIRCUIT

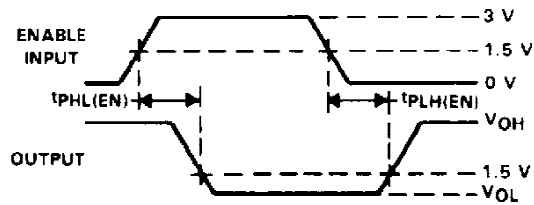

VOLTAGE WAVEFORMS

FIGURE 2. $t_{PLH(EN)}$ AND $t_{PHL(EN)}$ FROM ENABLE TEST CIRCUIT AND WAVEFORMS

NOTE A: C_L is approximately 15 pF, which includes probe and stray wiring capacitances.

PARAMETER MEASUREMENT INFORMATION

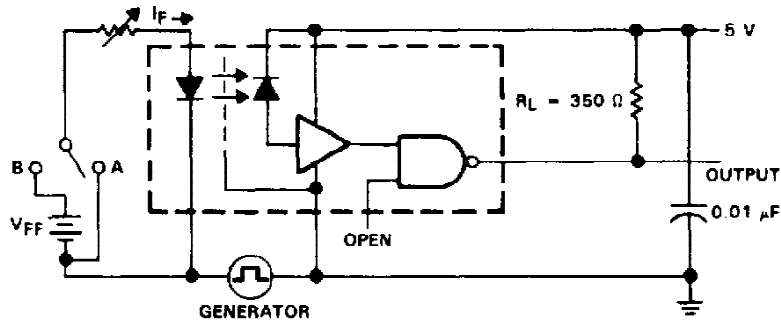

TEST CIRCUIT

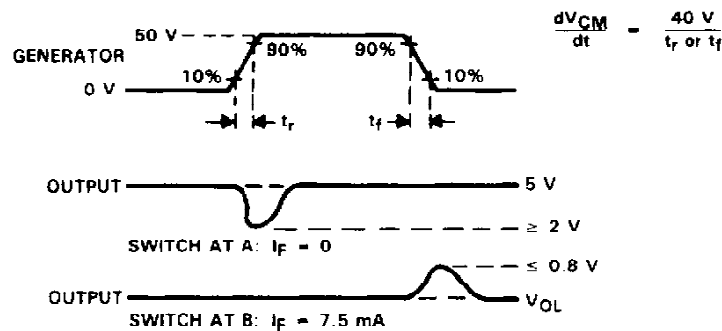

VOLTAGE WAVEFORMS

FIGURE 3. TRANSIENT IMMUNITY TEST CIRCUIT AND WAVEFORMS

TYPICAL APPLICATION INFORMATION

A ceramic capacitor (0.01 μF to 0.1 μF) should be connected between pins 8 and 5 to stabilize the high-gain amplifier. The total lead length between the capacitor and the optocoupler should not exceed 20 mm (0.8 inches). Failure to provide a bypass capacitor may result in impaired switching characteristics.

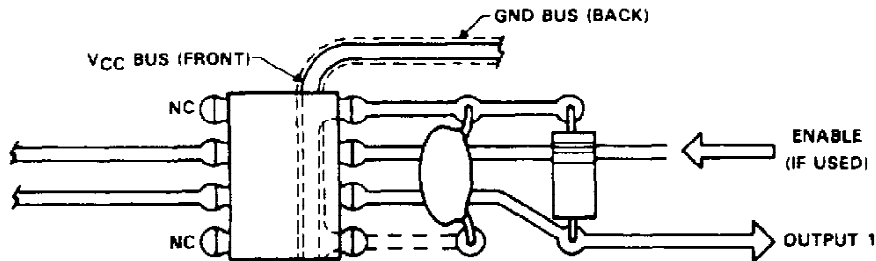

FIGURE 4. RECOMMENDED PRINTED CIRCUIT BOARD LAYOUT

**HCPL2601
OPTOCOUPLER/OPTOISOLATOR**

TYPICAL CHARACTERISTICS

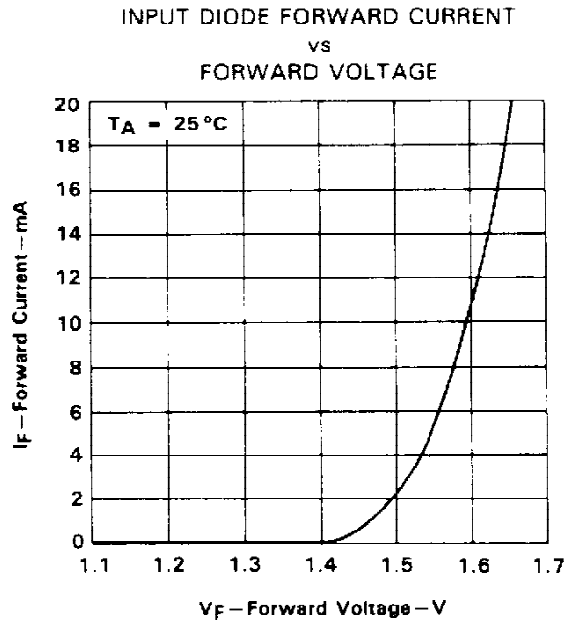

FIGURE 5

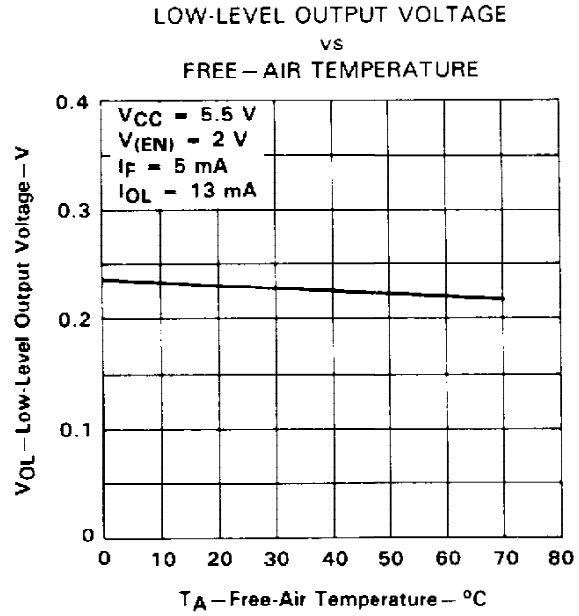

FIGURE 6

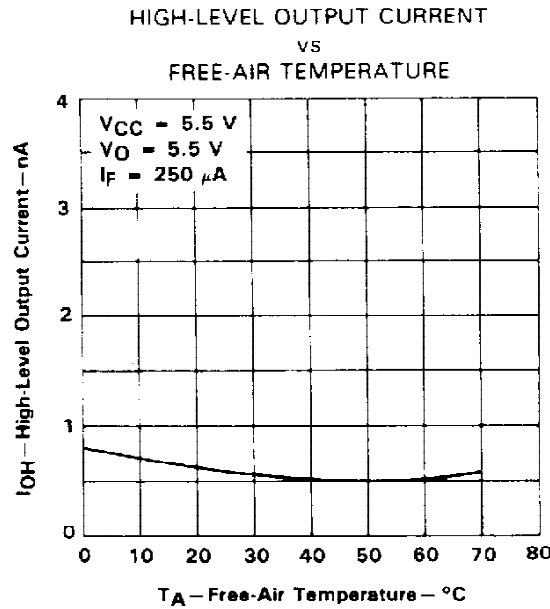

FIGURE 7

TYPICAL CHARACTERISTICS

PROPAGATION DELAY TIME FROM LED INPUT
vs
PULSE FORWARD CURRENT

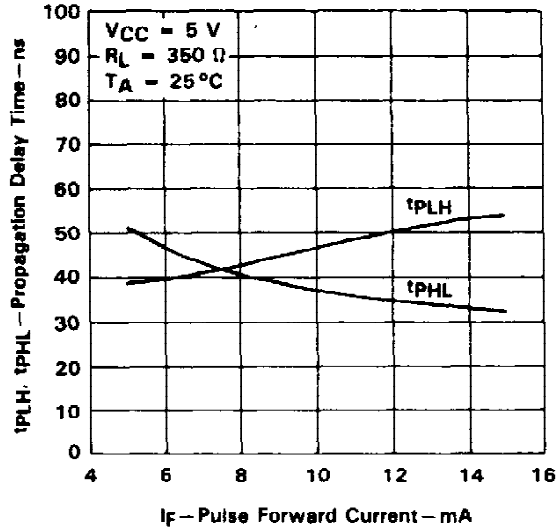

FIGURE 8

PROPAGATION DELAY TIME FROM LED INPUT
vs
LOAD RESISTANCE

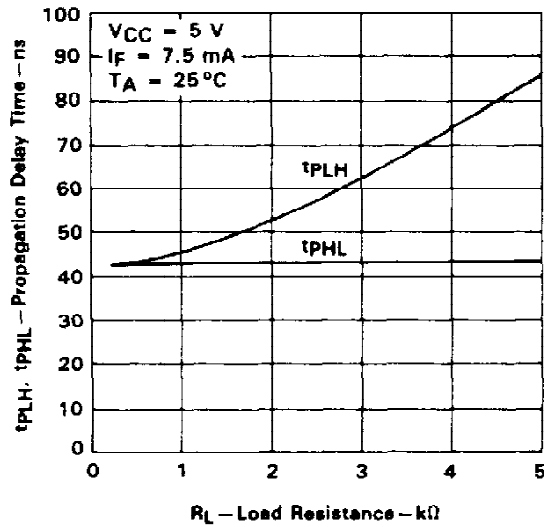

FIGURE 9

IMPORTANT NOTICE

Texas Instruments (TI) reserves the right to make changes to its products or to discontinue any semiconductor product or service without notice, and advises its customers to obtain the latest version of relevant information to verify, before placing orders, that the information being relied on is current.

TI warrants performance of its semiconductor products and related software to the specifications applicable at the time of sale in accordance with TI's standard warranty. Testing and other quality control techniques are utilized to the extent TI deems necessary to support this warranty. Specific testing of all parameters of each device is not necessarily performed, except those mandated by government requirements.

Certain applications using semiconductor products may involve potential risks of death, personal injury, or severe property or environmental damage ("Critical Applications").

TI SEMICONDUCTOR PRODUCTS ARE NOT DESIGNED, INTENDED, AUTHORIZED, OR WARRANTED TO BE SUITABLE FOR USE IN LIFE-SUPPORT APPLICATIONS, DEVICES OR SYSTEMS OR OTHER CRITICAL APPLICATIONS.

Inclusion of TI products in such applications is understood to be fully at the risk of the customer. Use of TI products in such applications requires the written approval of an appropriate TI officer. Questions concerning potential risk applications should be directed to TI through a local SC sales office.

In order to minimize risks associated with the customer's applications, adequate design and operating safeguards should be provided by the customer to minimize inherent or procedural hazards.

TI assumes no liability for applications assistance, customer product design, software performance, or infringement of patents or services described herein. Nor does TI warrant or represent that any license, either express or implied, is granted under any patent right, copyright, mask work right, or other intellectual property right of TI covering or relating to any combination, machine, or process in which such semiconductor products or services might be or are used.

IMPORTANT NOTICE

Texas Instruments and its subsidiaries (TI) reserve the right to make changes to their products or to discontinue any product or service without notice, and advise customers to obtain the latest version of relevant information to verify, before placing orders, that information being relied on is current and complete. All products are sold subject to the terms and conditions of sale supplied at the time of order acknowledgement, including those pertaining to warranty, patent infringement, and limitation of liability.

TI warrants performance of its semiconductor products to the specifications applicable at the time of sale in accordance with TI's standard warranty. Testing and other quality control techniques are utilized to the extent TI deems necessary to support this warranty. Specific testing of all parameters of each device is not necessarily performed, except those mandated by government requirements.

CERTAIN APPLICATIONS USING SEMICONDUCTOR PRODUCTS MAY INVOLVE POTENTIAL RISKS OF DEATH, PERSONAL INJURY, OR SEVERE PROPERTY OR ENVIRONMENTAL DAMAGE ("CRITICAL APPLICATIONS"). TI SEMICONDUCTOR PRODUCTS ARE NOT DESIGNED, AUTHORIZED, OR WARRANTED TO BE SUITABLE FOR USE IN LIFE-SUPPORT DEVICES OR SYSTEMS OR OTHER CRITICAL APPLICATIONS. INCLUSION OF TI PRODUCTS IN SUCH APPLICATIONS IS UNDERSTOOD TO BE FULLY AT THE CUSTOMER'S RISK.

In order to minimize risks associated with the customer's applications, adequate design and operating safeguards must be provided by the customer to minimize inherent or procedural hazards.

TI assumes no liability for applications assistance or customer product design. TI does not warrant or represent that any license, either express or implied, is granted under any patent right, copyright, mask work right, or other intellectual property right of TI covering or relating to any combination, machine, or process in which such semiconductor products or services might be or are used. TI's publication of information regarding any third party's products or services does not constitute TI's approval, warranty or endorsement thereof.