



Wide Input Range, No R_{SENSE}TM Positive-to-Negative DC/DC Controller

December 2001

FEATURES

- High Efficiency Operation (No Sense Resistor Required)
- Wide Input Voltage Range: 2.5V to 36V
- Current Mode Control Provides Excellent Transient Response
- High Maximum Duty Cycle (Typ 92%)
- ±2% RUN Pin Threshold with 100mV Hysteresis
- ±1% Internal Voltage Reference
- Micropower Shutdown: I_Q = 10µA
- Programmable Operating Frequency (50kHz to 1MHz) with One External Resistor
- Synchronizable to an External Clock Up to 1.3 × f_{OSC}
- User-Controlled Pulse Skip or Burst Mode[®] Operation
- Internal 5.2V Low Dropout Voltage Regulator
- Capable of Operating with a Sense Resistor for High Output Voltage Applications
- Small 10-Lead MSOP Package

APPLICATIONS

- Telecom Power Supplies
- Portable Electronic Equipment
- Cable and DSL Modems
- Router Supplies

DESCRIPTION

The LTC[®]3704 is a wide input range, current mode, positive-to-negative DC/DC controller that drives an N-channel power MOSFET and requires very few external components. Intended for low to high power applications, it eliminates the need for a current sense resistor by utilizing the power MOSFET's on-resistance, thereby maximizing efficiency.

The IC's operating frequency can be set with an external resistor over a 50kHz to 1MHz range, and can be synchronized to an external clock using the MODE/SYNC pin. Burst Mode operation at light loads, a low minimum operating supply voltage of 2.5V and a low shutdown quiescent current of 10µA make the LTC3704 ideally suited for battery-operated systems.

For applications requiring constant frequency operation, the Burst Mode operation feature can be defeated using the MODE/SYNC pin. Higher than 36V switch voltage applications are possible with the LTC3704 by connecting the SENSE pin to a resistor in the source of the power MOSFET.

The LTC3704 is available in the 10-lead MSOP package.

LT, LTC and LT are registered trademarks of Linear Technology Corporation.
Burst Mode is a registered trademark of Linear Technology Corporation.
R_{SENSE} is a trademark of Linear Technology Corporation.

TYPICAL APPLICATION

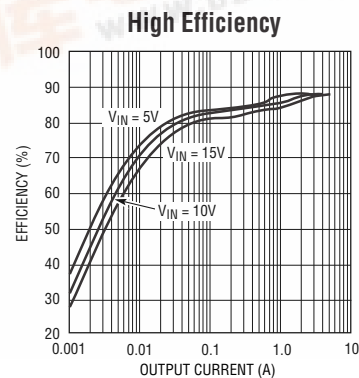
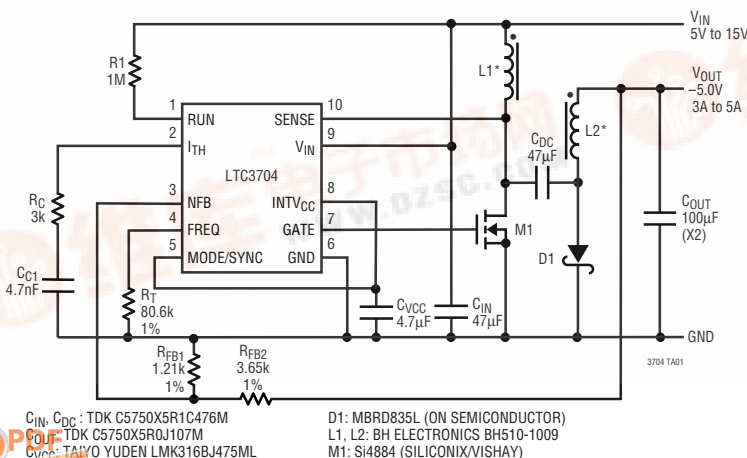

Figure 1. High Efficiency Positive to Negative Supply

C_{IN}, C_{CD}: TDK C5750X5R1C476M
C_{OUT}: TDK C5750X5R0J107M
C_{VCC}: TAIYO YUDEN LMK316BJ475ML
D1: MBRD835L (ON SEMICONDUCTOR)
L1, L2: BH ELECTRONICS BH510-1009
M1: Si4884 (SILICONIX/VISHAY)

3704 TA01b

LTC3704

ABSOLUTE MAXIMUM RATINGS

(Note 1)

V_{IN} Voltage	-0.3V to 36V
$INTV_{CC}$ Voltage	-0.3V to 7V
$INTV_{CC}$ Output Current	50mA
GATE Voltage	-0.3V to $V_{INTV_{CC}} + 0.3V$
I_{TH} Voltage	-0.3V to 2.7V
NFB Voltage	-2.7V to 2.7V
RUN, MODE/SYNC Voltages	-0.3V to 7V
FREQ Voltage	-0.3V to 1.5V
SENSE Pin Voltage	-0.3V to 36V
Operating Temperature Range (Note 2)	-40°C to 85°C
Junction Temperature (Note 3)	125°C
Storage Temperature Range	-65°C to 150°C
Lead Temperature (Soldering, 10 sec)	300°C

PACKAGE/ORDER INFORMATION

	ORDER PART NUMBER
	LTC3704EMS
	MS PART MARKING
	LTYT

Consult LTC Marketing for parts specified with wider operating temperature ranges.

ELECTRICAL CHARACTERISTICS

The ● denotes specifications which apply over the full operating temperature range, otherwise specifications are at $T_A = 25^\circ\text{C}$.

$V_{IN} = V_{INTV_{CC}} = 5V$, $V_{RUN} = 1.5V$, $R_T = 80k$, $V_{MODE/SYNC} = 0V$, unless otherwise specified.

SYMBOL	PARAMETER	CONDITIONS	MIN	TYP	MAX	UNITS
Main Control Loop						
$V_{IN(MIN)}$	Minimum Input Voltage		2.5			V
I_Q	Input Voltage Supply Current	(Note 4)				
	Continuous Mode	$V_{MODE/SYNC} = 5V$, $V_{ITH} = 0.75V$		550	1000	μA
	Burst Mode Operation, No Load	$V_{MODE/SYNC} = 0V$, $V_{ITH} = 0.2V$ (Note 5)		250	500	μA
	Shutdown Mode	$V_{RUN} = 0V$		10	20	μA
V_{RUN}^+	Rising RUN Input Threshold Voltage			1.348		V
V_{RUN}^-	Falling RUN Input Threshold Voltage		1.223	1.248	1.273	V
		●	1.198		1.298	V
$V_{RUN(HYST)}$	RUN Pin Input Threshold Hysteresis		50	100	150	mV
I_{RUN}	RUN Input Current			1	100	nA
V_{NFB}	Negative Feedback Voltage	$V_{ITH} = 0.2V$ (Note 5)	-1.218	-1.230	-1.242	V
		●	-1.212		-1.248	V
I_{NFB}	NFB Pin Input Current	$V_{ITH} = 0.2V$ (Note 5)		7.5	15	μA
$\frac{\Delta V_{NFB}}{\Delta V_{IN}}$	Line Regulation	$2.5V \leq V_{IN} \leq 30V$		0.002	0.02	%/V
$\frac{\Delta V_{NFB}}{\Delta V_{ITH}}$	Load Regulation	$V_{MODE/SYNC} = 0V$, $V_{TH} = 0.5V$ to $0.90V$ (Note 5)	●	-1	-0.1	%
g_m	Error Amplifier Transconductance	I_{TH} Pin Load = $\pm 5\mu\text{A}$ (Note 5)		650		μmho
$V_{ITH(BURST)}$	Burst Mode Operation I_{TH} Pin Voltage	Falling I_{TH} Voltage (Note 5)		0.3		V
$V_{SENSE(MAX)}$	Maximum Current Sense Input Threshold	Duty Cycle < 20%	120	150	180	mV
$I_{SENSE(ON)}$	SENSE Pin Current (GATE High)	$V_{SENSE} = 0V$		40	75	μA
$I_{SENSE(OFF)}$	SENSE Pin Current (GATE Low)	$V_{SENSE} = 30V$		0.1	5	μA

ELECTRICAL CHARACTERISTICS

The ● denotes specifications which apply over the full operating temperature range, otherwise specifications are at $T_A = 25^\circ\text{C}$.

$V_{IN} = V_{INTVCC} = 5V$, $V_{RUN} = 1.5V$, $R_{FREQ} = 80k$, $V_{MODE/SYNC} = 0V$, unless otherwise specified.

SYMBOL	PARAMETER	CONDITIONS	MIN	TYP	MAX	UNITS
Oscillator						
f_{OSC}	Oscillator Frequency	$R_{FREQ} = 80k$	250	300	350	kHz
	Oscillator Frequency Range		50		1000	kHz
D_{MAX}	Maximum Duty Cycle		87	92	97	%
f_{SYNC}/f_{OSC}	Recommended Maximum Synchronized Frequency Ratio	$f_{OSC} = 300kHz$ (Note 6)		1.25	1.30	
$t_{SYNC(MIN)}$	MODE/SYNC Minimum Input Pulse Width	$V_{SYNC} = 0V$ to $5V$		25		ns
$t_{SYNC(MAX)}$	MODE/SYNC Maximum Input Pulse Width	$V_{SYNC} = 0V$ to $5V$		$0.8/f_{OSC}$		ns
$V_{IL(MODE)}$	Low Level MODE/SYNC Input Voltage				0.3	V
$V_{IH(MODE)}$	High Level MODE/SYNC Input Voltage		1.2			V
$R_{MODE/SYNC}$	MODE/SYNC Input Pull-Down Resistance			50		k Ω
V_{FREQ}	Nominal FREQ Pin Voltage			0.62		V
Low Dropout Regulator						
V_{INTVCC}	INTV _{CC} Regulator Output Voltage	$V_{IN} = 7.5V$	5.0	5.2	5.4	V
$\frac{\Delta V_{INTVCC}}{\Delta V_{IN1}}$	INTV _{CC} Regulator Line Regulation	$7.5V \leq V_{IN} \leq 15V$		8	25	mV
$\frac{\Delta V_{INTVCC}}{\Delta V_{IN2}}$	INTV _{CC} Regulator Line Regulation	$15V \leq V_{IN} \leq 30V$		70	200	mV
$V_{LDO(LOAD)}$	INTV _{CC} Load Regulation	$0 \leq I_{INTVCC} \leq 20mA$	-2	-0.2		%
$V_{DROPOUT}$	INTV _{CC} Regulator Dropout Voltage	$V_{IN} = 5V$, INTV _{CC} Load = 20mA		280		mV
I_{INTVCC}	Bootstrap Mode INTV _{CC} Supply Current in Shutdown	RUN = 0V, SENSE = 5V		10	20	μA
GATE Driver						
t_r	GATE Driver Output Rise Time	$C_L = 3300pF$ (Note 7)		17	100	ns
t_f	GATE Driver Output Fall Time	$C_L = 3300pF$ (Note 7)		8	100	ns

Note 1: Absolute Maximum Ratings are those values beyond which the life of the device may be impaired.

Note 2: The LTC3704E is guaranteed to meet performance specifications from 0°C to 70°C . Specifications over the -40°C to 85°C operating temperature range are assured by design, characterization and correlation with statistical process controls.

Note 3: T_J is calculated from the ambient temperature T_A and power dissipation P_D according to the following formula:

$$T_J = T_A + (P_D \cdot 120^\circ\text{C/W})$$

Note 4: The dynamic input supply current is higher due to power MOSFET gate charging ($Q_G \cdot f_{OSC}$). See Applications Information.

Note 5: The LTC3704 is tested in a feedback loop that servos V_{NFB} to the reference voltage with the I_{TH} pin forced to a voltage between $0V$ and $1.4V$ (the no load to full load operating voltage range for the I_{TH} pin is $0.3V$ to $1.23V$).

Note 6: In a synchronized application, the internal slope compensation gain is increased by 25%. Synchronizing to a significantly higher ratio will reduce the effective amount of slope compensation, which could result in subharmonic oscillation for duty cycles greater than 50%.

Note 7: Rise and fall times are measured at 10% and 90% levels.

PIN FUNCTIONS

RUN (Pin 1): The RUN pin provides the user with an accurate means for sensing the input voltage and programming the start-up threshold for the converter. The falling RUN pin threshold is nominally 1.248V and the comparator has 100mV of hysteresis for noise immunity. When the RUN pin is below this input threshold, the IC is shut down and the V_{IN} supply current is kept to a low value (typ 10 μ A). The Absolute Maximum Rating for the voltage on this pin is 7V.

I_{TH} (Pin 2): Error Amplifier Compensation Pin. The current comparator input threshold increases with this control voltage. Nominal voltage range for this pin is 0V to 1.40V.

NFB (Pin 3): Receives the feedback voltage from the external resistor divider across the output. Nominal voltage for this pin in regulation is -1.230V.

FREQ (Pin 4): A resistor from the FREQ pin to ground programs the operating frequency of the chip. The nominal voltage at the FREQ pin is 0.62V.

MODE/SYNC (Pin 5): This input controls the operating mode of the converter and allows for synchronizing the

operating frequency to an external clock. If the MODE/SYNC pin is connected to ground, Burst Mode operation is enabled. If the MODE/SYNC pin is connected to INTV_{CC}, or if an external logic-level synchronization signal is applied to this input, Burst Mode operation is disabled and the IC operates in a continuous mode.

GND (Pin 6): Ground Pin.

GATE (Pin 7): Gate Driver Output.

INTV_{CC} (Pin 8): The Internal 5.20V Regulator Output. The gate driver and control circuits are powered from this voltage. Decouple this pin locally to the IC ground with a minimum of 4.7 μ F low ESR tantalum or ceramic capacitor.

V_{IN} (Pin 9): Main Supply Pin. Must be closely decoupled to ground.

SENSE (Pin 10): The Current Sense Input for the Control Loop. Connect this pin to the drain of the power MOSFET for V_{DS} sensing and highest efficiency. Alternatively, the SENSE pin may be connected to a resistor in the source of the power MOSFET. Internal leading edge blanking is provided for both sensing methods.

BLOCK DIAGRAM

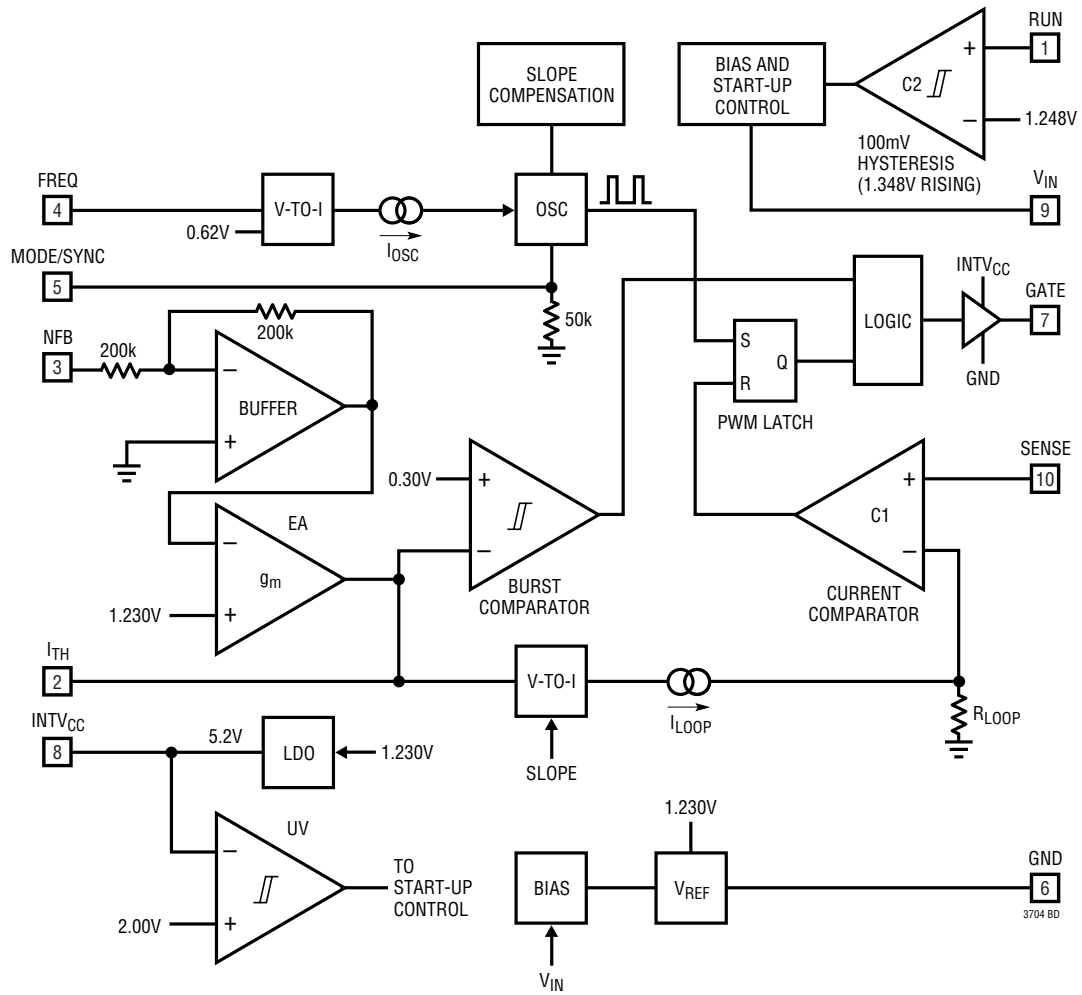

LTC3704

OPERATION

Main Control Loop

The LTC3704 is a constant frequency, current mode controller for DC/DC positive-to-negative converter applications. The LTC3704 is distinguished from conventional current mode controllers because the current control loop can be closed by sensing the voltage drop across the power MOSFET switch instead of across a discrete sense resistor, as shown in Figure 2. This sensing technique improves efficiency, increases power density, and reduces the cost of the overall solution.

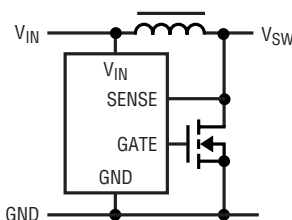

2a. SENSE Pin Connection for Maximum Efficiency ($V_{SW} < 36V$)

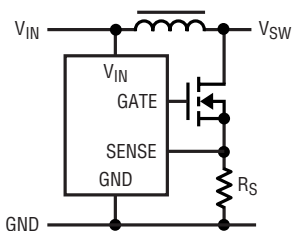

2b. SENSE Pin Connection for Precise Control of Peak I_{IN}/I_{OUT} or for $V_{SW} > 36V$

Figure 2. Using the SENSE Pin On the LTC3704

For circuit operation, please refer to the Block Diagram of the IC and Figure 1. In normal operation, the power MOSFET is turned on when the oscillator sets the PWM latch and is turned off when the current comparator C1 resets the latch. The divided-down output voltage is compared to an internal 1.230V reference by the error amplifier EA, which outputs an error signal at the I_{TH} pin. The voltage on the I_{TH} pin sets the current comparator C1 input threshold. When the load current increases, a fall in the NFB voltage relative to the reference voltage causes the I_{TH} pin to rise, which causes the current comparator C1 to trip at a higher peak inductor current value. The average inductor current will therefore rise until it equals the load current, thereby maintaining output regulation.

The nominal operating frequency of the LTC3704 is programmed using a resistor from the FREQ pin to ground and can be controlled over a 50kHz to 1000kHz range. In addition, the internal oscillator can be synchronized to an external clock applied to the MODE/SYNC pin and can be locked to a frequency between 100% and 130% of its nominal value. When the MODE/SYNC pin is left open, it is pulled low by an internal 50k resistor and Burst Mode operation is enabled. If this pin is taken above 2V or an external clock is applied, Burst Mode operation is disabled and the IC operates in continuous mode. With no load (or an extremely light load), the controller will skip pulses in order to maintain regulation and prevent excessive output ripple.

The RUN pin controls whether the IC is enabled or is in a low current shutdown state. A micropower 1.248V reference and comparator C2 allow the user to program the supply voltage at which the IC turns on and off (comparator C2 has 100mV of hysteresis for noise immunity). With the RUN pin below 1.248V, the chip is off and the input supply current is typically only 10 μ A.

The LTC3704 can be used either by sensing the voltage drop across the power MOSFET or by connecting the SENSE pin to a conventional shunt resistor in the source of the power MOSFET, as shown in Figure 2. Sensing the voltage across the power MOSFET maximizes converter efficiency and minimizes the component count, but limits the output voltage to the maximum rating for this pin (36V). By connecting the SENSE pin to a resistor in the source of the power MOSFET, the user is able to program output voltages significantly greater than the 36V maximum input voltage rating for the IC.

Programming the Operating Mode

For applications where maximizing the efficiency at very light loads (e.g., <100 μ A) is a high priority, Burst Mode operation should be applied (i.e., the MODE/SYNC pin should be connected to ground). In applications where fixed frequency operation is more critical than low current efficiency, or where the lowest output ripple is desired, pulse-skip mode operation should be used and the MODE/SYNC pin should be connected to the INTV_{CC} pin. This allows discontinuous conduction mode (DCM) operation down to near the limit defined by the chip's

OPERATION

minimum on-time (about 175ns). Below this output current level, the converter will begin to skip cycles in order to maintain output regulation. Figures 3 and 4 show the light load switching waveforms for Burst Mode and Pulse-Skip Mode operation for the converter in Figure 1.

Burst Mode Operation

Burst Mode operation is selected by leaving the MODE/SYNC pin unconnected or by connecting it to ground. In normal operation, the range on the I_{TH} pin corresponding to no load to full load is 0.30V to 1.2V. In Burst Mode operation, if the error amplifier EA drives the I_{TH} voltage below 0.525V, the buffered I_{TH} input to the current comparator C1 will be clamped at 0.525V (which corresponds to 25% of maximum load current). The inductor current peak is then held at approximately 30mV divided by the power MOSFET $R_{DS(ON)}$. If the I_{TH} pin drops below 0.30V, the Burst Mode comparator B1 will turn off the power MOSFET and scale back the quiescent current of the IC to 250 μ A (sleep mode). In this condition, the load current will be supplied by the output capacitor until the I_{TH} voltage rises above the 50mV hysteresis of the burst comparator. At light loads, short bursts of switching (where the average inductor current is 25% of its maximum value) followed by long periods of sleep will be observed, thereby greatly improving converter efficiency. Oscilloscope waveforms illustrating Burst Mode operation are shown in Figure 3.

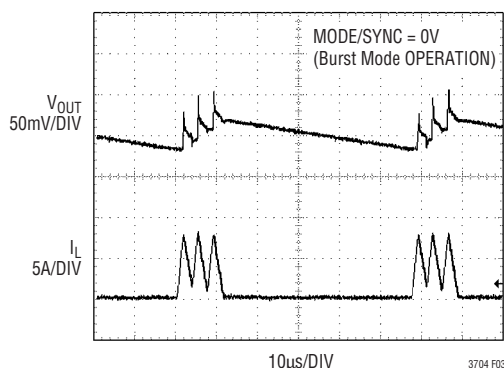

Figure 3. LTC3704 Burst Mode Operation (MODE/SYNC = 0V) at Low Output Current

Pulse-Skip Mode Operation

With the MODE/SYNC pin tied to a DC voltage above 2V, Burst Mode operation is disabled. The internal, 0.525V

buffered I_{TH} burst clamp is removed, allowing the I_{TH} pin to directly control the current comparator from no load to full load. With no load, the I_{TH} pin is driven below 0.30V, the power MOSFET is turned off and sleep mode is invoked. Oscilloscope waveforms illustrating this mode of operation are shown in Figure 4.

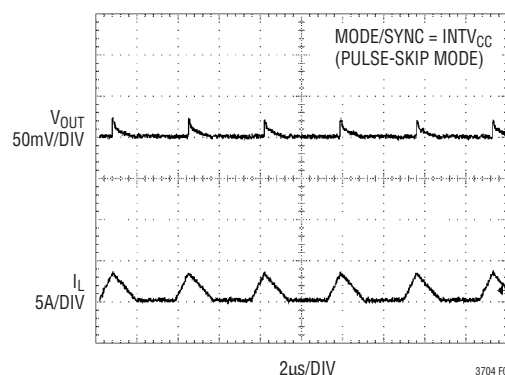

Figure 4. LTC3704 Low Output Current Operation with Burst Mode Operation Disabled (MODE/SYNC = INTVCC)

When an external clock signal drives the MODE/SYNC pin at a rate faster than the chip's internal oscillator, the oscillator will synchronize to it. In this synchronized mode, Burst Mode operation is disabled. The constant frequency associated with synchronized operation provides a more controlled noise spectrum from the converter, at the expense of overall system efficiency of light loads.

When the oscillator's internal logic circuitry detects a synchronizing signal on the MODE/SYNC pin, the internal oscillator ramp is terminated early and the slope compensation is increased by approximately 30%. As a result, in applications requiring synchronization, it is recommended that the nominal operating frequency of the IC be programmed to be about 75% of the external clock frequency. Attempting to synchronize to too high an external frequency (above $1.3f_0$) can result in inadequate slope compensation and possible subharmonic oscillation (or jitter).

The external clock signal must exceed 2V for at least 25ns, and should have a maximum duty cycle of 80%, as shown in Figure 5. The MOSFET turn on will synchronize to the rising edge of the external clock signal.

APPLICATIONS INFORMATION

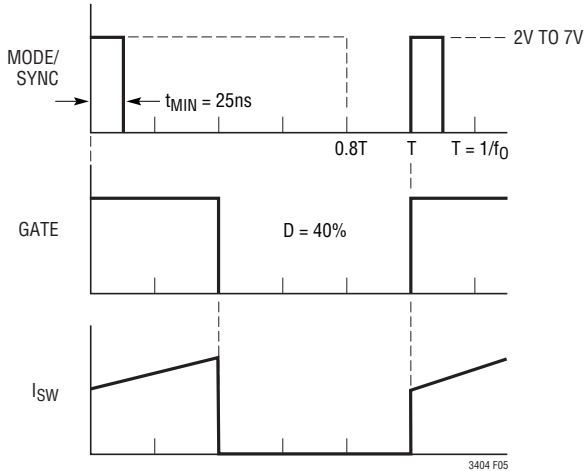

Figure 5. MODE/SYNC Clock Input and Switching Waveforms for Synchronized Operation

Programming the Operating Frequency

The choice of operating frequency and inductor value is a tradeoff between efficiency and component size. Low frequency operation improves efficiency by reducing MOSFET and diode switching losses. However, lower frequency operation requires more inductance for a given amount of load current.

The LTC3704 uses a constant frequency architecture that can be programmed over a 50kHz to 1000kHz range with a single external resistor from the FREQ pin to ground, as shown in Figure 1. The nominal voltage on the FREQ pin is 0.6V, and the current that flows into the FREQ pin is used to charge and discharge an internal oscillator capacitor. A graph for selecting the value of R_T for a given operating frequency is shown in Figure 6.

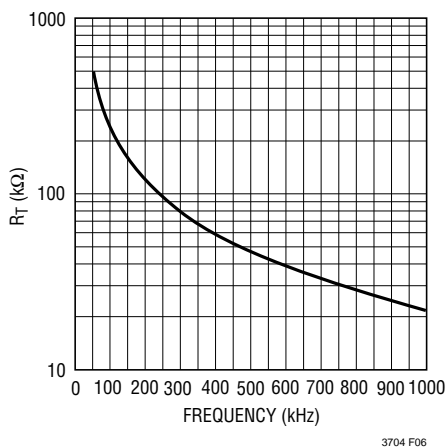

Figure 6. Timing Resistor (R_T) Value

INTV_{CC} Regulator Bypassing and Operation

An internal, P-channel low dropout voltage regulator produces the 5.2V supply which powers the gate driver and logic circuitry within the LTC3704, as shown in Figure 7. The INTV_{CC} regulator can supply up to 50mA and must be bypassed to ground immediately adjacent to the IC pins with a minimum of 4.7μF tantalum or ceramic capacitor. Good bypassing is necessary to supply the high transient currents required by the MOSFET gate driver.

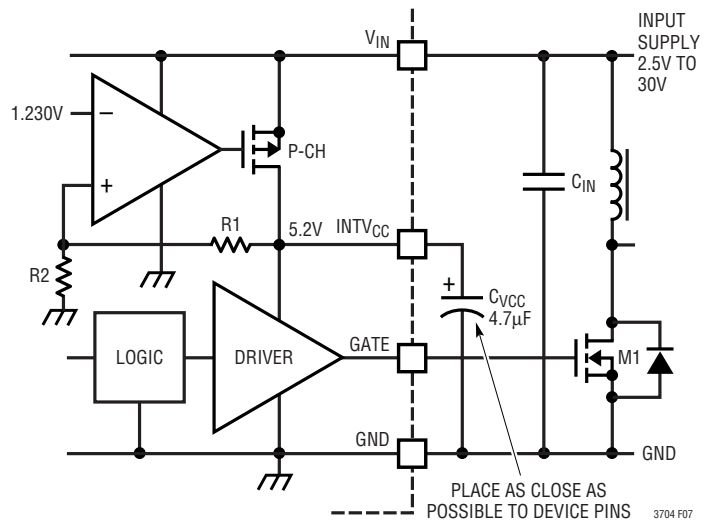

Figure 7. Bypassing the LDO Regulator and Gate Driver Supply

For input voltages that don't exceed 7V (the absolute maximum rating for this pin), the internal low dropout regulator in the LTC3704 is redundant and the INTV_{CC} pin can be shorted directly to the V_{IN} pin. With the INTV_{CC} pin shorted to V_{IN}, however, the divider that programs the regulated INTV_{CC} voltage will draw 10μA of current from the input supply, even in shutdown mode. For applications that require the lowest shutdown mode input supply current, do not connect the INTV_{CC} pin to V_{IN}. Regardless of whether the INTV_{CC} pin is shorted to V_{IN} or not, **it is always necessary to have the driver circuitry bypassed with a 4.7μF tantalum or low ESR ceramic capacitor to ground immediately adjacent to the INTV_{CC} and GND pins.**

In an actual application, most of the IC supply current is used to drive the gate capacitance of the power MOSFET. As a result, high input voltage applications in which a large power MOSFET is being driven at high frequencies can

APPLICATIONS INFORMATION

cause the LTC3704 to exceed its maximum junction temperature rating. The junction temperature can be estimated using the following equations:

$$I_{Q(TOT)} \approx I_Q + f \cdot Q_G$$

$$P_{IC} = V_{IN} \cdot (I_Q + f \cdot Q_G)$$

$$T_J = T_A + P_{IC} \cdot R_{TH(JA)}$$

The total quiescent current $I_{Q(TOT)}$ consists of the static supply current (I_Q) and the current required to charge and discharge the gate of the power MOSFET. The 10-pin MSOP package has a thermal resistance of $R_{TH(JA)} = 120^\circ\text{C/W}$.

As an example, consider a power supply with $V_{IN} = 5\text{V}$ and $V_{SW(MAX)} = 12\text{V}$. The switching frequency is 500kHz , and the maximum ambient temperature is 70°C . The power MOSFET chosen is the IRF7805, which has a maximum $R_{DS(ON)}$ of $11\text{m}\Omega$ (at room temperature) and a maximum total gate charge of 37nC (the temperature coefficient of the gate charge is low).

$$I_{Q(TOT)} = 600\mu\text{A} + 37\text{nC} \cdot 500\text{kHz} = 19.1\text{mA}$$

$$P_{IC} = 5\text{V} \cdot 19.1\text{mA} = 95\text{mW}$$

$$T_J = 70^\circ\text{C} + 120^\circ\text{C/W} \cdot 95\text{mW} = 81.4^\circ\text{C}$$

This demonstrates how significant the gate charge current can be when compared to the static quiescent current in the IC.

To prevent the maximum junction temperature from being exceeded, the input supply current must be checked when operating in a continuous mode at high V_{IN} . A tradeoff between the operating frequency and the size of the power MOSFET may need to be made in order to maintain a reliable IC junction temperature. Prior to lowering the operating frequency, however, be sure to check with power MOSFET manufacturers for their latest-and-greatest low Q_G , low $R_{DS(ON)}$ devices. Power MOSFET manufacturing technologies are continually improving, with newer and better performance devices being introduced almost yearly.

Output Voltage Programming

The output voltage is set by a resistor divider according to the following formula:

$$V_O = V_{REF} \cdot \left(1 + \frac{R_2}{R_1} \right) + I_{NFB} \cdot R_2$$

where $V_{REF} = -1.230\text{V}$, and I_{NFB} is the current which flows out of the NFB pin ($I_{NFB} = -7.5\mu\text{A}$). In order to properly dimension R_2 , including the effect of the NFB pin current, the following formula can be used:

$$R_2 = \frac{V_{OUT} - V_{REF}}{\left(\frac{V_{REF}}{R_1} + I_{NFB} \right)}$$

The nominal $7.5\mu\text{A}$ current which flows out of the NFB pin has a production tolerance of approximately $\pm 2.5\mu\text{A}$, so an output divider current of $500\mu\text{A}$ ($R_1 = 2.49\text{k}$) results in a 0.5% uncertainty in the output voltage. For low power applications where the output voltage tolerance is less important, efficiency can be increased by increasing the value of R_1 .

Programming Turn-On and Turn-Off Thresholds with the RUN Pin

The LTC3704 contains an independent, micropower voltage reference and comparator detection circuit that remains active even when the device is shut down, as shown in Figure 8. This allows users to accurately program an input voltage at which the converter will turn on and off. The falling threshold voltage on the RUN pin is equal to the internal reference voltage of 1.248V . The comparator has 100mV of hysteresis to increase noise immunity.

The turn-on and turn-off input voltage thresholds are programmed using a resistor divider according to the following formulas:

APPLICATIONS INFORMATION

$$V_{IN(OFF)} = 1.248V \cdot \left(1 + \frac{R2}{R1}\right)$$

$$V_{IN(ON)} = 1.348V \cdot \left(1 + \frac{R2}{R1}\right)$$

The resistor R1 is typically chosen to be less than 1M.

For applications where the RUN pin is only to be used as a logic input, the user should be aware of the 7V Absolute Maximum Rating for this pin! The RUN pin can be connected to the input voltage through an external 1M resistor, as shown in Figure 8c, for “always on” operation.

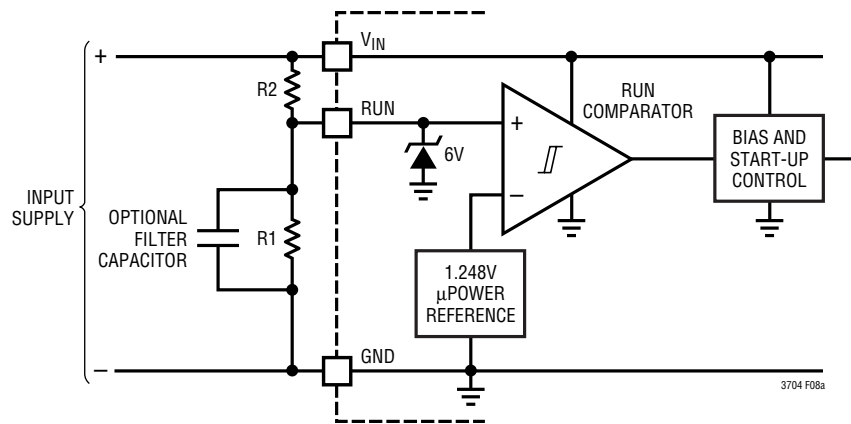

Figure 8a. Programming the Turn-On and Turn-Off Thresholds Using the RUN Pin

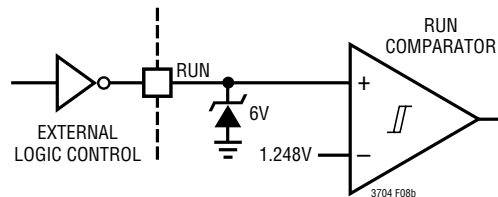

Figure 8b. On/Off Control Using External Logic

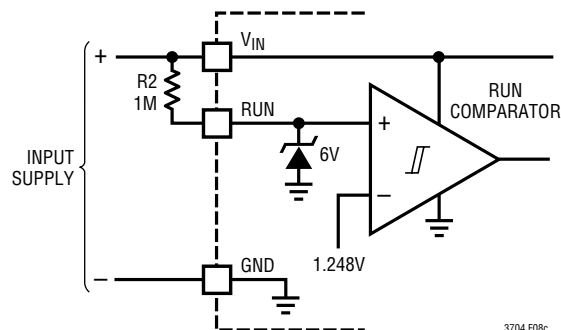
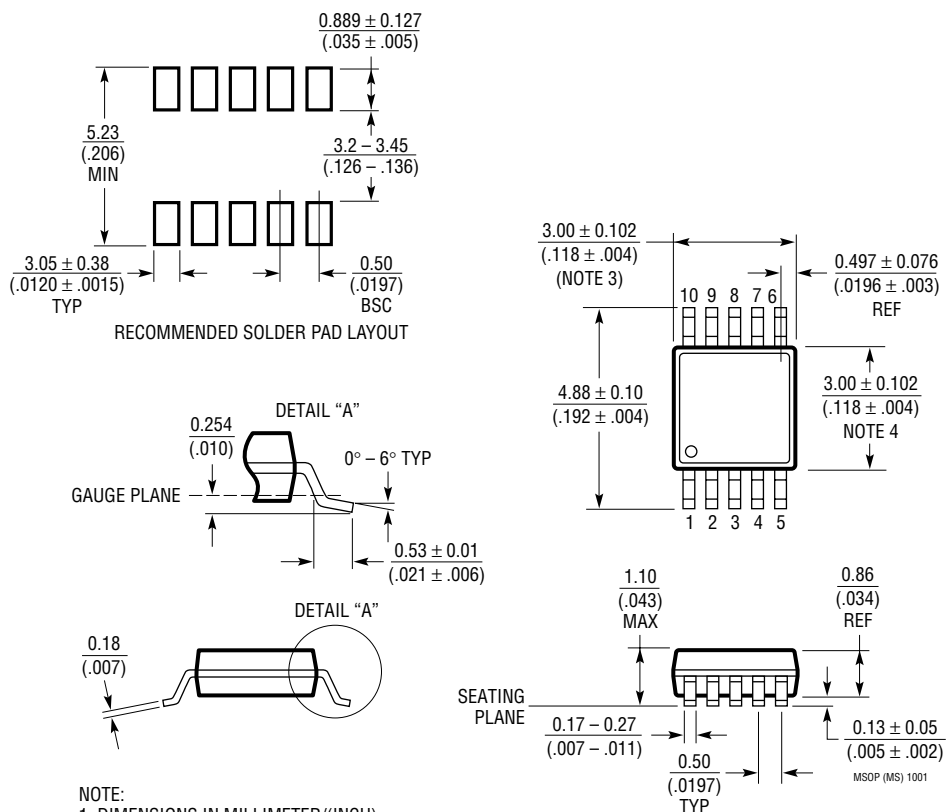

Figure 8c. External Pull-Up Resistor On RUN Pin for “Always On” Operation

PACKAGE DESCRIPTION

MS Package
10-Lead Plastic MSOP
 (Reference LTC DWG # 05-08-1661)



- NOTE:
1. DIMENSIONS IN MILLIMETER/(INCH)
 2. DRAWING NOT TO SCALE
 3. DIMENSION DOES NOT INCLUDE MOLD FLASH, PROTRUSIONS OR GATE BURRS.
MOLD FLASH, PROTRUSIONS OR GATE BURRS SHALL NOT EXCEED 0.152mm (.006") PER SIDE
 4. DIMENSION DOES NOT INCLUDE INTERLEAD FLASH OR PROTRUSIONS.
INTERLEAD FLASH OR PROTRUSIONS SHALL NOT EXCEED 0.152mm (.006") PER SIDE
 5. LEAD COPLANARITY (BOTTOM OF LEADS AFTER FORMING) SHALL BE 0.102mm (.004") MAX

LTC3704

TYPICAL APPLICATION

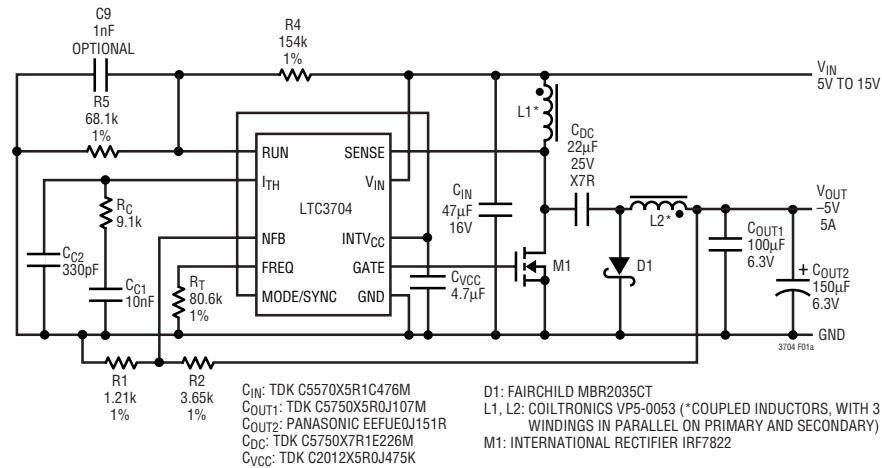

High Efficiency Positive-to-Negative Converter

RELATED PARTS

PART NUMBER	DESCRIPTION	COMMENTS
LT1175	Negative Linear Low Dropout Regulator	User-Selectable Current Limit from 200mA to 800mA, 0.4V Dropout at 500mA, 45µA Operating Current
LT [®] 1619	Current Mode PWM Controller	300kHz Fixed Frequency, Boost, SEPIC, Flyback Topology
LTC1624	Current Mode DC/DC Controller	SO-8; 300kHz Operating Frequency; Buck, Boost, SEPIC Design; V _{IN} Up to 36V
LTC1700	No R _{SENSE} Synchronous Step-Up Controller	Up to 95% Efficiency, Operation as Low as 0.9V Input
LTC1871	No R _{SENSE} Boost, Flyback and SEPIC Controller	2.5V ≤ V _{IN} ≤ 30V, Current Mode Control, Programmable f _{OSC} from 50kHz to 1MHz
LTC1872	SOT-23 Boost Controller	Delivers Up to 5A, 550kHz Fixed Frequency, Current Mode
LT1930	1.2MHz, SOT-23 Boost Converter	Up to 34V Output, 2.6V ≤ V _{IN} ≤ 16V, Miniature Design
LT1931	Inverting 1.2MHz, SOT-23 Converter	Positive-to-Negative DC/DC Conversion, Miniature Design
LT1964	ThinSOT™ Linear Low Dropout Regulator	200mA Output Current, Low Noise, 340mV Drop Out at 200mA, 5-Lead ThinSOT
LTC3401/LTC3402	1A/2A 3MHz Synchronous Boost Converters	Up to 97% Efficiency, Very Small Solution, 0.5V ≤ V _{IN} ≤ 5V

ThinSOT is a trademark of Linear Technology Corporation.