



March 1996

LM2587 SIMPLE SWITCHER® 5A Flyback Regulator

General Description

The LM2587 series of regulators are monolithic integrated circuits specifically designed for flyback, step-up (boost), and forward converter applications. The device is available in 4 different output voltage versions: 3.3V, 5.0V, 12V, and adjustable.

Requiring a minimum number of external components, these regulators are cost effective, and simple to use. Included in the datasheet are typical circuits of boost and flyback regulators. Also listed are selector guides for diodes and capacitors and a family of standard inductors and flyback transformers designed to work with these switching regulators.

The power switch is a 5.0A NPN device that can stand-off 65V. Protecting the power switch are current and thermal limiting circuits, and an undervoltage lockout circuit. This IC contains a 100 kHz fixed-frequency internal oscillator that permits the use of small magnetics. Other features include soft start mode to reduce in-rush current during start up, current mode control for improved rejection of input voltage and output load transients and cycle-by-cycle current limiting. An output voltage tolerance of $\pm 4\%$, within specified input voltages and output load conditions, is guaranteed for the power supply system.

Features

- Requires few external components
- Family of standard inductors and transformers
- NPN output switches 5.0A, can stand off 65V
- Wide input voltage range: 4V to 40V
- Current-mode operation for improved transient response, line regulation, and current limit
- 100 kHz switching frequency
- Internal soft-start function reduces in-rush current during start-up
- Output transistor protected by current limit, under voltage lockout, and thermal shutdown
- System Output Voltage Tolerance of $\pm 4\%$ max over line and load conditions

Typical Applications

- Flyback regulator
- Multiple-output regulator
- Simple boost regulator
- Forward converter

Flyback Regulator

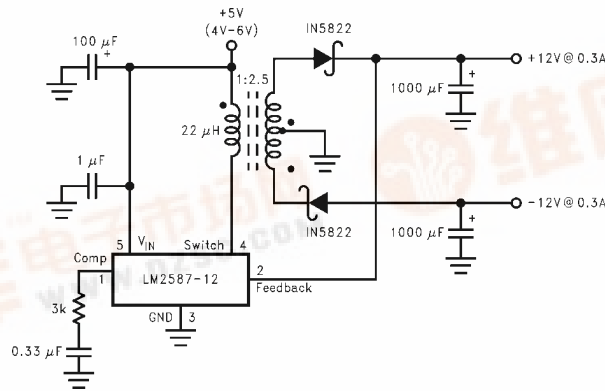

TL/H/12316-1

Ordering Information

Package Type	NSC Package Drawing	Order Number
5-Lead TO-220 Bent, Staggered Leads	T05D	LM2587T-3.3, LM2587T-5.0, LM2587T-12, LM2587T-ADJ
5-Lead TO-263	TS5B	LM2587S-3.3, LM2587S-5.0, LM2587S-12, LM2587S-ADJ
5-Lead TO-263 Tape and Reel	TS5B	LM2587SX-3.3, LM2587SX-5.0, LM2587SX-12, LM2587SX-ADJ

SIMPLE SWITCHER® and Switchers Made Simple® are registered trademarks of National Semiconductor Corporation.

LM2587 SIMPLE SWITCHER 5A Flyback Regulator



Absolute Maximum Ratings (Note 1)

If Military/Aerospace specified devices are required, please contact the National Semiconductor Sales Office/Distributors for availability and specifications.

Input Voltage	$-0.4V \leq V_{IN} \leq 45V$
Switch Voltage	$-0.4V \leq V_{SW} \leq 65V$
Switch Current (Note 2)	Internally Limited
Compensation Pin Voltage	$-0.4V \leq V_{COMP} \leq 2.4V$
Feedback Pin Voltage	$-0.4V \leq V_{FB} \leq 2 V_{OUT}$
Power Dissipation (Note 3)	Internally Limited

Storage Temperature Range	$-65^{\circ}C$ to $+150^{\circ}C$
Lead Temperature (Soldering, 10 sec.)	$260^{\circ}C$
Maximum Junction Temperature (Note 3)	$150^{\circ}C$
Minimum ESD Rating (C = 100 pF, R = 1.5 k Ω)	2 kV

Operating Ratings

Supply Voltage	$4V \leq V_{IN} \leq 40V$
Output Switch Voltage	$0V \leq V_{SW} \leq 60V$
Output Switch Current	$I_{SW} \leq 5.0A$
Junction Temperature Range	$-40^{\circ}C \leq T_J \leq +125^{\circ}C$

Electrical Characteristics

Specifications with standard type face are for $T_J = 25^{\circ}C$, and those in **bold type face** apply over full Operating Temperature Range. Unless otherwise specified, $V_{IN} = 5V$.

LM2587-3.3

Symbol	Parameters	Conditions	Typical	Min	Max	Units
SYSTEM PARAMETERS Test Circuit of Figure 2 (Note 4)						
V_{OUT}	Output Voltage	$V_{IN} = 4V$ to $12V$ $I_{LOAD} = 400$ mA to $1.75A$	3.3	3.17/ 3.14	3.43/ 3.46	V
$\Delta V_{OUT}/\Delta V_{IN}$	Line Regulation	$V_{IN} = 4V$ to $12V$ $I_{LOAD} = 400$ mA	20		50/ 100	mV
$\Delta V_{OUT}/\Delta I_{LOAD}$	Load Regulation	$V_{IN} = 12V$ $I_{LOAD} = 400$ mA to $1.75A$	20		50/ 100	mV
η	Efficiency	$V_{IN} = 12V$, $I_{LOAD} = 1A$	75			%
UNIQUE DEVICE PARAMETERS (Note 5)						
V_{REF}	Output Reference Voltage	Measured at Feedback Pin $V_{COMP} = 1.0V$	3.3	3.242/ 3.234	3.358/ 3.366	V
ΔV_{REF}	Reference Voltage Line Regulation	$V_{IN} = 4V$ to $40V$	2.0			mV
G_M	Error Amp Transconductance	$I_{COMP} = -30$ μA to $+30$ μA $V_{COMP} = 1.0V$	1.193	0.678	2.259	mmho
A_{VOL}	Error Amp Voltage Gain	$V_{COMP} = 0.5V$ to $1.6V$ $R_{COMP} = 1.0$ M Ω (Note 6)	260	151/ 75		V/V

LM2587-5.0

Symbol	Parameters	Conditions	Typical	Min	Max	Units
SYSTEM PARAMETERS Test Circuit of Figure 2 (Note 4)						
V_{OUT}	Output Voltage	$V_{IN} = 4V$ to $12V$ $I_{LOAD} = 500$ mA to $1.45A$	5.0	4.80/ 4.75	5.20/ 5.25	V
$\Delta V_{OUT}/\Delta V_{IN}$	Line Regulation	$V_{IN} = 4V$ to $12V$ $I_{LOAD} = 500$ mA	20		50/ 100	mV
$\Delta V_{OUT}/\Delta I_{LOAD}$	Load Regulation	$V_{IN} = 12V$ $I_{LOAD} = 500$ mA to $1.45A$	20		50/ 100	mV
η	Efficiency	$V_{IN} = 12V$, $I_{LOAD} = 750$ mA	80			%

Electrical Characteristics

Specifications with standard type face are for $T_J = 25^\circ\text{C}$, and those in **bold type face** apply over full **Operating Temperature Range**. Unless otherwise specified, $V_{IN} = 5\text{V}$. (Continued)

LM2587-5.0 (Continued)

Symbol	Parameters	Conditions	Typical	Min	Max	Units
UNIQUE DEVICE PARAMETERS (Note 5)						
V_{REF}	Output Reference Voltage	Measured at Feedback Pin $V_{COMP} = 1.0\text{V}$	5.0	4.913/ 4.900	5.088/ 5.100	V
ΔV_{REF}	Reference Voltage Line Regulation	$V_{IN} = 4\text{V to }40\text{V}$	3.3			mV
G_M	Error Amp Transconductance	$I_{COMP} = -30\ \mu\text{A to }+30\ \mu\text{A}$ $V_{COMP} = 1.0\text{V}$	0.750	0.447	1.491	mmho
A_{VOL}	Error Amp Voltage Gain	$V_{COMP} = 0.5\text{V to }1.6\text{V}$ $R_{COMP} = 1.0\ \text{M}\Omega$ (Note 6)	165	99/ 49		V/V

LM2587-12

Symbol	Parameters	Conditions	Typical	Min	Max	Units
SYSTEM PARAMETERS Test Circuit of <i>Figure 3</i> (Note 4)						
V_{OUT}	Output Voltage	$V_{IN} = 4\text{V to }10\text{V}$ $I_{LOAD} = 300\ \text{mA to }1.2\text{A}$	12.0	11.52/ 11.40	12.48/ 12.60	V
$\Delta V_{OUT}/\Delta V_{IN}$	Line Regulation	$V_{IN} = 4\text{V to }10\text{V}$ $I_{LOAD} = 300\ \text{mA}$	20		100/ 200	mV
$\Delta V_{OUT}/\Delta I_{LOAD}$	Load Regulation	$V_{IN} = 10\text{V}$ $I_{LOAD} = 300\ \text{mA to }1.2\text{A}$	20		100/ 200	mV
η	Efficiency	$V_{IN} = 10\text{V}, I_{LOAD} = 1\text{A}$	90			%

UNIQUE DEVICE PARAMETERS (Note 5)

V_{REF}	Output Reference Voltage	Measured at Feedback Pin $V_{COMP} = 1.0\text{V}$	12.0	11.79/ 11.76	12.21/ 12.24	V
ΔV_{REF}	Reference Voltage Line Regulation	$V_{IN} = 4\text{V to }40\text{V}$	7.8			mV
G_M	Error Amp Transconductance	$I_{COMP} = -30\ \mu\text{A to }+30\ \mu\text{A}$ $V_{COMP} = 1.0\text{V}$	0.328	0.186	0.621	mmho
A_{VOL}	Error Amp Voltage Gain	$V_{COMP} = 0.5\text{V to }1.6\text{V}$ $R_{COMP} = 1.0\ \text{M}\Omega$ (Note 6)	70	41/ 21		V/V

LM2587-ADJ

Symbol	Parameters	Conditions	Typical	Min	Max	Units
SYSTEM PARAMETERS Test Circuit of <i>Figure 3</i> (Note 4)						
V_{OUT}	Output Voltage	$V_{IN} = 4\text{V to }10\text{V}$ $I_{LOAD} = 300\ \text{mA to }1.2\text{A}$	12.0	11.52/ 11.40	12.48/ 12.60	V
$\Delta V_{OUT}/\Delta V_{IN}$	Line Regulation	$V_{IN} = 4\text{V to }10\text{V}$ $I_{LOAD} = 300\ \text{mA}$	20		100/ 200	mV
$\Delta V_{OUT}/\Delta I_{LOAD}$	Load Regulation	$V_{IN} = 10\text{V}$ $I_{LOAD} = 300\ \text{mA to }1.2\text{A}$	20		100/ 200	mV
η	Efficiency	$V_{IN} = 10\text{V}, I_{LOAD} = 1\text{A}$	90			%

Electrical Characteristics

Specifications with standard type face are for $T_J = 25^\circ\text{C}$, and those in **bold type face** apply over full **Operating Temperature Range**. Unless otherwise specified, $V_{IN} = 5\text{V}$. (Continued)

LM2587-ADJ (Continued)

Symbol	Parameters	Conditions	Typical	Min	Max	Units
UNIQUE DEVICE PARAMETERS (Note 5)						
V_{REF}	Output Reference Voltage	Measured at Feedback Pin $V_{COMP} = 1.0\text{V}$	1.230	1.208/ 1.205	1.252/ 1.255	V
ΔV_{REF}	Reference Voltage Line Regulation	$V_{IN} = 4\text{V to }40\text{V}$	1.5			mV
G_M	Error Amp Transconductance	$I_{COMP} = -30\ \mu\text{A to }+30\ \mu\text{A}$ $V_{COMP} = 1.0\text{V}$	3.200	1.800	6.000	mmho
A_{VOL}	Error Amp Voltage Gain	$V_{COMP} = 0.5\text{V to }1.6\text{V}$ $R_{COMP} = 1.0\ \text{M}\Omega$ (Note 6)	670	400/ 200		V/V
I_B	Error Amp Input Bias Current	$V_{COMP} = 1.0\text{V}$	125		425/ 600	nA
COMMON DEVICE PARAMETERS for all versions (Note 5)						
Symbol	Parameters	Conditions	Typical	Min	Max	Units
I_S	Input Supply Current	(Switch Off) (Note 8)	11		15.5/ 16.5	mA
		$I_{SWITCH} = 3.0\text{A}$	85	140	165	mA
V_{UV}	Input Supply Undervoltage Lockout	$R_{LOAD} = 100\Omega$	3.30	3.05	3.75	V
f_O	Oscillator Frequency	Measured at Switch Pin $R_{LOAD} = 100\Omega$ $V_{COMP} = 1.0\text{V}$	100	85/ 75	115/ 125	kHz
f_{SC}	Short-Circuit Frequency	Measured at Switch Pin $R_{LOAD} = 100\Omega$ $V_{FEEDBACK} = 1.15\text{V}$	25			kHz
V_{EAO}	Error Amplifier Output Swing	Upper Limit (Note 7)	2.8	2.6/ 2.4		V
		Lower Limit (Note 8)	0.25		0.40/ 0.55	V
I_{EAO}	Error Amp Output Current (Source or Sink)	(Note 9)	165	110/ 70	260/ 320	μA
I_{SS}	Soft Start Current	$V_{FEEDBACK} = 0.92\text{V}$ $V_{COMP} = 1.0\text{V}$	11.0	8.0/ 7.0	17.0/ 19.0	μA
D	Maximum Duty Cycle	$R_{LOAD} = 100\Omega$ (Note 7)	98	93/ 90		%
I_L	Switch Leakage Current	Switch Off $V_{SWITCH} = 60\text{V}$	15		300/ 600	μA
V_{SUS}	Switch Sustaining Voltage	$dV/dT = 1.5\text{V/ns}$		65		V
V_{SAT}	Switch Saturation Voltage	$I_{SWITCH} = 5.0\text{A}$	0.7		1.1/ 1.4	V
I_{CL}	NPN Switch Current Limit		6.5	5.0	9.5	A

Electrical Characteristics

Specifications with standard type face are for $T_J = 25^\circ\text{C}$, and those in **bold type face** apply over full **Operating Temperature Range**. Unless otherwise specified, $V_{IN} = 5\text{V}$. (Continued)

COMMON DEVICE PARAMETERS (Note 4) (Continued)

Symbol	Parameters	Conditions	Typical	Min	Max	Units
θ_{JA}	Thermal Resistance	T Package, Junction to Ambient (Note 10)	65			$^\circ\text{C}/\text{W}$
θ_{JA}		T Package, Junction to Ambient (Note 11)	45			
θ_{JC}		T Package, Junction to Case	2			
θ_{JA}		S Package, Junction to Ambient (Note 12)	56			
θ_{JA}		S Package, Junction to Ambient (Note 13)	35			
θ_{JA}		S Package, Junction to Ambient (Note 14)	26			
θ_{JC}		S Package, Junction to Case	2			

Note 1: Absolute Maximum Ratings indicate limits beyond which damage to the device may occur. Operating ratings indicate conditions the device is intended to be functional, but device parameter specifications may not be guaranteed under these conditions. For guaranteed specifications and test conditions, see the Electrical Characteristics.

Note 2: Note that switch current and output current are not identical in a step-up regulator. Output current cannot be internally limited when the LM2587 is used as a step-up regulator. To prevent damage to the switch, the output current must be externally limited to 5A. However, output current is internally limited when the LM2587 is used as a flyback regulator (see the Application Hints section for more information).

Note 3: The junction temperature of the device (T_J) is a function of the ambient temperature (T_A), the junction-to-ambient thermal resistance (θ_{JA}), and the power dissipation of the device (P_D). A thermal shutdown will occur if the temperature exceeds the maximum junction temperature of the device: $P_D \times \theta_{JA} + T_{A(\text{MAX})} \geq T_{J(\text{MAX})}$. For a safe thermal design, check that the maximum power dissipated by the device is less than: $P_D \leq [T_{J(\text{MAX})} - T_{A(\text{MAX})}] / \theta_{JA}$. When calculating the maximum allowable power dissipation, derate the maximum junction temperature—this ensures a margin of safety in the thermal design.

Note 4: External components such as the diode, inductor, input and output capacitors can affect switching regulator performance. When the LM2587 is used as shown in *Figures 2* and *3*, system performance will be as specified by the system parameters.

Note 5: All room temperature limits are 100% production tested, and all limits at temperature extremes are guaranteed via correlation using standard Statistical Quality Control (SQC) methods.

Note 6: A 1.0 M Ω resistor is connected to the compensation pin (which is the error amplifier output) to ensure accuracy in measuring A_{VOL} .

Note 7: To measure this parameter, the feedback voltage is set to a low value, depending on the output version of the device, to force the error amplifier output high. Adj: $V_{FB} = 1.05\text{V}$; 3.3V: $V_{FB} = 2.81\text{V}$; 5.0V: $V_{FB} = 4.25\text{V}$; 12V: $V_{FB} = 10.20\text{V}$.

Note 8: To measure this parameter, the feedback voltage is set to a high value, depending on the output version of the device, to force the error amplifier output low. Adj: $V_{FB} = 1.41\text{V}$; 3.3V: $V_{FB} = 3.80\text{V}$; 5.0V: $V_{FB} = 5.75\text{V}$; 12V: $V_{FB} = 13.80\text{V}$.

Note 9: To measure the worst-case error amplifier output current, the LM2587 is tested with the feedback voltage set to its low value (specified in Note 7) and at its high value (specified in Note 8).

Note 10: Junction to ambient thermal resistance (no external heat sink) for the 5 lead TO-220 package mounted vertically, with $\frac{1}{2}$ inch leads in a socket, or on a PC board with minimum copper area.

Note 11: Junction to ambient thermal resistance (no external heat sink) for the 5 lead TO-220 package mounted vertically, with $\frac{1}{2}$ inch leads soldered to a PC board containing approximately 4 square inches of (1oz.) copper area surrounding the leads.

Note 12: Junction to ambient thermal resistance for the 5 lead TO-263 mounted horizontally against a PC board area of 0.136 square inches (the same size as the TO-263 package) of 1 oz. (0.0014 in. thick) copper.

Note 13: Junction to ambient thermal resistance for the 5 lead TO-263 mounted horizontally against a PC board area of 0.4896 square inches (3.6 times the area of the TO-263 package) of 1 oz. (0.0014 in. thick) copper.

Note 14: Junction to ambient thermal resistance for the 5 lead TO-263 mounted horizontally against a PC board copper area of 1.0064 square inches (7.4 times the area of the TO-263 package) of 1 oz. (0.0014 in. thick) copper. Additional copper area will reduce thermal resistance further. See the thermal model in **Switchers Made Simple**[®] software.

Typical Performance Characteristics

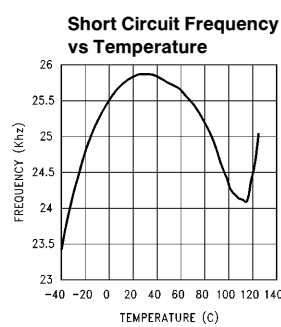
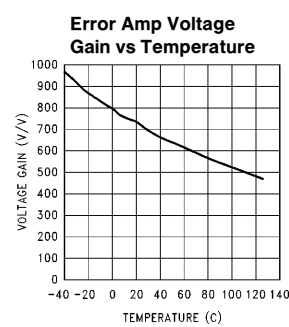
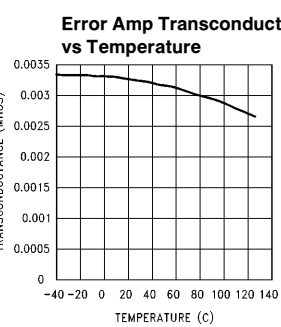
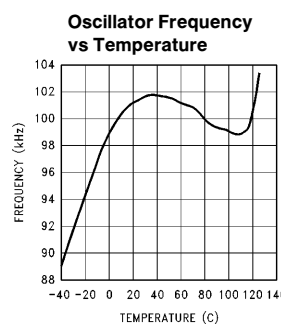
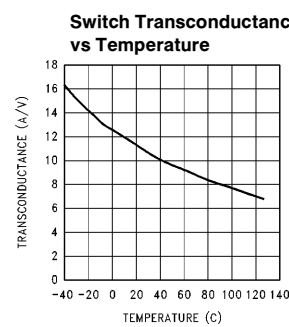
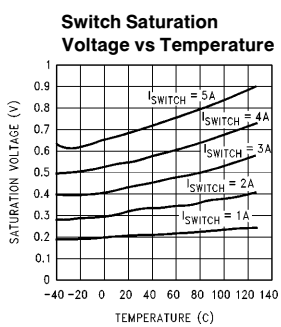
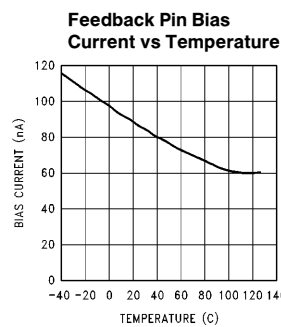
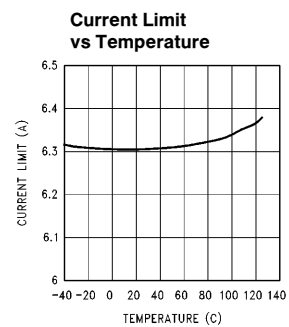
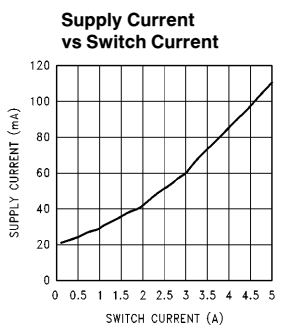
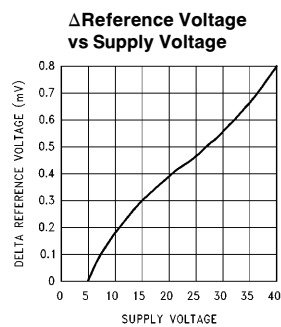
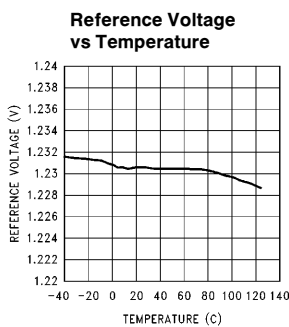
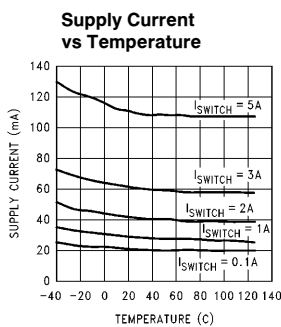

TL/H/12316-2

Connection Diagrams

**Bent, Staggered Leads
5-Lead TO-220 (T)**

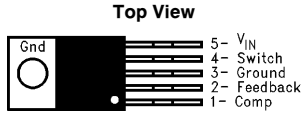

TL/H/12316-3

**Order Number LM2587T-3.3, LM2587T-5.0,
LM2587T-12 or LM2587T-ADJ**
See NS Package Number T05D

**Bent, Staggered Leads
5-Lead TO-220 (T)**

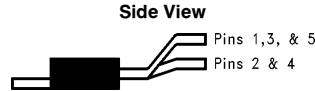

TL/H/12316-4

5-Lead TO-263 (S)

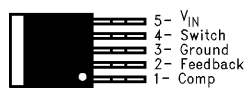

TL/H/12316-5

**Order Number LM2587S-3.3, LM2587S-5.0,
LM2587S-12 or LM2587S-ADJ**
See NS Package Number TS5B

5-Lead TO-263 (S)



TL/H/12316-6

Block Diagram

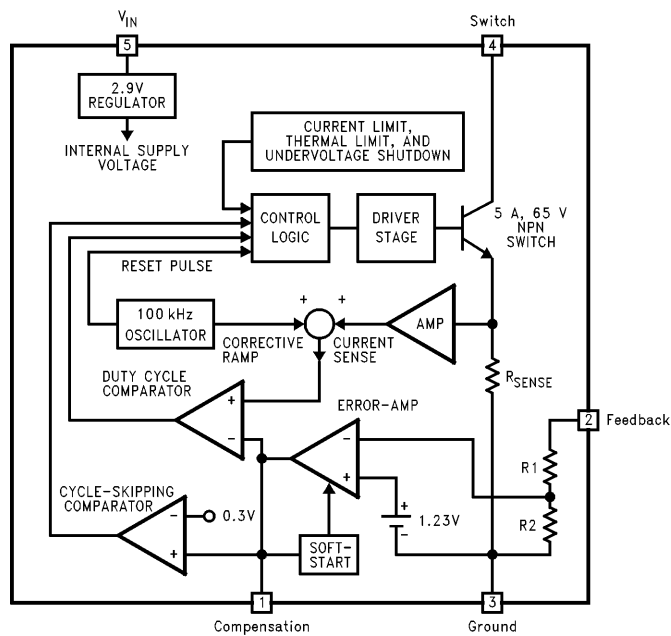

For Fixed Versions
3.3V, $R1 = 3.4k$, $R2 = 2k$
5V, $R1 = 6.15k$, $R2 = 2k$
12V, $R1 = 8.73k$, $R2 = 1k$
For Adj. Version
 $R1 = \text{Short } (0\Omega)$, $R2 = \text{Open}$

TL/H/12316-7

FIGURE 1

Test Circuits

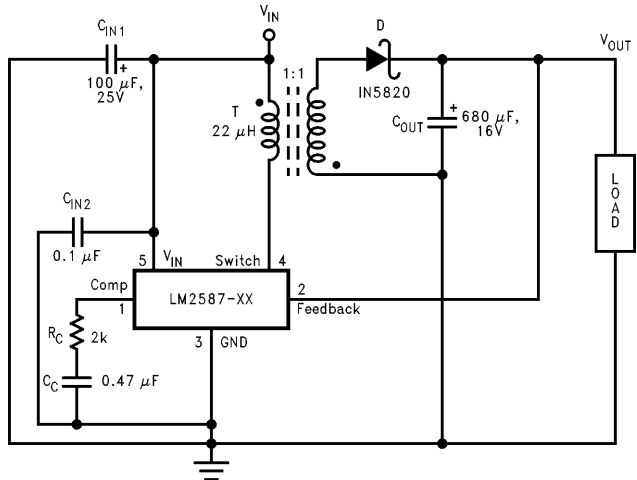

C_{IN1} —100 μ F, 25V Aluminum Electrolytic
 C_{IN2} —0.1 μ F Ceramic
 T —22 μ H, 1:1 Schott #67141450
 D —1N5820
 C_{OUT} —680 μ F, 16V Aluminum Electrolytic
 C_C —0.47 μ F Ceramic
 R_C —2k

TL/H/12316-8

FIGURE 2. LM2587-3.3 and LM2587-5.0

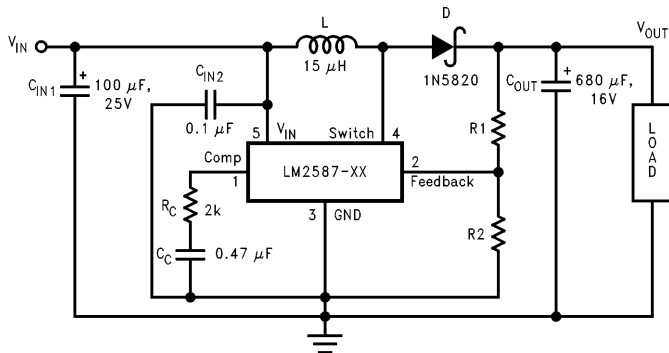

C_{IN1} —100 μ F, 25V Aluminum Electrolytic
 C_{IN2} —0.1 μ F Ceramic
 L —15 μ H, Renco #RL-5472-5
 D —1N5820
 C_{OUT} —680 μ F, 16V Aluminum Electrolytic
 C_C —0.47 μ F Ceramic
 R_C —2k
 For 12V Devices: R_1 = Short (0 Ω) and R_2 = Open
 For ADJ Devices: R_1 = 48.75k, \pm 0.1% and R_2 = 5.62k, \pm 1%

TL/H/12316-9

FIGURE 3. LM2587-12 and LM2587-ADJ

Flyback Regulator Operation

The LM2587 is ideally suited for use in the flyback regulator topology. The flyback regulator can produce a single output voltage, such as the one shown in *Figure 4*, or multiple output voltages. In *Figure 4*, the flyback regulator generates an output voltage that is inside the range of the input voltage. This feature is unique to flyback regulators and cannot be duplicated with buck or boost regulators.

The operation of a flyback regulator is as follows (refer to *Figure 4*): when the switch is on, current flows through the primary winding of the transformer, T1, storing energy in the magnetic field of the transformer. Note that the primary and secondary windings are out of phase, so no current flows through the secondary when current flows through the primary. When the switch turns off, the magnetic field col-

lapses, reversing the voltage polarity of the primary and secondary windings. Now rectifier D1 is forward biased and current flows through it, releasing the energy stored in the transformer. This produces voltage at the output.

The output voltage is controlled by modulating the peak switch current. This is done by feeding back a portion of the output voltage to the error amp, which amplifies the difference between the feedback voltage and a 1.230V reference. The error amp output voltage is compared to a ramp voltage proportional to the switch current (i.e., inductor current during the switch on time). The comparator terminates the switch on time when the two voltages are equal, thereby controlling the peak switch current to maintain a constant output voltage.

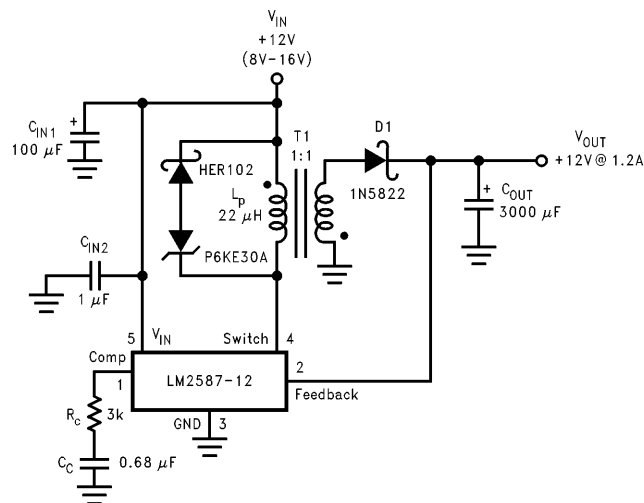

TL/H/12316-10

As shown in *Figure 4*, the LM2587 can be used as a flyback regulator by using a minimum number of external components. The switching waveforms of this regulator are shown in *Figure 5*. Typical Performance Characteristics observed during the operation of this circuit are shown in *Figure 6*.

FIGURE 4. 12V Flyback Regulator Design Example

Typical Performance Characteristics

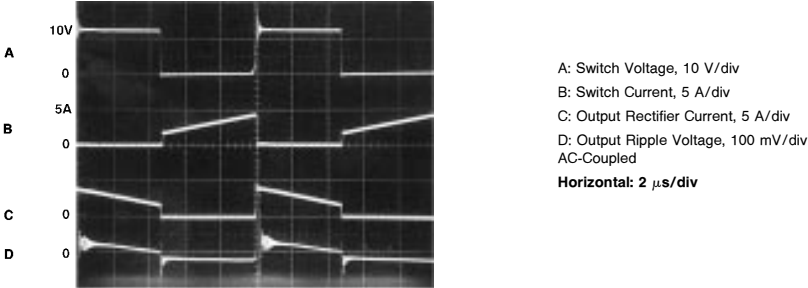

TL/H/12316-11
FIGURE 5. Switching Waveforms

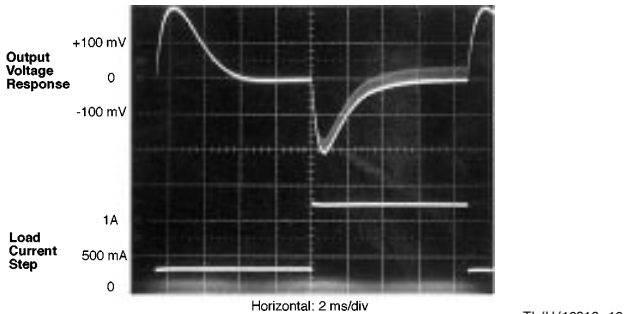

TL/H/12316-12
FIGURE 6. V_{OUT} Load Current Step Response

Typical Flyback Regulator Applications

Figures 7 through 12 show six typical flyback applications, varying from single output to triple output. Each drawing contains the part number(s) and manufacturer(s) for every component except the transformer. For the transformer part numbers and manufacturers names, see the table in

Figure 13. For applications with different output voltages—requiring the LM2587-ADJ—or different output configurations that do not match the standard configurations, refer to the *Switchers Made Simple*® software.

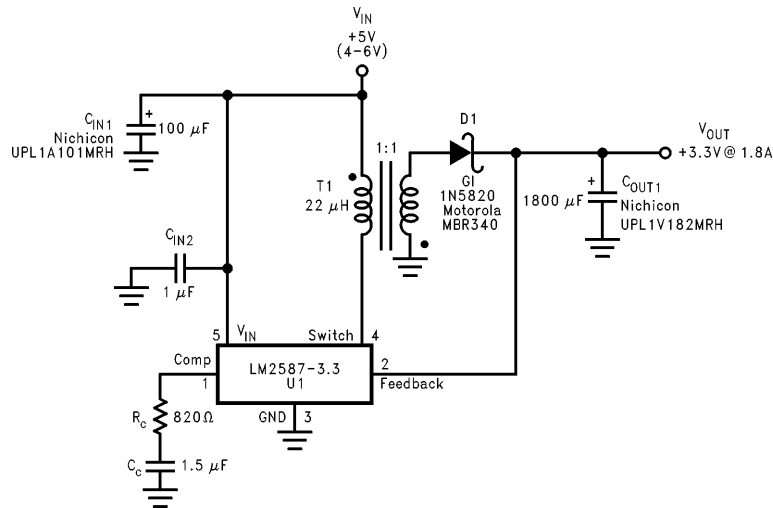

FIGURE 7. Single-Output Flyback Regulator

TL/H/12316-13

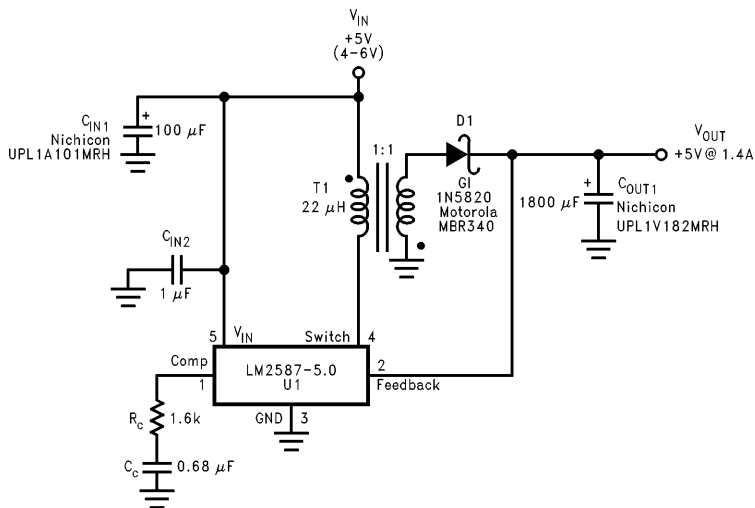

FIGURE 8. Single-Output Flyback Regulator

TL/H/12316-14

Typical Flyback Regulator Applications (Continued)

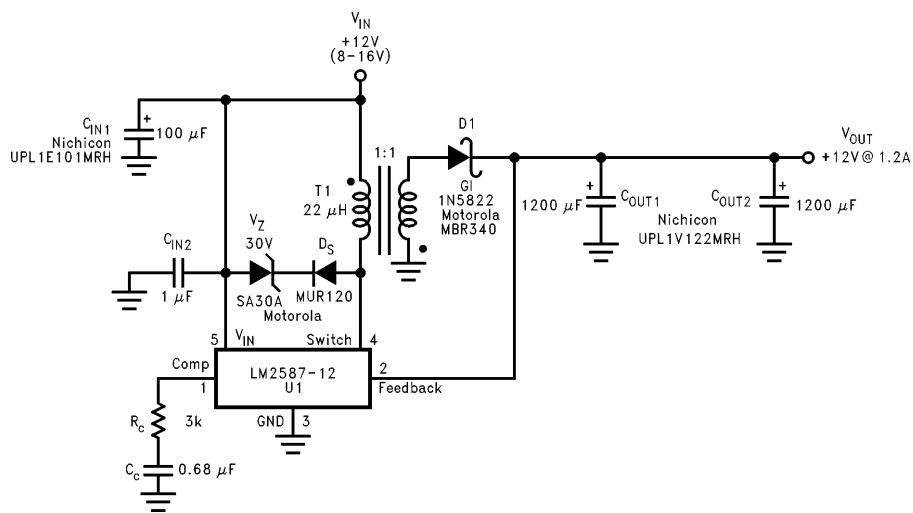

FIGURE 9. Single-Output Flyback Regulator

TL/H/12316-15

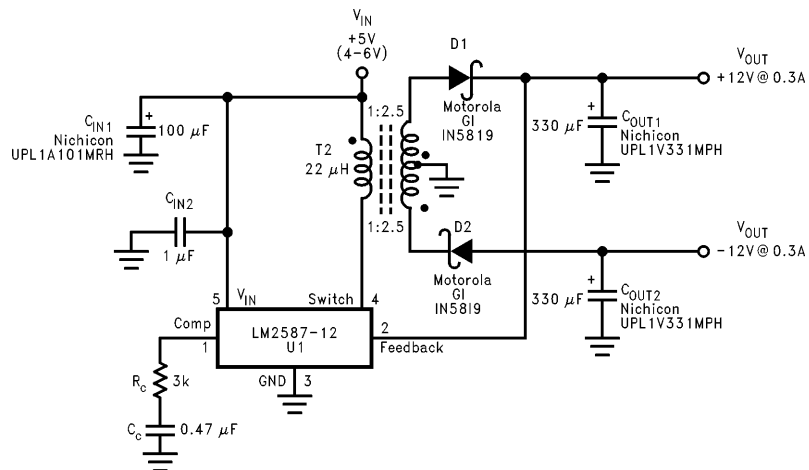

FIGURE 10. Dual-Output Flyback Regulator

TL/H/12316-16

Typical Flyback Regulator Applications (Continued)

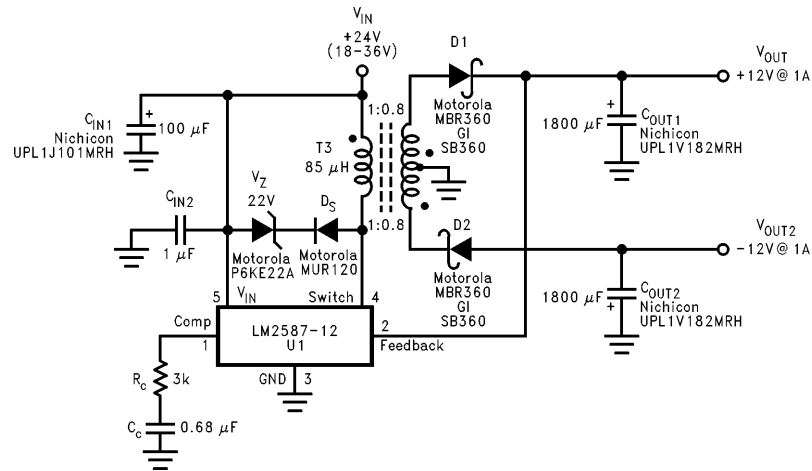

FIGURE 11. Dual-Output Flyback Regulator

TL/H/12316-17

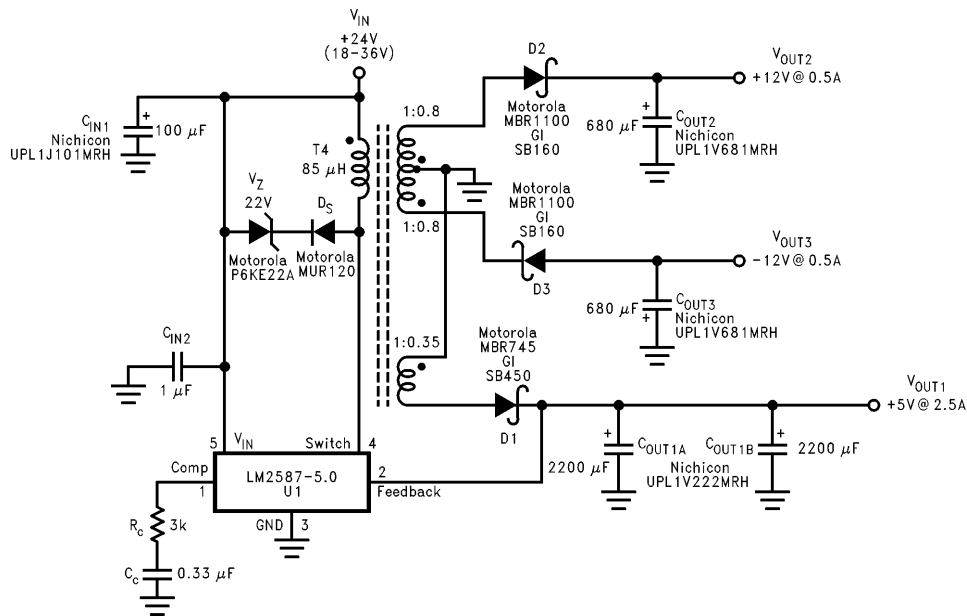

FIGURE 12. Triple-Output Flyback Regulator

TL/H/12316-18

Typical Flyback Regulator Applications (Continued)

Transformer Selection (T)

Figure 13 lists the standard transformers available for flyback regulator applications. Included in the table are the turns ratio(s) for each transformer, as well as the output voltages, input voltage ranges, and the maximum load currents for each circuit.

Applications	Figure 7	Figure 8	Figure 9	Figure 10	Figure 11	Figure 12
Transformers	T1	T1	T1	T2	T3	T4
V_{IN}	4V–6V	4V–6V	8V–16V	4V–6V	18V–36V	18V–36V
V_{OUT1}	3.3V	5V	12V	12V	12V	5V
I_{OUT1} (Max)	1.8A	1.4A	1.2A	0.3A	1A	2.5A
N_1	1	1	1	2.5	0.8	0.35
V_{OUT2}				–12V	–12V	12V
I_{OUT2} (Max)				0.3A	1A	0.5A
N_2				2.5	0.8	0.8
V_{OUT3}						–12V
I_{OUT3} (Max)						0.5A
N_3						0.8

FIGURE 13. Transformer Selection Table

Transformer Type	Manufacturers' Part Numbers				
	Coilcraft ¹	Coilcraft ¹ Surface Mount	Pulse ² Surface Mount	Renco ³	Schott ⁴
T1	Q4434-B	Q4435-B	PE-68411	RL-5530	67141450
T2	Q4337-B	Q4436-B	PE-68412	RL-5531	67140860
T3	Q4343-B	—	PE-68421	RL-5534	67140920
T4	Q4344-B	—	PE-68422	RL-5535	67140930

Note 1: Coilcraft Inc.,
1102 Silver Lake Road, Cary, IL 60013

Phone: (800) 322-2645
Fax: (708) 639-1469

Note 2: Pulse Engineering Inc.,
12220 World Trade Drive, San Diego, CA 92128

Phone: (619) 674-8100
Fax: (619) 674-8262

Note 3: Renco Electronics Inc.,
60 Jeffryn Blvd. East, Deer Park, NY 11729

Phone: (800) 645-5828
Fax: (516) 586-5562

Note 4: Schott Corp.,
1000 Parkers Lane Road, Wayzata, MN 55391

Phone: (612) 475-1173
Fax: (612) 475-1786

FIGURE 14. Transformer Manufacturer Guide

Typical Flyback Regulator Applications (Continued)

Transformer Footprints

Figures 15 through 32 show the footprints of each transformer, listed in Figure 14.

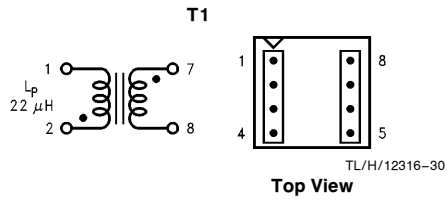

FIGURE 15. Coilcraft Q4434-B

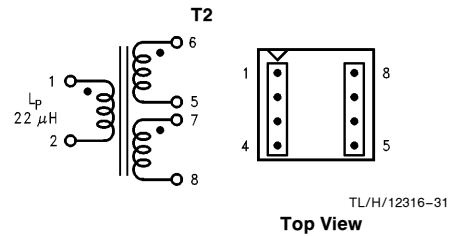

FIGURE 16. Coilcraft Q4337-B

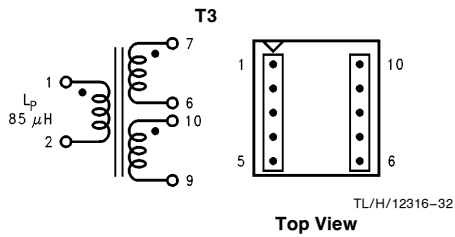

FIGURE 17. Coilcraft Q4343-B

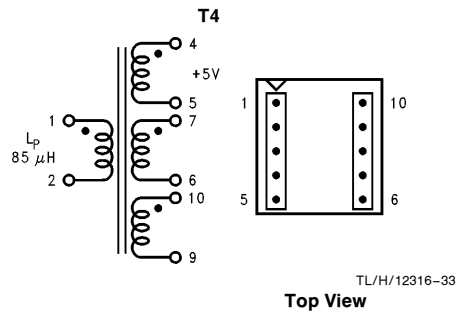
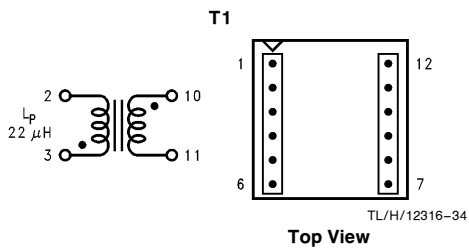
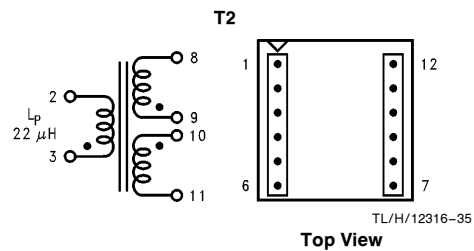

FIGURE 18. Coilcraft Q4344-B

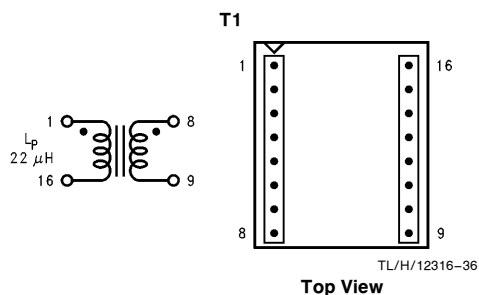

**FIGURE 19. Coilcraft Q4435-B
(Surface Mount)**

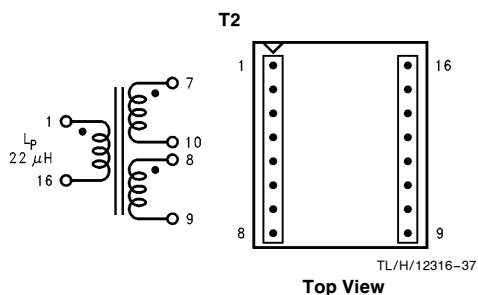

**FIGURE 20. Coilcraft Q4436-B
(Surface Mount)**

Typical Flyback Regulator Applications (Continued)



**FIGURE 21. Pulse PE-68411
(Surface Mount)**



**FIGURE 22. Pulse PE-68412
(Surface Mount)**

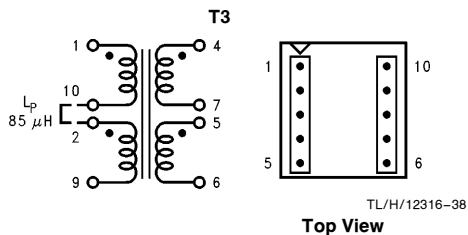

**FIGURE 23. Pulse PE-68421
(Surface Mount)**

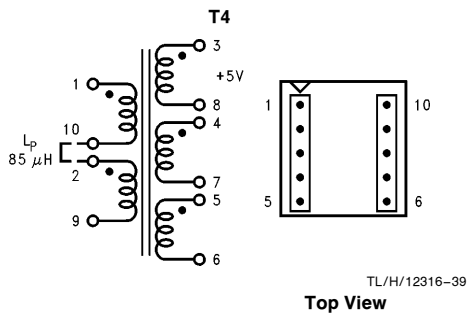

**FIGURE 24. Pulse PE-68422
(Surface Mount)**

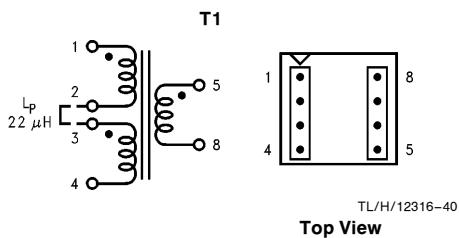

FIGURE 25. Renco RL-5530

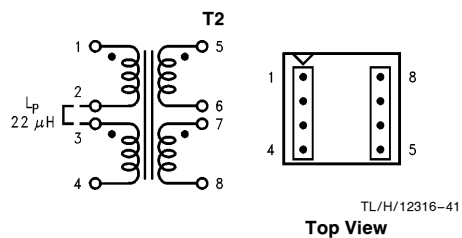

FIGURE 26. Renco RL-5531

Typical Flyback Regulator Applications (Continued)

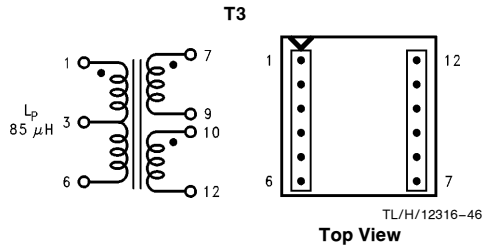

FIGURE 27. Renco RL-5534

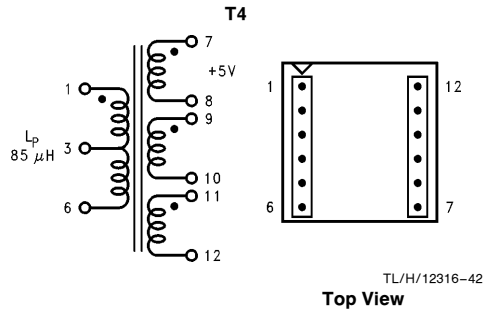

FIGURE 28. Renco RL-5535

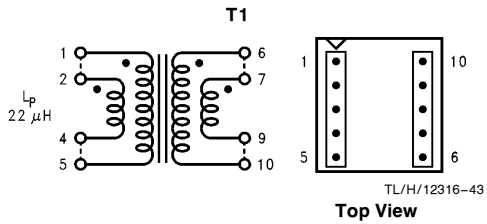

FIGURE 29. Schott 67141450

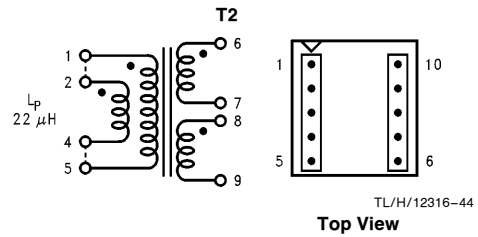

FIGURE 30. Schott 67140860

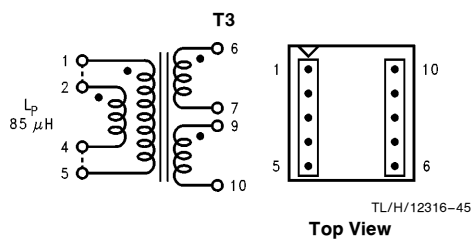

FIGURE 31. Schott 67140920

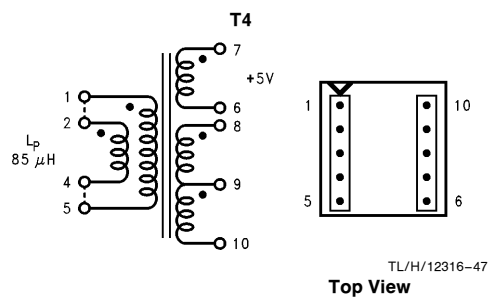

FIGURE 32. Schott 67140930

Step-Up (Boost) Regulator Operation

Figure 33 shows the LM2587 used as a step-up (boost) regulator. This is a switching regulator that produces an output voltage greater than the input supply voltage.

A brief explanation of how the LM2587 Boost Regulator works is as follows (refer to Figure 33). When the NPN switch turns on, the inductor current ramps up at the rate of V_{IN}/L , storing energy in the inductor. When the switch turns

off, the lower end of the inductor flies above V_{IN} , discharging its current through diode (D) into the output capacitor (C_{OUT}) at a rate of $(V_{OUT} - V_{IN})/L$. Thus, energy stored in the inductor during the switch on time is transferred to the output during the switch off time. The output voltage is controlled by adjusting the peak switch current, as described in the flyback regulator section.

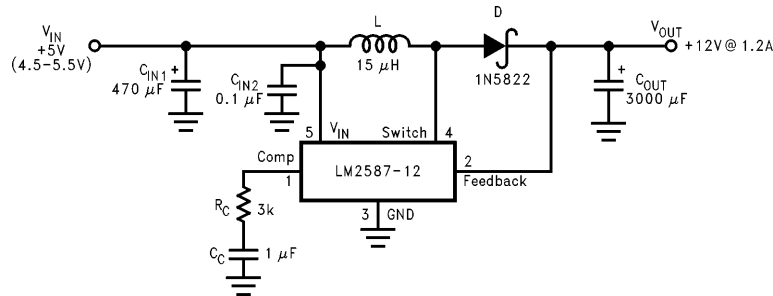

TL/H/12316-19

By adding a small number of external components (as shown in Figure 33), the LM2587 can be used to produce a regulated output voltage that is greater than the applied input voltage. The switching waveforms observed during the operation of this circuit are shown in Figure 34. Typical performance of this regulator is shown in Figure 35.

FIGURE 33. 12V Boost Regulator

Typical Performance Characteristics

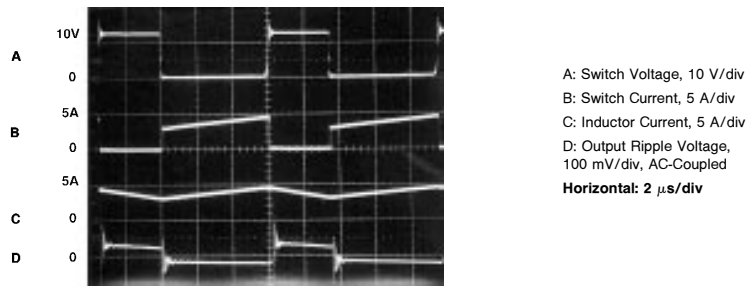

TL/H/12316-20

FIGURE 34. Switching Waveforms

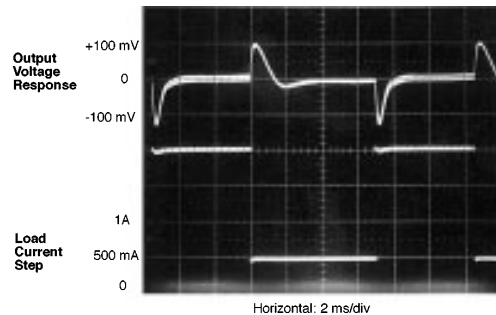

TL/H/12316-21

FIGURE 35. V_{OUT} Response to Load Current Step

Typical Boost Regulator Applications

Figures 36 and 38 through 40 show four typical boost applications—one fixed and three using the adjustable version of the LM2587. Each drawing contains the part number(s) and manufacturer(s) for every component. For the fixed 12V

output application, the part numbers and manufacturers' names for the inductor are listed in a table in Figure 40. For applications with different output voltages, refer to the *Switchers Made Simple*® software.

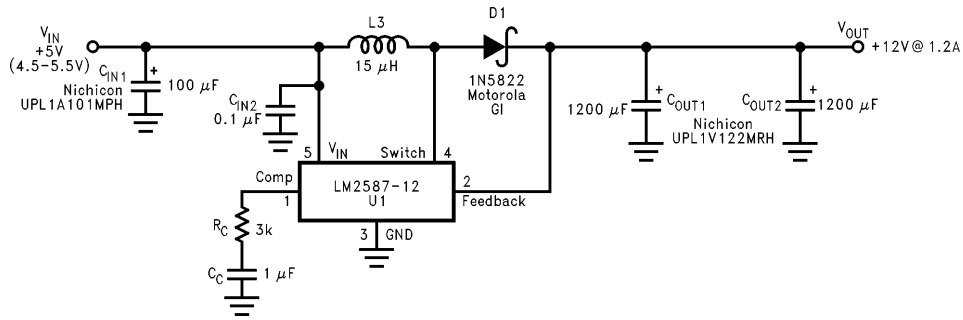

FIGURE 36. +5V to +12V Boost Regulator

TL/H/12316-22

Figure 37 contains a table of standard inductors, by part number and corresponding manufacturer, for the fixed output regulator of Figure 36.

Coilcraft ¹	Pulse ²	Renco ³	Schott ⁴
R4793-A	PE-53900	RL-5472-5	67146520

Note 1: Coilcraft Inc.,
1102 Silver Lake Road, Cary, IL 60013

Phone: (800) 322-2645
Fax: (708) 639-1469

Note 2: Pulse Engineering Inc.,
12220 World Trade Drive, San Diego, CA 92128

Phone: (619) 674-8100
Fax: (619) 674-8262

Note 3: Renco Electronics Inc.,
60 Jeffrym Blvd. East, Deer Park, NY 11729

Phone: (800) 645-5828
Fax: (516) 586-5562

Note 4: Schott Corp.,
1000 Parkers Lane Road, Wayzata, MN 55391

Phone: (612) 475-1173
Fax: (612) 475-1786

FIGURE 37. Inductor Selection Table

Typical Boost Regulator Applications (Continued)

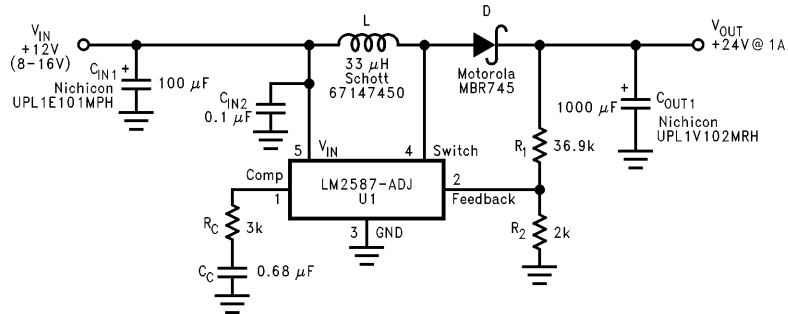

FIGURE 38. +12V to +24V Boost Regulator

TL/H/12316-23

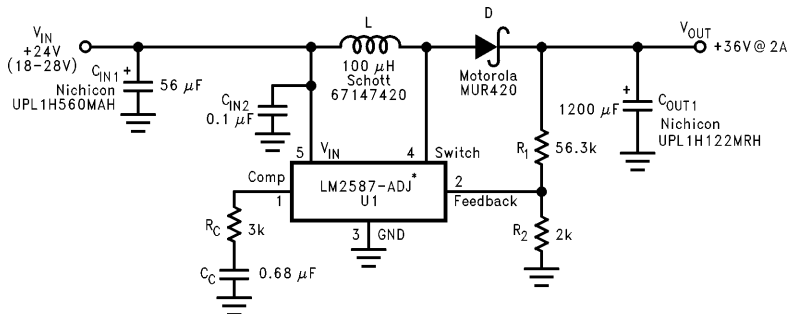

FIGURE 39. +24V to +36V Boost Regulator

TL/H/12316-24

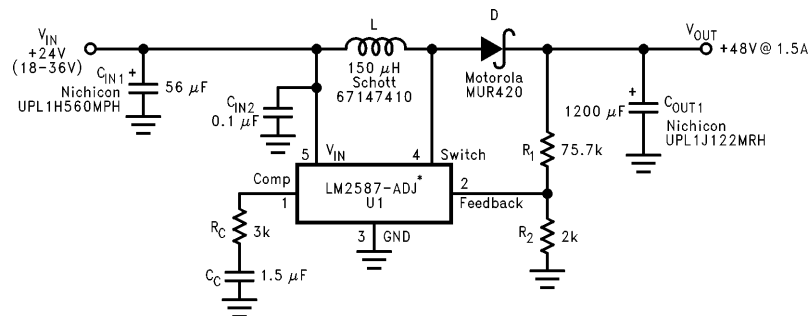

FIGURE 40. +24V to +48V Boost Regulator

TL/H/12316-25

*The LM2587 will require a heat sink in these applications. The size of the heat sink will depend on the maximum ambient temperature. To calculate the thermal resistance of the IC and the size of the heat sink needed, see the "Heat Sink/Thermal Considerations" section in the Application Hints.

Application Hints

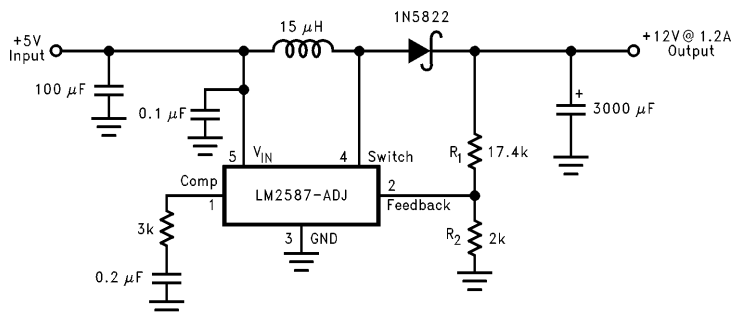

FIGURE 41. Boost Regulator

TL/H/12316-26

PROGRAMMING OUTPUT VOLTAGE (SELECTING R_1 AND R_2)

Referring to the adjustable regulator in *Figure 41*, the output voltage is programmed by the resistors R_1 and R_2 by the following formula:

$$V_{OUT} = V_{REF} (1 + R_1/R_2) \quad \text{where } V_{REF} = 1.23V$$

Resistors R_1 and R_2 divide the output voltage down so that it can be compared with the 1.23V internal reference. With R_2 between 1k and 5k, R_1 is:

$$R_1 = R_2 (V_{OUT}/V_{REF} - 1) \quad \text{where } V_{REF} = 1.23V$$

For best temperature coefficient and stability with time, use 1% metal film resistors.

SHORT CIRCUIT CONDITION

Due to the inherent nature of boost regulators, when the output is shorted (see *Figure 41*), current flows directly from the input, through the inductor and the diode, to the output, bypassing the switch. The current limit of the switch *does not* limit the output current for the entire circuit. To protect the load and prevent damage to the switch, the current must be externally limited, either by the input supply or at the out-

put with an external current limit circuit. The external limit should be set to the maximum switch current of the device, which is 5A.

In a flyback regulator application (*Figure 42*), using the standard transformers, the LM2587 will survive a short circuit to the main output. When the output voltage drops to 80% of its nominal value, the frequency will drop to 25 kHz. With a lower frequency, off times are larger. With the longer off times, the transformer can release all of its stored energy before the switch turns back on. Hence, the switch turns on initially with zero current at its collector. In this condition, the switch current limit will limit the peak current, saving the device.

FLYBACK REGULATOR INPUT CAPACITORS

A flyback regulator draws discontinuous pulses of current from the input supply. Therefore, there are two input capacitors needed in a flyback regulator; one for energy storage and one for filtering (see *Figure 42*). Both are required due to the inherent operation of a flyback regulator. To keep a stable or constant voltage supply to the LM2587, a stor-

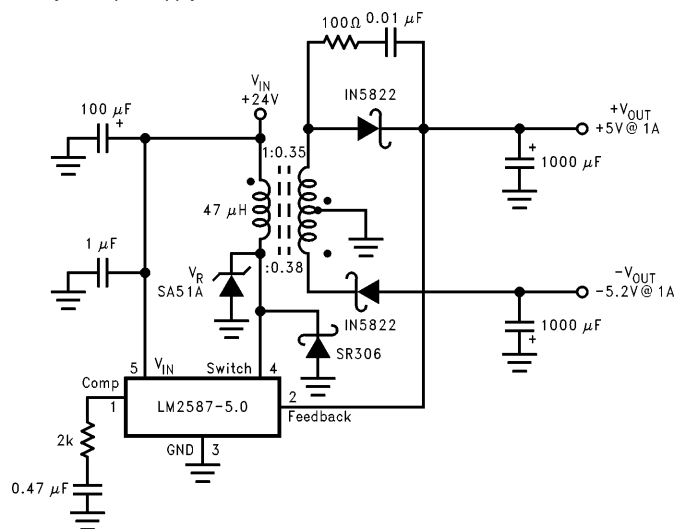

FIGURE 42. Flyback Regulator

TL/H/12316-27

Application Hints (Continued)

age capacitor ($\geq 100 \mu\text{F}$) is required. If the input source is a rectified DC supply and/or the application has a wide temperature range, the required rms current rating of the capacitor might be very large. This means a larger value of capacitance or a higher voltage rating will be needed of the input capacitor. The storage capacitor will also attenuate noise which may interfere with other circuits connected to the same input supply voltage.

In addition, a small bypass capacitor is required due to the noise generated by the input current pulses. To eliminate the noise, insert a $1.0 \mu\text{F}$ ceramic capacitor between V_{IN} and ground as close as possible to the device.

SWITCH VOLTAGE LIMITS

In a flyback regulator, the maximum steady-state voltage appearing at the switch, when it is off, is set by the transformer turns ratio, N , the output voltage, V_{OUT} , and the maximum input voltage, $V_{\text{IN}}(\text{Max})$:

$$V_{\text{SW(OFF)}} = V_{\text{IN}}(\text{Max}) + (V_{\text{OUT}} + V_{\text{F}})/N$$

where V_{F} is the forward biased voltage of the output diode, and is 0.5V for Schottky diodes and 0.8V for ultra-fast recovery diodes (typically). In certain circuits, there exists a voltage spike, V_{LL} , superimposed on top of the steady-state voltage (see *Figure 5*, waveform A). Usually, this voltage spike is caused by the transformer leakage inductance and/or the output rectifier recovery time. To “clamp” the voltage at the switch from exceeding its maximum value, a transient suppressor in series with a diode is inserted across the transformer primary (as shown in the circuit on the front page and other flyback regulator circuits throughout the datasheet). The schematic in *Figure 42* shows another method of clamping the switch voltage. A single voltage transient suppressor (the SA51A) is inserted at the switch pin. This method clamps the total voltage across the switch, not just the voltage across the primary.

If poor circuit layout techniques are used (see the “Circuit Layout Guideline” section), negative voltage transients may appear on the Switch pin (pin 4). Applying a negative voltage (with respect to the IC’s ground) to any monolithic IC pin causes erratic and unpredictable operation of that IC. This holds true for the LM2587 IC as well. When used in a flyback regulator, the voltage at the Switch pin (pin 4) can go negative when the switch turns on. The “ringing” voltage at the switch pin is caused by the output diode capacitance and the transformer leakage inductance forming a resonant circuit at the secondary(ies). The resonant circuit generates the “ringing” voltage, which gets reflected back through the transformer to the switch pin. There are two common methods to avoid this problem. One is to add an RC snubber around the output rectifier(s), as in *Figure 42*. The values of the resistor and the capacitor must be chosen so that the voltage at the Switch pin does not drop below -0.4V . The resistor may range in value between 10Ω and $1\text{k}\Omega$, and the capacitor will vary from $0.001 \mu\text{F}$ to $0.1 \mu\text{F}$. Adding a snubber will (slightly) reduce the efficiency of the overall circuit.

The other method to reduce or eliminate the “ringing” is to insert a Schottky diode clamp between pins 4 and 3 (ground), also shown in *Figure 42*. This prevents the voltage at pin 4 from dropping below -0.4V . The reverse voltage rating of the diode must be greater than the switch off voltage.

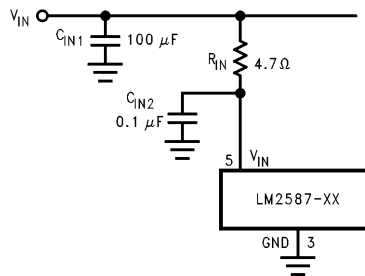

TL/H/12316-28

FIGURE 43. Input Line Filter

OUTPUT VOLTAGE LIMITATIONS

The maximum output voltage of a boost regulator is the maximum switch voltage minus a diode drop. In a flyback regulator, the maximum output voltage is determined by the turns ratio, N , and the duty cycle, D , by the equation:

$$V_{\text{OUT}} \approx N \times V_{\text{IN}} \times D / (1 - D)$$

The duty cycle of a flyback regulator is determined by the following equation:

$$D = \frac{V_{\text{OUT}} + V_{\text{F}}}{N(V_{\text{IN}} - V_{\text{SAT}}) + V_{\text{OUT}} + V_{\text{F}}} \approx \frac{V_{\text{OUT}}}{N(V_{\text{IN}}) + V_{\text{OUT}}}$$

Theoretically, the maximum output voltage can be as large as desired—just keep increasing the turns ratio of the transformer. However, there exists some physical limitations that prevent the turns ratio, and thus the output voltage, from increasing to infinity. The physical limitations are capacitances and inductances in the LM2587 switch, the output diode(s), and the transformer—such as reverse recovery time of the output diode (mentioned above).

NOISY INPUT LINE CONDITION

A small, low-pass RC filter should be used at the input pin of the LM2587 if the input voltage has an unusual large amount of transient noise, such as with an input switch that bounces. The circuit in *Figure 43* demonstrates the layout of the filter, with the capacitor placed from the input pin to ground and the resistor placed between the input supply and the input pin. Note that the values of R_{IN} and C_{IN} shown in the schematic are good enough for most applications, but some readjusting might be required for a particular application. If efficiency is a major concern, replace the resistor with a small inductor (say $10 \mu\text{H}$ and rated at 100mA).

STABILITY

All current-mode controlled regulators can suffer from an instability, known as subharmonic oscillation, if they operate with a duty cycle above 50%. To eliminate subharmonic oscillations, a minimum value of inductance is required to ensure stability for all boost and flyback regulators. The minimum inductance is given by:

$$L(\text{Min}) = \frac{2.92 [(V_{\text{IN}}(\text{Min}) - V_{\text{SAT}}) \times (2D(\text{Max}) - 1)]}{1 - D(\text{Max})} (\mu\text{H})$$

where V_{SAT} is the switch saturation voltage and can be found in the Characteristic Curves.

Application Hints (Continued)

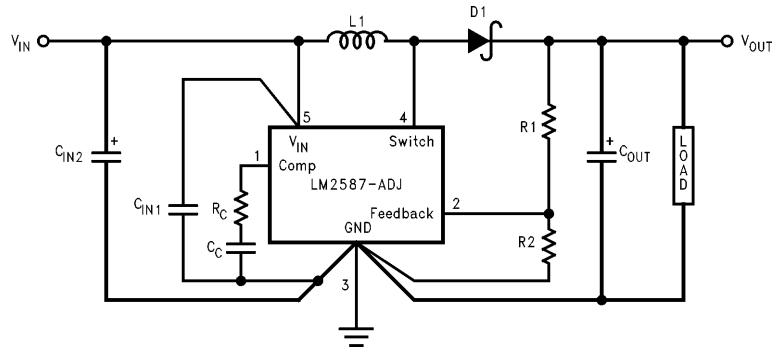

FIGURE 44. Circuit Board Layout

TL/H/12316-29

CIRCUIT LAYOUT GUIDELINES

As in any switching regulator, layout is very important. Rapidly switching currents associated with wiring inductance generate voltage transients which can cause problems. For minimal inductance and ground loops, keep the length of the leads and traces as short as possible. Use single point grounding or ground plane construction for best results. Separate the signal grounds from the power grounds (as indicated in Figure 44). When using the Adjustable version, physically locate the programming resistors as near the regulator IC as possible, to keep the sensitive feedback wiring short.

HEAT SINK/THERMAL CONSIDERATIONS

In many cases, no heat sink is required to keep the LM2587 junction temperature within the allowed operating range. For each application, to determine whether or not a heat sink will be required, the following must be identified:

- 1) Maximum ambient temperature (in the application).
- 2) Maximum regulator power dissipation (in the application).
- 3) Maximum allowed junction temperature (125°C for the LM2587). For a safe, conservative design, a temperature approximately 15°C cooler than the maximum junction temperature should be selected (110°C).
- 4) LM2587 package thermal resistances θ_{JA} and θ_{JC} (given in the Electrical Characteristics).

Total power dissipated (P_D) by the LM2587 can be estimated as follows:

Boost:

$$P_D = 0.15\Omega \times \left(\frac{I_{LOAD}}{1-D} \right)^2 \times D + \frac{I_{LOAD}}{50 \times (1-D)} \times D \times V_{IN}$$

Flyback:

$$P_D = 0.15\Omega \times \left(\frac{N \times \Sigma I_{LOAD}}{1-D} \right)^2 \times D + \frac{N \times \Sigma I_{LOAD}}{50 \times (1-D)} \times D \times V_{IN}$$

V_{IN} is the minimum input voltage, V_{OUT} is the output voltage, N is the transformer turns ratio, D is the duty cycle, and I_{LOAD} is the maximum load current (and ΣI_{LOAD} is the sum of the maximum load currents for multiple-output flyback regulators). The duty cycle is given by:

Boost:

$$D = \frac{V_{OUT} + V_F - V_{IN}}{V_{OUT} + V_F - V_{SAT}} \approx \frac{V_{OUT} - V_{IN}}{V_{OUT}}$$

Flyback:

$$D = \frac{V_{OUT} + V_F}{N(V_{IN} - V_{SAT}) + V_{OUT} + V_F} \approx \frac{V_{OUT}}{N(V_{IN}) + V_{OUT}}$$

where V_F is the forward biased voltage of the diode and is typically 0.5V for Schottky diodes and 0.8V for fast recovery diodes. V_{SAT} is the switch saturation voltage and can be found in the Characteristic Curves.

When no heat sink is used, the junction temperature rise is:

$$\Delta T_J = P_D \times \theta_{JA}$$

Adding the junction temperature rise to the maximum ambient temperature gives the actual operating junction temperature:

$$T_J = \Delta T_J + T_A$$

If the operating junction temperature exceeds the maximum junction temperature in item 3 above, then a heat sink is required. When using a heat sink, the junction temperature rise can be determined by the following:

$$\Delta T_J = P_D \times (\theta_{JC} + \theta_{Interface} + \theta_{Heat\ Sink})$$

Again, the operating junction temperature will be:

$$T_J = \Delta T_J + T_A$$

Application Hints (Continued)

As before, if the maximum junction temperature is exceeded, a larger heat sink is required (one that has a lower thermal resistance).

Included in the **Switchers Made Simple**[®] design software is a more precise (non-linear) thermal model that can be used to determine junction temperature with different input-output parameters or different component values. It can also calculate the heat sink thermal resistance required to maintain the regulator junction temperature below the maximum operating temperature.

*To further simplify the flyback regulator design procedure, National Semiconductor is making available computer design software. **Switchers Made Simple**[®] software is available on a (3½") diskette for IBM compatible computers from a National Semiconductor sales office in your area or the National Semiconductor Customer Response Center (1-800-272-9959).*

European Magnetic Vendor Contacts

Please contact the following addresses for details of local distributors or representatives:

Coilcraft

21 Napier Place
Wardpark North
Cumbernauld, Scotland G68 0LL
Phone: + 44 1236 730 595
Fax: + 44 1236 730 627

Pulse Engineering

Dunmore Road
Tuam
Co. Galway, Ireland
Phone: + 353 93 24 107
Fax: + 353 93 24 459

Physical Dimensions inches (millimeters)

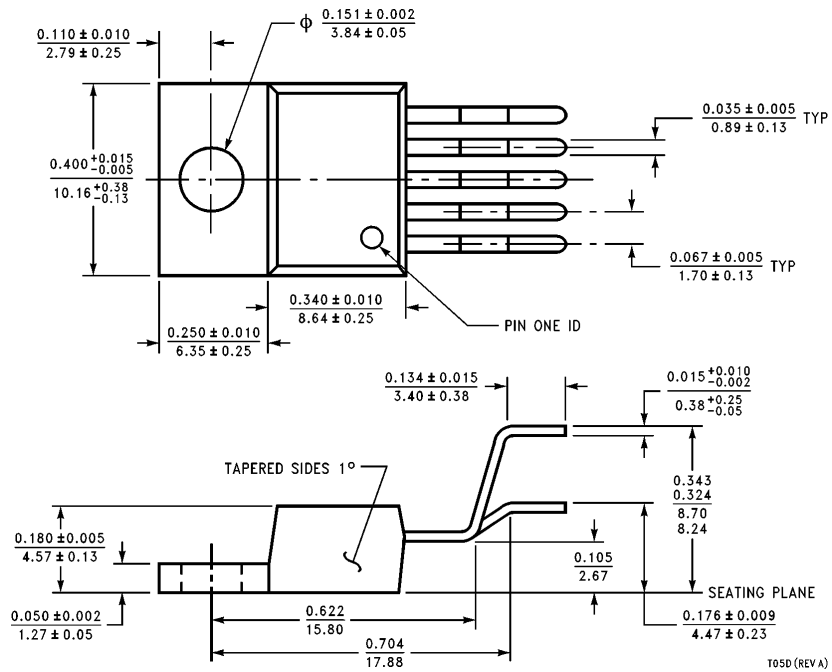

T05D (REV A)

**Order Number LM2587T-3.3, LM2587T-5.0,
LM2587T-12 or LM2587T-ADJ
NS Package Number T05D**

Physical Dimensions inches (millimeters) (Continued)

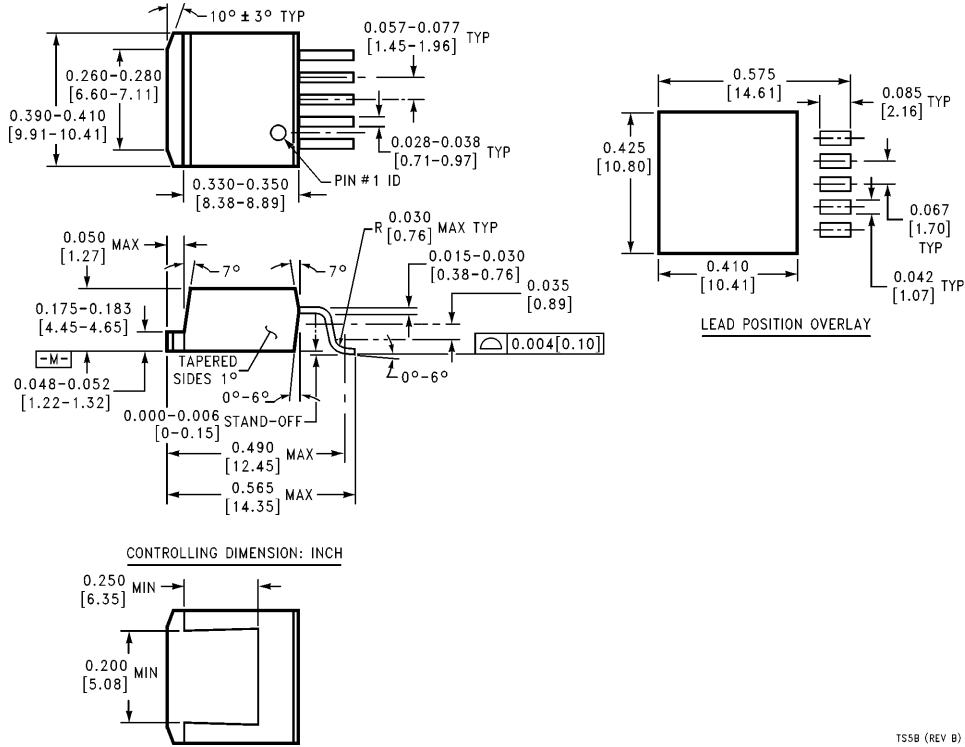

**Order Number LM2587S-3.3, LM2587S-5.0,
LM2587S-12 or LM2587S-ADJ
NS Package Number TS5B**

TSSB (REV B)

LIFE SUPPORT POLICY

NATIONAL'S PRODUCTS ARE NOT AUTHORIZED FOR USE AS CRITICAL COMPONENTS IN LIFE SUPPORT DEVICES OR SYSTEMS WITHOUT THE EXPRESS WRITTEN APPROVAL OF THE PRESIDENT OF NATIONAL SEMICONDUCTOR CORPORATION. As used herein:

1. Life support devices or systems are devices or systems which, (a) are intended for surgical implant into the body, or (b) support or sustain life, and whose failure to perform, when properly used in accordance with instructions for use provided in the labeling, can be reasonably expected to result in a significant injury to the user.
2. A critical component is any component of a life support device or system whose failure to perform can be reasonably expected to cause the failure of the life support device or system, or to affect its safety or effectiveness.



National Semiconductor Corporation
1111 West Bardin Road
Arlington, TX 76017
Tel: 1(800) 272-9959
Fax: 1(800) 737-7018

National Semiconductor Europe
Fax: +49 (0) 180-530 85 86
Email: europe.support@nsc.com
Deutsch Tel: +49 (0) 180-530 85 85
English Tel: +49 (0) 180-532 78 32
Français Tel: +49 (0) 180-532 93 58
Italiano Tel: +49 (0) 180-534 16 80

National Semiconductor Hong Kong Ltd.
13th Floor, Straight Block,
Ocean Centre, 5 Canton Rd.
Tsimshatsui, Kowloon
Hong Kong
Tel: (852) 2737-1600
Fax: (852) 2736-9960

National Semiconductor Japan Ltd.
Tel: 81-043-299-2308
Fax: 81-043-299-2408

<http://www.national.com>