

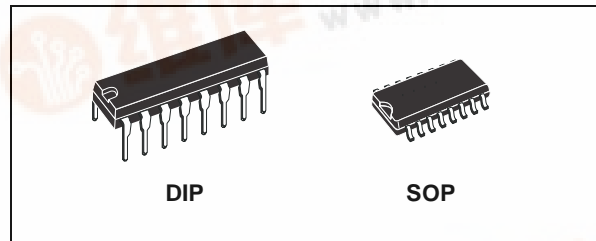

HCF4051B

SINGLE 8-CHANNEL ANALOG MULTIPLEXER/DEMULTIPLEXER

- LOW "ON" RESISTANCE : 125Ω (Typ.) OVER 15V p.p SIGNAL-INPUT RANGE FOR $V_{DD} - V_{EE} = 15V$
- HIGH "OFF" RESISTANCE : CHANNEL LEAKAGE $\pm 100pA$ (Typ.) at $V_{DD} - V_{EE} = 18V$
- BINARY ADDRESS DECODING ON CHIP
- HIGH DEGREE OF LINEARITY : $< 0.5\%$ DISTORTION TYP. at $f_{IS} = 1KHz$, $V_{IS} = 5 V_{pp}$, $V_{DD} - V_{SS} \geq 10V$, $R_L = 10K\Omega$
- VERY LOW QUIESCENT POWER DISSIPATION UNDER ALL DIGITAL CONTROL INPUT AND SUPPLY CONDITIONS : $0.2 \mu W$ (Typ.) at $V_{DD} - V_{SS} = V_{DD} - V_{EE} = 10V$
- MATCHED SWITCH CHARACTERISTICS : $R_{ON} = 5\Omega$ (Typ.) FOR $V_{DD} - V_{EE} = 15V$
- WIDE RANGE OF DIGITAL AND ANALOG SIGNAL LEVELS : DIGITAL 3 to 20, ANALOG TO 20V p.p.
- QUIESCENT CURRENT SPECIFIED UP TO 20V
- 5V, 10V AND 15V PARAMETRIC RATINGS
- INPUT LEAKAGE CURRENT $I_l = 100nA$ (MAX) AT $V_{DD} = 18V$ $T_A = 25^\circ C$
- 100% TESTED FOR QUIESCENT CURRENT
- MEETS ALL REQUIREMENTS OF JEDEC JESD13B " STANDARD SPECIFICATIONS FOR DESCRIPTION OF B SERIES CMOS DEVICES"



ORDER CODES

PACKAGE	TUBE	T & R
DIP	HCF4051BEY	
SOP	HCF4051BM1	HCF4051M013TR

DESCRIPTION

The HCF4051B is a monolithic integrated circuit fabricated in Metal Oxide Semiconductor technology available in DIP and SOP packages. The HCF4051B analog multiplexer/demultiplexer is a digitally controlled analog switch having low ON impedance and very low OFF leakage current. This multiplexer circuit dissipate extremely low quiescent power over the full $V_{DD} - V_{SS}$ and $V_{DD} - V_{EE}$ supply voltage range, independent of the logic state of the control signals. When a logic "1" is present at the inhibit input terminal all channel are off. This device is a single 8-channel multiplexer having three binary control inputs, A, B, and C, and an inhibit input. The three binary signals select 1 of 8 channels to be turned on, and connect one of the 8 inputs to the output.

PIN CONNECTION

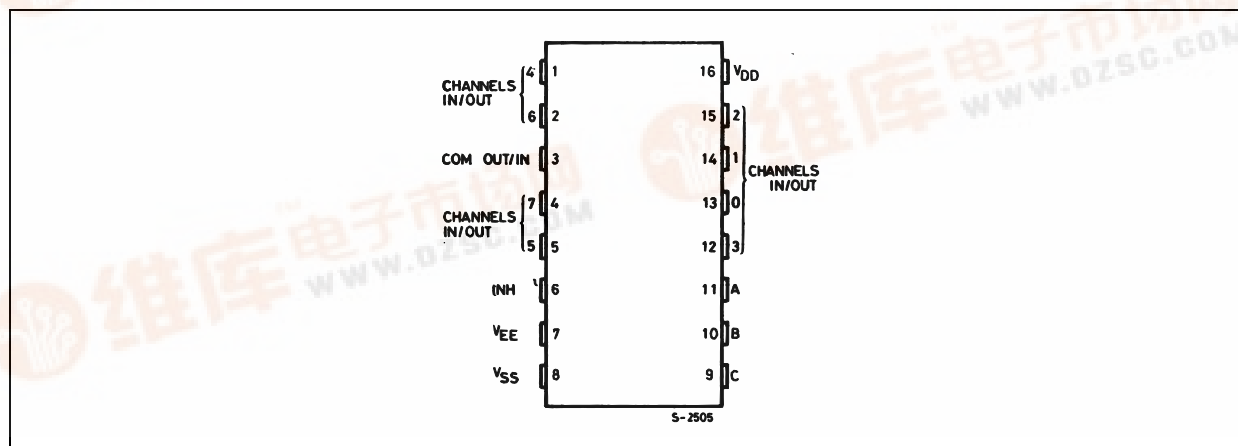

HCF4051B

INPUT EQUIVALENT CIRCUIT

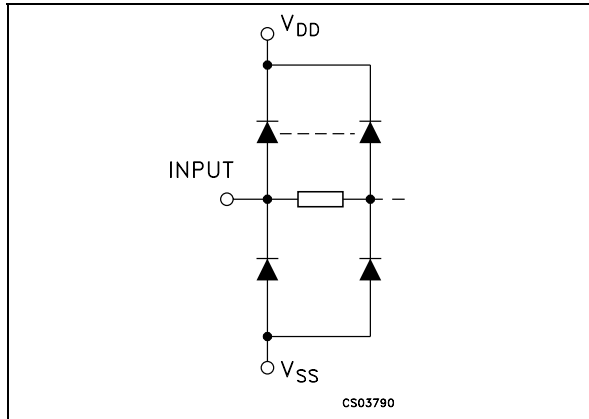

PIN DESCRIPTION

PIN No	SYMBOL	NAME AND FUNCTION
11, 10, 9	A, B, C	Binary Control Inputs
6	INH	Inhibit Inputs
13, 14, 15, 12, 1, 5, 2, 4	0 to 7 CHANNEL IN/OUT	Independent inputs/outputs
3	COM OUT/IN	Common Output/Input
7	V _{EE}	Supply Voltage
8	V _{SS}	Negative Supply Voltage
16	V _{DD}	Positive Supply Voltage

TRUTH TABLE

INPUT STATES				"ON" CHANNEL (S)
INHIBIT	C	B	A	
0	0	0	0	0
0	0	0	1	1
0	0	1	0	2
0	0	1	1	3
0	1	0	0	4
0	1	0	1	5
0	1	1	0	6
0	1	1	1	7
1	X	X	X	NONE

FUNCTIONAL DIAGRAM

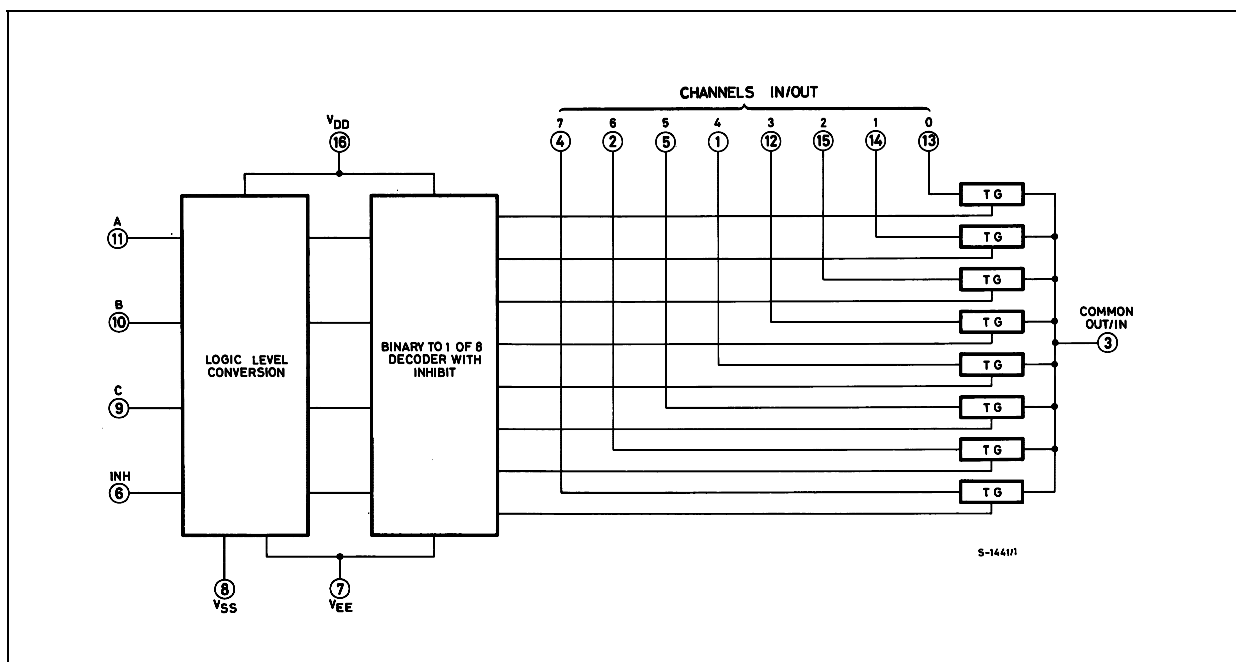

ABSOLUTE MAXIMUM RATINGS

Symbol	Parameter	Value	Unit
V_{DD}	Supply Voltage	-0.5 to +22	V
V_I	DC Input Voltage	-0.5 to $V_{DD} + 0.5$	V
I_I	DC Input Current	± 10	mA
P_D	Power Dissipation per Package	500 (*)	mW
	Power Dissipation per Output Transistor	100	mW
T_{op}	Operating Temperature	-55 to +125	°C
T_{stg}	Storage Temperature	-65 to +150	°C

Absolute Maximum Ratings are those values beyond which damage to the device may occur. Functional operation under these conditions is not implied.

All voltage values are referred to V_{SS} pin voltage.

(*) 500mW at 65 °C; derate to 300mW by 10mW/°C from 65°C to 85°C

RECOMMENDED OPERATING CONDITIONS

Symbol	Parameter	Value	Unit
V_{DD}	Supply Voltage	3 to 20	V
V_I	Input Voltage	0 to V_{DD}	V
T_{op}	Operating Temperature	-55 to 125	°C

HCF4051B

DC SPECIFICATIONS

Symbol	Parameter	Test Condition				Value						Unit	
		V _{IS} (V)	V _{EE} (V)	V _{SS} (V)	V _{DD} (V)	T _A = 25°C			-40 to 85°C		-55 to 125°C		
						Min.	Typ.	Max.	Min.	Max.	Min.		Max.
I _L	Quiescent Device Current (all switches ON or all switches OFF)				5		0.04	5		150		150	μA
					10		0.04	10		300		300	
					15		0.04	20		600		600	
					20		0.08	100		3000		3000	
SWITCH													
R _{ON}	Resistance	0 ≤ V _I ≤ V _{DD}	0	0	5		470	1050		1200		1200	Ω
					10		180	400		520		520	
					15		125	280		360		360	
Δ _{ON}	Resistance Δ _{RON} (between any 2 of 4 switches)	0 ≤ V _I ≤ V _{DD}	0	0	5		10						Ω
					10		10						
					15		5						
OFF*	Channel Leakage Current (All Channel OFF) (COMMON O/I)		0	0	18		±0.1	100		1000		1000	nA
OFF*	Channel Leakage Current (Any Channel OFF)		0	0	18		±0.1	100		1000		1000	nA
C _I	Input Capacitance		-5	-5	5		5						pF
C _O	Output Capacitance						30						
C _{IO}	Feedthrough						0.2						
CONTROL (Address or Inhibit)													
V _{IL}	Input Low Voltage	= V _{DD} thru 1KΩ	V _{EE} = V _{SS} R _L = 1KΩ to V _{SS} I _{IS} < 2μA (on all OFF channels)	5			1.5		1.5		1.5		V
				10			3		3		3		
				15			4		4		4		
V _{IH}	Input High Voltage	= V _{DD} thru 1KΩ	V _{EE} = V _{SS} R _L = 1KΩ to V _{SS} I _{IS} < 2μA (on all OFF channels)	5	3.5			3.5		3.5			V
				10	7			7		7			
				15	11			11		11			
I _{IH} , I _{IL}	Input Leakage Current		V _I = 0/18V		18		±10 ⁻³	±0.1		±1		±1	μA
C _I	Input Capacitance						5	7.5					pF

* Determined by minimum feasible leakage measurement for automating testing.

DYNAMIC ELECTRICAL CHARACTERISTICS ($T_{amb} = 25^{\circ}\text{C}$, $C_L = 50\text{pF}$, all input square wave rise and fall time = 20 ns)

Parameter	Test Condition						Value			Unit	
	V_{EE} (V)	R_L (K Ω)	f_i (KHz)	V_I (V)	V_{SS} (V)	V_{DD} (V)	Min.	Typ.	Max.		
Propagation Delay Time (signal input to output)		200		V_{DD} 		5		30	60	ns	
						10		15	30		
						15		11	20		
Frequency Response Channel "ON" (sine wave input) at $20 \log V_O/V_I = -3\text{dB}$	$= V_{SS}$	1		5(*)		10	V_O at Common OUT/IN	20		MHz	
							V_O at any channel	60			
Feedthrough (all channels OFF) at $20 \log V_O/V_I = -40\text{dB}$	$= V_{SS}$	1		5(*)		10	V_O at Common OUT/IN	12		MHz	
							V_O at any channel	8			
Frequency Signal Crosstalk at $20 \log V_O/V_I = -40\text{dB}$	$= V_{SS}$	1		5(*)		10	Between any 2 channels	3		MHz	
Sine Wave Distortion $f_{IS} = 1\text{KHz}$ Sine Wave	$= V_{SS}$	10	1	2(*)		5		0.3		%	
				3(*)		10		0.2			
				5(*)		15		0.12			
CONTROL (Address or Inhibit)											
Propagation Delay: Address to Signal OUT (Channels ON or OFF)	0					0		360	720	ns	
	0					0		10	160		320
	0					0		15	120		240
	-5					0		5	225		450
Propagation Delay: Inhibit to Signal OUT (Channel turning ON)	0	1				0		360	720	ns	
	0					0		10	160		320
	0					0		15	120		240
	-10					0		5	200		400
Propagation Delay: Inhibit to Signal OUT (Channel turning OFF)	0	10				5		200	450	ns	
	0					10		90	210		
	0					15		70	160		
	-10					5		130	300		
Address or Inhibit to Signal Crosstalk	0	10 ⁽¹⁾			0	10	$V_C = V_{DD} - V_{SS}$ (square wave)	65		mV peak	

(1) Both ends of channel.

* Peak to Peak voltage symmetrical about $(V_{DD} - V_{EE}) / 2$

HCF4051B

TYPICAL BIAS VOLTAGES

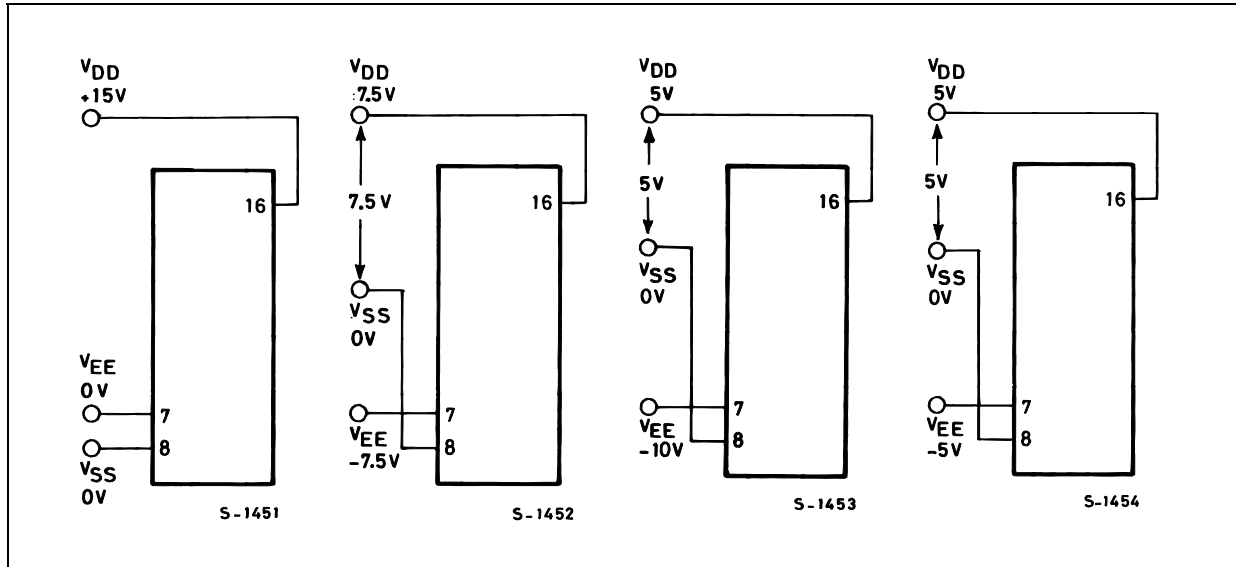

The ADDRESS (digital-control inputs) and INHIBIT logic levels are : "0"= V_{SS} and "1"= V_{DD} . The analog signal (through the TG) may swing from V_{EE} to V_{DD}

SPECIAL CONSIDERATIONS

Control of analog signals up to 20V peak to peak can be achieved by digital signal amplitudes of 4.5 to 20V (if $V_{DD} - V_{SS} = 3V$, a $V_{DD} - V_{EE}$ of up to 13V can be controlled; for $V_{DD} - V_{EE}$ level differences above 13V, a $V_{DD} - V_{SS}$ of at least 4.5V is required. For example, if $V_{DD} = +5$, $V_{SS} = 0$, and $V_{EE} = -13.5$, analog signals from -13.5V to 4.5V can be controlled by digital inputs of 0 to 4.5V. In

certain applications, the external load resistor current may include both V_{DD} and signal-line components. To avoid drawing V_{DD} current when switch current flows into the transmission gate inputs, the voltage drop across the bidirectional switch must not exceed 0,8V (calculated from R_{ON} values shown in DC SPECIFICATIONS). No V_{DD} current will flow through R_L if the switch current flows into lead 3.

TEST CIRCUIT

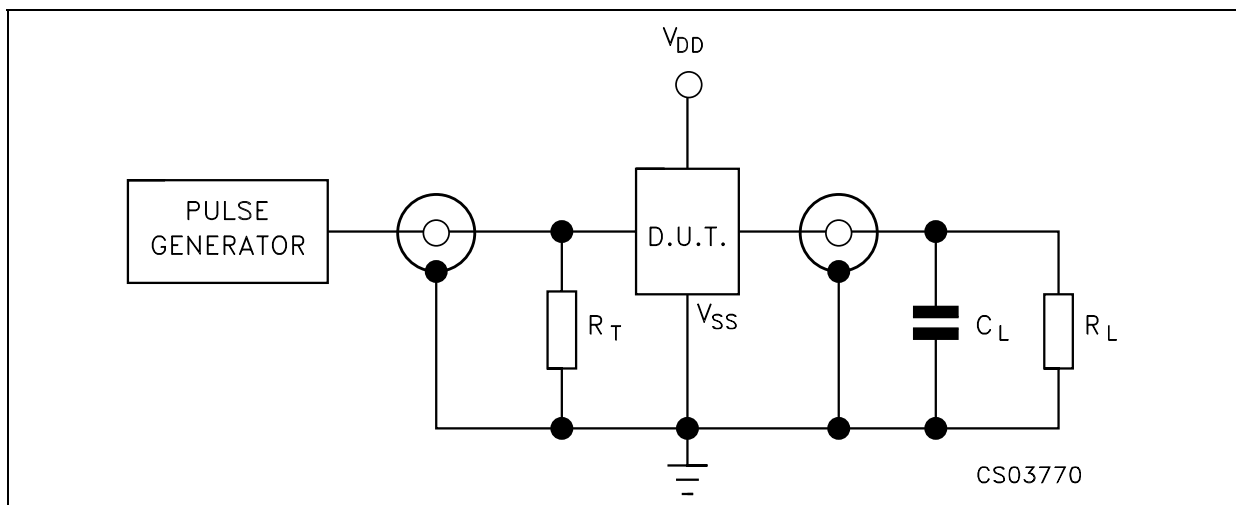

$C_L = 50pF$ or equivalent (includes jig and probe capacitance)
 $R_L = 200K\Omega$
 $R_T = Z_{OUT}$ of pulse generator (typically 50Ω)

WAVEFORM 1 : CHANNEL BEING TURNED ON ($R_L = 1K\Omega$, $f=1MHz$; 50% duty cycle)

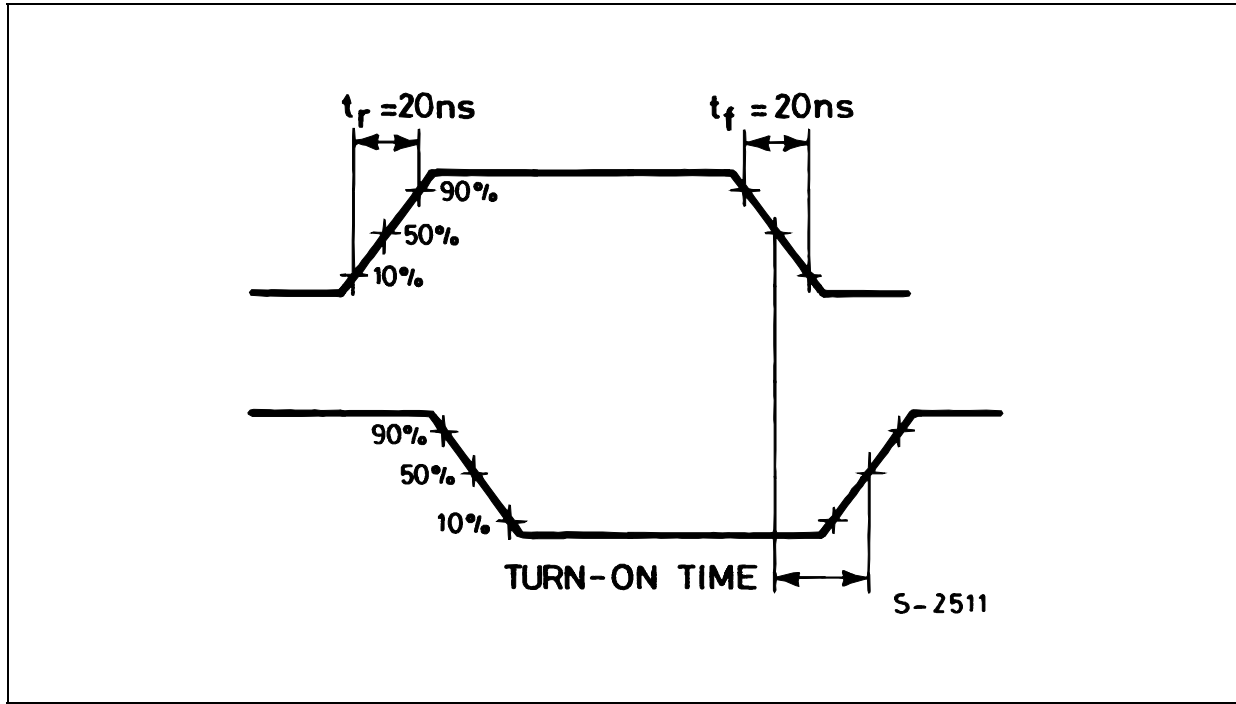

WAVEFORM 2 : CHANNEL BEING TURNED OFF ($R_L = 1K\Omega$, $f=1MHz$; 50% duty cycle)

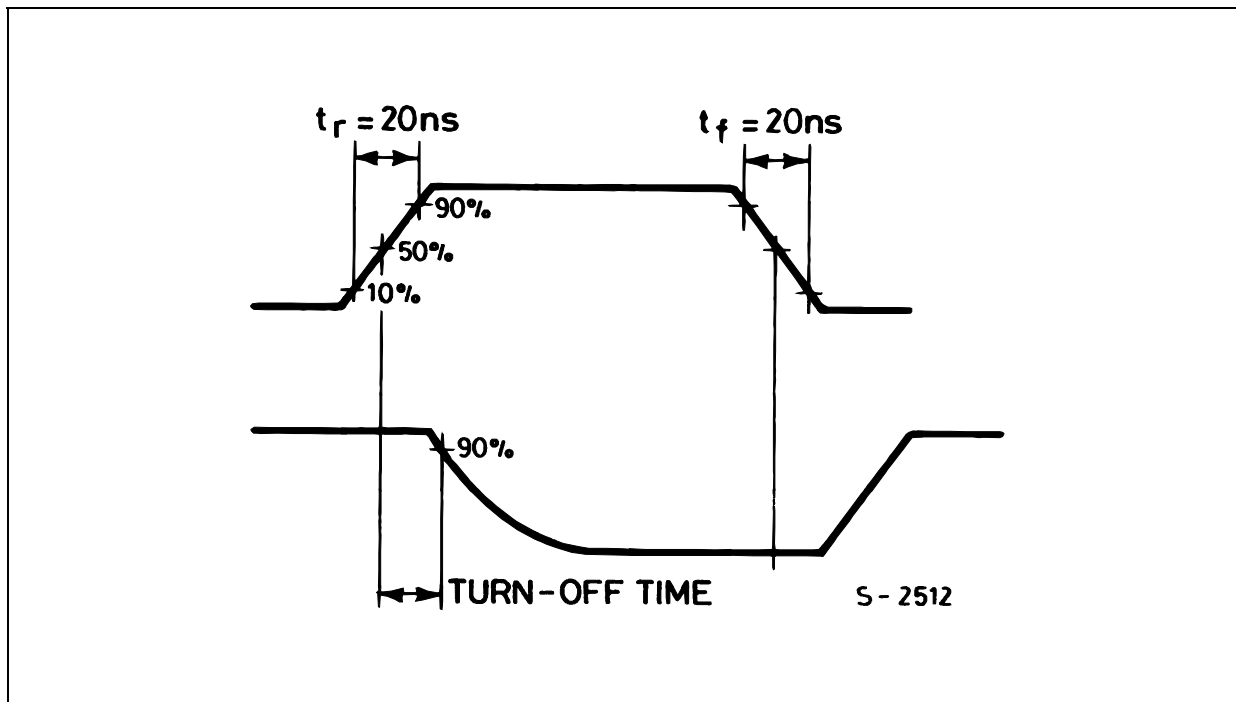

HCF4051B

Plastic DIP-16 (0.25) MECHANICAL DATA

DIM.	mm.			inch		
	MIN.	TYP.	MAX.	MIN.	TYP.	MAX.
a1	0.51			0.020		
B	0.77		1.65	0.030		0.065
b		0.5			0.020	
b1		0.25			0.010	
D			20			0.787
E		8.5			0.335	
e		2.54			0.100	
e3		17.78			0.700	
F			7.1			0.280
l			5.1			0.201
L		3.3			0.130	
Z			1.27			0.050

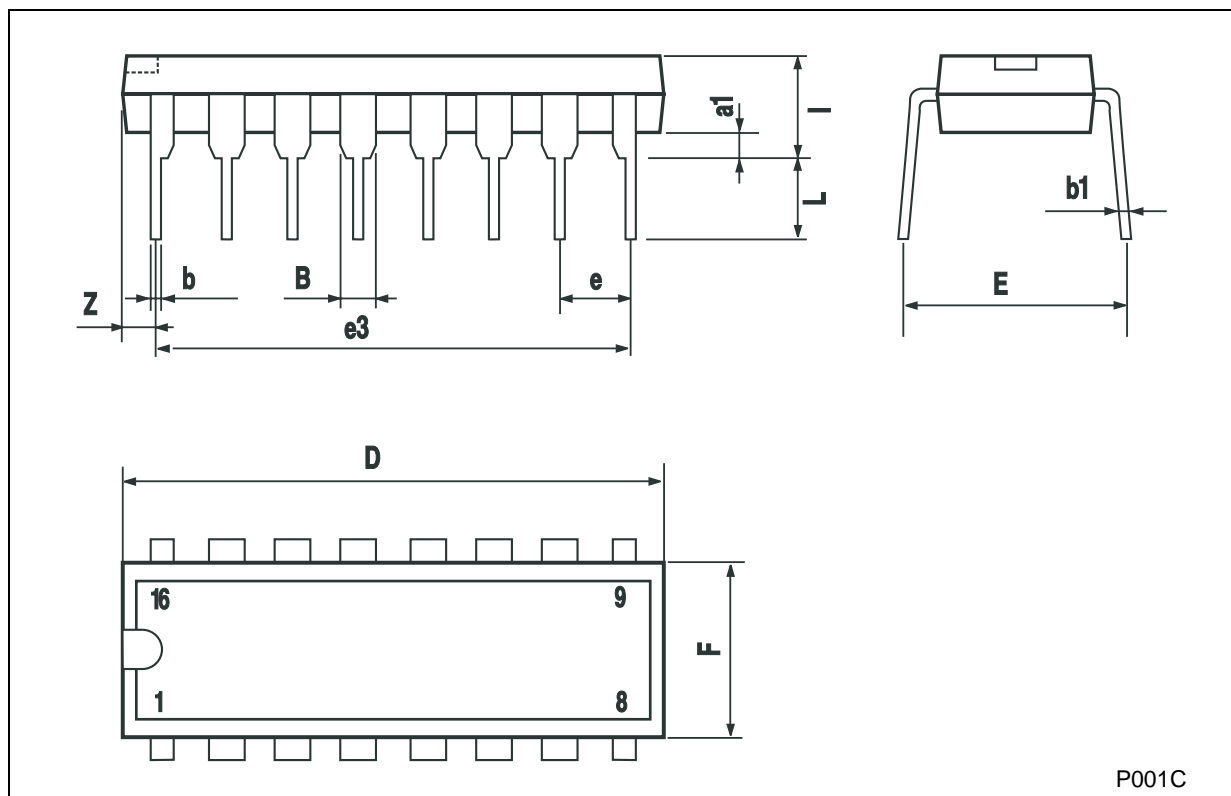

P001C

SO-16 MECHANICAL DATA

DIM.	mm.			inch		
	MIN.	TYP	MAX.	MIN.	TYP.	MAX.
A			1.75			0.068
a1	0.1		0.2	0.003		0.007
a2			1.65			0.064
b	0.35		0.46	0.013		0.018
b1	0.19		0.25	0.007		0.010
C		0.5			0.019	
c1	45° (typ.)					
D	9.8		10	0.385		0.393
E	5.8		6.2	0.228		0.244
e		1.27			0.050	
e3		8.89			0.350	
F	3.8		4.0	0.149		0.157
G	4.6		5.3	0.181		0.208
L	0.5		1.27	0.019		0.050
M			0.62			0.024
S	8° (max.)					

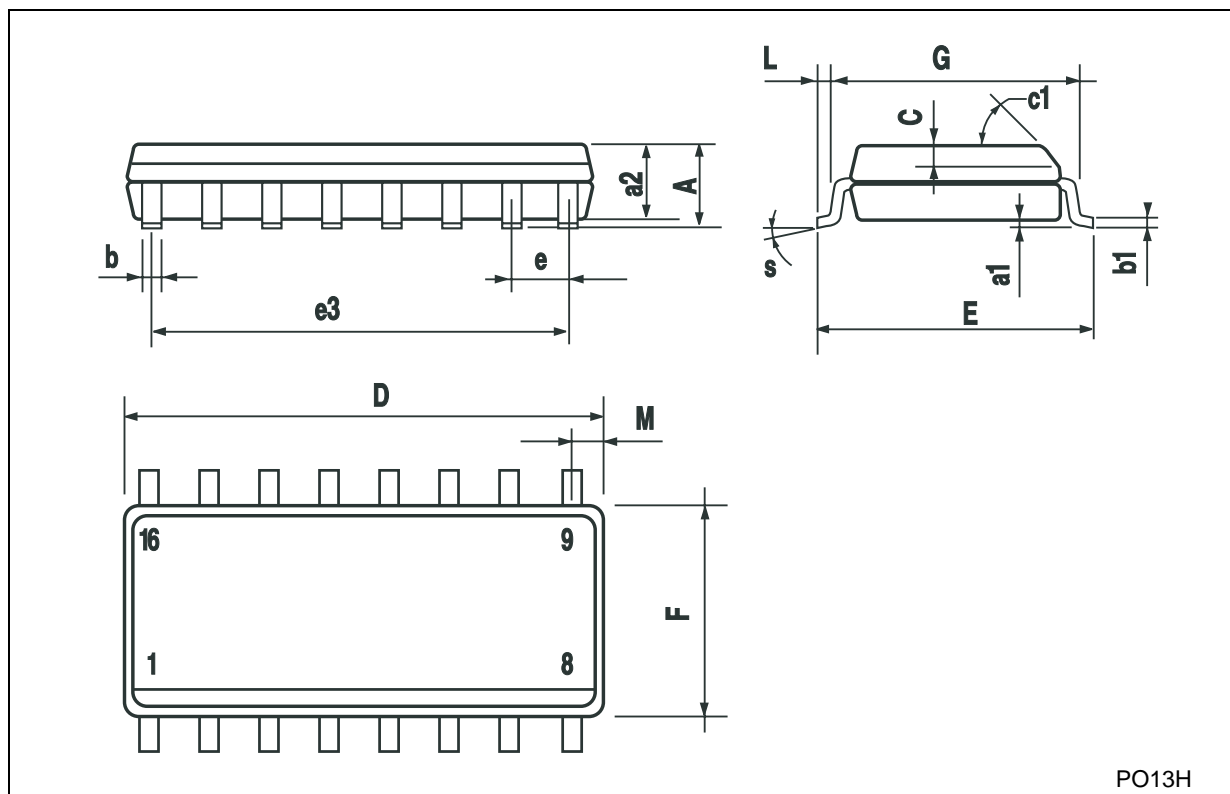

PO13H

Information furnished is believed to be accurate and reliable. However, STMicroelectronics assumes no responsibility for the consequences of use of such information nor for any infringement of patents or other rights of third parties which may result from its use. No license is granted by implication or otherwise under any patent or patent rights of STMicroelectronics. Specifications mentioned in this publication are subject to change without notice. This publication supersedes and replaces all information previously supplied. STMicroelectronics products are not authorized for use as critical components in life support devices or systems without express written approval of STMicroelectronics.

© The ST logo is a registered trademark of STMicroelectronics

© 2002 STMicroelectronics - Printed in Italy - All Rights Reserved
STMicroelectronics GROUP OF COMPANIES

Australia - Brazil - Canada - China - Finland - France - Germany - Hong Kong - India - Israel - Italy - Japan - Malaysia - Malta - Morocco
Singapore - Spain - Sweden - Switzerland - United Kingdom - United States.

© <http://www.st.com>