

- 10-Bit-Resolution A/D Converter
- Inherent Sample and Hold
- Total Unadjusted Error . . .  $\pm 1$  LSB Max
- On-Chip System Clock
- Terminal Compatible With TLC549 and TLV1549
- CMOS Technology

**description**

The TLC1549C, TLC1549I, and TLC1549M are 10-bit, switched-capacitor, successive-approximation analog-to-digital converters. These devices have two digital inputs and a 3-state output [chip select ( $\overline{CS}$ ), input-output clock (I/O CLOCK), and data output (DATA OUT)] that provide a three-wire interface to the serial port of a host processor.

The sample-and-hold function is automatic. The converter incorporated in these devices features differential high-impedance reference inputs that facilitate ratiometric conversion, scaling, and isolation of analog circuitry from logic and supply noise. A switched-capacitor design allows low-error conversion over the full operating free-air temperature range.

The TLC1549C is characterized for operation from 0°C to 70°C. The TLC1549I is characterized for operation from -40°C to 85°C. The TLC1549M is characterized for operation over the full military temperature range of -55°C to 125°C.

**D, JG, OR P PACKAGE (TOP VIEW)**

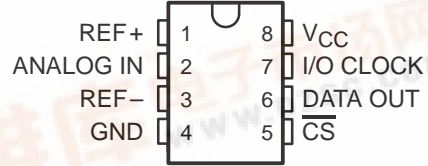

**FK PACKAGE (TOP VIEW)**

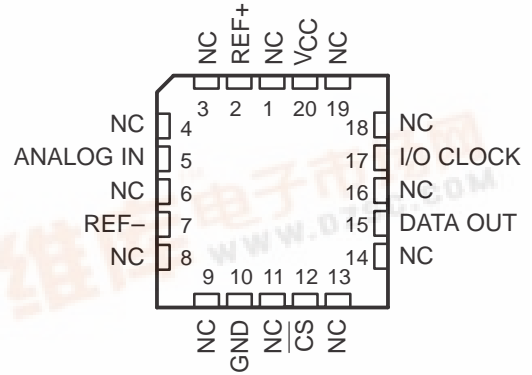

NC – No internal connection

**AVAILABLE OPTIONS**

T <sub>A</sub>	PACKAGE			
	SMALL OUTLINE (D)	CHIP CARRIER (FK)	CERAMIC DIP (JG)	PLASTIC DIP (P)
0°C to 70°C	TLC1549CD	—	—	TLC1549CP
-40°C to 85°C	TLC1549ID	—	—	TLC1549IP
-55°C to 125°C	—	TLC1549MFK	TLC1549MJG	—

Please be aware that an important notice concerning availability, standard warranty, and use in critical applications of Texas Instruments semiconductor products and disclaimers thereto appears at the end of this data sheet.



PRODUCTION DATA information is current as of publication date. Products conform to specifications per the terms of Texas Instruments standard warranty. Production processing does not necessarily include testing of all parameters.



# TLC1549C, TLC1549I, TLC1549M

## 10-BIT ANALOG-TO-DIGITAL CONVERTERS WITH SERIAL CONTROL

SLAS059C – DECEMBER 1992 – REVISED MARCH 1995

### functional block diagram

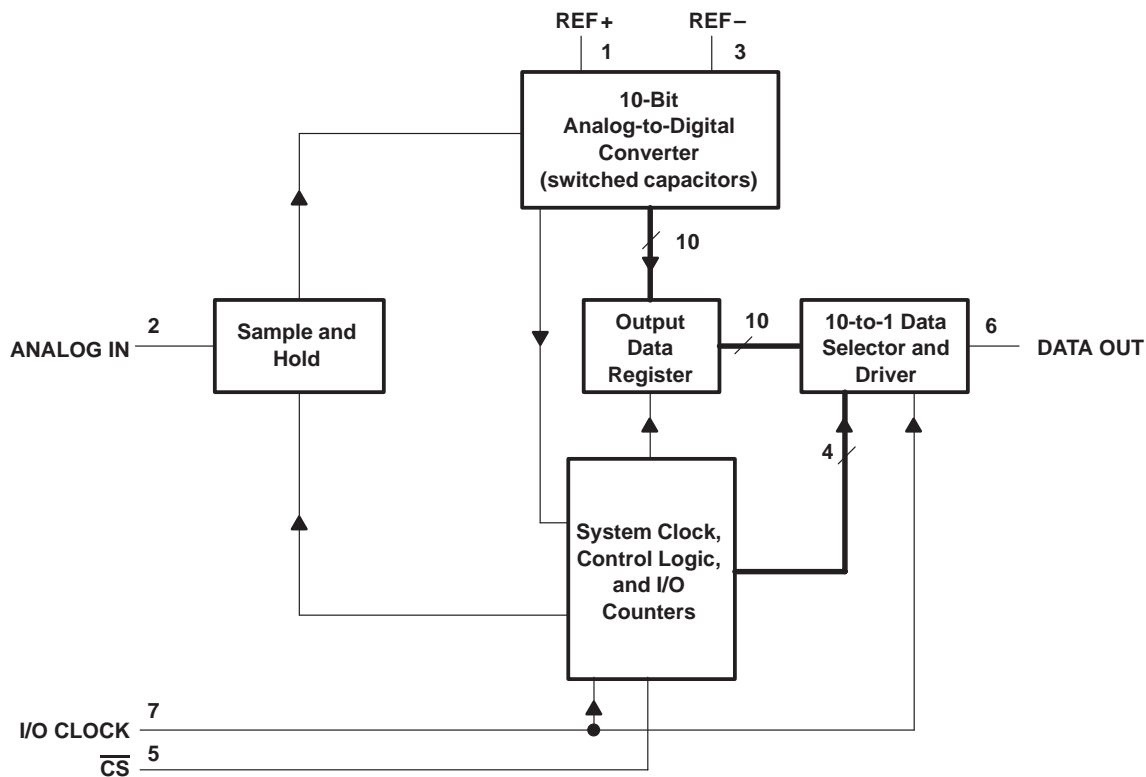

Terminal numbers shown are for the D, JG, and P packages only.

### typical equivalent inputs

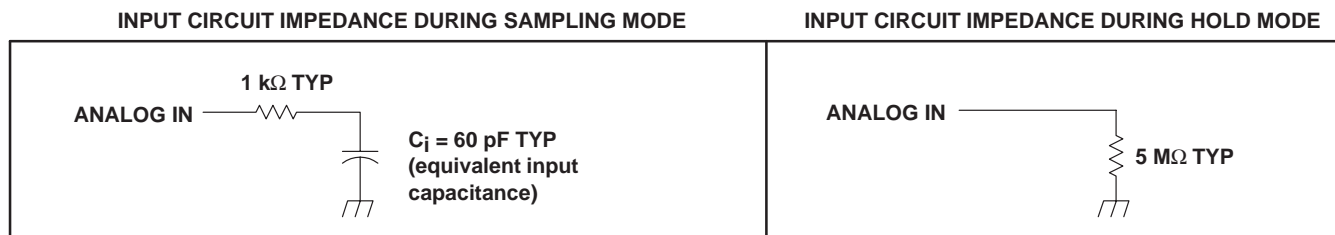

**TLC1549C, TLC1549I, TLC1549M**  
**10-BIT ANALOG-TO-DIGITAL CONVERTERS**  
**WITH SERIAL CONTROL**

SLAS059C – DECEMBER 1992 – REVISED MARCH 1995

**Terminal Functions**

TERMINAL NAME	NO.	I/O	DESCRIPTION
ANALOG IN	2	I	Analog signal input. The driving source impedance should be $\leq 1 \text{ k}\Omega$ . The external driving source to ANALOG IN should have a current capability $\geq 10 \text{ mA}$ .
$\overline{\text{CS}}$	5	I	Chip select. A high-to-low transition on $\overline{\text{CS}}$ resets the internal counters and controls and enables DATA OUT and I/O CLOCK within a maximum of a setup time plus two falling edges of the internal system clock. A low-to-high transition disables I/O CLOCK within a setup time plus two falling edges of the internal system clock.
DATA OUT	6	O	This 3-state serial output for the A/D conversion result is in the high-impedance state when $\overline{\text{CS}}$ is high and active when $\overline{\text{CS}}$ is low. With a valid chip select, DATA OUT is removed from the high-impedance state and is driven to the logic level corresponding to the MSB value of the previous conversion result. The next falling edge of I/O CLOCK drives DATAOUT to the logic level corresponding to the next most significant bit, and the remaining bits are shifted out in order with the LSB appearing on the ninth falling edge of I/O CLOCK. On the tenth falling edge of I/O CLOCK, DATA OUT is driven to a low logic level so that serial interface data transfers of more than ten clocks produce zeroes as the unused LSBs.
GND	4		The ground return for internal circuitry. Unless otherwise noted, all voltage measurements are with respect to GND.
I/O CLOCK	7	I	Input/output clock. I/O CLOCK receives the serial I/O CLOCK input and performs the following three functions: 1) On the third falling edge of I/O CLOCK, the analog input voltage begins charging the capacitor array and continues to do so until the tenth falling edge of I/O CLOCK. 2) It shifts the nine remaining bits of the previous conversion data out on DATA OUT. 3) It transfers control of the conversion to the internal state controller on the falling edge of the tenth clock.
REF +	1	I	The upper reference voltage value (nominally $V_{\text{CC}}$ ) is applied to REF+. The maximum input voltage range is determined by the difference between the voltage applied to REF + and the voltage applied to REF –.
REF –	3	I	The lower reference voltage value (nominally ground) is applied to REF –.
$V_{\text{CC}}$	8		Positive supply voltage

**detailed description**

With chip select ( $\overline{\text{CS}}$ ) inactive (high), I/O CLOCK is initially disabled and DATA OUT is in the high impedance state. When the serial interface takes  $\overline{\text{CS}}$  active (low), the conversion sequence begins with the enabling of I/O CLOCK and the removal of DATA OUT from the high-impedance state. The serial interface then provides the I/O CLOCK sequence to I/O CLOCK and receives the previous conversion result from DATA OUT. I/O CLOCK receives an input sequence that is between 10 and 16 clocks long from the host serial interface. The first ten I/O clocks provide the control timing for sampling the analog input.

There are six basic serial interface timing modes that can be used with the TLC1549. These modes are determined by the speed of I/O CLOCK and the operation of  $\overline{\text{CS}}$  as shown in Table 1. These modes are (1) a fast mode with a 10-clock transfer and  $\overline{\text{CS}}$  inactive (high) between transfers, (2) a fast mode with a 10-clock transfer and  $\overline{\text{CS}}$  active (low) continuously, (3) a fast mode with an 11- to 16-clock transfer and  $\overline{\text{CS}}$  inactive (high) between transfers, (4) a fast mode with a 16-bit transfer and  $\overline{\text{CS}}$  active (low) continuously, (5) a slow mode with an 11- to 16-clock transfer and  $\overline{\text{CS}}$  inactive (high) between transfers, and (6) a slow mode with a 16-clock transfer and  $\overline{\text{CS}}$  active (low) continuously.

The MSB of the previous conversion appears on DATA OUT on the falling edge of  $\overline{\text{CS}}$  in mode 1, mode 3, and mode 5, within 21  $\mu\text{s}$  from the falling edge of the tenth I/O CLOCK in mode 2 and mode 4, and following the sixteenth clock falling edge in mode 6. The remaining nine bits are shifted out on the next nine falling edges of I/O CLOCK. Ten bits of data are transmitted to the host serial interface through DATA OUT. The number of serial clock pulses used also depends on the mode of operation, but a minimum of ten clock pulses is required for conversion to begin. On the tenth clock falling edge, the internal logic takes DATA OUT low to ensure that the remaining bit values are zero if the I/O CLOCK transfer is more than ten clocks long.

Table 1 lists the operational modes with respect to the state of  $\overline{\text{CS}}$ , the number of I/O serial transfer clocks that can be used, and the timing on which the MSB of the previous conversion appears at the output.

# TLC1549C, TLC1549I, TLC1549M

## 10-BIT ANALOG-TO-DIGITAL CONVERTERS

### WITH SERIAL CONTROL

SLAS059C – DECEMBER 1992 – REVISED MARCH 1995

#### detailed description

**Table 1. Mode Operation**

MODES		$\overline{CS}$	NO. OF I/O CLOCKS	MSB AT Terminal 6†	TIMING DIAGRAM
Fast Modes	Mode 1	High between conversion cycles	10	$\overline{CS}$ falling edge	Figure 6
	Mode 2	Low continuously	10	Within 21 $\mu$ s	Figure 7
	Mode 3	High between conversion cycles	11 to 16‡	$\overline{CS}$ falling edge	Figure 8
	Mode 4	Low continuously	16‡	Within 21 $\mu$ s	Figure 9
Slow Modes	Mode 5	High between conversion cycles	11 to 16‡	$\overline{CS}$ falling edge	Figure 10
	Mode 6	Low continuously	16‡	16th clock falling edge	Figure 11

† This timing also initiates serial interface communication.

‡ No more than 16 clocks should be used.

All the modes require a minimum period of 21  $\mu$ s after the falling edge of the tenth I/O CLOCK before a new transfer sequence can begin. During a serial I/O CLOCK data transfer,  $\overline{CS}$  must be active (low) so that I/O CLOCK is enabled. When  $\overline{CS}$  is toggled between data transfers (modes 1, 3, and 5), the transitions at  $\overline{CS}$  are recognized as valid only if the level is maintained for a minimum period of 1.425  $\mu$ s after the transition. If the transfer is more than ten I/O clocks (modes 3, 4, 5, and 6), the rising edge of the eleventh clock must occur within 9.5  $\mu$ s after the falling edge of the tenth I/O CLOCK; otherwise, the device could lose synchronization with the host serial interface and  $\overline{CS}$  has to be toggled to restore proper operation.

#### fast modes

The TLC1549 is in a fast mode when the serial I/O CLOCK data transfer is completed within 21  $\mu$ s from the falling edge of the tenth I/O CLOCK. With a ten-clock serial transfer, the device can only run in a fast mode.

#### **mode 1: fast mode, $\overline{CS}$ inactive (high) between transfers, 10-clock transfer**

In this mode,  $\overline{CS}$  is inactive (high) between serial I/O CLOCK transfers and each transfer is ten clocks long. The falling edge of  $\overline{CS}$  begins the sequence by removing DATA OUT from the high-impedance state. The rising edge of  $\overline{CS}$  ends the sequence by returning DATA OUT to the high-impedance state within the specified delay time. Also, the rising edge of  $\overline{CS}$  disables I/O CLOCK within a setup time plus two falling edges of the internal system clock.

#### **mode 2: fast mode, $\overline{CS}$ active (low) continuously, 10-clock transfer**

In this mode,  $\overline{CS}$  is active (low) between serial I/O CLOCK transfers and each transfer is ten clocks long. After the initial conversion cycle,  $\overline{CS}$  is held active (low) for subsequent conversions. Within 21  $\mu$ s after the falling edge of the tenth I/O CLOCK, the MSB of the previous conversion appears at DATA OUT.

#### **mode 3: fast mode, $\overline{CS}$ inactive (high) between transfers, 11- to 16-clock transfer**

In this mode,  $\overline{CS}$  is inactive (high) between serial I/O CLOCK transfers and each transfer can be 11 to 16 clocks long. The falling edge of  $\overline{CS}$  begins the sequence by removing DATA OUT from the high-impedance state. The rising edge of  $\overline{CS}$  ends the sequence by returning DATA OUT to the high-impedance state within the specified delay time. Also, the rising edge of  $\overline{CS}$  disables I/O CLOCK within a setup time plus two falling edges of the internal system clock.

#### **mode 4: fast mode, $\overline{CS}$ active (low) continuously, 16-clock transfer**

In this mode,  $\overline{CS}$  is active (low) between serial I/O CLOCK transfers and each transfer must be exactly 16 clocks long. After the initial conversion cycle,  $\overline{CS}$  is held active (low) for subsequent conversions. Within 21  $\mu$ s after the falling edge of the tenth I/O CLOCK, the MSB of the previous conversion appears at DATA OUT.

#### slow modes

In a slow mode, the serial I/O CLOCK data transfer is completed after 21  $\mu$ s from the falling edge of the tenth I/O CLOCK.

TLC1549C, TLC1549I, TLC1549M  
10-BIT ANALOG-TO-DIGITAL CONVERTERS  
WITH SERIAL CONTROL

SLAS059C – DECEMBER 1992 – REVISED MARCH 1995

---

**mode 5: slow mode,  $\overline{CS}$  inactive (high) between transfers, 11- to 16-clock transfer**

In this mode,  $\overline{CS}$  is inactive (high) between serial I/O CLOCK transfers and each transfer can be 11 to 16 clocks long. The falling edge of  $\overline{CS}$  begins the sequence by removing DATA OUT from the high-impedance state. The rising edge of  $\overline{CS}$  ends the sequence by returning DATA OUT to the high-impedance state within the specified delay time. Also, the rising edge of  $\overline{CS}$  disables I/O CLOCK within a setup time plus two falling edges of the internal system clock.

**mode 6: slow mode,  $\overline{CS}$  active (low) continuously, 16-clock transfer**

In this mode,  $\overline{CS}$  is active (low) between serial I/O CLOCK transfers and each transfer must be exactly 16 clocks long. After the initial conversion cycle,  $\overline{CS}$  is held active (low) for subsequent conversions. The falling edge of the sixteenth I/O CLOCK then begins each sequence by removing DATA OUT from the low state, allowing the MSB of the previous conversion to appear immediately at DATA OUT. The device is then ready for the next 16 clock transfer initiated by the serial interface.

**analog input sampling**

Sampling of the analog input starts on the falling edge of the third I/O CLOCK, and sampling continues for seven I/O CLOCK periods. The sample is held on the falling edge of the tenth I/O CLOCK.

**converter and analog input**

The CMOS threshold detector in the successive-approximation conversion system determines each bit by examining the charge on a series of binary-weighted capacitors (see Figure 1). In the first phase of the conversion process, the analog input is sampled by closing the  $S_C$  switch and all  $S_T$  switches simultaneously. This action charges all the capacitors to the input voltage.

In the next phase of the conversion process, all  $S_T$  and  $S_C$  switches are opened and the threshold detector begins identifying bits by identifying the charge (voltage) on each capacitor relative to the reference (REF-) voltage. In the switching sequence, ten capacitors are examined separately until all ten bits are identified and then the charge-convert sequence is repeated. In the first step of the conversion phase, the threshold detector looks at the first capacitor (weight = 512). Node 512 of this capacitor is switched to the REF+ voltage, and the equivalent nodes of all the other capacitors on the ladder are switched to REF-. If the voltage at the summing node is greater than the trip point of the threshold detector (approximately one-half  $V_{CC}$ ), a bit 0 is placed in the output register and the 512-weight capacitor is switched to REF-. If the voltage at the summing node is less than the trip point of the threshold detector, a bit 1 is placed in the register and this 512-weight capacitor remains connected to REF+ through the remainder of the successive-approximation process. The process is repeated for the 256-weight capacitor, the 128-weight capacitor, and so forth down the line until all bits are determined.

With each step of the successive-approximation process, the initial charge is redistributed among the capacitors. The conversion process relies on charge redistribution to determine the bits from MSB to LSB.

# TLC1549C, TLC1549I, TLC1549M

## 10-BIT ANALOG-TO-DIGITAL CONVERTERS

### WITH SERIAL CONTROL

SLAS059C – DECEMBER 1992 – REVISED MARCH 1995

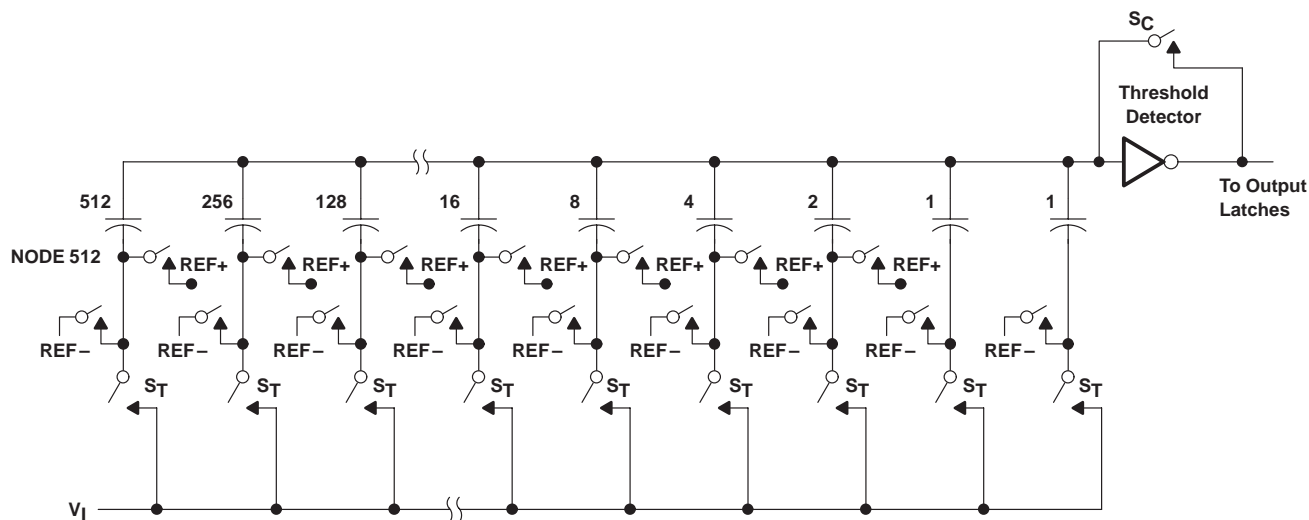

Figure 1. Simplified Model of the Successive-Approximation System

#### chip-select operation

The trailing edge of  $\overline{CS}$  starts all modes of operation, and  $\overline{CS}$  can abort a conversion sequence in any mode. A high-to-low transition on  $\overline{CS}$  within the specified time during an ongoing cycle aborts the cycle, and the device returns to the initial state (the contents of the output data register remain at the previous conversion result). Care should be exercised to prevent  $\overline{CS}$  from being taken low close to completion of conversion because the output data may be corrupted.

#### reference voltage inputs

There are two reference inputs used with the TLC1549: REF+ and REF-. These voltage values establish the upper and lower limits of the analog input to produce a full-scale and zero reading respectively. The values of REF+, REF-, and the analog input should not exceed the positive supply or be lower than GND consistent with the specified absolute maximum ratings. The digital output is at full scale when the input signal is equal to or higher than REF+ and at zero when the input signal is equal to or lower than REF-.

# TLC1549C, TLC1549I, TLC1549M

## 10-BIT ANALOG-TO-DIGITAL CONVERTERS

### WITH SERIAL CONTROL

SLAS059C – DECEMBER 1992 – REVISED MARCH 1995

#### absolute maximum ratings over operating free-air temperature range (unless otherwise noted)†

Supply voltage range, $V_{CC}$ (see Note 1): TLC1549C, TLC1549I	–0.5 V to 6.5 V
TLC1549M	–0.5 V to 6 V
Input voltage range, $V_I$ (any input)	–0.3 V to $V_{CC} + 0.3$ V
Output voltage range, $V_O$	–0.3 V to $V_{CC} + 0.3$ V
Positive reference voltage, $V_{ref+}$	$V_{CC} + 0.1$ V
Negative reference voltage, $V_{ref-}$	–0.1 V
Peak input current (any input)	$\pm 20$ mA
Peak total input current (all inputs)	$\pm 30$ mA
Operating free-air temperature range, $T_A$ : TLC1549C	0°C to 70°C
TLC1549I	–40°C to 85°C
TLC1549M	–55°C to 125°C
Storage temperature range, $T_{stg}$	–65°C to 150°C
Lead temperature 1,6 mm (1/16 inch) from the case for 10 seconds	260°C

† Stresses beyond those listed under “absolute maximum ratings” may cause permanent damage to the device. These are stress ratings only, and functional operation of the device at these or any other conditions beyond those indicated under “recommended operating conditions” is not implied. Exposure to absolute-maximum-rated conditions for extended periods may affect device reliability.

NOTE 1: All voltage values are with respect to ground with REF– and GND wired together (unless otherwise noted).

#### recommended operating conditions

		MIN	NOM	MAX	UNIT
Supply voltage, $V_{CC}$		4.5	5	5.5	V
Positive reference voltage, $V_{ref+}$ (see Note 2)		$V_{CC}$			V
Negative reference voltage, $V_{ref-}$ (see Note 2)		0			V
Differential reference voltage, $V_{ref+} - V_{ref-}$ (see Note 2)		2.5	$V_{CC}$	$V_{CC} + 0.2$	V
Analog input voltage (see Note 2)		0			$V_{CC}$
High-level control input voltage, $V_{IH}$	$V_{CC} = 4.5$ V to 5.5 V	2			V
Low-level control input voltage, $V_{IL}$	$V_{CC} = 4.5$ V to 5.5 V	0.8			V
Clock frequency at I/O CLOCK (see Note 3)		0			2.1
Setup time, $\overline{CS}$ low before first I/O CLOCK↑, $t_{su}(CS)$ (see Note 4)		1.425			μs
Hold time, $\overline{CS}$ low after last I/O CLOCK↓, $t_h(CS)$		0			ns
Pulse duration, I/O CLOCK high, $t_{wH}(I/O)$		190			ns
Pulse duration, I/O CLOCK low, $t_{wL}(I/O)$		190			ns
Transition time, I/O CLOCK, $t_t(I/O)$ (see Note 5 and Figure 5)		1			μs
Transition time, $\overline{CS}$ , $t_t(CS)$		10			μs
Operating free-air temperature, $T_A$	TLC1549C	0			70
	TLC1549I	–40			85
	TLC1549M	–55			125

- NOTES:
2. Analog input voltages greater than that applied to REF+ convert as all ones (1111111111), while input voltages less than that applied to REF– convert as all zeros (0000000000). The TLC1549 is functional with reference voltages down to 1 V ( $V_{ref+} - V_{ref-}$ ); however, the electrical specifications are no longer applicable.
  3. For 11- to 16-bit transfers, after the tenth I/O CLOCK falling edge ( $\leq 2$  V) at least 1 I/O CLOCK rising edge ( $\geq 2$  V) must occur within 9.5 μs.
  4. To minimize errors caused by noise at  $\overline{CS}$ , the internal circuitry waits for a setup time plus two falling edges of the internal system clock after  $\overline{CS}$ ↓ before responding to the I/O CLOCK. No attempt should be made to clock out the data until the minimum  $\overline{CS}$  setup time has elapsed.
  5. This is the time required for the clock input signal to fall from  $V_{IHmin}$  to  $V_{ILmax}$  or to rise from  $V_{ILmax}$  to  $V_{IHmin}$ . In the vicinity of normal room temperature, the devices function with input clock transition time as slow as 1 μs for remote data-acquisition applications where the sensor and the A/D converter are placed several feet away from the controlling microprocessor.

# TLC1549C, TLC1549I, TLC1549M

## 10-BIT ANALOG-TO-DIGITAL CONVERTERS

### WITH SERIAL CONTROL

SLAS059C – DECEMBER 1992 – REVISED MARCH 1995

electrical characteristics over recommended operating free-air temperature range,  
 $V_{CC} = V_{ref+} = 4.5\text{ V to }5.5\text{ V}$ , I/O CLOCK frequency = 2.1 MHz (unless otherwise noted)

PARAMETER		TEST CONDITIONS	MIN	TYP†	MAX	UNIT	
V <sub>OH</sub>	High-level output voltage	V <sub>CC</sub> = 4.5 V, I <sub>OH</sub> = -1.6 mA	2.4			V	
		V <sub>CC</sub> = 4.5 V to 5.5 V, I <sub>OH</sub> = -20 μA	V <sub>CC</sub> - 0.1				
V <sub>OL</sub>	Low-level output voltage	V <sub>CC</sub> = 4.5 V, I <sub>OL</sub> = 1.6 mA			0.4	V	
		V <sub>CC</sub> = 4.5 V to 5.5 V, I <sub>OL</sub> = 20 μA			0.1		
I <sub>OZ</sub>	Off-state (high-impedance-state) output current	V <sub>O</sub> = V <sub>CC</sub> , $\overline{CS}$ at V <sub>CC</sub>			10	μA	
		V <sub>O</sub> = 0, $\overline{CS}$ at V <sub>CC</sub>			-10		
I <sub>IH</sub>	High-level input current	V <sub>I</sub> = V <sub>CC</sub>		0.005	2.5	μA	
I <sub>IL</sub>	Low-level input current	V <sub>I</sub> = 0		-0.005	-2.5	μA	
I <sub>CC</sub>	Operating supply current	$\overline{CS}$ at 0 V		0.8	2.5	mA	
Analog input leakage current		V <sub>I</sub> = V <sub>CC</sub>			1	μA	
		V <sub>I</sub> = 0			-1		
Maximum static analog reference current into REF+		V <sub>ref+</sub> = V <sub>CC</sub> , V <sub>ref-</sub> = GND			10	μA	
C <sub>i</sub>	Input capacitance	TLC1549C, I (Analog)	During sample cycle		30	55	pF
		TLC1549M (Analog)	During sample cycle		30		
		TLC1549C, I (Control)			5	15	
		TLC1549M (Control)			5		

† All typical values are at V<sub>CC</sub> = 5 V, T<sub>A</sub> = 25°C.



# TLC1549C, TLC1549I, TLC1549M

## 10-BIT ANALOG-TO-DIGITAL CONVERTERS WITH SERIAL CONTROL

SLAS059C – DECEMBER 1992 – REVISED MARCH 1995

**operating characteristics over recommended operating free-air temperature range,  
 $V_{CC} = V_{ref+} = 4.5\text{ V to }5.5\text{ V}$ , I/O CLOCK frequency = 2.1 MHz**

PARAMETER		TEST CONDITIONS	MIN	MAX	UNIT
$E_L$	Linearity error (see Note 6)			$\pm 1$	LSB
$E_{ZS}$	Zero-scale error (see Note 7)	See Note 2		$\pm 1$	LSB
$E_{FS}$	Full-scale error (see Note 7)	See Note 2		$\pm 1$	LSB
	Total unadjusted error (see Note 8)			$\pm 1$	LSB
$t_{conv}$	Conversion time	See Figures 6–10		21	$\mu\text{s}$
$t_c$	Total cycle time (access, sample, and conversion)	See Figures 6–10, See Note 9		21 + 10 I/O CLOCK periods	$\mu\text{s}$
$t_v$	Valid time, DATA OUT remains valid after I/O CLOCK $\downarrow$	See Figure 5	10		ns
$t_{d(I/O-DATA)}$	Delay time, I/O CLOCK $\downarrow$ to DATA OUT valid	See Figure 5		240	ns
$t_{PZH}, t_{PZL}$	Enable time, $\overline{CS}\downarrow$ to DATA OUT (MSB driven)	See Figure 3		1.3	$\mu\text{s}$
$t_{PHZ}, t_{PLZ}$	Disable time, $\overline{CS}\uparrow$ to DATA OUT (high impedance)	See Figure 3		180	ns
$t_{r(\text{bus})}$	Rise time, data bus	See Figure 5		300	ns
$t_{f(\text{bus})}$	Fall time, data bus	See Figure 5		300	ns
$t_{d(I/O-CS)}$	Delay time, tenth I/O CLOCK $\downarrow$ to $\overline{CS}\downarrow$ to abort conversion (see Note 10)			9	$\mu\text{s}$

- NOTES:
2. Analog input voltages greater than that applied to REF + convert as all ones (111111111), while input voltages less than that applied to REF – convert as all zeros (000000000). The TLC1549 is functional with reference voltages down to 1 V ( $V_{ref+} - V_{ref-}$ ); however, the electrical specifications are no longer applicable.
  6. Linearity error is the maximum deviation from the best straight line through the A/D transfer characteristics.
  7. Zero error is the difference between 000000000 and the converted output for zero input voltage; full-scale error is the difference between 111111111 and the converted output for full-scale input voltage.
  8. Total unadjusted error comprises linearity, zero, and full-scale errors.
  9. I/O CLOCK period = 1/(I/O CLOCK frequency). Sampling begins on the falling edge of the third I/O CLOCK, continues for seven I/O CLOCK periods, and ends on the falling edge of the 10th I/O CLOCK (see Figure 5).
  10. Any transitions of  $\overline{CS}$  are recognized as valid only if the level is maintained for a minimum of a setup time plus two falling edges of the internal clock (1.425  $\mu\text{s}$ ) after the transition.

TLC1549C, TLC1549I, TLC1549M  
 10-BIT ANALOG-TO-DIGITAL CONVERTERS  
 WITH SERIAL CONTROL

SLAS059C – DECEMBER 1992 – REVISED MARCH 1995

PARAMETER MEASUREMENT INFORMATION

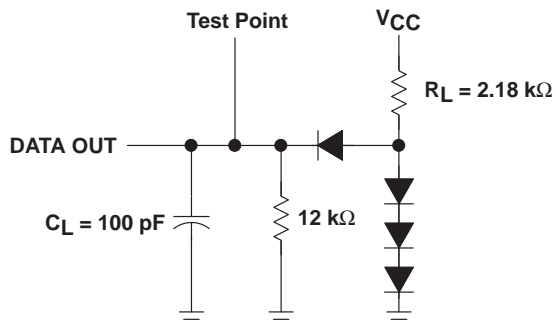

Figure 2. Load Circuit

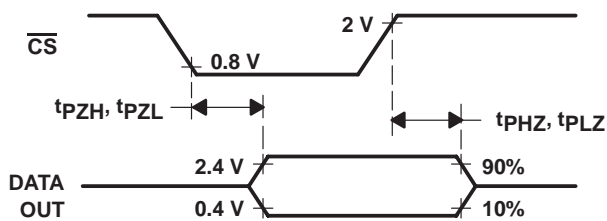

Figure 3. DATA OUT to Hi-Z Voltage Waveforms

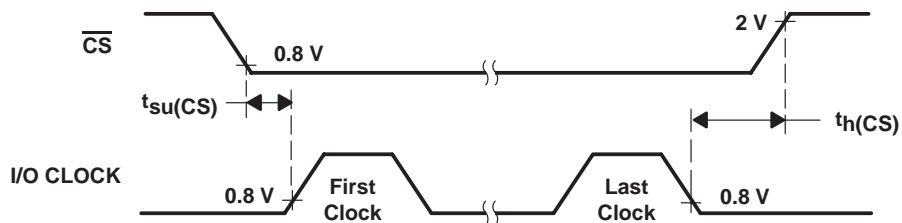

Figure 4. CS to I/O CLOCK Voltage Waveforms

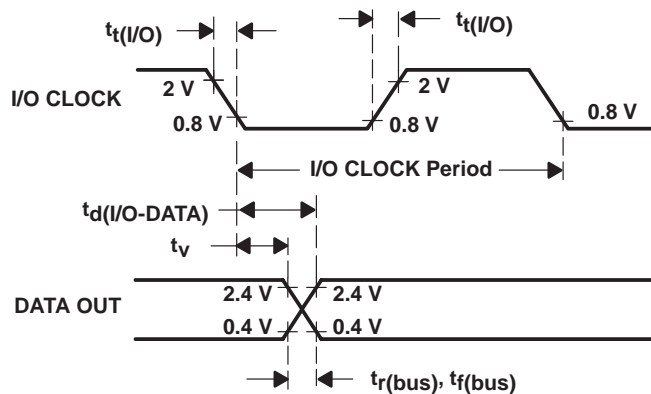

Figure 5. I/O CLOCK and DATA OUT Voltage Waveforms

# TLC1549C, TLC1549I, TLC1549M 10-BIT ANALOG-TO-DIGITAL CONVERTERS WITH SERIAL CONTROL

SLAS059C – DECEMBER 1992 – REVISED MARCH 1995

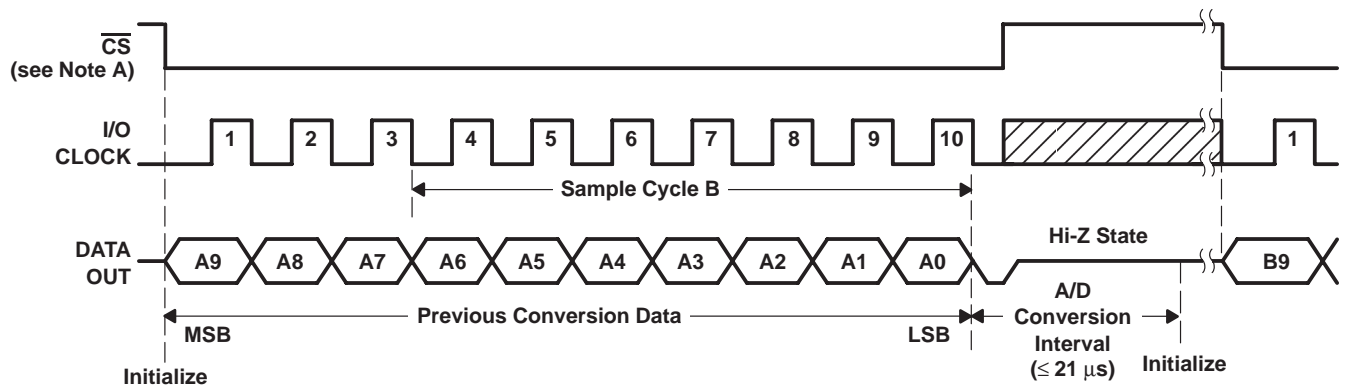

Figure 6. Timing for 10-Clock Transfer Using  $\overline{CS}$

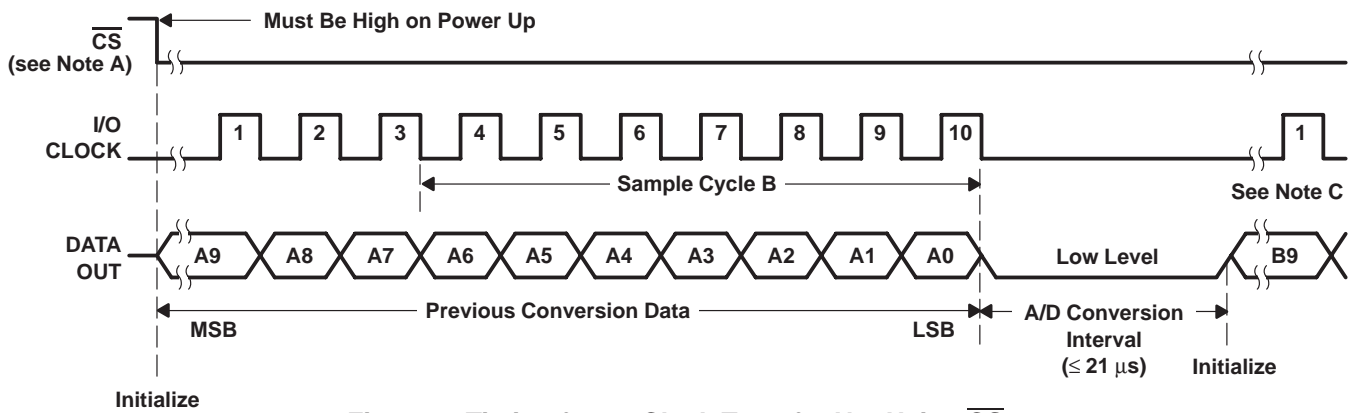

Figure 7. Timing for 10-Clock Transfer Not Using  $\overline{CS}$

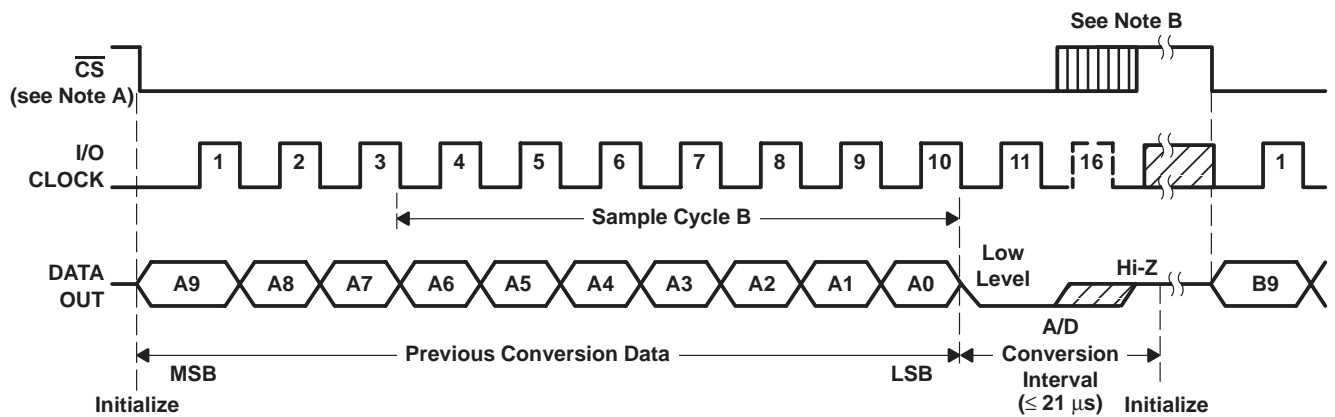

Figure 8. Timing for 11- to 16-Clock Transfer Using  $\overline{CS}$  (Serial Transfer Completed Within 21  $\mu$ s)

- NOTES:
- To minimize errors caused by noise at  $\overline{CS}$ , the internal circuitry waits for a setup time plus two falling edges of the internal system clock after  $\overline{CS} \downarrow$  before responding to the I/O CLOCK. No attempt should be made to clock out the data until the minimum  $\overline{CS}$  setup time has elapsed.
  - A low-to-high transition of  $\overline{CS}$  disables I/O CLOCK within a maximum of a setup time plus two falling edges of the internal system clock.
  - The first I/O CLOCK must occur after the end of the previous conversion.

# TLC1549C, TLC1549I, TLC1549M

## 10-BIT ANALOG-TO-DIGITAL CONVERTERS

### WITH SERIAL CONTROL

SLAS059C – DECEMBER 1992 – REVISED MARCH 1995

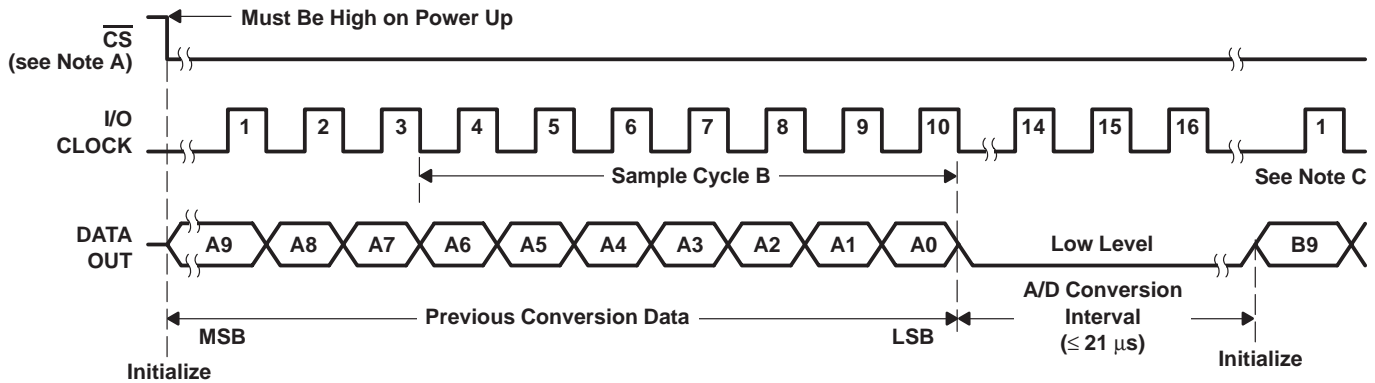

Figure 9. Timing for 16-Clock Transfer Not Using  $\overline{CS}$  (Serial Transfer Completed Within 21  $\mu s$ )

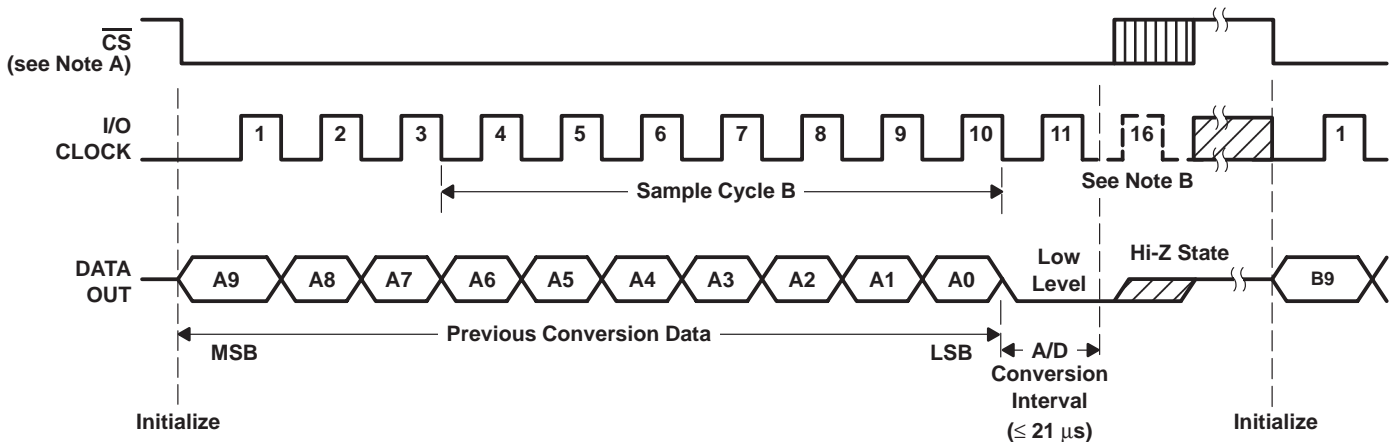

Figure 10. Timing for 11- to 16-Clock Transfer Using  $\overline{CS}$  (Serial Transfer Completed After 21  $\mu s$ )

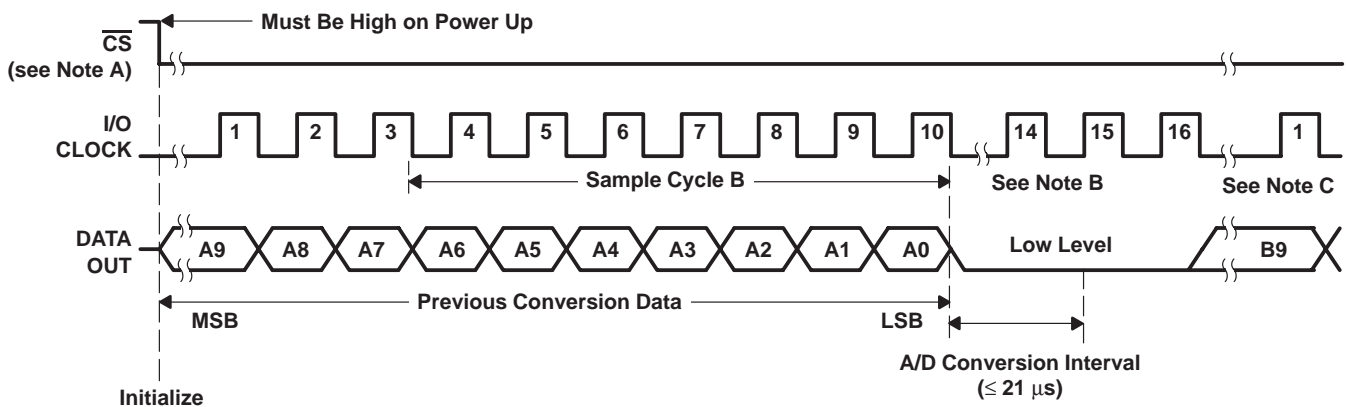

Figure 11. Timing for 16-Clock Transfer Not Using  $\overline{CS}$  (Serial Transfer Completed After 21  $\mu s$ )

- NOTES:
- A. To minimize errors caused by noise at  $\overline{CS}$ , the internal circuitry waits for a setup time plus two falling edges of the internal system clock after  $\overline{CS} \downarrow$  before responding to the I/O CLOCK. No attempt should be made to clock out the data until the minimum  $\overline{CS}$  setup time has elapsed.
  - B. A low-to-high transition of  $\overline{CS}$  disables I/O CLOCK within a maximum of a setup time plus two falling edges of the internal system clock.
  - C. The first I/O CLOCK must occur after the end of the previous conversion.

# TLC1549C, TLC1549I, TLC1549M 10-BIT ANALOG-TO-DIGITAL CONVERTERS WITH SERIAL CONTROL

SLAS059C – DECEMBER 1992 – REVISED MARCH 1995

## APPLICATION INFORMATION

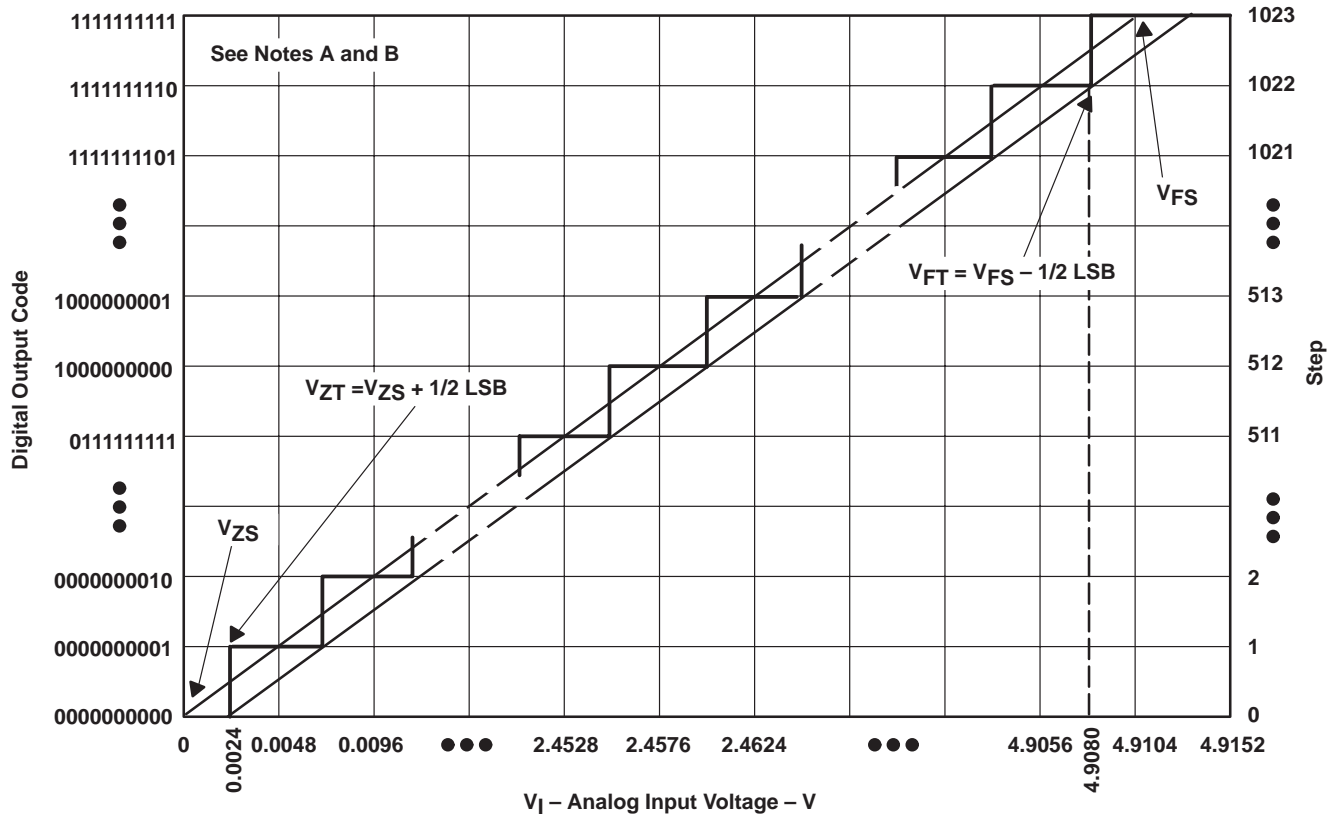

- NOTES: A. This curve is based on the assumption that  $V_{ref+}$  and  $V_{ref-}$  have been adjusted so that the voltage at the transition from digital 0 to 1 ( $V_{ZT}$ ) is 0.0024 V and the transition to full scale ( $V_{FT}$ ) is 4.908 V. 1 LSB = 4.8 mV.
- B. The full-scale value ( $V_{FS}$ ) is the step whose nominal midstep value has the highest absolute value. The zero-scale value ( $V_{ZS}$ ) is the step whose nominal midstep value equals zero.

Figure 12. Ideal Conversion Characteristics

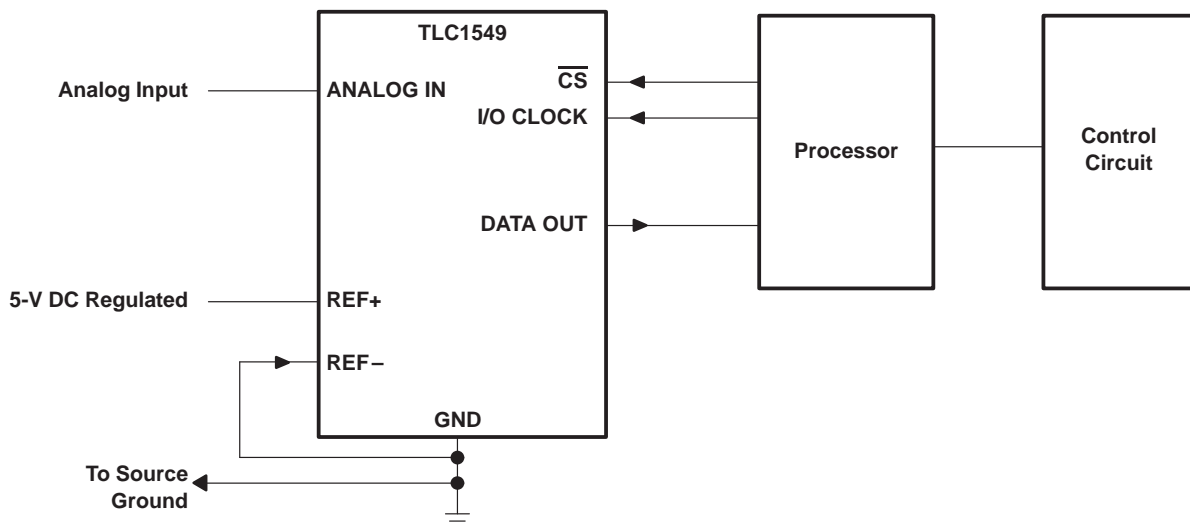

Figure 13. Typical Serial Interface

**TLC1549C, TLC1549I, TLC1549M**  
**10-BIT ANALOG-TO-DIGITAL CONVERTERS**  
**WITH SERIAL CONTROL**

SLAS059C – DECEMBER 1992 – REVISED MARCH 1995

**APPLICATION INFORMATION**

**simplified analog input analysis**

Using the equivalent circuit in Figure 14, the time required to charge the analog input capacitance from 0 V to  $V_S$  within 1/2 LSB can be derived as follows:

The capacitance charging voltage is given by

$$V_C = V_S \left( 1 - e^{-t_c / R_t C_i} \right) \tag{1}$$

where

$$R_t = R_s + r_i$$

The final voltage to 1/2 LSB is given by

$$V_C (1/2 \text{ LSB}) = V_S - (V_S / 2048) \tag{2}$$

Equating equation 1 to equation 2 and solving for time  $t_c$  gives

$$V_S - (V_S / 2048) = V_S \left( 1 - e^{-t_c / R_t C_i} \right) \tag{3}$$

and

$$t_c (1/2 \text{ LSB}) = R_t \times C_i \times \ln(2048) \tag{4}$$

Therefore, with the values given the time for the analog input signal to settle is

$$t_c (1/2 \text{ LSB}) = (R_s + 1 \text{ k}\Omega) \times 60 \text{ pF} \times \ln(2048) \tag{5}$$

This time must be less than the converter sample time shown in the timing diagrams.

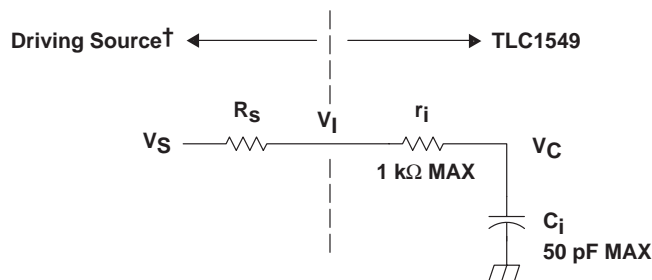

$V_I$  = Input Voltage at ANALOG IN  
 $V_S$  = External Driving Source Voltage  
 $R_S$  = Source Resistance  
 $r_i$  = Input Resistance  
 $C_i$  = Input Capacitance

† Driving source requirements:

- Noise and distortion for the source must be equivalent to the resolution of the converter.
- $R_S$  must be real at the input frequency.

**Figure 14. Equivalent Input Circuit Including the Driving Source**

## **IMPORTANT NOTICE**

Texas Instruments and its subsidiaries (TI) reserve the right to make changes to their products or to discontinue any product or service without notice, and advise customers to obtain the latest version of relevant information to verify, before placing orders, that information being relied on is current and complete. All products are sold subject to the terms and conditions of sale supplied at the time of order acknowledgement, including those pertaining to warranty, patent infringement, and limitation of liability.

TI warrants performance of its semiconductor products to the specifications applicable at the time of sale in accordance with TI's standard warranty. Testing and other quality control techniques are utilized to the extent TI deems necessary to support this warranty. Specific testing of all parameters of each device is not necessarily performed, except those mandated by government requirements.

CERTAIN APPLICATIONS USING SEMICONDUCTOR PRODUCTS MAY INVOLVE POTENTIAL RISKS OF DEATH, PERSONAL INJURY, OR SEVERE PROPERTY OR ENVIRONMENTAL DAMAGE ("CRITICAL APPLICATIONS"). TI SEMICONDUCTOR PRODUCTS ARE NOT DESIGNED, AUTHORIZED, OR WARRANTED TO BE SUITABLE FOR USE IN LIFE-SUPPORT DEVICES OR SYSTEMS OR OTHER CRITICAL APPLICATIONS. INCLUSION OF TI PRODUCTS IN SUCH APPLICATIONS IS UNDERSTOOD TO BE FULLY AT THE CUSTOMER'S RISK.

In order to minimize risks associated with the customer's applications, adequate design and operating safeguards must be provided by the customer to minimize inherent or procedural hazards.

TI assumes no liability for applications assistance or customer product design. TI does not warrant or represent that any license, either express or implied, is granted under any patent right, copyright, mask work right, or other intellectual property right of TI covering or relating to any combination, machine, or process in which such semiconductor products or services might be or are used. TI's publication of information regarding any third party's products or services does not constitute TI's approval, warranty or endorsement thereof.