

Converter IC for Capacitive Signals CAV414

FEATURES

- Wide Supply Voltage Range: 6...35V
- Wide Operating Temperature Range: -40°C...+85°C
- High Detection Sensitivity of Relative Capacitive Changes: 5% – 100%
- Detection Frequency up to 2kHz
- Adjustable Voltage Range: 0...5/10V, other
- Reference Voltage Source: 5V
- Protection against Reverse Polarity
- Output Current Limitation
- Adjustable with only two Resistors

APPLICATIONS

- Industrial Process Control
- Distance Measurement
- Pressure Measurement
- Humidity Measurement
- Level Control

GENERAL DESCRIPTION

The CAV414 is an universal multipurpose interface for capacitive sensors and contains the complete signal processing unit on chip. The CAV414 detects the relative capacitive change of a measuring capacity to a fixed reference capacity. The IC is optimised for capacities in the wide range of 10pF to 2nF with possible changes of capacity of 5% to 100% of the reference capacity.

The voltage output is formed by a high accuracy instrumentation amplifier in combination with an operational amplifier.

With only a few external components, the CAV414 is suitable for a great variety of applications including a zero compensation.

DELIVERY

- DIL16 packages (samples)
- SO16(n) packages
- Dice on 5" blue foil

BLOCK DIAGRAM

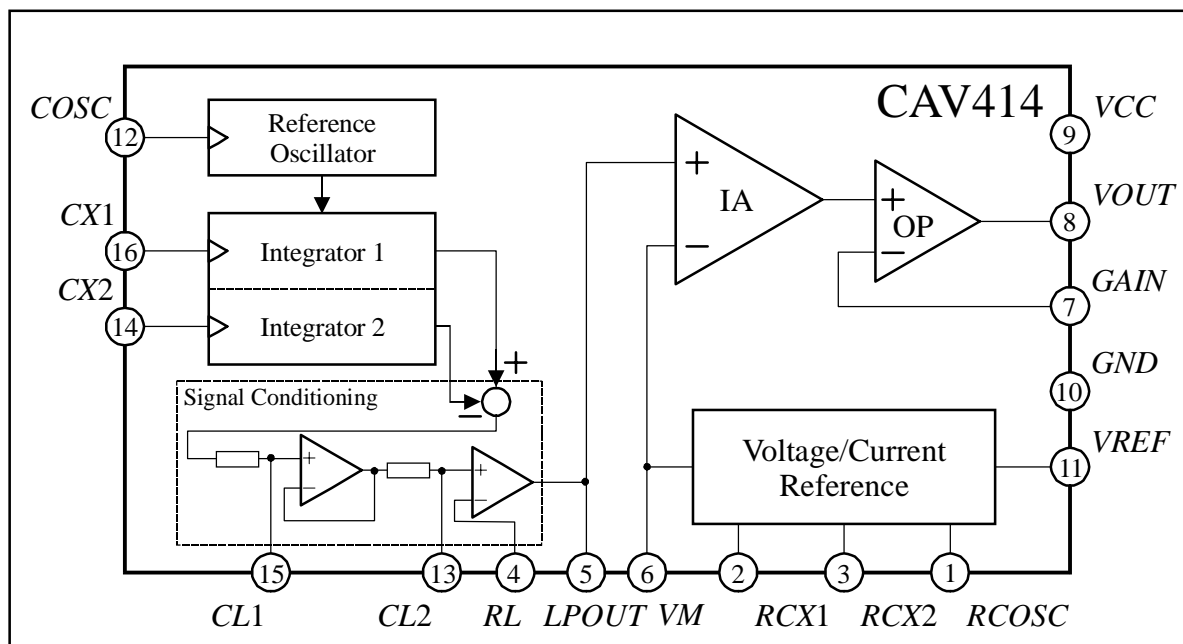

Figure 1

Converter IC for Capacitive Signals CAV414

ELECTRICAL SPECIFICATIONS

$T_{amb} = 25^{\circ}\text{C}$, $V_{CC} = 24\text{V}$, $I_{REF} = 1\text{mA}$ (unless otherwise noted)

Parameter	Symbol	Conditions	Min.	Typ.	Max.	Unit
Supply						
Supply Voltage	V_{CC}		6		35	V
Quiescent Current	I_{CC}	$T_{amb} = -40 \dots 85^{\circ}\text{C}$, $I_{REF} = 0\text{mA}$		1.55	2.7	mA
Temperature Specifications						
Operating	T_{amb}		-40		85	$^{\circ}\text{C}$
Storage	T_{st}		-55		125	$^{\circ}\text{C}$
Junction	T_j				150	$^{\circ}\text{C}$
Thermal Resistance	Θ_{ja}	DIL16 plastic package		70		$^{\circ}\text{C}/\text{W}$
	Θ_{ja}	SO16 (n) plastic package		140		$^{\circ}\text{C}/\text{W}$
Reference Oscillator						
Oscillator Capacitor Range	C_{OSC}	$C_{OSC} = 1.6 \cdot C_{X1}$	14		1800	pF
Oscillator Frequency Range	f_{OSC}		1		130	kHz
Oscillator Current	I_{OSC}	$R_{OSC} = 200\text{k}\Omega$	9.5	10	10.75	μA
Capacitive Integrator 1 and 2						
Capacitor Range 1	C_{X1}		10		1000	pF
Capacitive Integrator Current 1	I_{X1}	$R_{CX1} = 400\text{k}\Omega$	4.75	5	5.38	μA
Capacitor Detection Sensitivity	ΔC_X	$\Delta C_X = (C_{X2} - C_{X1})/C_{X1}$	5		100	%
Capacitor Range 2	C_{X2}	$C_{X2} = C_{X1} \cdot (1 + \Delta C_X)$	10.5		2000	pF
Capacitive Integrator Current 2	I_{X2}	$R_{CX2} = 400\text{k}\Omega$	4.75	5	5.38	μA
Detection Frequency	f_{DET}	$C_{L1} = C_{L2} = 1\text{nF}$			2	kHz
Lowpass						
Adjustable Gain	G_{LP}		1		10	
Output Voltage	V_{LPOUT}		$V_M - 0.4$		$V_M + 0.4$	V
Corner Frequency 1	f_{C1}	$R_{01} = 20\text{k}\Omega$, $C_{L1} = 1\text{nF}$			10	kHz
Corner Frequency 2	f_{C2}	$R_{02} = 20\text{k}\Omega$, $C_{L2} = 1\text{nF}$			10	kHz
Resistive Load at PIN $LPOUT$	R_{LOAD}		200			k Ω
Capacitive Load at PIN $LPOUT$	C_{LOAD}				50	pF
Temperature Coefficient V_{DIFF} (together with Input Stages)	dV_{DIFF}/dT	$V_{DIFF} = V_{LPOUT} - V_M$, $T_{amb} = -40 \dots 85^{\circ}\text{C}$		± 100		ppm/ $^{\circ}\text{C}$
Internal Resistor 1 and 2	R_{01} , R_{02}			20		k Ω
Temperature Coefficient $R_{01,02}$	$dR_{01,02}/dT$	$T_{amb} = -40 \dots 85^{\circ}\text{C}$		1.9		$10^{-3}/^{\circ}\text{C}$
Power Supply Rejection Ratio (together with Input Stages)	$PSRR$	$I_{OUT} \leq 1\text{mA}$	80	90		dB
Voltage Reference V_{REF}						
Voltage	V_{REF}		4.75	5	5.25	V
Current	I_{REF}		0		9	mA
V_{REF} vs. Temperature	dV_{REF}/dT	$T_{amb} = -40 \dots +85^{\circ}\text{C}$		± 90	± 140	ppm/ $^{\circ}\text{C}$
Line Regulation	dV_{REF}/dV	$V_{CC} = 6\text{V} \dots 35\text{V}$		30	80	ppm/V
	dV_{REF}/dV	$V_{CC} = 6\text{V} \dots 35\text{V}$, $I_{REF} \approx 4\text{mA}$		60	150	ppm/V
Load Regulation	dV_{REF}/dI			0.05	0.10	%/mA
	dV_{REF}/dI	$I_{REF} \approx 4\text{mA}$		0.06	0.15	%/mA
Load Capacitance	C_{REF}		1.9	2.2	5.0	μF

Converter IC for Capacitive Signals CAV414

Parameter	Symbol	Conditions	Min.	Typ.	Max.	Unit
Voltage Reference V_M						
Voltage	V_M		1.90	2	2.15	V
V_M vs. Temperature	dV_M/dT	$T_{amb} = -40...+85^\circ\text{C}$		± 90		ppm/ $^\circ\text{C}$
Current	I_{VM}	Source			5	μA
	I_{VM}	Sink			-5	μA
Load Capacitance	C_{VM}		80	100	120	nF
Instrumentation Amplifier Input Stage						
Internal Gain	G_{IA}		4.9	5	5.1	
Differential Range	V_{IN}		0		400	mV
Common Mode Input Range	$CMIR$	$V_{CC} < 9\text{V}, I_{CV} < 2\text{mA}$	1.5		$V_{CC} - 3$	V
	$CMIR$	$V_{CC} \geq 9\text{V}, I_{CV} < 2\text{mA}$	1.5		6.0	V
Common Mode Rejection Ratio	$CMRR$		80	90		dB
Power Supply Rejection Ratio	$PSRR$	$I_{OUT} \leq 1\text{mA}$	80	90		dB
Offset Voltage	V_{OS}			± 1.5	± 6	mV
V_{OS} vs. Temperature	dV_{OS}/dT			± 5		$\mu\text{V}/^\circ\text{C}$
Output Stage						
Adjustable Gain	G_{OP}		1			
Input Range	IR	$V_{CC} < 11\text{V}$	0		$V_{CC} - 5$	V
	IR	$V_{CC} \geq 11\text{V}$	0		6	V
Power Supply Rejection Ratio	$PSRR$	$I_{OUT} \leq 1\text{mA}$	80	90		dB
Offset Voltage	V_{OS}			± 0.5	± 2	mV
V_{OS} vs. Temperature	dV_{OS}/dT			± 3	± 7	$\mu\text{V}/^\circ\text{C}$
Input Bias Current	I_B			10	25	nA
I_B vs. Temperature	dI_B/dT			7	20	pA/ $^\circ\text{C}$
Output Voltage Range	V_{OUT}	$V_{CC} < 19\text{V}$	0		$V_{CC} - 5$	V
	V_{OUT}	$V_{CC} \geq 19\text{V}$	0		14	V
Output Current Limitation	I_{LIM}	$V_{CC} \geq 10\text{V}$	5	7	10	mA
Output Current	I_{OUT}		0		I_{LIM}	mA
Load Resistance	R_L		2			k Ω
Load Capacitance	C_L				500	nF
Protection Functions						
Protection Against Reverse Polarity		Ground vs. V_{CC} vs. V_{OUT}			35	V

Note:

- 1) The oscillator capacity has to be chosen in the following way: $C_{OSC} = 1.6 \cdot C_{X1}$
- 2) The capacitor range of C_{X1} and C_{X2} can be extended whereby the system performance is reduced and the electrical limits are exceeded.
- 3) Currents flowing into the IC, are negative.

BOUNDARY CONDITIONS

Parameter	Symbol	Min.	Typ.	Max.	Unit
Current Definition of Ref. Oscillator	R_{OSC}	190	200	210	$k\Omega$
Current Adjustment of Cap. Integrator 1	R_{CX1}	350	400	450	$k\Omega$
Current Adjustment of Cap. Integrator 2	R_{CX2}	350	400	450	$k\Omega$
Lowpass Stage Resistor Sum	$R_{L1} + R_{L2}$	90		200	$k\Omega$
Output Stage Resistor Sum	$R_1 + R_2$	90		200	$k\Omega$
Reference Voltage 5V	C_{REF}	1.9	2.2	5	μF
Reference Voltage 2V (only for internal use)	C_{VM}	80	100	120	nF
Lowpass Capacitance 1	C_{L1}	$100 \cdot C_{X1}$	$200 \cdot C_{X1}$		
Lowpass Capacitance 2	C_{L2}	$100 \cdot C_{X1}$	$200 \cdot C_{X1}$		
Oscillator Capacitance	C_{OSC}	$C_{OSC} = 1.55 \cdot C_{X1}$	$C_{OSC} = 1.60 \cdot C_{X1}$	$C_{OSC} = 1.65 \cdot C_{X1}$	

Note: The system performance over temperature forces that the resistors R_{CX1} , R_{CX2} and R_{OSC} have the same temperature coefficient and a very close placement of them in the circuit. The capacities C_{X1} , C_{X2} and C_{OSC} are also forced to have the same temperature coefficient and a very close placement of them in the circuit.

FUNCTIONAL DIAGRAM

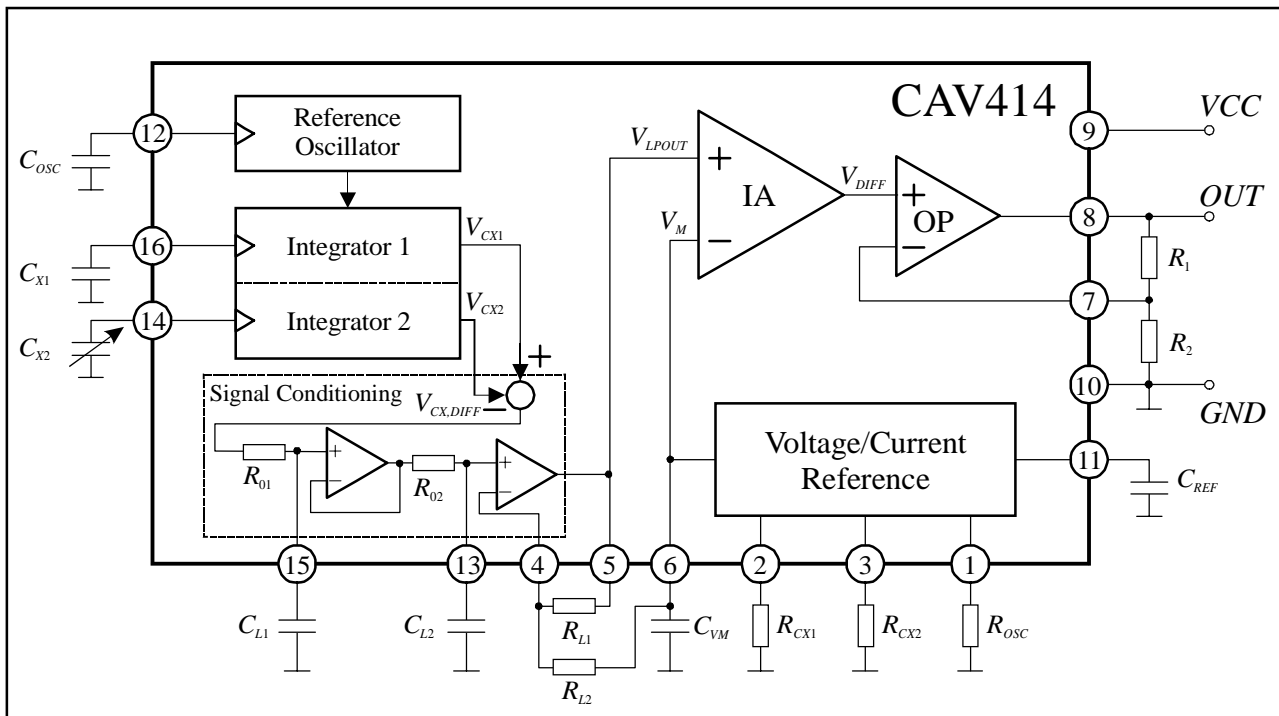

Figure 2

FUNCTIONAL DESCRIPTION

A reference oscillator with a frequency adjusted by the capacity C_{OSC} drives two symmetrically built integrators synchronously to its clock and its phase. The capacitors C_{X1} and C_{X2} determine the amplitude of the two driven integrators. The difference of the integrator amplitudes gives the relative change of the capacities C_{X1} and C_{X2} to each other with high common mode rejection and high resolution. The difference signal is conditioned by a lowpass filter. The corner frequency and gain of it can be adjusted with a few external components. The output of the lowpass filter is connected to an instrumentation amplifier and an output stage. These two stages transform the signal into an adjustable voltage.

Adjustment:

The zero-adjustment is made by the resistors R_{CX1} or R_{CX2} for the case that the varying capacitance C_{X2} has nearly the same (and its smallest) value as the fixed capacitance C_{X1} (reference capacitance). Therefore one of this resistors is varied until the differential voltage

$$V_{DIFF} = V_{LPOUT} - V_M$$

is zero:

$$V_{DIFF} = 0$$

Application Example:

The following values are given:

- fixed capacitance C_{X1} : 50pF
- varying capacitance C_{X2} : 50 ... 100pF

Calculation:

With the equations given in the boundary conditions, the following values for the devices can be calculated:

- C_{OSC} : 80pF
- C_{L1} : 10nF
- C_{L2} : 10nF

If the signal V_{DIFF} is amplified, it has to fulfil the unequation:

$$V_{DIFF} \leq 400\text{mV}$$

Detailed calculations are shown in a separately available *Application Note*.

PINOUT

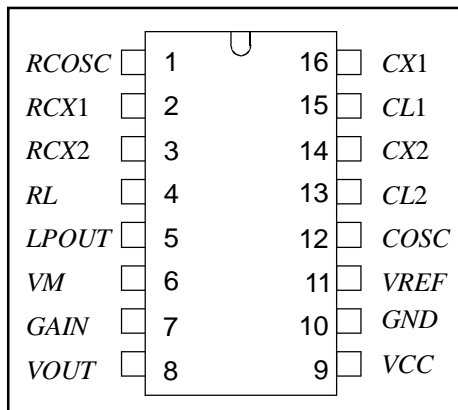

Figure 3

PIN	NAME	DESIGNATION
1	RCOSC	Current Definition of Ref. Oscillator
2	RCX1	Current Adjustment of Cap. Integrator 1
3	RCX2	Current Adjustment of Cap. Integrator 2
4	RL	Gain Adjustment of Lowpass Filter
5	LPOUT	Output of Lowpass Filter
6	VM	Reference Voltage 2V
7	GAIN	Gain Adjustment
8	VOUT	Voltage Output
9	VCC	Supply Voltage
10	GND	IC Ground
11	VREF	Reference Voltage 5V
12	COSC	Capacitor of Reference Oscillator
13	CL2	Corner Frequency of Lowpass 2
14	CX2	Integrator Capacitor 2
15	CL1	Corner Frequency of Lowpass 1
16	CX1	Integrator Capacitor 1

DELIVERY

The CAV414 is available in version:

- 16-Pin-DIL (samples)
- SO 16 (n) (Maximum Power Dissipation $P_D = 300\text{mW}$)
- Dice on 5" blue foil

PACKAGE DIMENSIONS SO16 (n)

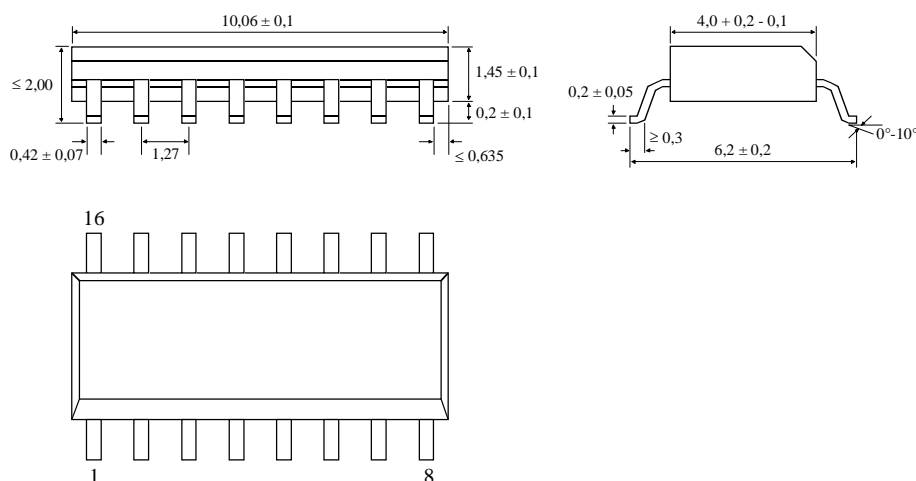

Figure 4

The information provided herein is believed to be reliable; however, Analog Microelectronics assumes no responsibility for inaccuracies or omissions. Analog Microelectronics assumes no responsibility for the use of this information, and all use of such information shall be entirely at the user's own risk. Prices and specifications are subject to change without notice. No patent rights or licences to any of the circuits described herein are implied or granted to any third party. Analog Microelectronics does not authorise or warrant any Analog Microelectronics product use in life support devices and/or systems.