



IMP809, IMP810

POWER MANAGEMENT

3-Pin Microcontroller Power Supply Supervisor

The IMP809/IMP810 are 3.0V, 3.3V and 5.0V power supply supervisor circuits optimized for low-power microprocessor (μP), microcontroller (μC) and digital systems. The IMP809/810 are improved drop-in replacements for the Maxim MAX809/810 and feature 60% lower supply current.

A reset signal is issued if the power supply voltage drops below a preset reset threshold and is asserted for at least 140ms after the supply has risen above the reset threshold. The IMP809 has an active-low \overline{RESET} output that is guaranteed to be in the correct state for V_{CC} down to 1.1V. The IMP810 has an active-high $RESET$ output. The reset comparator is designed to ignore fast transients on V_{CC} .

Low supply current makes the IMP809/IMP810 ideal for use in portable and battery operated equipment. The IMP809/IMP810 are available in a compact 3-pin SOT23 package.

Six voltage thresholds are available to support 3V to 5V systems:

Reset Threshold	
Suffix	Voltage (V)
L	4.63
M	4.38
J	4.00
T	3.08
S	2.93
R	2.63

Block Diagrams

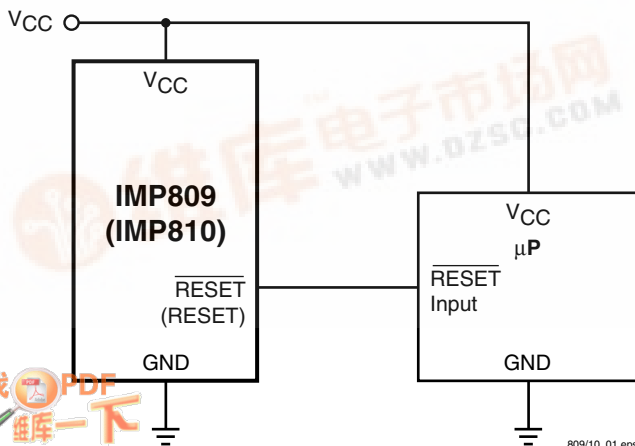

Key Features

- ◆ Improved Maxim MAX809/MAX810 replacement
 - Lower supply current...6 μA
 - 80% lower maximum supply current
- ◆ Monitor 5V, 3.3V and 3V supplies
- ◆ 140ms min. reset pulse width
- ◆ Active-low reset valid with 1.1V supply (IMP809)
- ◆ Small 3-pin SOT-23 package
- ◆ No external components
- ◆ Specified over full temperature range
 - -40°C to 105°C

Applications

- ◆ Embedded controllers
- ◆ Battery operated systems
- ◆ Intelligent instruments
- ◆ Wireless communication systems
- ◆ PDAs and handheld equipment



Pin Configuration

SOT23

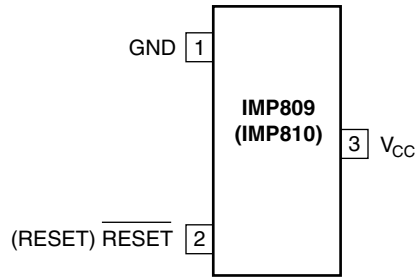

809/10_02.eps

Ordering Information

Part Number ¹	Reset Threshold (V)	Temperature Range	Pin-Package	Package Marking ² (XX Lot Code)
IMP809 Active LOW Reset				
IMP809LEUR-T	4.63	-40°C to +105°C	3-SOT23	AAXX
IMP809MEUR-T	4.38	-40°C to +105°C	3-SOT23	ABXX
IMP809JEUR-T	4.00	-40°C to +105°C	3-SOT23	CWXX
IMP809TEUR-T	3.08	-40°C to +105°C	3-SOT23	ACXX
IMP809SEUR-T	2.93	-40°C to +105°C	3-SOT23	ADXX
IMP809REUR-T	2.63	-40°C to +105°C	3-SOT23	AFXX
IMP810 Active HIGH Reset				
IMP810LEUR-T	4.63	-40°C to +105°C	3-SOT23	AGXX
IMP810MEUR-T	4.38	-40°C to +105°C	3-SOT23	AHXX
IMP810JEUR-T	4.00	-40°C to +105°C	3-SOT23	AIXX
IMP810TEUR-T	3.08	-40°C to +105°C	3-SOT23	AJXX
IMP810SEUR-T	2.93	-40°C to +105°C	3-SOT23	AKXX
IMP810REUR-T	2.63	-40°C to +105°C	3-SOT23	ALXX

Notes: 1. Tape and Reel packaging is indicated by the -T designation.
 2. Devices may also be marked with full part number: 809L, 810M etc. XX refers to lot.

Related Products

	IMP809	IMP810	IMP811	IMP812
Max. Supply Current	15µA	15µA	15µA	15µA
Package Pins	3	3	4	4
Manual RESET input			■	■
Package Type	SOT-23	SOT-23	SOT-143	SOT-143
Active-HIGH RESET output		■		■
Active-LOW RESET output	■		■	

Absolute Maximum Ratings

Pin Terminal Voltage with Respect to Ground

V_{CC}	-0.3V to 6.0V
RESET, $\overline{\text{RESET}}$	-0.3V to ($V_{CC} + 0.3V$)
Input Current at V_{CC}	20mA
Output Current: RESET, $\overline{\text{RESET}}$	20mA
Rate of Rise at V_{CC}	100V/ μ s

Power Dissipation ($T_A = 70^\circ\text{C}$)	320mW
(Derate 4mW/ $^\circ\text{C}$ above 70 $^\circ\text{C}$)	
Operating Temperature Range	-40 $^\circ\text{C}$ to 105 $^\circ\text{C}$
Storage Temperature Range	-65 $^\circ\text{C}$ to 160 $^\circ\text{C}$
Lead Temperature (soldering, 10 sec)	300 $^\circ\text{C}$

These are stress ratings only and functional operation is not implied. Exposure to absolute maximum ratings for prolonged time periods may affect device reliability

Electrical Characteristics

Unless otherwise noted V_{CC} is over the full voltage range, $T_A = -40^\circ\text{C}$ to 105 $^\circ\text{C}$.

Typical values at $T_A = 25^\circ\text{C}$, $V_{CC} = 5V$ for L/M/J devices, $V_{CC} = 3.3V$ for T/S devices and $V_{CC} = 3V$ for R devices.

Parameter	Symbol	Conditions	Min	Typ	Max	Units	
Input Voltage (V_{CC}) Range	V_{CC}	$T_A = 0^\circ\text{C}$ to 70 $^\circ\text{C}$ $T_A = -40^\circ\text{C}$ to 105 $^\circ\text{C}$	1.1 1.2		5.5 5.5	V	
Supply Current	I_{CC}	$T_A = -40^\circ\text{C}$ to 85 $^\circ\text{C}$ $T_A = -40^\circ\text{C}$ to 85 $^\circ\text{C}$ $T_A = 85^\circ\text{C}$ to 105 $^\circ\text{C}$ $T_A = 85^\circ\text{C}$ to 105 $^\circ\text{C}$		9 6	15 10 25 20	μA	
Reset Threshold	V_{TH}	L devices	$T_A = 25^\circ\text{C}$ $T_A = -40^\circ\text{C}$ to 85 $^\circ\text{C}$ $T_A = 85^\circ\text{C}$ to 105 $^\circ\text{C}$	4.56 4.50 4.40	4.63	4.70 4.75 4.86	V
		M devices	$T_A = 25^\circ\text{C}$ $T_A = -40^\circ\text{C}$ to 85 $^\circ\text{C}$ $T_A = 85^\circ\text{C}$ to 105 $^\circ\text{C}$	4.31 4.25 4.16	4.38	4.45 4.50 4.56	
		J devices	$T_A = 25^\circ\text{C}$ $T_A = -40^\circ\text{C}$ to 85 $^\circ\text{C}$ $T_A = 85^\circ\text{C}$ to 105 $^\circ\text{C}$	3.93 3.89 3.80	4.00	4.06 4.10 4.20	
		T devices	$T_A = 25^\circ\text{C}$ $T_A = -40^\circ\text{C}$ to 85 $^\circ\text{C}$ $T_A = 85^\circ\text{C}$ to 105 $^\circ\text{C}$	3.04 3.00 2.92	3.08	3.11 3.15 3.23	
		S devices	$T_A = 25^\circ\text{C}$ $T_A = -40^\circ\text{C}$ to 85 $^\circ\text{C}$ $T_A = 85^\circ\text{C}$ to 105 $^\circ\text{C}$	2.89 2.85 2.78	2.93	2.96 3.00 3.08	
		R devices	$T_A = 25^\circ\text{C}$ $T_A = -40^\circ\text{C}$ to 85 $^\circ\text{C}$ $T_A = 85^\circ\text{C}$ to 105 $^\circ\text{C}$	2.59 2.55 2.50	2.63	2.66 2.70 2.76	
Reset Threshold Stability				30		ppm/ $^\circ\text{C}$	
V_{CC} to Reset Delay		$V_{CC} = V_{TH}$ to $V_{TH} - 100\text{mV}$		20		μs	
Reset Active Timeout Period		$T_A = -40^\circ\text{C}$ to 85 $^\circ\text{C}$	140	240	560	ms	
		$T_A = 85^\circ\text{C}$ to 105 $^\circ\text{C}$	100		840		
Low RESET Output Voltage (IMP809)	V_{OL}	$V_{CC} = V_{TH}$ min., $I_{SINK} = 1.2\text{mA}$, IMP809R/S/T			0.3	V	
		$V_{CC} = V_{TH}$ min., $I_{SINK} = 3.2\text{mA}$, IMP809L/M/J			0.4		
		$V_{CC} > 1.1V$, $I_{SINK} = 50\mu\text{A}$			0.3		
High RESET Output Voltage (IMP809)	V_{OH}	$V_{CC} > V_{TH}$ max., $I_{SOURCE} = 500\mu\text{A}$, IMP809R/S/T	0.8 V_{CC}			V	
		$V_{CC} > V_{TH}$ max., $I_{SOURCE} = 800\mu\text{A}$, IMP809L/M/J	$V_{CC} - 1.5$				
Low RESET Output Voltage (IMP810)	V_{OL}	$V_{CC} = V_{TH}$ max., $I_{SINK} = 1.2\text{mA}$, IMP810R/S/T			0.3	V	
		$V_{CC} = V_{TH}$ max., $I_{SINK} = 3.2\text{mA}$, IMP810L/M/J			0.4		
High RESET Output Voltage (IMP810)	V_{OH}	$1.8V < V_{CC} < V_{TH}$ min., $I_{SOURCE} = 150\mu\text{A}$	0.8 V_{CC}			V	

Notes: 1. Production testing done at $T_A = 25^\circ\text{C}$. Over-temperature specifications guaranteed by design only.
2. RESET output is active LOW for the IMP809 and RESET output is active HIGH for the IMP810

Pin Descriptions

Pin Number	Name	Function
1	GND	Ground
2 (IMP809)	$\overline{\text{RESET}}$	$\overline{\text{RESET}}$ is asserted LOW if V_{CC} falls below the reset threshold and remains LOW for the 240ms typical reset timeout period (140ms minimum) after V_{CC} exceeds the threshold.
2 (IMP810)	RESET	RESET is asserted HIGH if V_{CC} falls below the reset threshold and remains HIGH for the 240ms typical reset timeout period (140ms minimum) after V_{CC} exceeds the threshold.
3	V_{CC}	Power supply input voltage (3.0V, 3.3V, 5.0V)

Detailed Descriptions

Reset Timing

The reset signal is asserted LOW for the IMP809 and HIGH for the IMP810—when the V_{CC} signal falls below the threshold trip voltage and remains asserted for 140ms minimum after the V_{CC} has risen above the threshold.

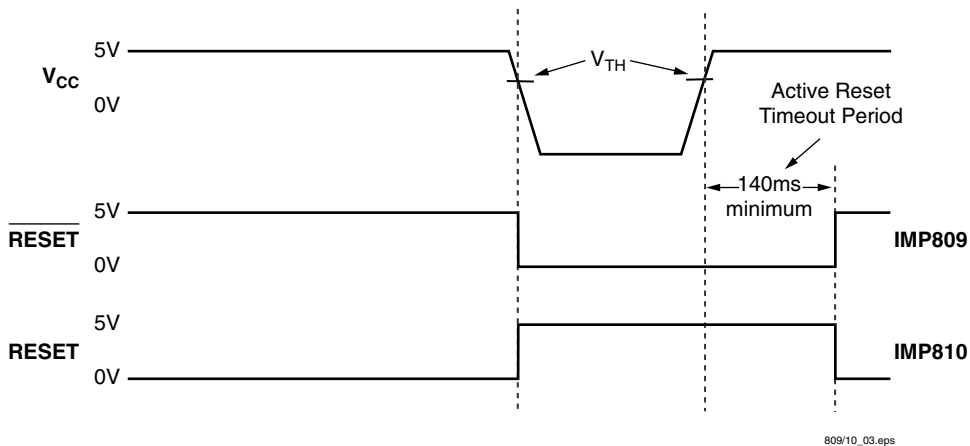

Figure 1. Reset Timing Diagram

Application Information

Negative V_{CC} Transients

The IMP809/810 protect μ Ps from brownouts and low V_{CC}. Short duration transients of 100mV amplitude and 20 μ s or less duration typically do not cause a false RESET.

Valid Reset with V_{CC} under 1.1V

To ensure logic inputs connected to the IMP809 $\overline{\text{RESET}}$ pin are in a known state when V_{CC} is under 1.1V, a 100k Ω pull-down

resistor at $\overline{\text{RESET}}$ is needed. The value is not critical. A pull-up resistor to V_{CC} is needed with the IMP810.

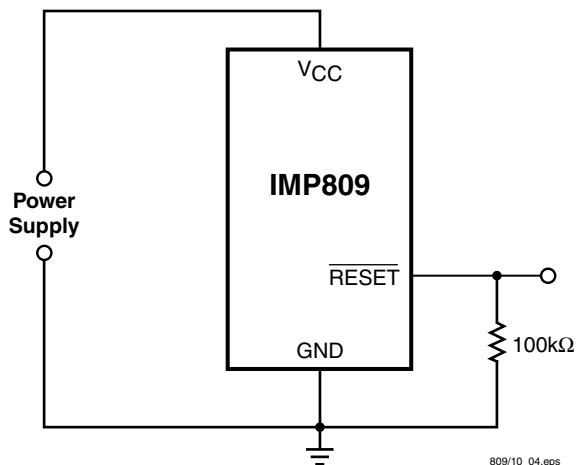

Figure 2. $\overline{\text{RESET}}$ Valid with V_{CC} Under 1.1V

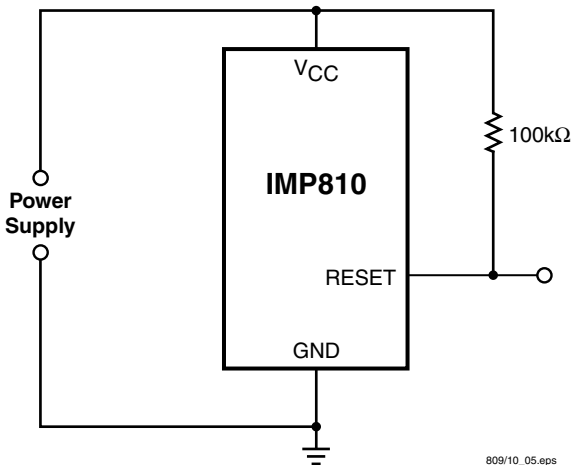

Figure 3. RESET Valid with V_{CC} Under 1.1V

Bi-directional Reset Pin Interfacing

The IMP809/810 can interface with μ P/ μ C bi-directional reset pins by connecting a 4.7k Ω resistor in series with the IMP809/810 reset output and the μ P/ μ C bi-directional reset pin.

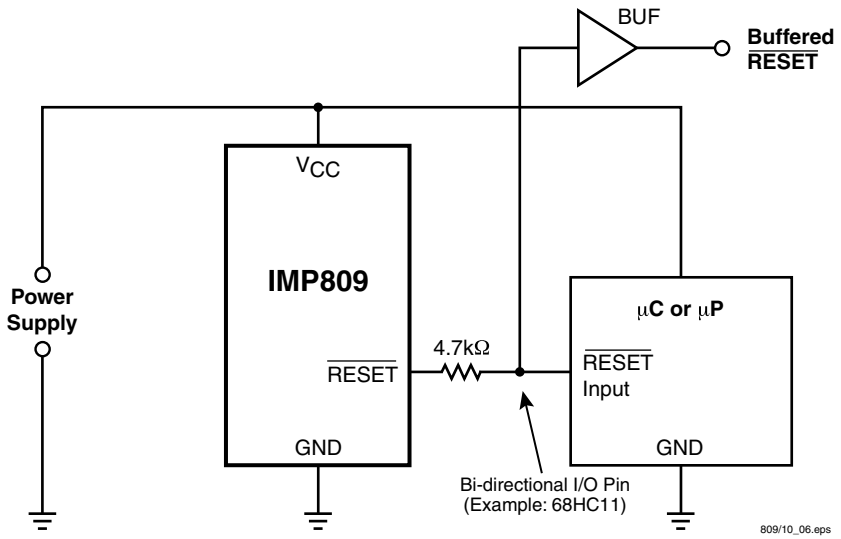
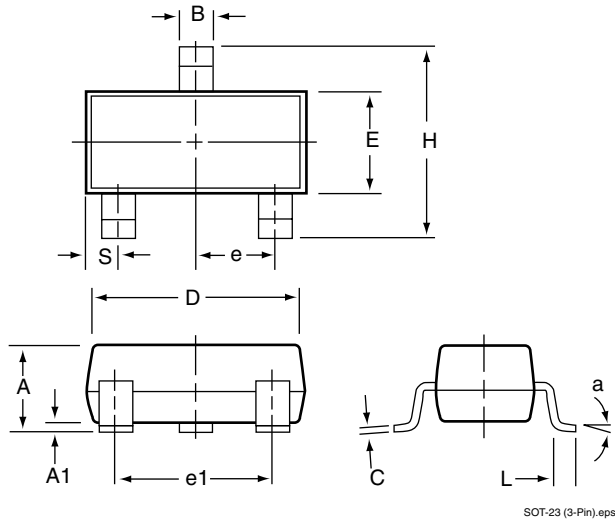

Figure 4. Bi-directional Reset Pin Interfacing

Package Dimensions

Plastic SOT-23 (3-Pin)



	Inches		Millimeters	
	Min	Max	Min	Max
Plastic SOT-23 (3-Pin)				
A	0.031	0.050	0.80	1.27
A1	0.004	0.010	0.10	0.25
B	0.015	0.020	0.37	0.51
C	0.003	0.007	0.085	0.18
D	0.110	0.120	2.80	3.04
E	0.047	0.055	1.20	1.40
e	0.035	0.040	0.89	1.03
e1	0.070	0.080	1.78	2.05
H	0.083	0.1039	2.10	2.64
L	0.027 REF		0.069 REF	
S	0.018	0.024	0.45	0.60

SOT-23 (3-Pin).eps



IMP, Inc.
Corporate Headquarters
2830 N. First Street
San Jose, CA 95134-2071
Tel: 408-432-9100
Tel: 800-438-3722
Fax: 408-434-0335
e-mail: info@impinc.com
<http://www.impweb.com>