

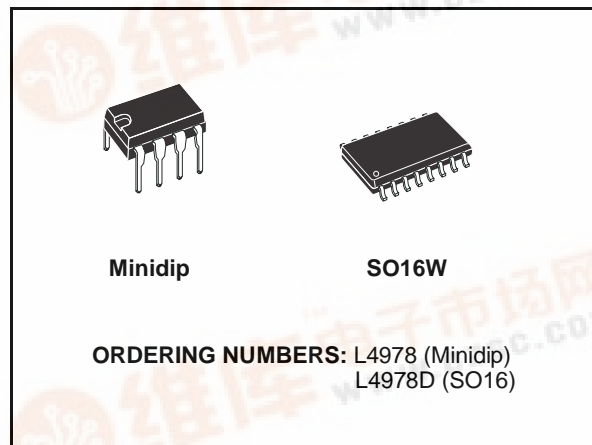

L4978

2A STEP DOWN SWITCHING REGULATOR

- UP TO 2A STEP DOWN CONVERTER
- OPERATING INPUT VOLTAGE FROM 8V TO 55V
- PRECISE 3.3V ($\pm 1\%$) INTERNAL REFERENCE VOLTAGE
- OUTPUT VOLTAGE ADJUSTABLE FROM 3.3V TO 50V
- SWITCHING FREQUENCY ADJUSTABLE UP TO 500KHz
- VOLTAGE FEEDFORWARD
- ZERO LOAD CURRENT OPERATION
- INTERNAL CURRENT LIMITING (PULSE-BY-PULSE AND HICCUP MODE)
- INHIBIT FOR ZERO CURRENT CONSUMPTION
- PROTECTION AGAINST FEEDBACK DISCONNECTION
- THERMAL SHUTDOWN
- SOFT START FUNCTION



DESCRIPTION

The L4978 is a step down monolithic power switching regulator delivering 2A at a voltage between 3.3V and 50V (selected by a simple external divider). Realized in BCD mixed technology, the device uses an internal power D-MOS transistor (with a typical R_{dson} of 0.25Ω) to obtain very high efficiency and high switching speed.

A switching frequency up to 500KHz is achievable (the maximum power dissipation of the packages must be observed). A wide input voltage range between 8V to 55V and output voltages regulated from 3.3V to 50V cover the majority of today's applications. Features of this new generations of DC-DC converter include pulse-by-pulse current limit, hiccup mode for short circuit protection, voltage feedforward regulation, soft-start, protection against feedback loop disconnection, inhibit for zero current consumption and thermal shutdown.

The device is available in plastic dual in line, MINIDIP 8 for standard assembly, and SO16W for SMD assembly.

TYPICAL APPLICATION CIRCUIT

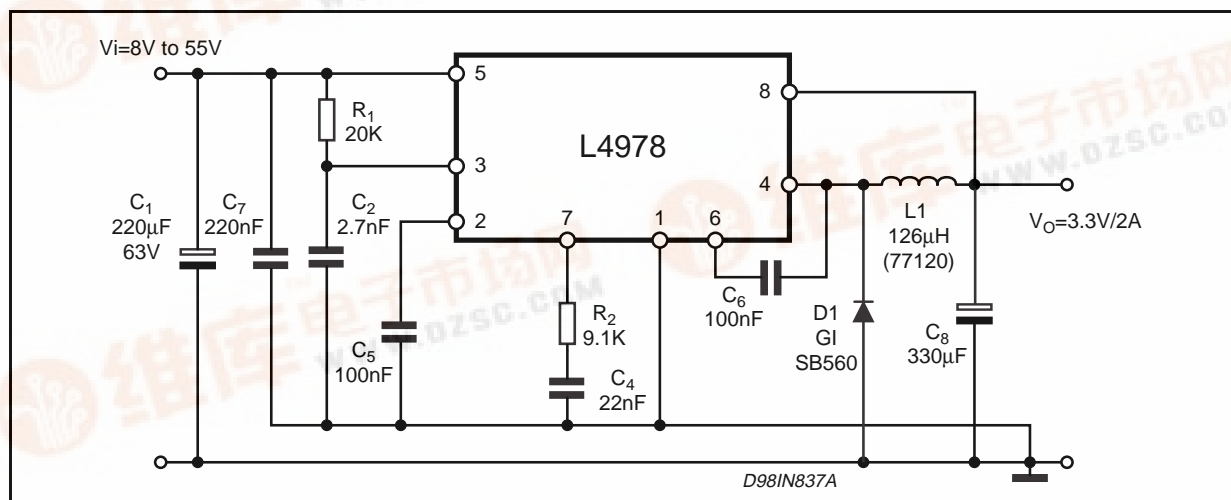

BLOCK DIAGRAM

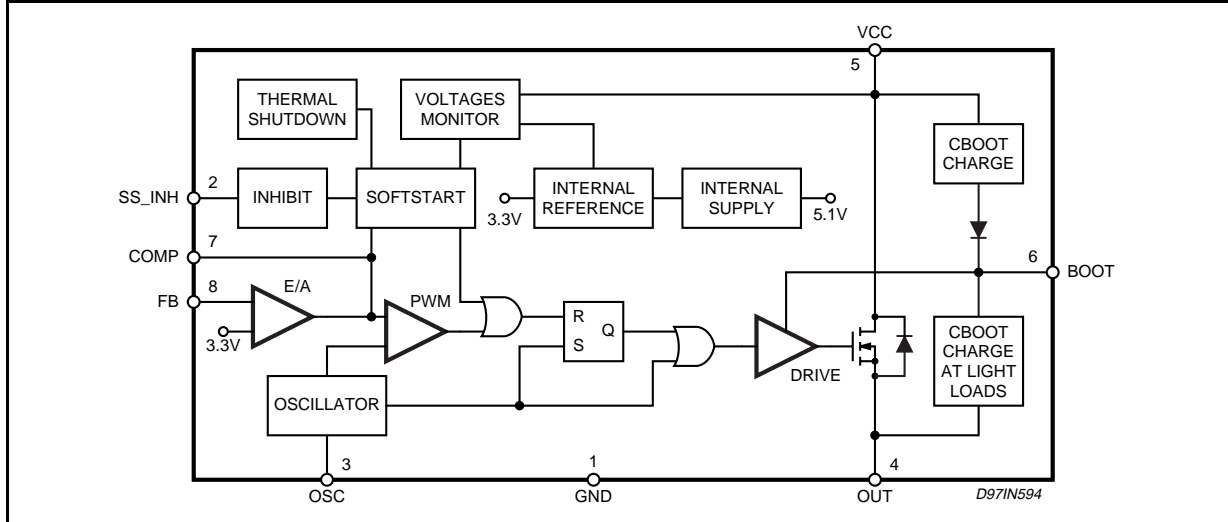

PIN CONNECTIONS

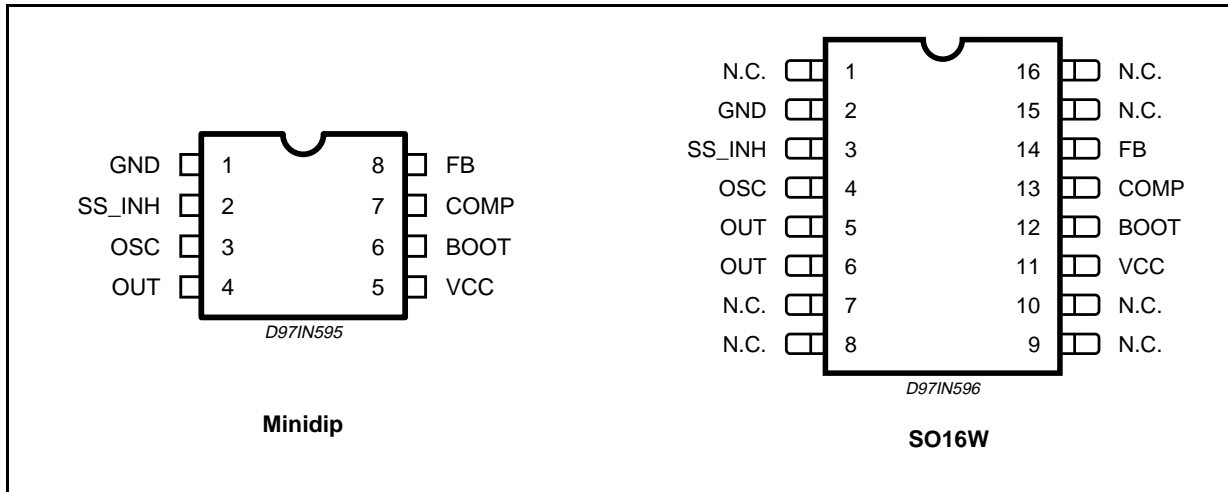

PIN FUNCTIONS

DIP	SO (*)	Name	Function
1	2	GND	Ground
2	3	SS_INH	A logic signal (active low) disables the device (sleep mode operation). A capacitor connected between this pin and ground determines the soft start time. When this pin is grounded disables the device (driven by open collector/drain).
3	4	OSC	An external resistor connected between the unregulated input voltage and this pin and a capacitor connected from this pin to ground fix the switching frequency. (Line feed forward is automatically obtained)
4	5, 6	OUT	Stepdown regulator output
5	11	Vcc	Unregulated DC input voltage
6	12	BOOT	A capacitor connected between this pin and OUT allows to drive the internal DMOS Transistors
7	13	COMP	E/A output to be used for frequency compensation
8	14	FB	Stepdown feedback input. Connecting directly to this pin results in an output voltage of 3.3V. An external resistive divider is required for higher output voltages.

(*) Pins 1, 7, 8, 9, 10, 15 and 16 are not connected.

THERMAL DATA

Symbol	Parameter	Minidip	SO16	Unit	
$R_{th(j-amb)}$	Thermal Resistance Junction to ambient	Max.	90 (*)	110 (*)	°C/W

(*) Package mounted on board.

ABSOLUTE MAXIMUM RATINGS

Symbol		Parameter	Value	Unit	
Minidip	SO16				
V_5	V_{11}	Input voltage	58	V	
V_4	V_5, V_6	Output DC voltage Output peak voltage at $t = 0.1\mu s$ $f=200KHz$	-1 -5	V V	
I_4	I_5, I_6	Maximum output current	int. limit.		
V_6-V_5	$V_{12}-V_{11}$		14	V	
V_6	V_{12}	Bootstrap voltage	70	V	
V_7	V_{13}	Analogs input voltage ($V_{CC} = 24V$)	12	V	
V_2	V_3	Analogs input voltage ($V_{CC} = 24V$)	13	V	
V_8	V_{14}	($V_{CC} = 20V$)	6 -0.3	V V	
P_{tot}		Power dissipation a $T_{amb} \leq 60^\circ C$	Minidip	1	W
			SO16	0.8	W
T_j, T_{stg}		Junction and storage temperature	-40 to 150	°C	

ELECTRICAL CHARACTERISTICS ($T_j = 25^\circ C$, $C_{osc} = 2.7nF$, $R_{osc} = 20k\Omega$, $V_{CC} = 24V$, unless otherwise specified.) * Specification Referred to T_j from 0 to $125^\circ C$

Symbol	Parameter	Test Condition	Min.	Typ.	Max.	Unit	
Dynamic Characteristic							
V_i	Operating input voltage range	$V_o = 3.3$ to $50V$; $I_o = 2A$	●	8	55	V	
V_o	Output voltage	$I_o = 0.5A$		3.33	3.36	3.39	V
		$I_o = 0.2$ to $2A$		3.292	3.36	3.427	V
		$V_{CC} = 8$ to $55V$	●	3.22	3.36	3.5	V
V_d	Dropout voltage	$V_{CC} = 10V$; $I_o = 2A$			0.58	0.733	V
			●			1.173	V
I_l	Maximum limiting current	$V_{CC} = 8$ to $55V$	●	2.5	3	3.5	A
	Efficiency	$V_o = 3.3V$; $I_o = 2A$			87		%
f_s	Switching frequency		●	90	100	110	KHz
SVRR	Supply voltage ripple rejection	$V_i = V_{CC} + 2V_{RMS}$; $V_o = V_{ref}$; $I_o = 2.5A$; $f_{ripple} = 100Hz$		60			dB
	Voltage stability of switching frequency	$V_{CC} = 8$ to $55V$			3	6	%
	Temp. stability of switching frequency	$T_j = 0$ to $125^\circ C$			4		%
Soft Start							
	Soft start charge current			30	40	50	μA
	Soft start discharge current			6	10	14	μA
Inhibit							
V_{LL}	Low level voltage		●			0.9	V
I_{sLL}	Isorce Low level		●		5	15	μA

ELECTRICAL CHARACTERISTICS (continued)

Symbol	Parameter	Test Condition	Min.	Typ.	Max.	Unit
DC Characteristics						
I_{qop}	Total operating quiescent current			4	6	mA
I_q	Quiescent current	Duty Cycle = 0; $V_{FB} = 3.8V$		2.5	3.5	mA
I_{qst-by}	Total stand-by quiescent current	$V_{inh} < 0.9V$		100	200	μA
		$V_{cc} = 55V$; $V_{inh} < 0.9V$		150	300	μA
Error Amplifier						
V_{FB}	Voltage Feedback Input		3.33	3.36	3.35	V
R_L	Line regulation	$V_{cc} = 8$ to $55V$		5	10	mV
	Ref. voltage stability vs temperature		•	0.4		$mV/^\circ C$
V_{oH}	High level output voltage	$V_{FB} = 2.5V$	10.3			V
V_{oL}	Low level output voltage	$V_{FB} = 3.8V$			0.65	V
$I_{o\ source}$	Source output current	$V_{comp} = 6V$; $V_{FB} = 2.5V$	180	220		μA
$I_{o\ sink}$	Sink output current	$V_{comp} = 6V$; $V_{FB} = 3.8V$	200	300		μA
I_b	Source bias current			2	3	μA
SVRR E/A	Supply voltage ripple rejection	$V_{comp} = V_{fb}$; $V_{cc} = 8$ to $55V$	60	80		dB
	DC open loop gain	$R_L = \infty$	50	57		dB
gm	Transconductance	$I_{comp} = -0.1$ to $0.1mA$ $V_{comp} = 6V$		2.5		mS
Oscillator Section						
	Ramp Valley		0.78	0.85	0.92	V
	Ramp peak	$V_{cc} = 8V$	2	2.15	2.3	V
		$V_{cc} = 55V$	9	9.6	10.2	V
	Maximum duty cycle		95	97		%
	Maximum Frequency	Duty Cycle = 0% $R_{osc} = 13k\Omega$, $C_{osc} = 820pF$			500	kHz

Figure 1. Test and evaluation board circuit.

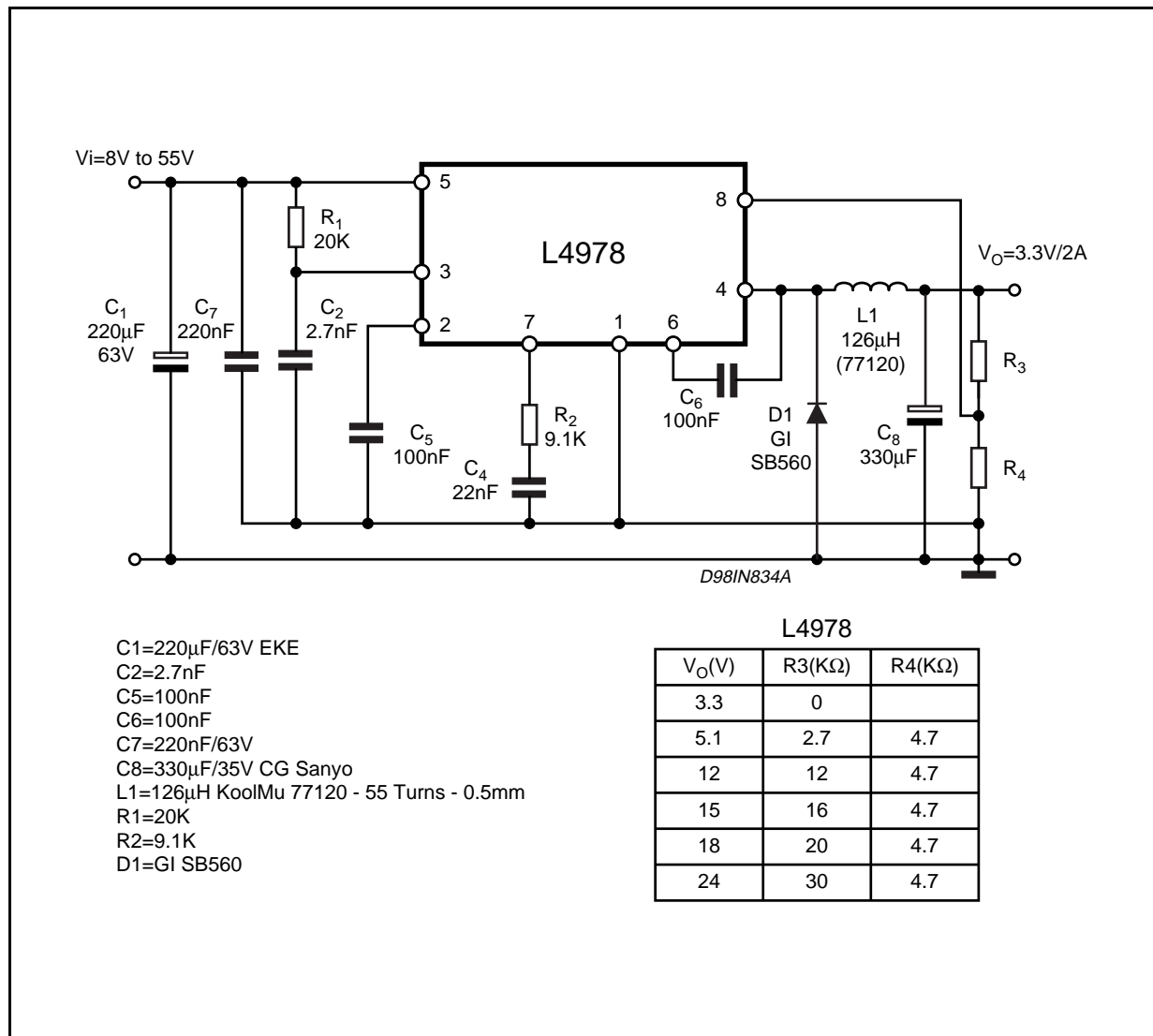

Figure 2. PCB and component layout of the figure 1.

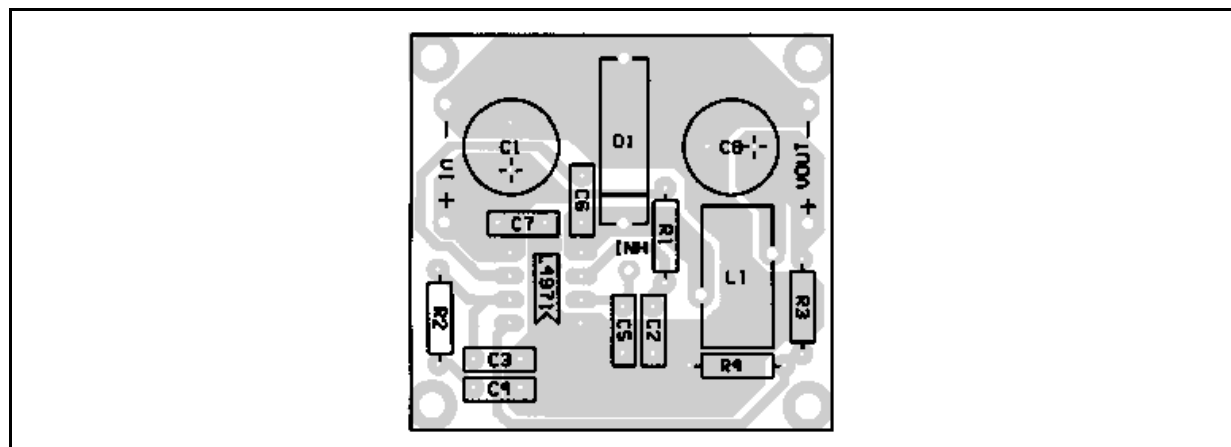

Figure 3. Quiescent drain current vs. input voltage.

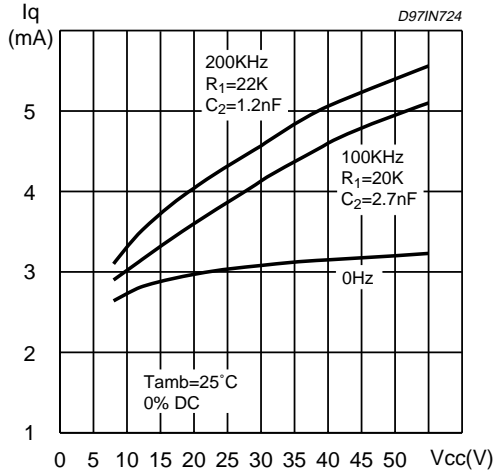

Figure 4. Quiescent current vs. junction temperature

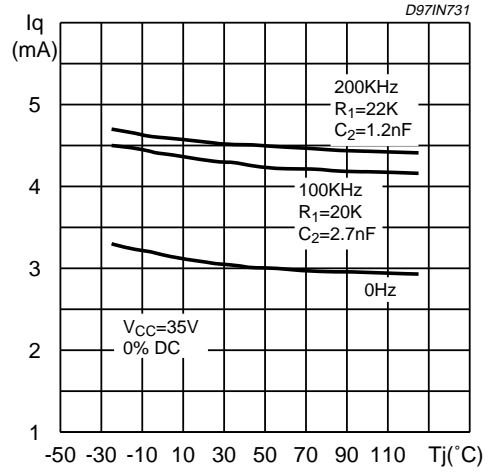

Figure 5. Stand by drain current vs. input voltage

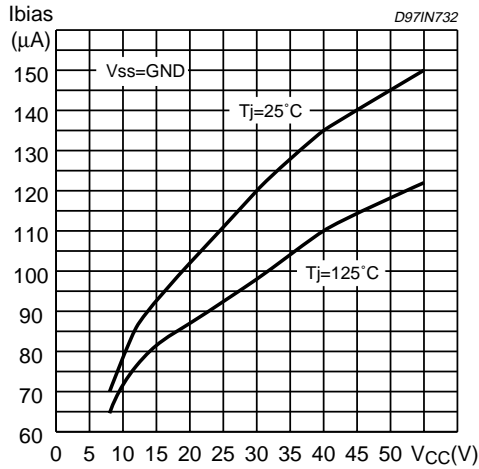

Figure 6. Line Regulation

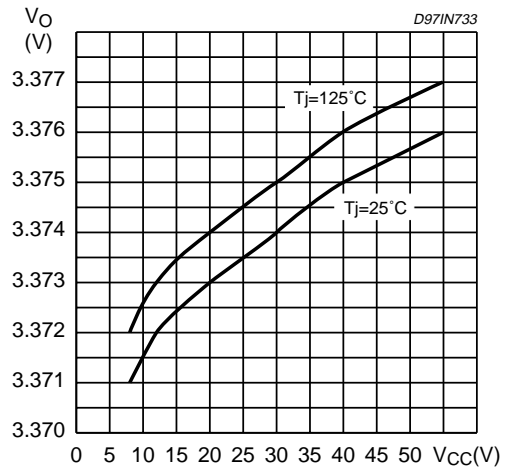

Figure 7. Load regulation

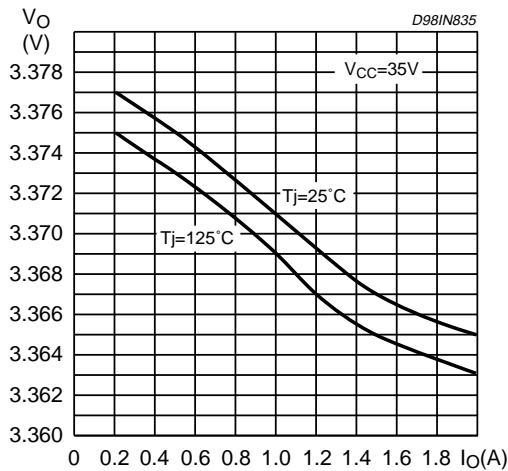

Figure 8. Switching frequency vs. R1 and C2

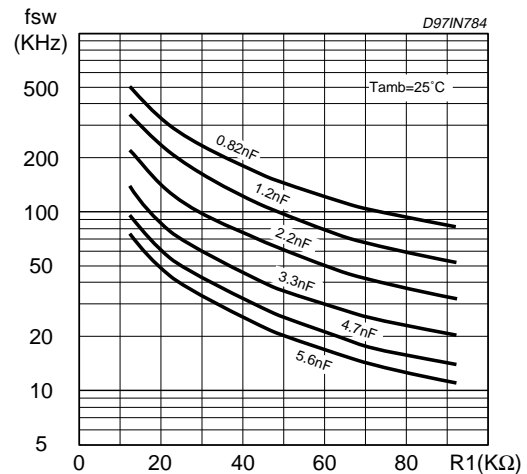

Figure 9. Switching Frequency vs. input voltage.

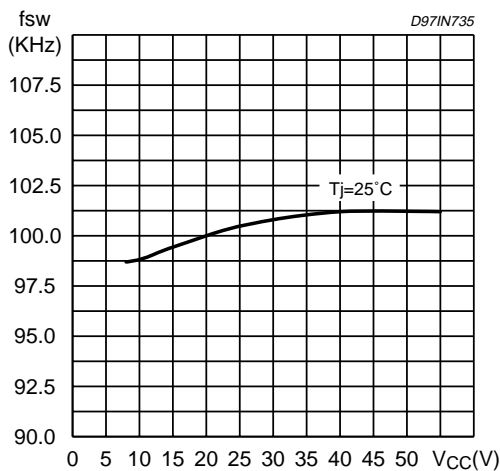

Figure 10. Switching frequency vs. junction temperature.

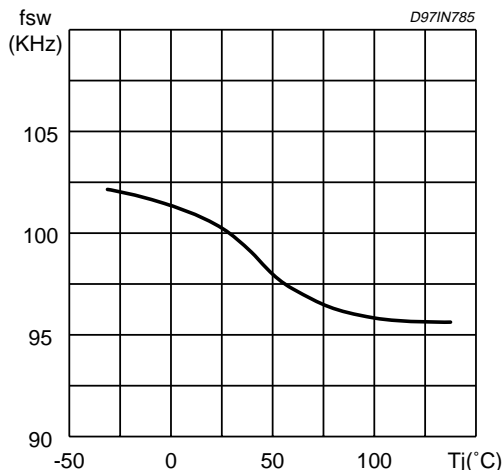

Figure 11. Dropout voltage between pin 5 and 4.

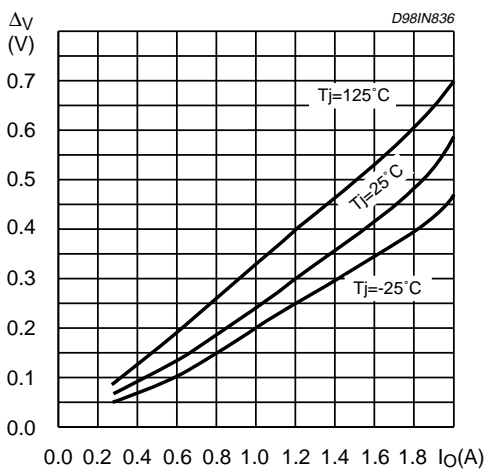

Figure 12. Efficiency vs output voltage.

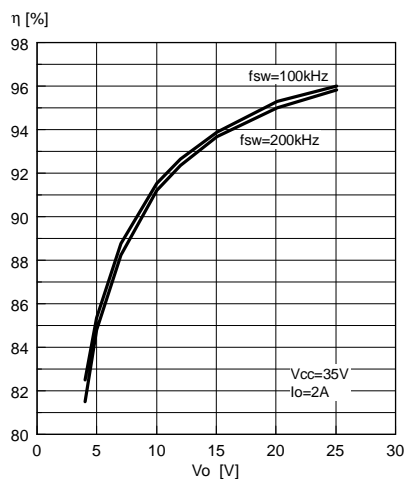

Figure 13. Efficiency vs. output current.

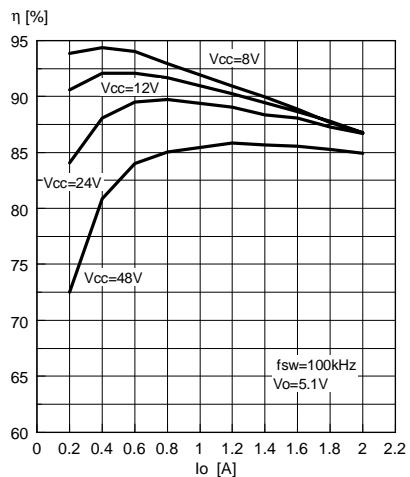

Figure 14. Efficiency vs. output current.

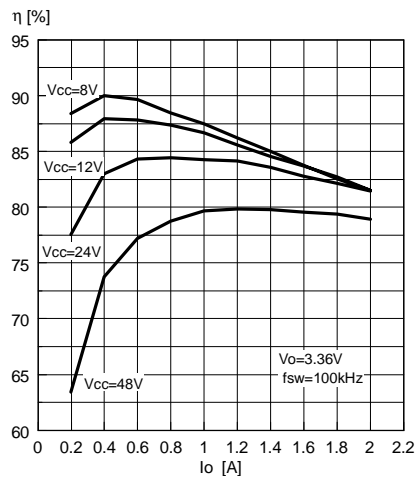

Figure 15. Efficiency vs. output current.

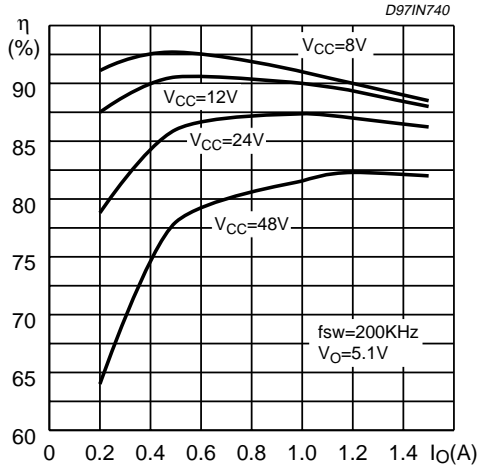

Figure 16. Efficiency vs. output current.

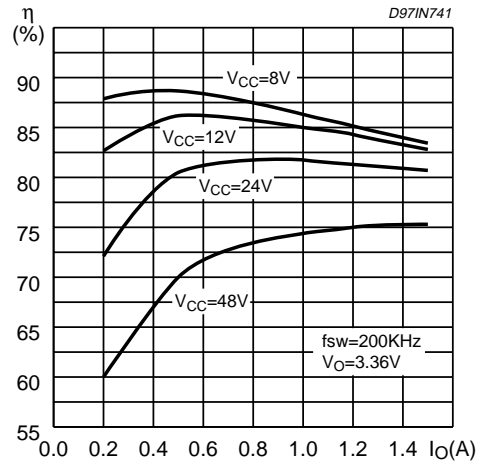

Figure 17. Efficiency vs. Vcc.

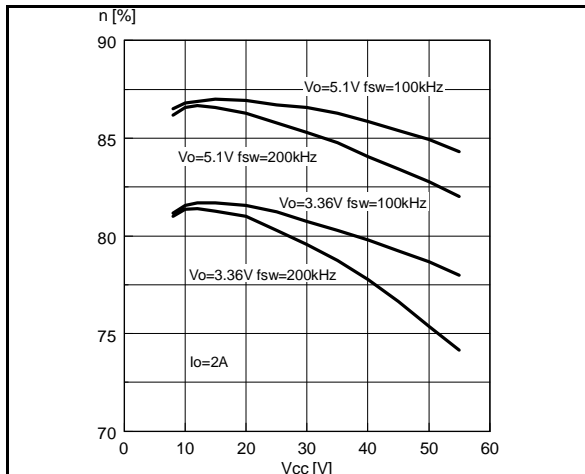

Figure 18. Power dissipation vs. Vcc.

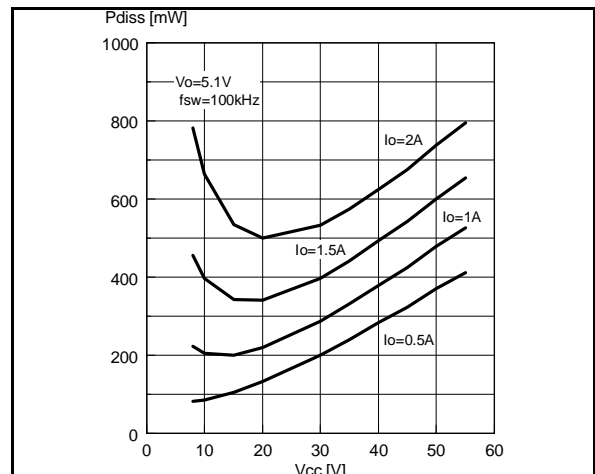

Figure 19. Device Power dissipation vs. V_O

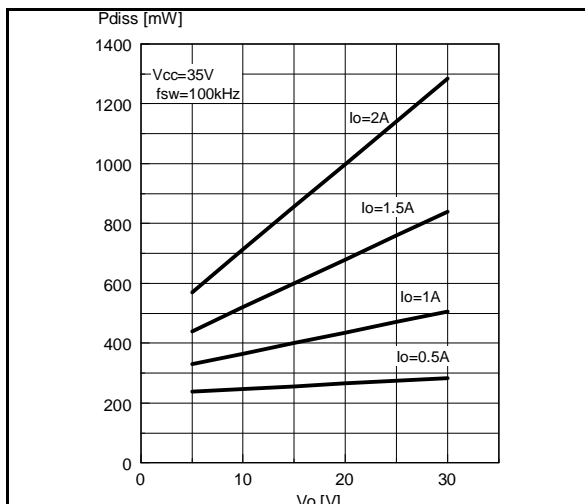

Figure 20. Pulse by pulse limiting current vs. junction temperature.

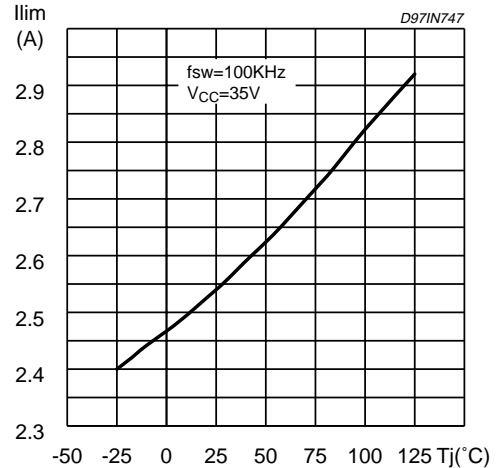

Figure 21. Load transient.

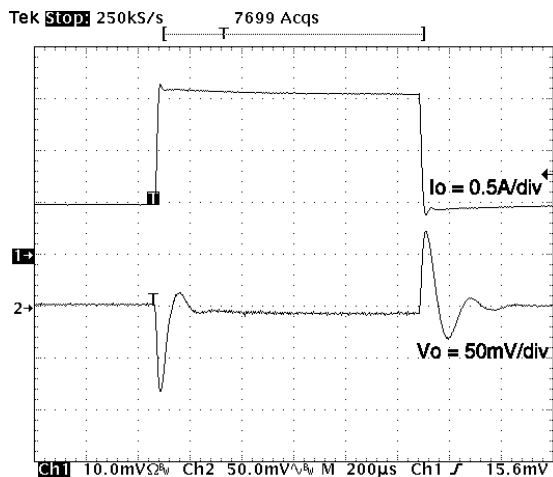

Figure 22. Line transient.

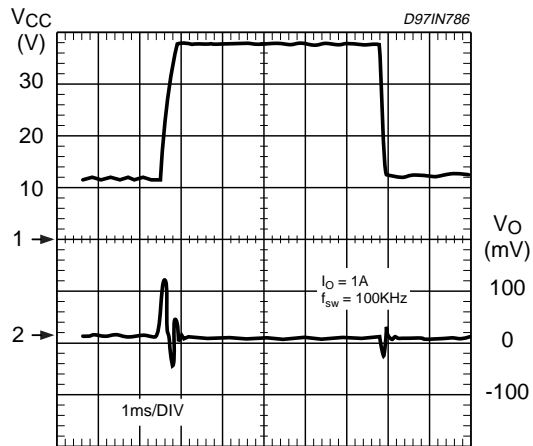

Figure 23. Soft start capacitor selection Vs inductor and Vccmax.

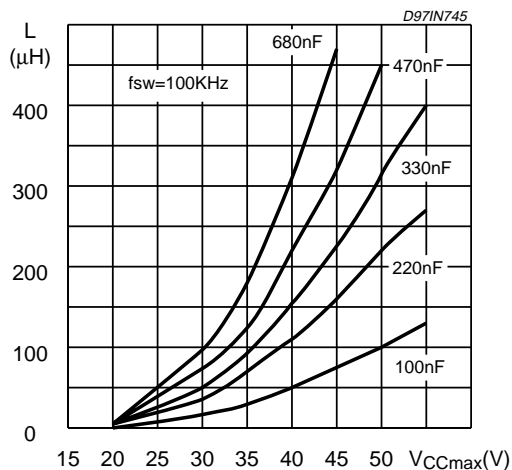

Figure 24. Soft start capacitor selection vs. Inductor and Vccmax.

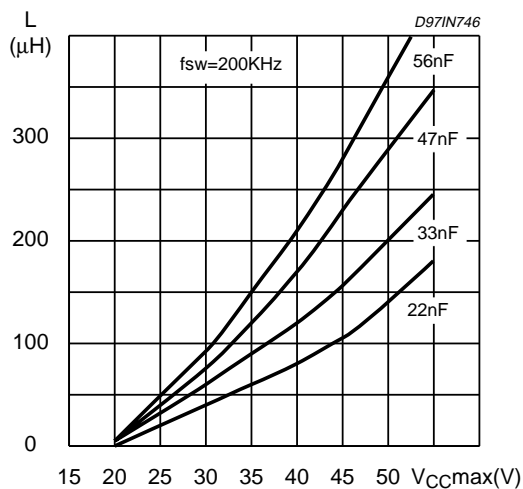
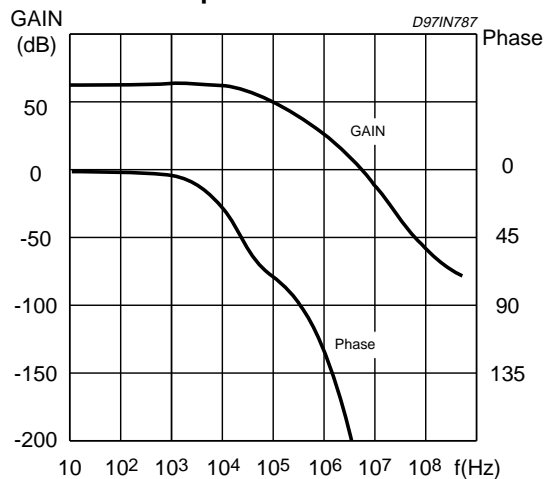
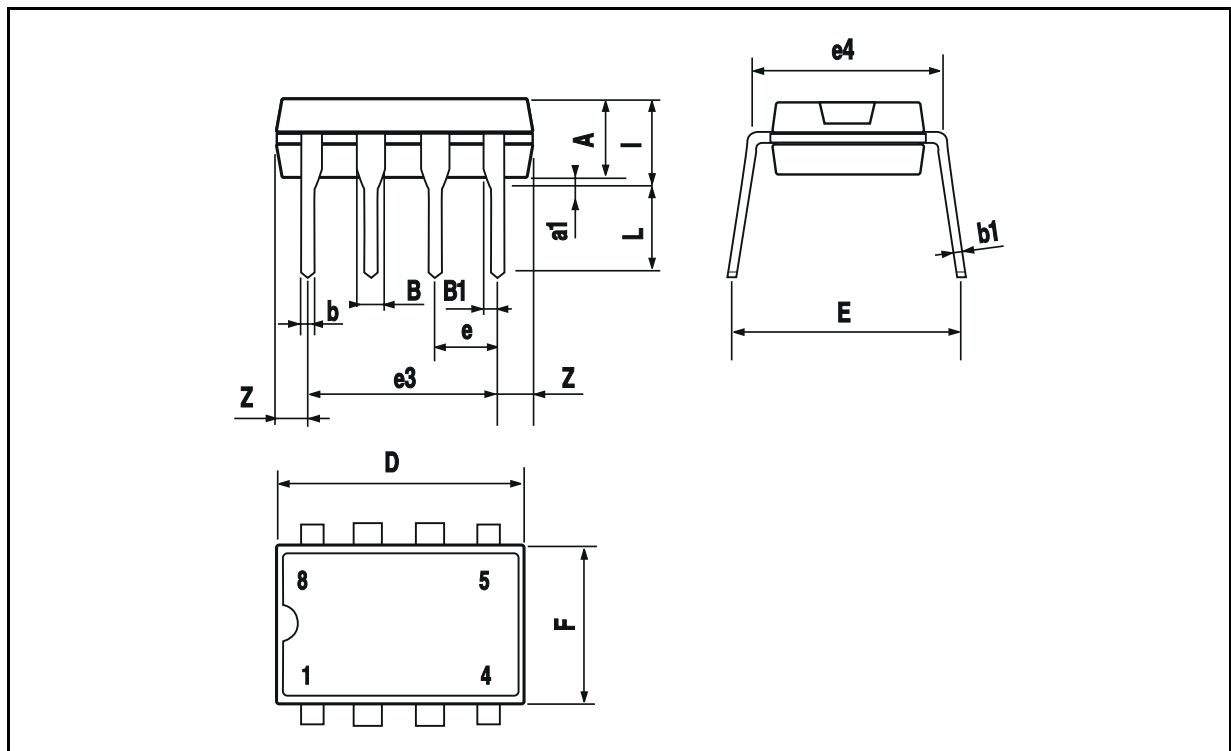

Figure 25. Open loop frequency and phase of error amplifier



MINIDIP PACKAGE MECHANICAL DATA

DIM.	mm			inch		
	MIN.	TYP.	MAX.	MIN.	TYP.	MAX.
A		3.3			0.130	
a1	0.7			0.028		
B	1.39		1.65	0.055		0.065
B1	0.91		1.04	0.036		0.041
b		0.5			0.020	
b1	0.38		0.5	0.015		0.020
D			9.8			0.386
E		8.8			0.346	
e		2.54			0.100	
e3		7.62			0.300	
e4		7.62			0.300	
F			7.1			0.280
l			4.8			0.189
L		3.3			0.130	
Z	0.44		1.6	0.017		0.063



SO16 PACKAGE MECHANICAL DATA

DIM.	mm			inch		
	MIN.	TYP.	MAX.	MIN.	TYP.	MAX.
A			2.65			0.104
a1	0.1		0.3	0.004		0.012
a2			2.45			0.096
b	0.35		0.49	0.014		0.019
b1	0.23		0.32	0.009		0.013
C		0.5			0.020	
c1	45° (typ.)					
D	10.1		10.5	0.398		0.413
E	10.0		10.65	0.394		0.419
e		1.27			0.050	
e3		8.89			0.350	
F	7.4		7.6	0.291		0.299
L	0.5		1.27	0.020		0.050
M			0.75			0.030
S	8° (max.)					

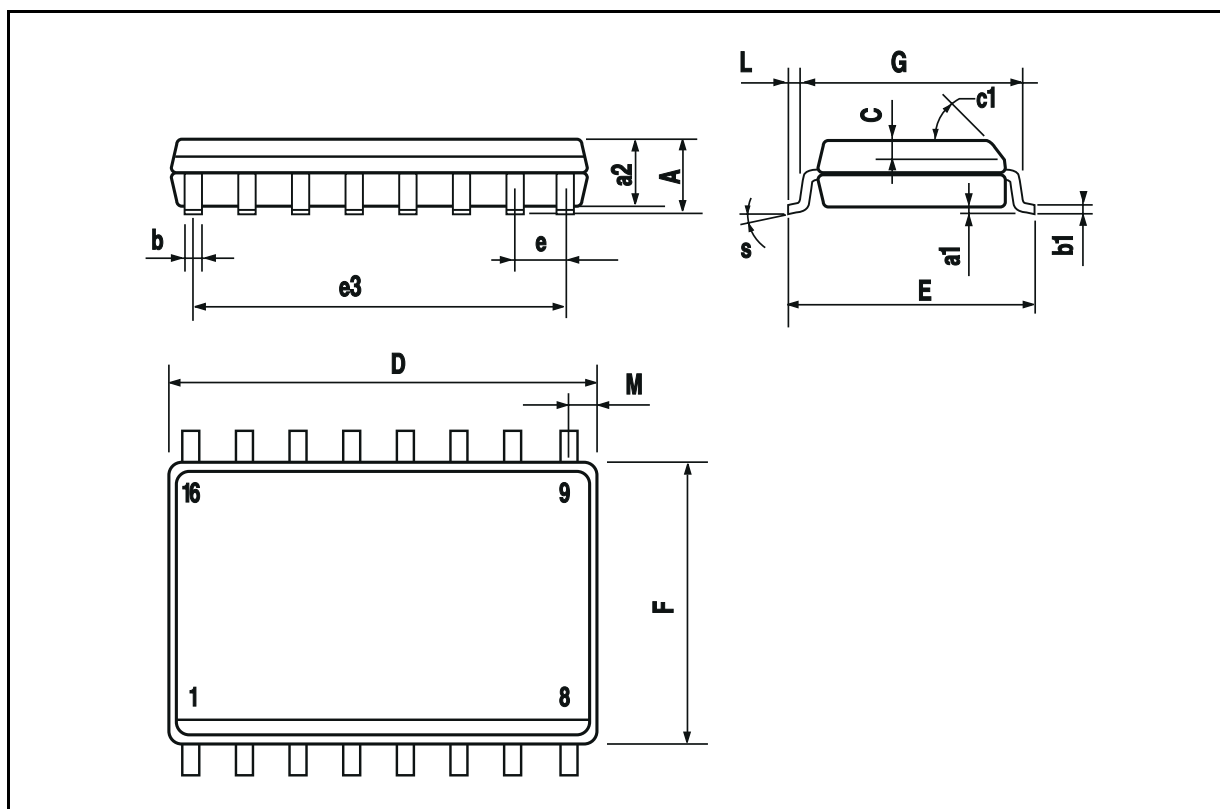

Information furnished is believed to be accurate and reliable. However, STMicroelectronics assumes no responsibility for the consequences of use of such information nor for any infringement of patents or other rights of third parties which may result from its use. No license is granted by implication or otherwise under any patent or patent rights of STMicroelectronics. Specification mentioned in this publication are subject to change without notice. This publication supersedes and replaces all information previously supplied. STMicroelectronics products are not authorized for use as critical components in life support devices or systems without express written approval of STMicroelectronics.

The ST logo is a registered trademark of STMicroelectronics

© 1999 STMicroelectronics – Printed in Italy – All Rights Reserved

STMicroelectronics GROUP OF COMPANIES

Australia - Brazil - China - Finland - France - Germany - Hong Kong - India - Italy - Japan - Malaysia - Malta - Morocco -
Singapore - Spain - Sweden - Switzerland - United Kingdom - U.S.A.

<http://www.st.com>