



LTC1278

# 12-Bit, 500ksps Sampling A/D Converter with Shutdown

## FEATURES

- Single Supply 5V or  $\pm 5V$  Operation
- Two Speed Grades, 500ksps (LTC1278-5) 400ksps (LTC1278-4)
- 70dB S/(N + D) and 74dB THD at Nyquist
- No Missing Codes Over Temperature
- 75mW (Typ) Power Dissipation
- Power Shutdown with Instant Wake-Up
- Internal Reference Can Be Overdriven Externally
- Internal Synchronized Clock; No Clock Required
- High Impedance Analog Input
- 0V to 5V or  $\pm 2.5V$  Input Range
- New Flexible, Friendly Parallel Interface to DSPs and FIFOs
- 24-Pin SOL Packages

## APPLICATIONS

- High Speed Data Acquisition
- Digital Signal Processing
- Multiplexed Data Acquisition Systems
- Audio and Telecom Processing
- Spectrum Analysis

## DESCRIPTION

The LTC1278 is a 1.6 $\mu$ s, 500ksps, sampling 12-bit A/D converter which draws only 75mW from a single 5V or  $\pm 5V$  supplies. This easy-to-use device comes complete with a 200ns sample-and-hold, a precision reference and an internally trimmed clock. Unipolar and bipolar conversion modes add to the flexibility of the ADC. The low power dissipation is made even more attractive by a 8.5mW power-down feature. Instant wake-up from shutdown allows the converter to be powered down even during brief inactive periods.

The LTC1278 converts 0V to 5V unipolar inputs from a single 5V supply and  $\pm 2.5V$  bipolar inputs from  $\pm 5V$  supplies. Maximum DC specs include  $\pm 1$ LSB INL and  $\pm 1$ LSB DNL. Outstanding guaranteed AC performance includes 70dB S/(N + D) and 78dB THD at the input frequency of 100kHz over temperature.

The internal clock is trimmed for 1.6 $\mu$ s conversion time. The clock automatically synchronizes to each sample command, eliminating problems with asynchronous clock noise found in competitive devices. A separate convert start input and a data ready signal (BUSY) ease connections to FIFOs, DSPs and microprocessors.

## TYPICAL APPLICATION

Single 5V Supply, 500kHz, 12-Bit Sampling A/D Converter

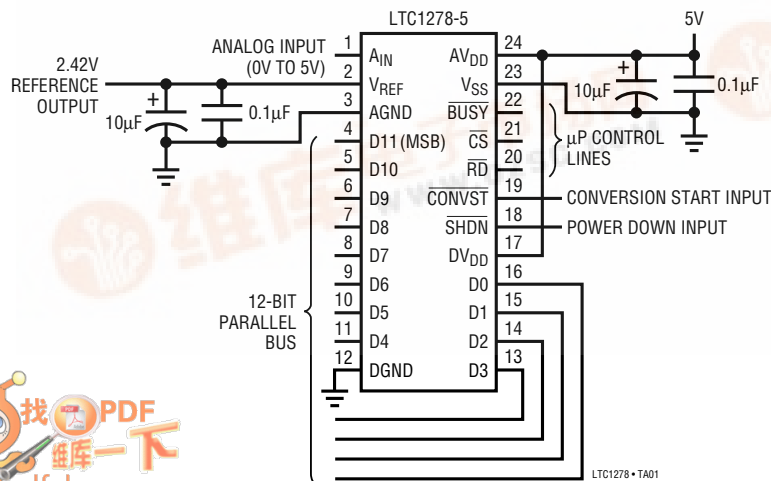

Effective Bits and Signal-to-(Noise + Distortion) vs Input Frequency

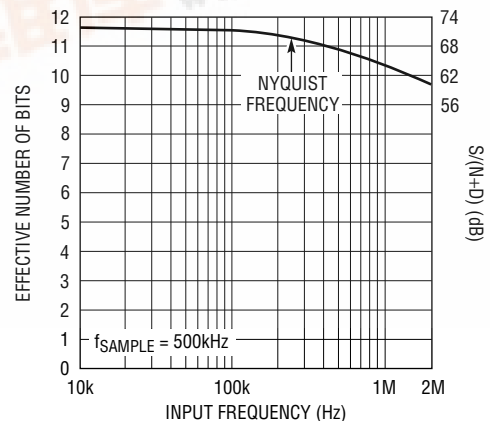

# LTC1278

## ABSOLUTE MAXIMUM RATINGS

$AV_{DD} = DV_{DD} = V_{DD}$  (Notes 1, 2)

Supply Voltage ( $V_{DD}$ )	12V
Negative Supply Voltage ( $V_{SS}$ )	
Bipolar Operation Only	–6V to GND
Total Supply Voltage ( $V_{DD}$ to $V_{SS}$ )	
Bipolar Operation Only	12V
Analog Input Voltage (Note 3)	
Unipolar Operation	–0.3V to $V_{DD} + 0.3V$
Bipolar Operation	$V_{SS} - 0.3V$ to $V_{DD} + 0.3V$
Digital Input Voltage (Note 4)	
Unipolar Operation	–0.3V to 12V
Bipolar Operation	$V_{SS} - 0.3V$ to 12V
Digital Output Voltage	
Unipolar Operation	–0.3V to $V_{DD} + 0.3V$
Bipolar Operation	$V_{SS} - 0.3V$ to $V_{DD} + 0.3V$
Power Dissipation	500mW
Operating Temperature Range	
LTC1278-4C, LTC1278-5C	0°C to 70°C
LTC1278-4I	–40°C to 85°C
Storage Temperature Range	–65°C to 150°C
Lead Temperature (Soldering, 10 sec)	300°C

## PACKAGE/ORDER INFORMATION

<p>TOP VIEW</p> <p>N PACKAGE 24-LEAD PLASTIC DIP</p> <p>S PACKAGE 24-LEAD PLASTIC SOL</p> <p><math>T_{JMAX} = 110^{\circ}C, \theta_{JA} = 100^{\circ}C/W</math> (N) <math>T_{JMAX} = 110^{\circ}C, \theta_{JA} = 130^{\circ}C/W</math> (S)</p>	ORDER PART NUMBER
	<p>LTC1278-4CN</p> <p>LTC1278-5CN</p> <p>LTC1278-4IN</p> <p>LTC1278-4CS</p> <p>LTC1278-5CS</p> <p>LTC1278-4IS</p>

Consult factory for Military grade parts.

## CONVERTER CHARACTERISTICS With Internal Reference (Notes 5, 6)

PARAMETER	CONDITIONS	LTC1278-4/LTC1278-5			UNITS
		MIN	TYP	MAX	
Resolution (No Missing Codes)		●	12		Bit
Integral Linearity Error	(Note 7)	●		±1	LSB
Differential Linearity Error		●		±1	LSB
Offset Error	(Note 8)	●		±4	LSB
Gain Error				±6	LSB
Gain Error Tempco	$I_{OUT(REF)} = 0$	●	±10	±45	ppm/°C

## ANALOG INPUT (Note 5)

SYMBOL	PARAMETER	CONDITIONS	LTC1278-4/LTC1278-5			UNITS
			MIN	TYP	MAX	
$V_{IN}$	Analog Input Range (Note 9)	$4.95V \leq V_{DD} \leq 5.25V$ (Unipolar)	●	0 to 5		V
		$4.75V \leq V_{DD} \leq 5.25V, -5.25V \leq V_{SS} \leq -2.45V$ (Bipolar)	●	±2.5		V
$I_{IN}$	Analog Input Leakage Current	$\overline{CS} = \text{High}$	●		±1	μA
$C_{IN}$	Analog Input Capacitance	Between Conversions (Sample Mode)		45		pF
		During Conversions (Hold Mode)		5		pF

**DYNAMIC ACCURACY** (Note 5)

SYMBOL	PARAMETER	CONDITIONS	LTC1278-4/LTC1278-5			UNITS
			MIN	TYP	MAX	
S/(N + D)	Signal-to-Noise Plus Distortion Ratio	100kHz Input Signal 250kHz Input Signal	● 70	72 70		dB dB
THD	Total Harmonic Distortion	100kHz Input Signal	●	-80	-78	dB
	First 5 Harmonics	250kHz Input Signal	●	-74		dB
	Peak Harmonic or Spurious Noise	100kHz Input Signal	●	-84	-82	dB
		250kHz Input Signal	●	-74		dB
IMD	Intermodulation Distortion	$f_{IN1} = 99.37\text{kHz}$ , $f_{IN2} = 102.4\text{kHz}$		-82		dB
		$f_{IN1} = 249.37\text{kHz}$ , $f_{IN2} = 252.4\text{kHz}$		-70		dB
	Full Power Bandwidth			4		MHz
	Full Linear Bandwidth (S/(N + D) $\geq$ 68dB)			350		kHz

**INTERNAL REFERENCE CHARACTERISTICS** (Note 5)

PARAMETER	CONDITIONS	LTC1278-4/LTC1278-5			UNITS
		MIN	TYP	MAX	
$V_{REF}$ Output Voltage	$I_{OUT} = 0$	2.400	2.420	2.440	V
$V_{REF}$ Output Tempco	$I_{OUT} = 0$	●	$\pm 10$	$\pm 45$	ppm/ $^{\circ}\text{C}$
$V_{REF}$ Line Regulation	$4.95\text{V} \leq V_{DD} \leq 5.25\text{V}$ $-5.25\text{V} \leq V_{SS} \leq -4.95\text{V}$		0.01		LSB/V
			0.01		LSB/V
$V_{REF}$ Load Regulation	$0\text{V} \leq  I_{OUT}  \leq 1\text{mA}$		2		LSB/mA

**DIGITAL INPUTS AND DIGITAL OUTPUTS** (Note 5)

SYMBOL	PARAMETER	CONDITIONS	LTC1278-4/LTC1278-5			UNITS
			MIN	TYP	MAX	
$V_{IH}$	High Level Input Voltage	$V_{DD} = 5.25\text{V}$	● 2.4			V
$V_{IL}$	Low Level Input Voltage	$V_{DD} = 4.95\text{V}$	●		0.8	V
$I_{IN}$	Digital Input Current	$V_{IN} = 0\text{V}$ to $V_{DD}$	●		$\pm 10$	$\mu\text{A}$
$C_{IN}$	Digital Input Capacitance			5		pF
$V_{OH}$	High Level Output Voltage	$V_{DD} = 4.95\text{V}$ $I_O = -10\mu\text{A}$ $I_O = -200\mu\text{A}$	●	4	4.7	V V
		$V_{DD} = 4.95\text{V}$ $I_O = 160\mu\text{A}$ $I_O = 1.6\text{mA}$	●		0.05 0.10	V V
$I_{OZ}$	High Z Output Leakage D11 to D0	$V_{OUT} = 0\text{V}$ to $V_{DD}$ , $\overline{\text{CS}}$ High	●		$\pm 10$	$\mu\text{A}$
$C_{OZ}$	High Z Output Capacitance D11 to D0	$\overline{\text{CS}}$ High (Note 9)	●		15	pF
$I_{SOURCE}$	Output Source Current	$V_{OUT} = 0\text{V}$		-10		mA
$I_{SINK}$	Output Sink Current	$V_{OUT} = V_{DD}$		10		mA

# LTC1278

## POWER REQUIREMENTS (Note 5)

SYMBOL	PARAMETER	CONDITIONS	LTC1278-4/LTC1278-5			UNITS
			MIN	TYP	MAX	
V <sub>DD</sub>	Positive Supply Voltage (Notes 10, 11)	Unipolar	4.95		5.25	V
		Bipolar	4.75		5.25	V
V <sub>SS</sub>	Negative Supply Voltage (Note 10)	Bipolar Only	-2.45		-5.25	V
I <sub>DD</sub>	Positive Supply Current	f <sub>SAMPLE</sub> = 500ksps	●	15.0	29.5	mA
		SHDN = 0V	●	1.7	3.0	mA
I <sub>SS</sub>	Negative Supply Current	f <sub>SAMPLE</sub> = 500ksps, V <sub>SS</sub> = -5V	●	0.12	0.30	mA
P <sub>D</sub>	Power Dissipation	f <sub>SAMPLE</sub> = 500ksps	●	75.0	150	mW
		SHDN = 0V	●	8.5	15	mW

## TIMING CHARACTERISTICS (Note 5)

SYMBOL	PARAMETER	CONDITIONS	LTC1278-4/LTC1278-5			UNITS	
			MIN	TYP	MAX		
f <sub>SAMPLE(MAX)</sub>	Maximum Sampling Frequency	LTC1278-4	●	400		kHz	
		LTC1278-5	●	500			
t <sub>SAMPLE(MIN)</sub>	Minimum Throughput Time (Acquisition Time Plus Conversion Time)	LTC1278-4	●		2.5	μs	
		LTC1278-5	●		2.0	μs	
t <sub>CONV</sub>	Conversion Time	LTC1278-4		2.0	2.3	μs	
		LTC1278-5		1.6	1.85	μs	
t <sub>ACQ</sub>	Acquisition Time			200	ns		
t <sub>1</sub>	$\overline{CS}\downarrow$ to $\overline{RD}\downarrow$ Setup Time	(Notes 9, 10)	●	0		ns	
t <sub>2</sub>	$\overline{CS}\downarrow$ to $\overline{CONVST}\downarrow$ Setup Time	(Notes 9, 10)	●	20		ns	
t <sub>3</sub>	SHDN $\uparrow$ to $\overline{CONVST}\downarrow$ Wake-Up Time	(Note 10)			350	ns	
t <sub>4</sub>	$\overline{CONVST}$ Low Time	(Notes 10, 12)	●	40		ns	
t <sub>5</sub>	$\overline{CONVST}\downarrow$ to $\overline{BUSY}\downarrow$ Delay	C <sub>L</sub> = 100pF		40	110	ns	
		Commercial	●		130	ns	
		Industrial	●		140	ns	
t <sub>6</sub>	Data Ready Before $\overline{BUSY}\uparrow$	C <sub>L</sub> = 100pF	●	20	40	ns	
t <sub>7</sub>	Wait Time $\overline{RD}\downarrow$ After $\overline{BUSY}\uparrow$	Mode 2, (see Figure 14) (Note 9)	●	-20		ns	
t <sub>8</sub>	Data Access Time After $\overline{RD}\downarrow$	C <sub>L</sub> = 20pF (Note 9)		50	90	ns	
		Commercial	●		110	ns	
		Industrial	●		120	ns	
		C <sub>L</sub> = 100pF		70	125	ns	
		Commercial	●		150	ns	
		Industrial	●		170	ns	
t <sub>9</sub>	Bus Relinquish Time			20	30	75	ns
		Commercial	●	20		85	ns
		Industrial	●	20		90	ns
t <sub>10</sub>	$\overline{RD}$ Low Time	(Note 9)	●	t <sub>8</sub>		ns	
t <sub>11</sub>	$\overline{CONVST}$ High Time	(Notes 9, 12)	●	40		ns	
t <sub>12</sub>	Aperture Delay of Sample-and-Hold	Jitter <50ps			15	ns	

## TIMING CHARACTERISTICS (Note 5)

The ● indicates specifications which apply over the full operating temperature range; all other limits and typicals  $T_A = 25^\circ\text{C}$ .

**Note 1:** Absolute maximum ratings are those values beyond which the life of a device may be impaired.

**Note 2:** All voltage values are with respect to ground with DGND and AGND wired together (unless otherwise noted).

**Note 3:** When these pin voltages are taken below  $V_{SS}$  (ground for unipolar mode) or above  $V_{DD}$ , they will be clamped by internal diodes. This product can handle input currents greater than 60mA below  $V_{SS}$  (ground for unipolar mode) or above  $V_{DD}$  without latch-up.

**Note 4:** When these pin voltages are taken below  $V_{SS}$  (ground for unipolar mode), they will be clamped by internal diodes. This product can handle input currents greater than 60mA below  $V_{SS}$  (ground for unipolar mode) without latch-up. These pins are not clamped to  $V_{DD}$ .

**Note 5:**  $AV_{DD} = DV_{DD} = V_{DD} = 5\text{V}$ , ( $V_{SS} = -5\text{V}$  for bipolar mode),  $f_{\text{SAMPLE}} = 400\text{kHz}$  (LTC1278-4),  $500\text{kHz}$  (LTC1278-5),  $t_r = t_f = 5\text{ns}$  unless otherwise specified.

**Note 6:** Linearity, offset and full scale specifications apply for unipolar and bipolar modes.

**Note 7:** Integral nonlinearity is defined as the deviation of a code from a straight line passing through the actual endpoints of the transfer curve. The deviation is measured from the center of the quantization band.

**Note 8:** Bipolar offset is the offset voltage measured from  $-1/2\text{LSB}$  when the output code flickers between 0000 0000 0000 and 1111 1111 1111.

**Note 9:** Guaranteed by design, not subject to test.

**Note 10:** Recommended operating conditions.

**Note 11:**  $A_{IN}$  must not exceed  $V_{DD}$  or fall below  $V_{SS}$  by more than 50mV for specified accuracy. Therefore the minimum supply voltage for the unipolar mode is 4.95V. The minimum for the bipolar mode is 4.75V,  $-2.45\text{V}$ .

**Note 12:** The falling  $\overline{\text{CONVST}}$  edge starts a conversion. If  $\overline{\text{CONVST}}$  returns high at a bit decision point during the conversion it can create small errors. For best performance ensure that  $\overline{\text{CONVST}}$  returns high either within 120ns after conversion start (i.e., before the first bit decision) or after  $\overline{\text{BUSY}}$  rises (i.e., after the last bit test). See mode 1a and 1b (Figures 12 and 13) timing diagrams.

## TYPICAL PERFORMANCE CHARACTERISTICS

**Integral Nonlinearity vs Output Code**

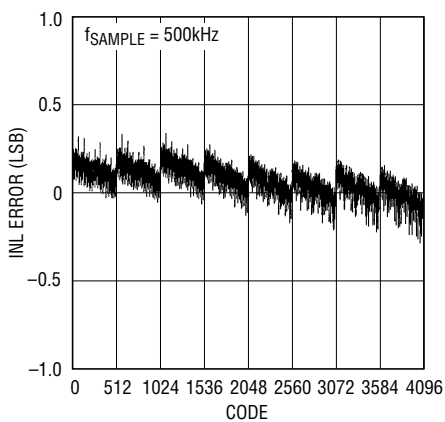

LT1278 G1

**Differential Nonlinearity vs Output Code**

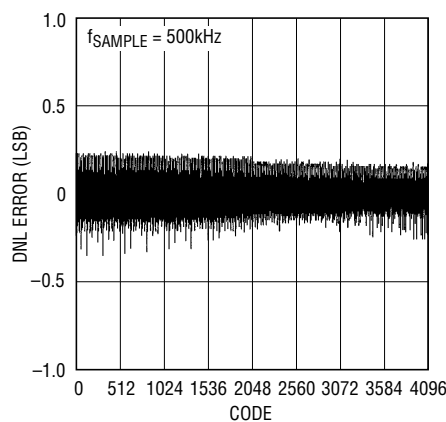

LT1278 G2

**ENOBs and S/(N + D) vs Input Frequency**

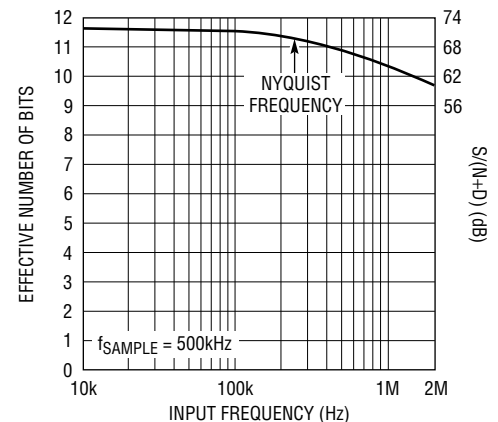

LT1278 G4

## TYPICAL PERFORMANCE CHARACTERISTICS

**S/(N + D) vs Input Frequency and Amplitude**

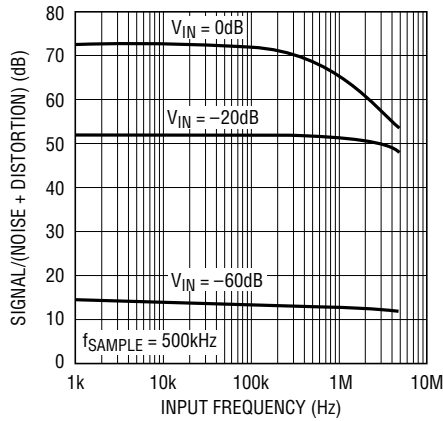

LTC1278 G10

**Signal-to-Noise Ratio (without Harmonics) vs Input Frequency**

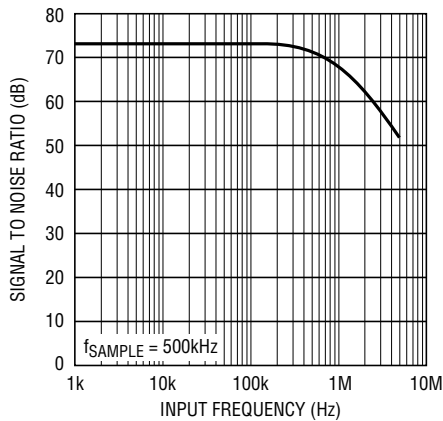

LTC1278 G5

**Distortion vs Input Frequency**

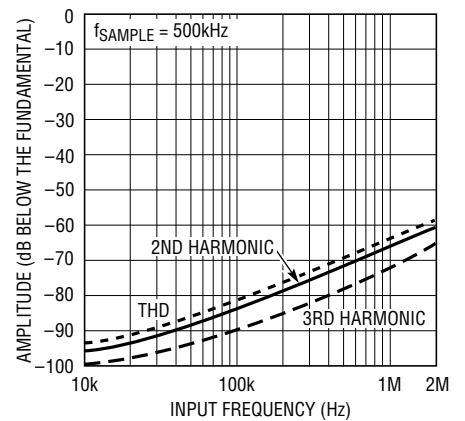

LTC1278 G6

**Spurious Free Dynamic Range vs Input Frequency**

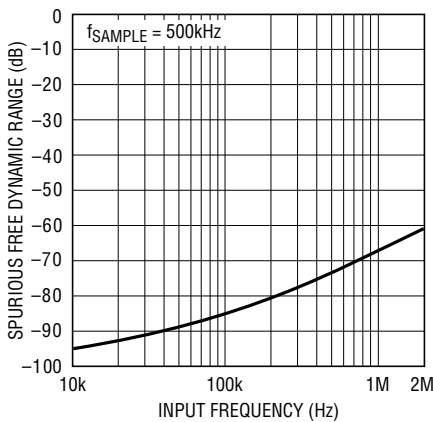

LTC1278 G11

**Intermodulation Distortion Plot**

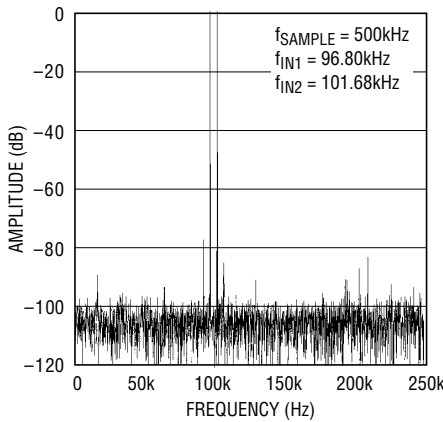

LTC1278 G8

**Acquisition Time vs Source Impedance**

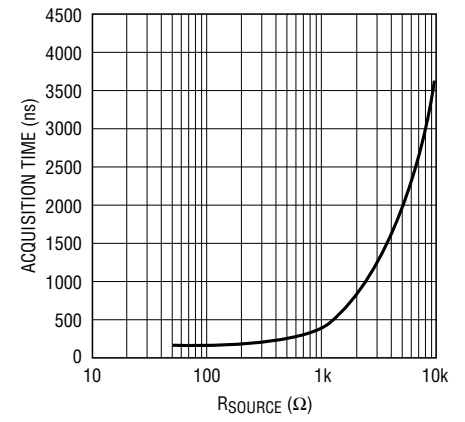

LTC1278 G9

**Supply Current vs Temperature**

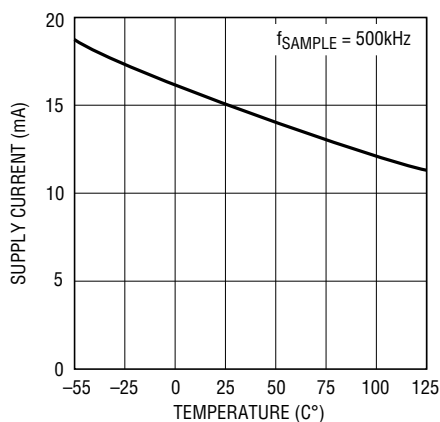

LTC1278 G3

**Power Supply Feedthrough vs Ripple Frequency**

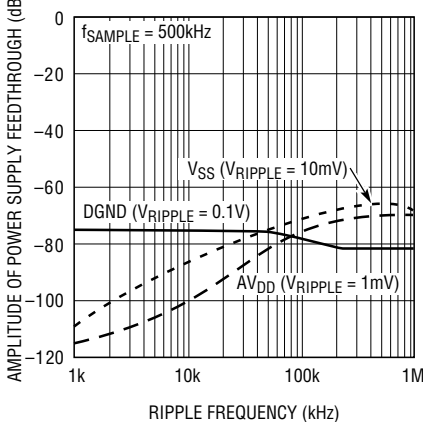

LTC1278 G7

**Reference Voltage vs Load Current**

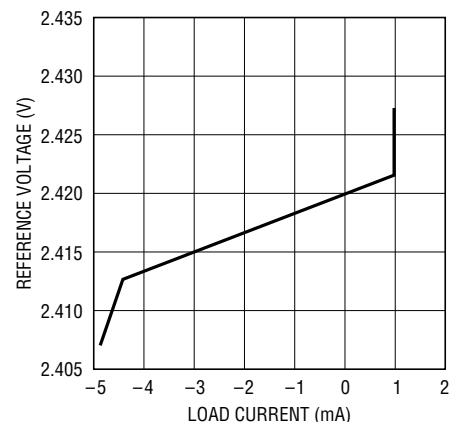

LTC1278 G12

## PIN FUNCTIONS

**$A_{IN}$  (Pin 1):** Analog Input. 0V to 5V (Unipolar),  $\pm 2.5V$  (Bipolar).

**$V_{REF}$  (Pin 2):** 2.42V Reference Output. Bypass to AGND (10 $\mu F$  tantalum in parallel with 0.1 $\mu F$  ceramic).

**AGND (Pin 3):** Analog Ground.

**D11 to D4 (Pins 11 to 4):** Three-State Data Outputs. D11 is the Most Significant Bit.

**DGND (Pin 12):** Digital Ground.

**D3 to D0 (Pins 13 to 16):** Three-State Data Outputs.

**DV<sub>DD</sub> (Pin 17):** Digital Power Supply, 5V. Tie to AV<sub>DD</sub> pin.

**SHDN (Pin 18):** Power Shutdown.

**CONVST (Pin 19):** Conversion Start Signal. This active low signal starts a conversion on its falling edge (to recognize CONVST, CS has to be low).

**$\overline{RD}$  (Pin 20):** READ Input. This enables the output drivers when  $\overline{CS}$  is low.

**$\overline{CS}$  (Pin 21):** The CHIP SELECT input must be low for the ADC to recognize  $\overline{CONVST}$  and  $\overline{RD}$  inputs.

**$\overline{BUSY}$  (Pin 22):** The  $\overline{BUSY}$  output shows the converter status. It is low when a conversion is in progress.

**$V_{SS}$  (Pin 23):** Negative Supply.  $-5V$  for bipolar operation. Bypass to AGND with 0.1 $\mu F$  ceramic. Analog ground for unipolar operation.

**AV<sub>DD</sub> (Pin 24):** Positive Supply, 5V. Bypass to AGND (10 $\mu F$  tantalum in parallel with 0.1 $\mu F$  ceramic).

## FUNCTIONAL BLOCK DIAGRAM

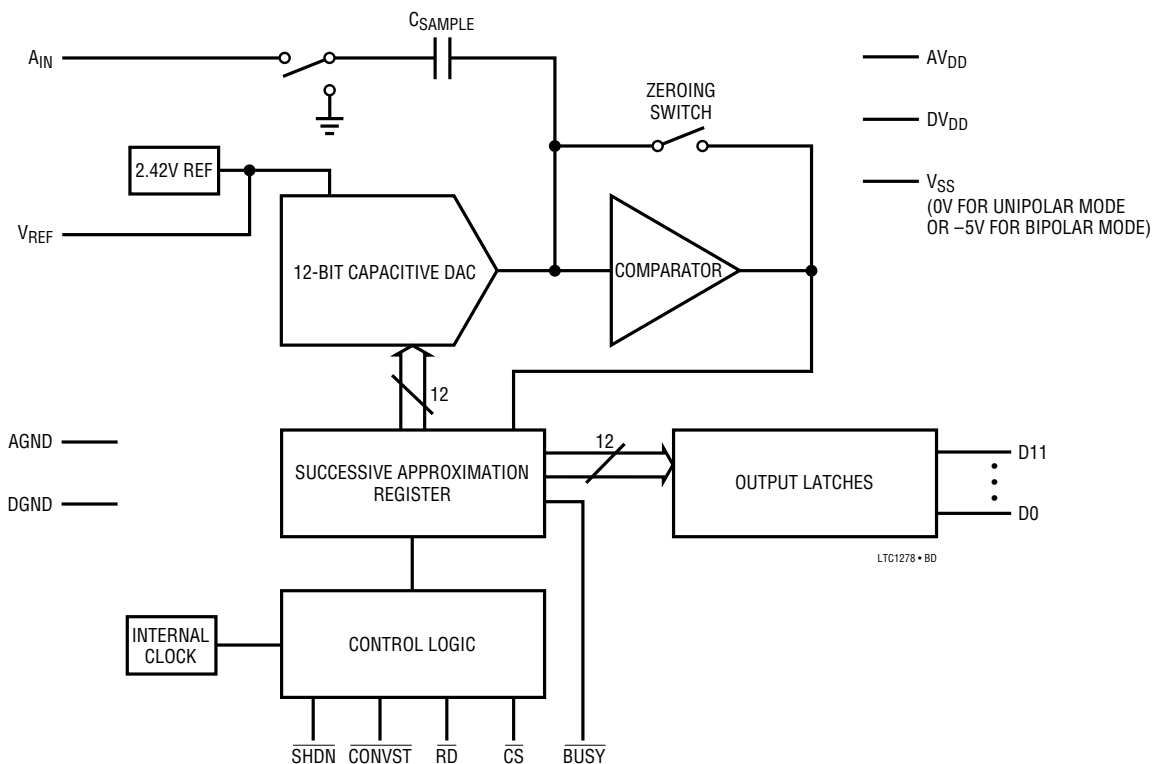

# LTC1278

## TEST CIRCUITS

### Load Circuits for Access Timing

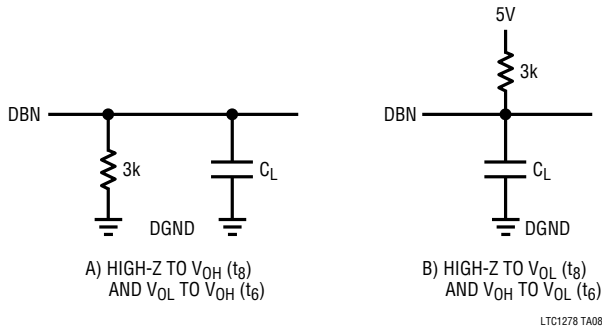

### Load Circuits for Output Float Delay

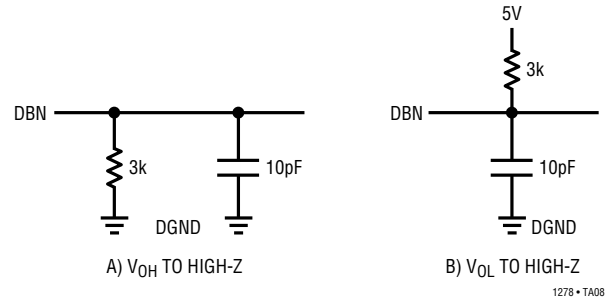

## TIMING DIAGRAMS

### $\overline{CS}$ to $\overline{RD}$ Setup Timing

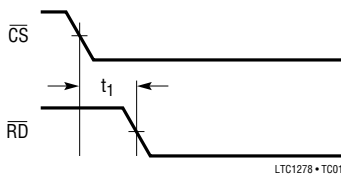

### $\overline{CS}$ to $\overline{CONVST}$ Setup Timing

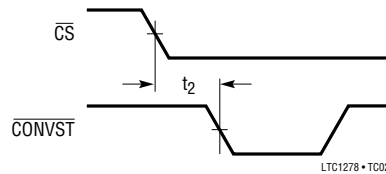

### $\overline{SHDN}$ to $\overline{CONVST}$ Wake-Up Timing

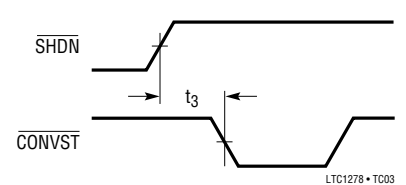

## APPLICATIONS INFORMATION

### CONVERSION DETAILS

The LTC1278 uses a successive approximation algorithm and an internal sample-and-hold circuit to convert an analog signal to a 12-bit parallel output. The ADC is complete with a precision reference and an internal clock. The control logic provides easy interface to microprocessors and DSPs. (Please refer to the Digital Interface section for the data format.)

Conversion start is controlled by the  $\overline{CS}$  and  $\overline{CONVST}$  inputs. At the start of conversion the successive approximation register (SAR) is reset. Once a conversion cycle has begun it cannot be restarted.

During conversion, the internal 12-bit capacitive DAC output is sequenced by the SAR from the most significant bit (MSB) to the least significant bit (LSB). Referring to Figure 1, the  $A_{IN}$  input connects to the sample-and-hold capacitor during the acquire phase, and the comparator

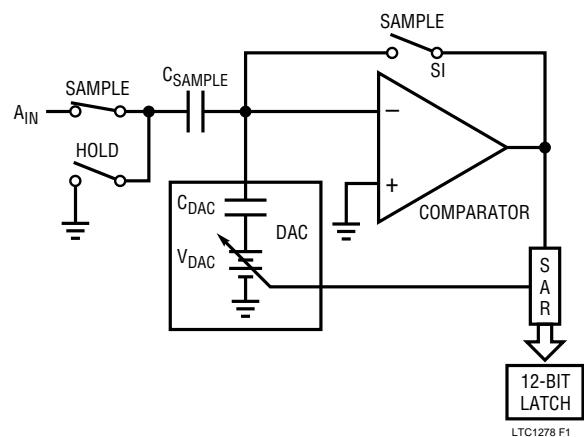

Figure 1.  $A_{IN}$  Input

offset is nulled by the feedback switch. In this acquire phase, a minimum delay of 200ns will provide enough time for the sample-and-hold capacitor to acquire the analog signal. During the convert phase, the comparator feedback switch opens, putting the comparator into the



## APPLICATIONS INFORMATION

compare mode. The input switch switches  $C_{SAMPLE}$  to ground, injecting the analog input charge onto the summing junction. This input charge is successively compared with the binary-weighted charges supplied by the capacitive DAC. Bit decisions are made by the high speed comparator. At the end of a conversion, the DAC output balances the  $A_{IN}$  input charge. The SAR contents (a 12-bit data word) which represent the  $A_{IN}$  are loaded into the 12-bit output latches.

### DYNAMIC PERFORMANCE

The LTC1278 has excellent high speed sampling capability. FFT (Fast Fourier Transform) test techniques are used to test the ADC's frequency response, distortion and noise at the rated throughput. By applying a low distortion sine wave and analyzing the digital output using an FFT algorithm, the ADC's spectral content can be examined for frequencies outside the fundamental. Figure 2 shows a typical LTC1278 FFT plot.

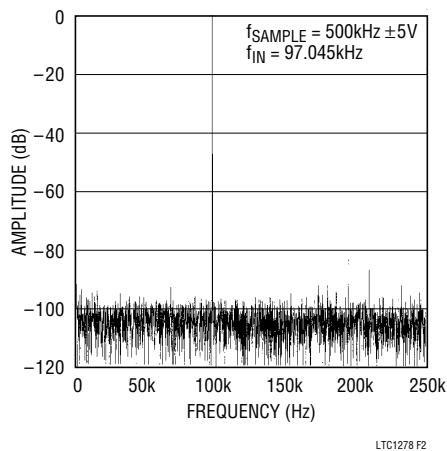

Figure 2. LTC1278 Nonaveraged, 4096 Point FFT Plot

### Signal-to-Noise Ratio

The Signal-to-Noise plus Distortion Ratio  $[S/(N + D)]$  is the ratio between the RMS amplitude of the fundamental input frequency to the RMS amplitude of all other frequency components at the A/D output. The output is band limited to frequencies from above DC and below half the sampling frequency. Figure 2 shows a typical spectral content with

a 500kHz sampling rate and a 100kHz input. The dynamic performance is excellent for input frequencies up to the Nyquist limit of 250kHz.

### Effective Number of Bits

The Effective Number of Bits (ENOBs) is a measurement of the resolution of an ADC and is directly related to the  $S/(N + D)$  by the equation:

$$N = [S/(N + D) - 1.76]/6.02$$

where N is the Effective Number of Bits of resolution and  $S/(N + D)$  is expressed in dB. At the maximum sampling rate of 500kHz the LTC1278 maintains very good ENOBs up to the Nyquist input frequency of 250kHz. Refer to Figure 3.

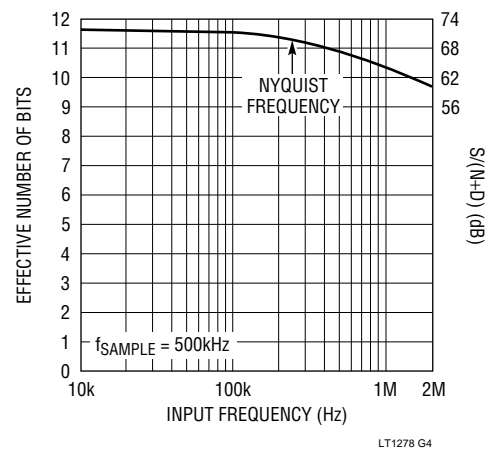

Figure 3. Effective Bits and Signal-to-Noise + Distortion vs Input Frequency

### Total Harmonic Distortion

Total Harmonic Distortion (THD) is the ratio of the RMS sum of all harmonics of the input signal to the fundamental itself. The out-of-band harmonics alias into the frequency band between DC and half the sampling frequency. THD is expressed as:

$$THD = 20 \log \frac{\sqrt{V_2^2 + V_3^2 + V_4^2 \dots + V_N^2}}{V_1}$$

where  $V_1$  is the RMS amplitude of the fundamental frequency and  $V_2$  through  $V_N$  are the amplitudes of the second through Nth harmonics. THD versus input

## APPLICATIONS INFORMATION

frequency is shown in Figure 4. The LTC1278 has good distortion performance up to the Nyquist frequency and beyond.

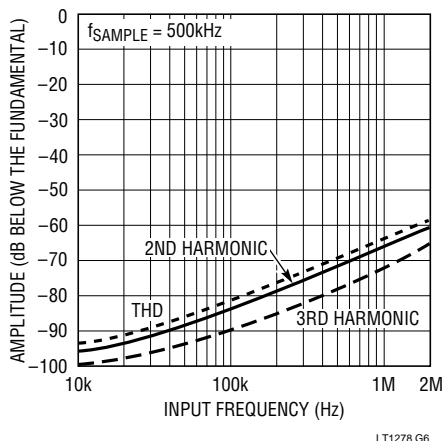

Figure 4. Distortion vs Input Frequency

### Intermodulation Distortion

If the ADC input signal consists of more than one spectral component, the ADC transfer function nonlinearity can produce intermodulation distortion (IMD) in addition to THD. IMD is the change in one sinusoidal input caused by the presence of another sinusoidal input at a different frequency.

If two pure sine waves of frequencies  $f_a$  and  $f_b$  are applied to the ADC input, nonlinearities in the ADC transfer function can create distortion products at sum and difference frequencies of  $m f_a \pm n f_b$ , where  $m$  and  $n = 0, 1, 2, 3$ , etc. For example, the 2nd order IMD terms include  $(f_a + f_b)$  and  $(f_a - f_b)$  while the 3rd order IMD terms include  $(2f_a + f_b)$ ,  $(2f_a - f_b)$ ,  $(f_a + 2f_b)$ , and  $(f_a - 2f_b)$ . If the two input sine waves are equal in magnitude, the value (in decibels) of the 2nd order IMD products can be expressed by the following formula:

$$\text{IMD}(f_a \pm f_b) = 20 \log \frac{\text{Amplitude at } (f_a \pm f_b)}{\text{Amplitude at } f_a}$$

Figure 5 shows the IMD performance at a 100kHz input.

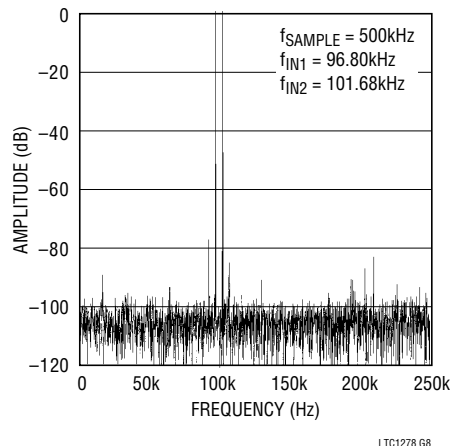

Figure 5. Intermodulation Distortion Plot

### Peak Harmonic or Spurious Noise

The peak harmonic or spurious noise is the largest spectral component excluding the input signal and DC. This value is expressed in decibels relative to the RMS value of a full scale input signal.

### Full Power and Full Linear Bandwidth

The full power bandwidth is that input frequency at which the amplitude of the reconstructed fundamental is reduced by 3dB for a full scale input signal.

The full linear bandwidth is the input frequency at which the  $S/(N + D)$  has dropped to 68dB (11 effective bits). The LTC1278 has been designed to optimize input bandwidth, allowing ADC to undersample input signals with frequencies above the converter's Nyquist Frequency. The noise floor stays very low at high frequencies;  $S/(N + D)$  becomes dominated by distortion at frequencies far beyond Nyquist.

### Driving the Analog Input

The analog input of the LTC1278 is easy to drive. It draws only one small current spike while charging the sample-and-hold capacitor at the end of conversion. During conversion the analog input draws no current. The only requirement is that the amplifier driving the analog input must settle after the small current spike before the next

## APPLICATIONS INFORMATION

conversion starts. Any op amp that settles in 200ns to small current transients will allow maximum speed operation. If slower op amps are used, more settling time can be provided by increasing the time between conversions. Suitable devices capable of driving the ADC's  $A_{IN}$  input include the LT1360, LT1220, LT1223 and LT1224 op amps.

### Internal Reference

The LTC1278 has an on-chip, temperature compensated, curvature corrected, bandgap reference, which is factory trimmed to 2.42V. It is internally connected to the DAC and is available at pin 2 to provide up to 1mA current to an external load.

For minimum code transition noise the reference output should be decoupled with a capacitor to filter wideband noise from the reference (10 $\mu$ F tantalum in parallel with a 0.1 $\mu$ F ceramic).

The  $V_{REF}$  pin can be driven with a DAC or other means to provide input span adjustment in bipolar mode. The  $V_{REF}$  pin must be driven to at least 2.45V to prevent conflict with the internal reference. The reference should be driven to no more than 4.8V to keep the input span within the  $\pm 5V$  supplies.

Figure 6 shows an LT1006 op amp driving the reference pin. (In the unipolar mode, the input span is already 0V to 5V with the internal reference so driving the reference is not recommended, since the input span will exceed the supply and codes will be lost at the full scale.) Figure 7 shows a typical reference, the LT1019A-2.5 connected to the LTC1278. This will provide an improved drift (equal to the maximum 5ppm/ $^{\circ}$ C of the LT1019A-2.5) and a  $\pm 2.582V$  full scale.

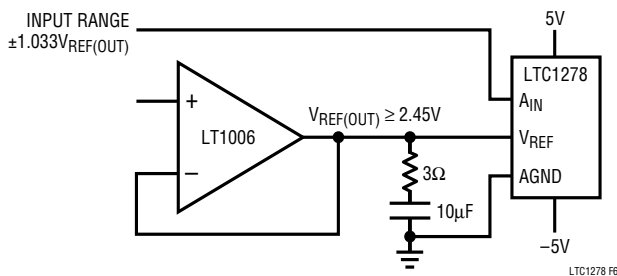

Figure 6. Driving the  $V_{REF}$  with the LT1006 Op Amp

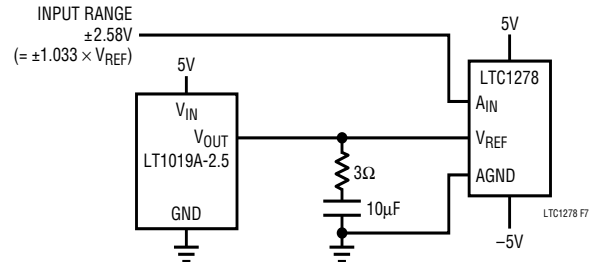

Figure 7. Supplying a 2.5V Reference Voltage to the LTC1278 with the LT1019A-2.5

### UNIPOLAR/BIPOLAR OPERATION AND ADJUSTMENT

Figure 8a shows the ideal input/output characteristics for the LTC1278. The code transitions occur midway between successive integer LSB values (i.e., 1/2LSB, 1 1/2LSB, 2 1/2LSB, ... FS – 1 1/2 LSB). The output code is naturally binary with 1LSB = FS/4096 = 5V/4096 = 1.22mV. Figure 8b shows the input/output transfer characteristics for the bipolar mode in two's complement format.

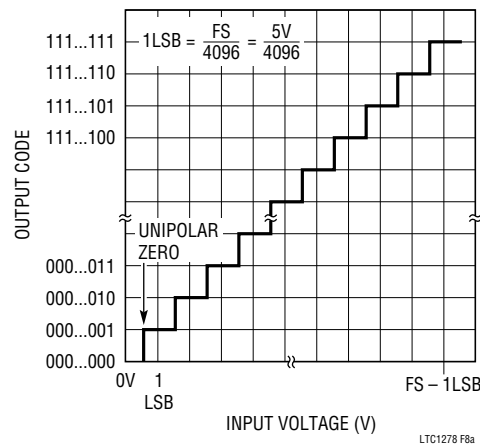

Figure 8a. LTC1278 Unipolar Transfer Characteristics

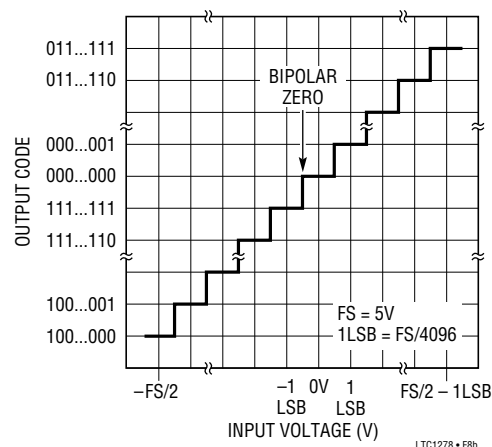

Figure 8b. LTC1278 Bipolar Transfer Characteristics

## APPLICATIONS INFORMATION

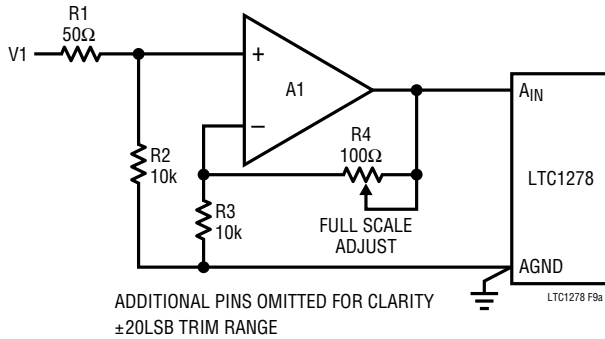

Figure 9a. Full Scale Adjust Circuit

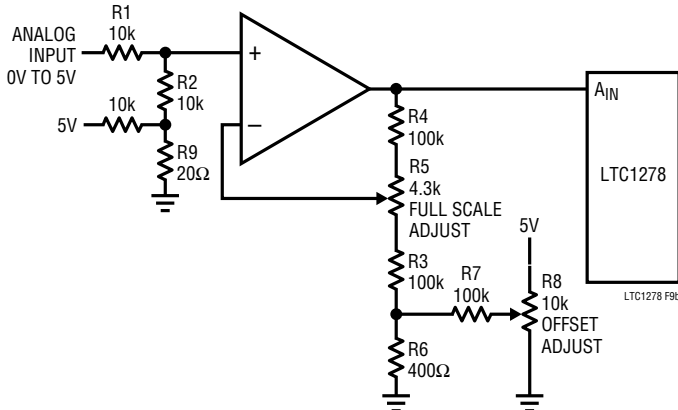

Figure 9b. LTC1278 Unipolar Offset and Full Scale Adjust Circuit

## Unipolar Offset and Full Scale Error Adjustments

In applications where absolute accuracy is important, then offset and full scale errors can be adjusted to zero. Offset error must be adjusted before full scale error. Figure 9a shows the extra components required for full scale error adjustment. If both offset and full scale adjustments are needed, the circuit in Figure 9b can be used. For zero offset error apply 0.61 mV (i.e., 1/2LSB) at the input and adjust the offset trim until the LTC1278 output code flickers between 0000 0000 0000 and 0000 0000 0001. For zero full scale error apply an analog input of 4.99817V (i.e., FS – 1 1/2LSB or last code transition) at the input and adjust R5 until the LTC1278 output code flickers between 1111 1111 1110 and 1111 1111 1111.

## Bipolar Offset and Full Scale Error Adjustments

Bipolar offset and full scale errors are adjusted in a similar fashion to the unipolar case. Again, bipolar offset must be adjusted before full scale error. Bipolar offset error adjustment is achieved by trimming the offset of the op amp

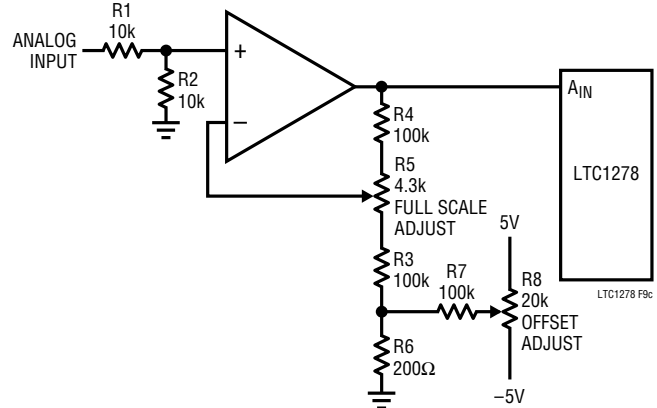

Figure 9c. LTC1278 Bipolar Offset and Full Scale Adjust Circuit

driving the analog input of the LTC1278 while the input voltage is 1/2LSB below ground. This is done by applying an input voltage of  $-0.61\text{mV}$  ( $-1/2\text{LSB}$ ) to the input in Figure 9c and adjusting the R8 until the ADC output code flickers between 0000 0000 0000 and 1111 1111 1111. For full scale adjustment, an input voltage of 2.49817V ( $\text{FS} - 3/2\text{LSBs}$ ) is applied to the input and R5 is adjusted until the output code flickers between 0111 1111 1110 and 0111 1111 1111.

## BOARD LAYOUT AND BYPASSING

Wire wrap boards are not recommended for high resolution or high speed A/D converters. To obtain the best performance from the LTC1278, a printed circuit board is required. Layout for the printed circuit board should ensure that digital and analog signal lines are separated as much as possible. In particular, care should be taken not to run any digital track alongside an analog signal track or underneath the ADC. The analog input should be screened by AGND.

High quality tantalum and ceramic bypass capacitors should be used at the  $\text{AV}_{\text{DD}}$  and  $\text{V}_{\text{REF}}$  pins as shown in Figure 10. For the bipolar mode, a  $0.1\mu\text{F}$  ceramic provides adequate bypassing for the  $\text{V}_{\text{SS}}$  pin. The capacitors must be located as close to the pins as possible. The traces connecting the pins and the bypass capacitors must be kept short and should be made as wide as possible.

Input signal leads to  $\text{A}_{\text{IN}}$  and signal return leads from AGND (pin 3) should be kept as short as possible to minimize input noise coupling. In applications where this is not possible, a shielded cable between source and ADC is recommended.

## APPLICATIONS INFORMATION

Also, since any potential difference in grounds between the signal source and ADC appears as an error voltage in series with the input signal, attention should be paid to reducing the ground circuit impedances as much as possible.

A single point analog ground separate from the logic system ground should be established with an analog ground plane at pin 3 (AGND) or as close as possible to the ADC. Pin 12 (DGND) and all other analog grounds should be connected to this single analog ground point. No other digital grounds should be connected to this analog ground point. Low impedance analog and digital power supply common returns are essential to low noise operation of the ADC and the foil width for these tracks should be as wide as possible. In applications where the ADC data outputs and control signals are connected to a continuously active microprocessor bus, it is possible to get errors in conversion results. These errors are due to feedthrough from the microprocessor to the successive approximation comparator. The problem can be eliminated by forcing the microprocessor into a WAIT state during conversion or by using three-state buffers to isolate the ADC data bus.

## DIGITAL INTERFACE

The A/D converter is designed to interface with microprocessors as a memory mapped device. The  $\overline{CS}$  and  $\overline{RD}$  control inputs are common to all peripheral memory interfacing. A separate  $\overline{CONVST}$  is used to initiate a conversion.

## Internal Clock

The A/D converter has an internal clock that eliminates the need of synchronization between the external clock and the  $\overline{CS}$  and  $\overline{RD}$  signals found in other ADCs. The internal clock is factory trimmed to achieve a typical conversion time of 1.6 $\mu$ s. No external adjustments are required, and with the typical acquisition time of 250ns, throughput performance of 500ksps is assured.

## Power Shutdown

The LTC1278 provides a shutdown feature that will save power when the ADC is in inactive periods. To power down the ADC, pin 18 (SHDN) needs to be driven low. When in power shutdown mode, the LTC1278 will not start a conversion even though the  $\overline{CONVST}$  goes low. All the

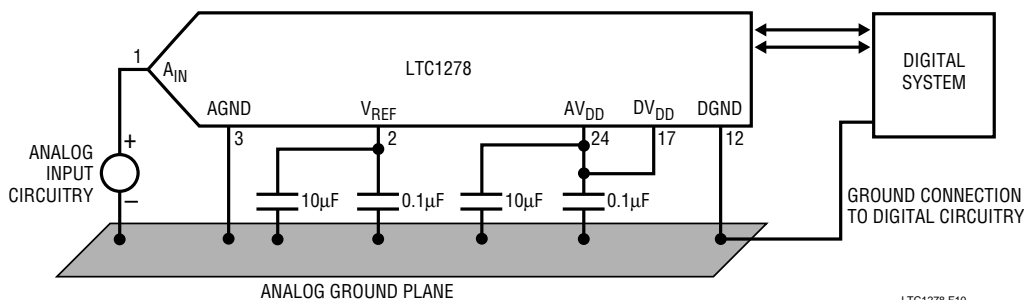

Figure 10. Power Supply Grounding Practice

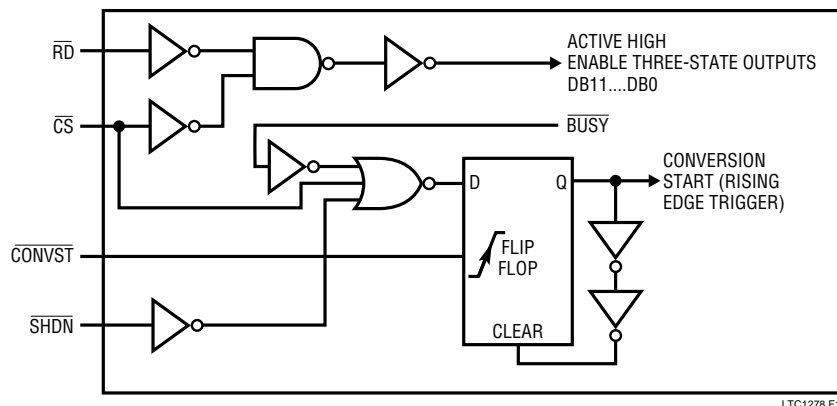

Figure 11. Internal Logic for Control Inputs  $\overline{CS}$ ,  $\overline{RD}$ ,  $\overline{CONVST}$  and  $\overline{SHDN}$

## APPLICATIONS INFORMATION

power is off except the Internal Reference which is still active and provides 2.42V output voltage to the other circuitry. In this mode the ADC draws 8.5mW instead of 75mW (for minimum power, the logic inputs must be within 600mV of the supply rails). The wake-up time from the power shutdown to active state is 350ns.

### Timing and Control

Conversion start and data read operations are controlled by three digital inputs:  $\overline{CS}$ ,  $\overline{CONVST}$  and  $\overline{RD}$ . Figure 11 shows the logic structure associated with these inputs. A logic “0” for  $\overline{CONVST}$  will start a conversion after the ADC has been selected (i.e.,  $\overline{CS}$  is low). Once initiated it cannot be restarted until the conversion is complete. Converter status is indicated by the  $\overline{BUSY}$  output, and this is low while conversion is in progress.

Figures 12 through 16 show several different modes of operation. In modes 1a and 1b (Figures 12 and 13)  $\overline{CS}$  and  $\overline{RD}$  are both tied low. The falling  $\overline{CONVST}$  starts the conversion. The data outputs are always enabled and data can be latched with the  $\overline{BUSY}$  rising edge. Mode 1a shows operation with a narrow low going  $\overline{CONVST}$  pulse. Mode 1b shows high going  $\overline{CONVST}$  pulse.

In mode 2 (Figure 14)  $\overline{CS}$  is tied low. The falling  $\overline{CONVST}$  signal again starts the conversion. Data outputs are in three-state until read by MPU with the  $\overline{RD}$  signal. Mode 2 can be used for operation with a shared MPU databus.

In Slow memory and ROM modes (Figures 15 and 16)  $\overline{CS}$  is tied low and  $\overline{CONVST}$  and  $\overline{RD}$  are tied together. The MPU starts conversion and read the output with the  $\overline{RD}$  signal. Conversions are started by the MPU or DSP (no external sample clock).

In Slow memory mode the processor takes  $\overline{RD}$  (=  $\overline{CONVST}$ ) low and starts the conversion.  $\overline{BUSY}$  goes low forcing the processor into a WAIT state. The previous conversion result appears on the data outputs. When the conversion is complete, the new conversion results appear on the data outputs;  $\overline{BUSY}$  goes high releasing the processor, and the processor takes  $\overline{RD}$  (=  $\overline{CONVST}$ ) back high and reads the new conversion data.

In ROM mode, the processor takes  $\overline{RD}$  (=  $\overline{CONVST}$ ) low which starts a conversion and reads the previous conversion result. After the conversion is complete, the processor can read the new result (which will initiate another conversion).

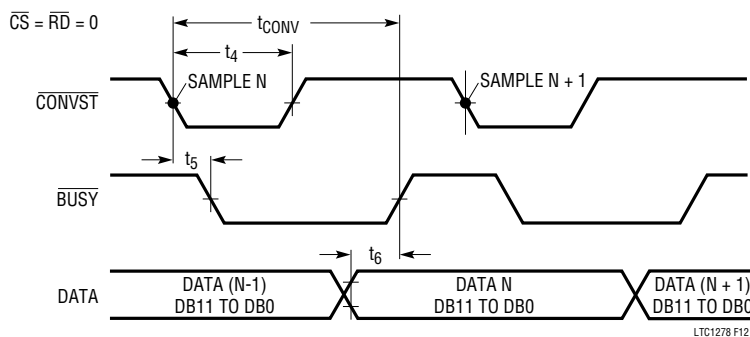

Figure 12. Mode 1a.  $\overline{CONVST}$  Starts a Conversion. Data Outputs Always Enabled. ( $\overline{CONVST}$  = )

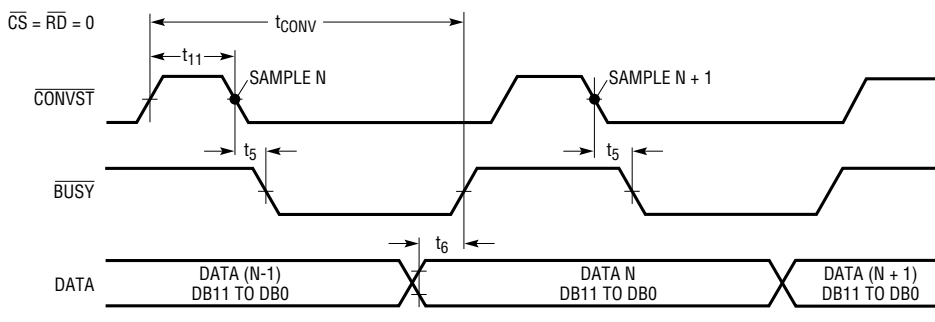
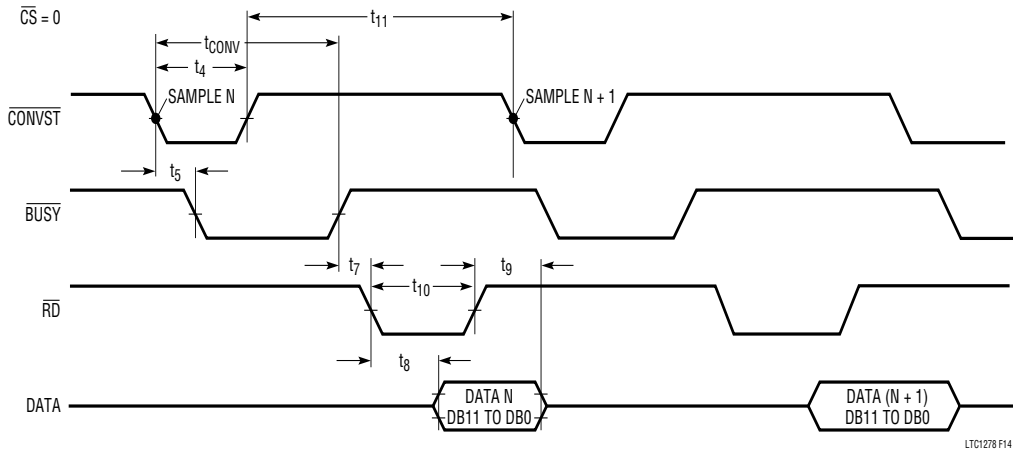

Figure 13. Mode 1b.  $\overline{CONVST}$  Starts a Conversion. Data Outputs Always Enabled. ( $\overline{CONVST}$  = )

# APPLICATIONS INFORMATION



LTC1278 F14

Figure 14. Mode 2.  $\overline{CONVST}$  Starts a Conversion. Data is Read by  $\overline{RD}$

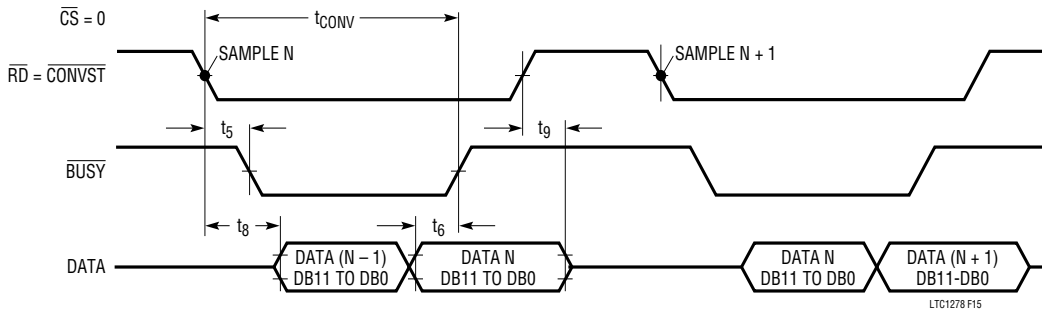

LTC1278 F15

Figure 15. Slow Memory Mode

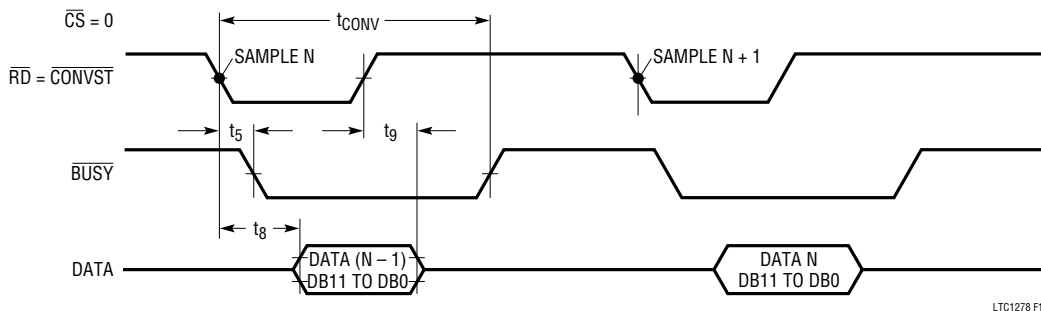

LTC1278 F16

Figure 16. ROM Mode Timing

**PACKAGE DESCRIPTION** Dimensions in inches (millimeters) unless otherwise noted.

**N Package  
24-Lead Plastic DIP**

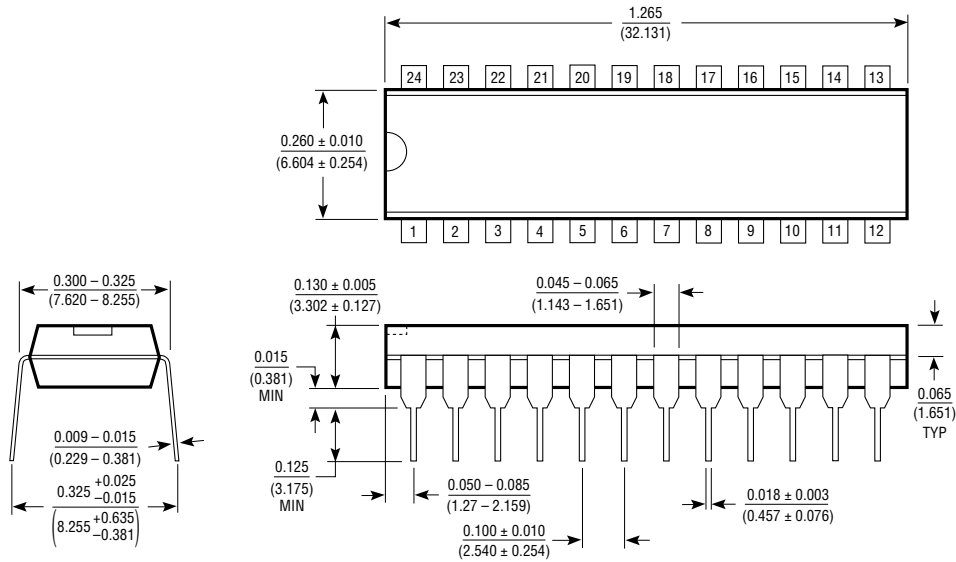

**S Package  
24-Lead Plastic SOL**

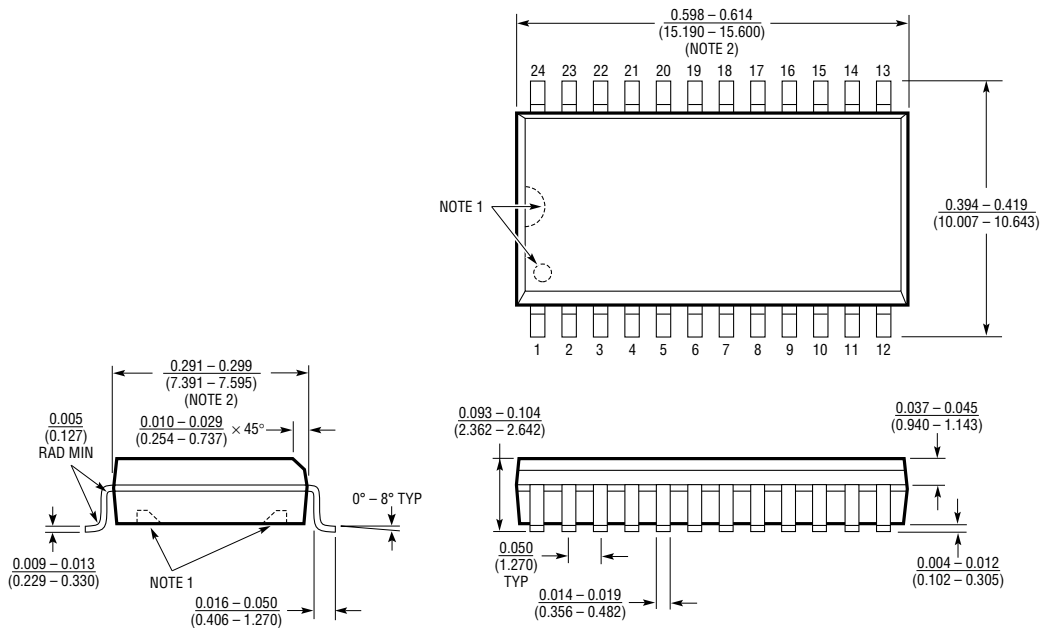

- NOTE:  
 1. PIN 1 IDENT, NOTCH ON TOP AND CAVITIES ON THE BOTTOM OF PACKAGES ARE THE MANUFACTURING OPTIONS. THE PART MAY BE SUPPLIED WITH OR WITHOUT ANY OF THE OPTIONS.  
 2. THESE DIMENSIONS DO NOT INCLUDE MOLD FLASH OR PROTRUSIONS. MOLD FLASH OR PROTRUSIONS SHALL NOT EXCEED 0.006 INCH (0.15mm).