

MAXIM

Quad SPST CMOS Analog Switches

General Description

The DG201A and DG211 are normally closed, quad single-pole single-throw (SPST) analog switches. These CMOS switches can be continuously operated with power supplies ranging from $\pm 4.5\text{V}$ to $\pm 18\text{V}$. Maxim guarantees that these switches will not latch up if the power supplies are disconnected with input signals still connected.

Both devices have guaranteed break-before-make switching. The DG201A differs from the DG211 primarily in switching speeds. The DG201A has a maximum turn-off time of 450ns and a maximum turn-on time of 600ns. The DG211 has a maximum turn-off time of 500ns and a maximum turn-on time of 1000ns.

Compared to the original manufacturer's products, Maxim's DG201A and DG211 consume significantly lower power making them better suited for portable applications. Maxim has also eliminated the need for the third (V_L) power supply that is required for the operation of the original manufacturer's DG211.

Applications

- Winchester Disk Drives
- Test Equipment
- Communications Systems
- PBX, PABX
- Guidance and Control Systems
- Head Up Displays
- Military Radios

Pin Configurations continued at end of data sheet.

Typical Operating Circuit

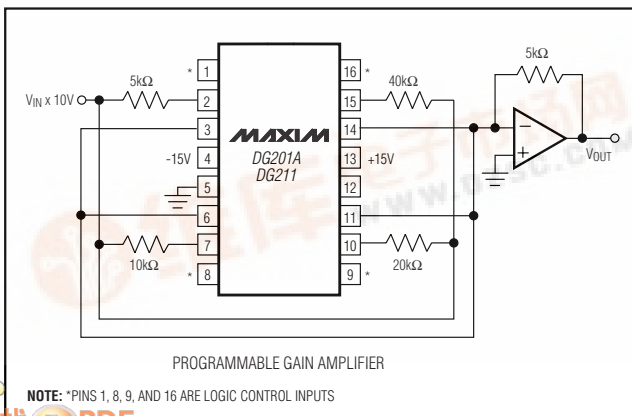

Features

- ◆ Guaranteed $\pm 4.5\text{V}$ to $\pm 18\text{V}$ Operation
- ◆ No V_L Supply Required
- ◆ Nonlatching with Supplies Turned Off and Input Signals Present
- ◆ CMOS and TTL Logic Compatible
- ◆ Monolithic, Low-Power CMOS Design

Ordering Information

PART	TEMP. RANGE	PIN-PACKAGE
DG201ACUE	0°C to +70°C	16 TSSOP
DG201ACSE	0°C to +70°C	16 SO
DG201ACJ	0°C to +70°C	16 Plastic DIP
DG201C/D	0°C to +70°C	Dice
DG201AEGE	-40°C to +85°C	16 QFN (5 × 5)
DG201AEUE	-40°C to +85°C	16 TSSOP
DG201ADY	-40°C to +85°C	16 SO
DG201ADJ	-40°C to +85°C	16 Plastic DIP
DG201AAK	-55°C to +125°C	16 CERDIP
DG211CUE	0°C to +70°C	16 TSSOP
DG211CSE	0°C to +70°C	16 SO
DG211CJ	0°C to +70°C	16 Plastic DIP
DG211C/D	0°C to +70°C	Dice
DG211EGE	-40°C to +85°C	16 QFN (5 × 5)
DG211EUE	-40°C to +85°C	16 TSSOP
DG211DY	-40°C to +85°C	16 SO
DG211DJ	-40°C to +85°C	16 Plastic DIP

Pin Configurations

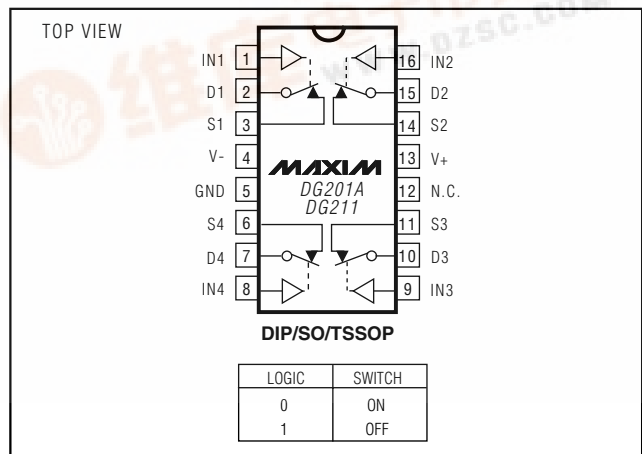

DG201A/DG211

Quad SPST CMOS Analog Switches

ABSOLUTE MAXIMUM RATINGS (DG211)

V+ to V-	44V
V _{IN} to Ground	V-, V+
V _L to Ground	-0.3V, 25V
V _S or V _D to V+	0, -40V
V _S or V _D to V-	0, 40V
V+ to Ground	25V
V- to Ground	-25V
Current, Any Terminal Except S or D	30mA
Continuous Current, S or D	20mA
Peak Current, S or D (pulsed at 1ms 10% duty cycle max)	70mA

Storage Temperature Range	-65°C to +125°C
Operating Temperature Range	
DG211C	0°C to +70°C
DG211D/E	-40°C to +85°C
Power Dissipation (T _A = +70°C) (Note 1)	
16-Pin Plastic Dip (derate 10.5mW/°C above +70°C)	842mW
16-Pin Narrow SO (derate 8.3mW/°C above +70°C)	696mW
16-Pin TSSOP (derate 9.4mW/°C above +70°C)	755mW
16-Pin QFN (5 × 5) (derate 19.2mW/°C above +70°C)	1538mW

Note 1: Device mounted with all leads soldered to PC board.

Stresses beyond those listed under "Absolute Maximum Ratings" may cause permanent damage to the device. These are stress ratings only, and functional operation of the device at these or any other conditions beyond those indicated in the operational sections of the specifications is not implied. Exposure to absolute maximum rating conditions for extended periods may affect device reliability.

ELECTRICAL CHARACTERISTICS (DG211)

(V+ = +15V, V- = -15V, GND = 0, T_A = +25°C, unless otherwise noted.) (For more information on TYP values see Note 2.)

PARAMETER	SYMBOL	CONDITIONS	MIN	TYP	MAX	UNITS
SWITCH						
Analog Signal Range	V _{ANALOG}		-15		15	V
Drain-Source ON-Resistance	R _{DS (ON)}	V _D = ±10V, V _{IN} = 0.8V, I _S = 1mA		115	175	Ω
Source OFF-Leakage Current	I _{S (OFF)}	V _{IN} = 2.4V V _S = 14V, V _D = -14V V _S = -14V, V _D = 14V		0.01 -5.0	5.0	nA
Drain OFF-Leakage Current	I _{D (OFF)}	V _{IN} = 2.4V V _S = 14V, V _D = -14V V _S = -14V, V _D = 14V		0.01 -5.0	5.0	
Drain ON-Leakage Current (Note 3)	I _{D (ON)}	V _{IN} = 0.8V V _S = V _D = 14V V _S = V _D = -14V		0.1 -5.0	5.0	
INPUT						
Input Current with Input Voltage High	I _{INH}	V _{IN} = 2.4V V _{IN} = 15V	-1.0	-0.0004 0.003	1.0	μA
Input Current with Input Voltage Low	I _{INL}	V _{IN} = 0	-1.0	-0.0004		
DYNAMIC						
Turn-ON Time	t _{ON}	See Figure 1 Switching Time Test Circuit		460	1000	ns
Turn-OFF Time	t _{OFF1}	V _S = 2V, R _L = 1kΩ, C _L = 35pF		360	500	
	t _{OFF2}			450		
Source OFF-Capacitance	C _{S (OFF)}	V _S = 0, V _{IN} = 5V, f = 1MHz		5		pF
Drain OFF-Capacitance	C _{D (OFF)}	V _D = 0, V _{IN} = 5V, f = 1MHz		5		
Channel ON-Capacitance	C _{D + S (ON)}	V _D = V _S = 0, V _{IN} = 0, f = 1MHz		16		
OFF-Isolation (Note 4)	OIRR	V _{IN} = 5V, R _L = 1kΩ, C _L = 15pF, V _S = 1VRMS, f = 100kHz		70		
Crosstalk (Channel to Channel)	CCRR			90		dB

Quad SPST CMOS Analog Switches

DG201A/DG211

ELECTRICAL CHARACTERISTICS (DG211) (continued)

(V₊ = +15V, V₋ = -15V, GND = 0, T_A = +25°C, unless otherwise noted.) (For more information on TYP values see Note 2.)

PARAMETER	SYMBOL	CONDITIONS	MIN	TYP	MAX	UNITS
SUPPLY						
Positive Supply Current	I ⁺	V _{IN} = 0 and 2.4V (all)		0.02	0.4	mA
Negative Supply Current	I ⁻		0.01	0.4		
Logic Supply Current	I _L		0	0		
Power-Supply Range for Continuous Operation	V _{OP}		±4.5		±18	V

Note 2: Typical values are for DESIGN AID ONLY, not guaranteed nor subject to production testing.

Note 3: I_{D(ON)} is leakage from driver into "ON" switch.

Note 4: OFF-Isolation = 20 log V_S/V_D, V_S = input to OFF switch, V_D = output.

ABSOLUTE MAXIMUM RATINGS (DG201A)

Voltages Reference to V₋

V₊.....44V

GND.....25V

Digital Inputs (Note 1), V_S, V_D.....-2V to (V₊ + 2V)
or 20mA, whichever occurs first

Current, Any Terminal Except S or D.....30mA

Continuous Current, S or D.....20mA

Peak Current, S or D
(pulsed at 1ms 10% duty cycle max).....70mA

Operating Temperature Range

DG201AA.....-55°C to +125°C

DG201AD/E-40°C to +85°C

DG201AC0°C to +70°C

Storage Temperature Range.....-65°C to +150°C

Power Dissipation (Note 2)

16-Pin Plastic Dip (derate 10.5mW/°C above +70°C) ..842mW

16-Pin SO (derate 8.7mW/°C above +70°C)696mW

16-Pin TSSOP (derate 9.4mW/°C above +70°C).....755mW

16-Pin QFN (5 × 5)

(derate 19.2mW/°C above +70°C).....1538mW

16-Pin CERDIP (derate 10.0mW/°C above +70°C).....800mW

Note 1: Signals on S_i, D_i, or IN_i exceeding V₊ or V₋ on Maxim's DG201A will be clamped by internal diodes, and are also internally current limited to 25mA.

Note 2: Device mounted with all leads soldered to PC board.

Stresses beyond those listed under "Absolute Maximum Ratings" may cause permanent damage to the device. These are stress ratings only, and functional operation of the device at these or any other conditions beyond those indicated in the operational sections of the specifications is not implied. Exposure to absolute maximum rating conditions for extended periods may affect device reliability.

ELECTRICAL CHARACTERISTICS (DG201A)

(V₊ = +15V, V₋ = -15V, GND = 0, T_A = +25°C, unless otherwise noted.) (For more information on TYP values see Note 3.)

PARAMETER	SYMBOL	CONDITIONS	DG201AA			DG201AC, D, E			UNITS
			MIN	TYP	MAX	MIN	TYP	MAX	
SWITCH									
Analog Signal Range	V _{ANALOG}		-15		15	-15		15	V
Drain-Source ON Resistance	R _{DS(ON)}	V _D = ±10V, V _{IN} = 0.8V, I _S = 1mA		115	175		115	200	Ω
Source OFF-Leakage Current	I _{S(OFF)}	V _{IN} = 2.4V	V _S = 14V, V _D = -14V	0.01	1.0		0.01	5.0	nA
			V _S = -14V, V _D = 14V	-1.0	-0.02		-5.0	-0.02	
Drain OFF-Leakage Current	I _{D(OFF)}	V _{IN} = 2.4V	V _S = 14V, V _D = -14V	0.01	1.0		0.01	5.0	
			V _S = -14V, V _D = 14V	-1.0	-0.02		-5.0	-0.02	
Drain ON-Leakage Current (Note 4)	I _{D(ON)}	V _{IN} = 0.8V	V _S = -14V	0.1	1.0		0.1	1.0	
			V _S = 14V	-1.0			-1.0		

Quad SPST CMOS Analog Switches

ELECTRICAL CHARACTERISTICS (DG201A) (continued)

(V+ = +15V, V- = -15V, GND = 0, TA = +25°C, unless otherwise noted.) (For more information on TYP values see Note 3.)

PARAMETER	SYMBOL	CONDITIONS	DG201AA			DG201AC, D, E			UNITS
			MIN	TYP	MAX	MIN	TYP	MAX	
INPUT									
Input Current with Input Voltage High	I _{INH}	V _{IN} = 2.4V	-1.0			-1.0			μA
		V _{IN} = 15V			1.0			1.0	
Input Current with Input Voltage Low	I _{INL}	V _{IN} = 0+	-1.0			-1.0			
DYNAMIC									
Turn-ON Time	t _{ON}	See Figure 1 Switching Time Test Circuit	480	600		480	600		ns
Turn-OFF Time	t _{OFF1}		370	450		370	450		
Charge Injection	Q	C _L = 1000pF, V _{GEN} = 0, R _{GEN} = 0	20			20			pC
Source OFF-Capacitance	C _S (OFF)	V _S = 0, V _{IN} = 5V f = 140kHz	5			5			pF
Drain OFF-Capacitance	C _D (OFF)		5			5			
Channel ON-Capacitance	C _D (ON) + C _S (ON)		V _D = V _S = 0, V _{IN} = 0	16			16		
OFF-Isolation		V _{IN} = 5V, Z _L = 75Ω	70			70			dB
Crosstalk (Channel to Channel)		V _S = 2.0V, f = 100kHz	90			90			
SUPPLY									
Positive Supply Current	I ⁺	All channels ON or OFF	0.02	0.1		0.02	0.1		mA
Negative Supply Current	I ⁻	All channels ON or OFF	-0.1	-0.01		-0.1	-0.01		
Power-Supply Range for Continuous Operation	V _{OP}		±4.5		±18	±4.5		±18	V

Note 3: Typical values are for DESIGN AID ONLY, not guaranteed nor subject to production testing.

Note 4: I_D (ON) is leakage from driver into "ON" switch.

Quad SPST CMOS Analog Switches

DG201A/DG211

ELECTRICAL CHARACTERISTICS (DG201A)

(V₊ = +15V, V₋ = -15V, GND = 0, T_A = full operating temperature range, unless otherwise noted.) (For more information on TYP values see Note 3.)

PARAMETER	SYMBOL	CONDITIONS	DG201AA			DG201AC, D, E			UNITS
			MIN	TYP	MAX	MIN	TYP	MAX	
SWITCH									
Analog Signal Range	V _{ANALOG}		-15		15	-15		15	V
Drain-Source ON Resistance (Note 5)	R _{DS (ON)}	V _D = ±10V, V _{IN} = 0.8V, I _S = 1mA			250			250	Ω
Source OFF Leakage Current	I _{S (OFF)}	V _{IN} = 2.4V	V _S = 14V, V _D = -14V		100	100		nA	
			V _S = -14V, V _D = 14V		-100	-100			
Drain OFF Leakage Current	I _{D (OFF)}	V _{IN} = 2.4V	V _S = 14V, V _D = -14V		100	100			
			V _S = -14V, V _D = 14V		-100	-100			
Drain ON Leakage Current (Note 6)	I _{D (ON)}	V _{IN} = 0.8V	V _S = -14V		200	200			
			V _D = 14V		-200	-200			
INPUT									
Input Current with Input Voltage High	I _{INH}	V _{IN} = 2.4V	-1.0		-1.0		μA		
		V _{IN} = 15V			1.0				
Input Current with Input Voltage Low	I _{INL}	V _{IN} = 0	-1.0		-1.0				

Note 5: Electrical characteristics, such as ON-Resistance, will change when power supplies other than ±15V, are used.

Note 6: I_{D (ON)} is leakage from driver into "ON" switch.

Pin Description

PIN		NAME	FUNCTION
DIP/SO/TSSOP	QFN		
1, 16, 9, 8	15, 14, 7, 6	IN1–IN4	Input
2, 15, 10, 7	16, 13, 8, 5	D1–D4	Analog Switch Drain Terminal
3, 14, 11, 6	1, 12, 9, 4	S1–S4	Analog Switch Source Terminal
4	2	V-	Negative-Supply Voltage Input
5	3	GND	Ground
12	10	N.C.	No Connection
13	11	V+	Positive-Supply Voltage Input—Connected to Substrate

Switching Time Test Circuit

Switch output waveform shown for V_S = constant with logic input waveform as shown. Note that V_S may be +ve or -ve as per switching times test circuit. V_O is the steady state output with switch on. Feedthrough via gate capacitance may result in spikes at leading and trailing edge of output waveform.

Quad SPST CMOS Analog Switches

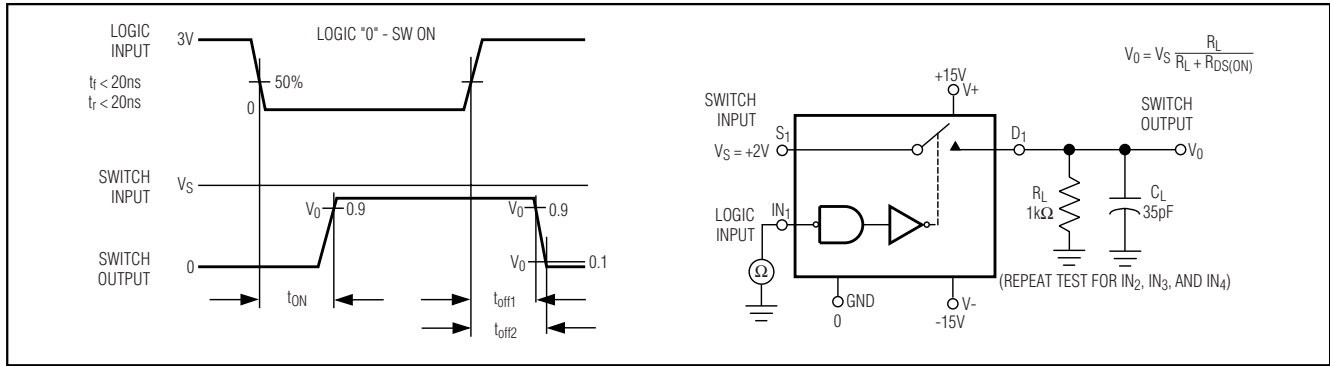

Figure 1. Switching Time

Typical $R_{DS(ON)}$ vs. Power Supplies for Maxim's DG201A, and DG211

POWER SUPPLIES	$R_{DS(ON)}$ AT ANALOG SIGNAL LEVEL					
	-5V	+5V	-10V	+10V	-15V	+15V
±5V	350Ω	380Ω	—	—	—	—
±10V	—	—	165Ω	250Ω	—	—
±15V	—	—	125Ω	160Ω	135Ω	155Ω

Protecting Against Fault Conditions

Fault conditions occur when power supplies are turned off when input signals are still present, or when overvoltages occur at the inputs during normal operation. In either case, source-to-body diodes can be forward biased and conduct current from the signal source. If this current is required to be kept to low (μA) levels then the addition of external protection diodes is recommended.

To provide protection for overvoltages up to 20V above the supplies, a 1N4001 or 1N914 type diode should be placed in series with the positive and negative supplies as shown in Figure 2. The addition of these diodes will reduce the analog signal range to 1V below the positive supply and 1V above the negative supply.

Pin Configurations (continued)

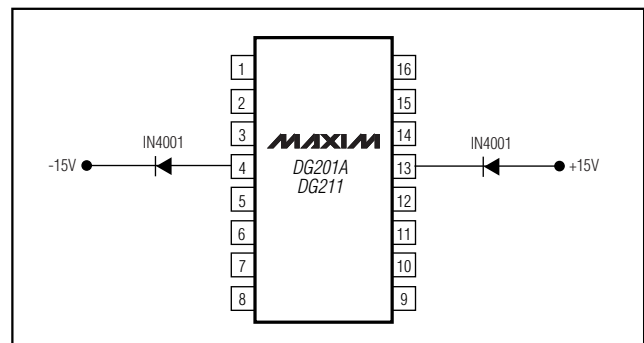
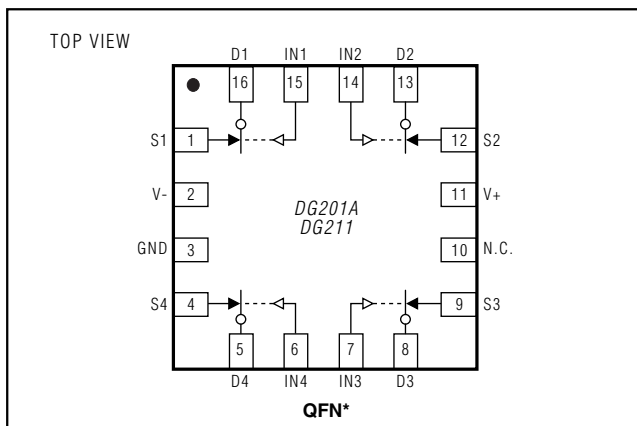
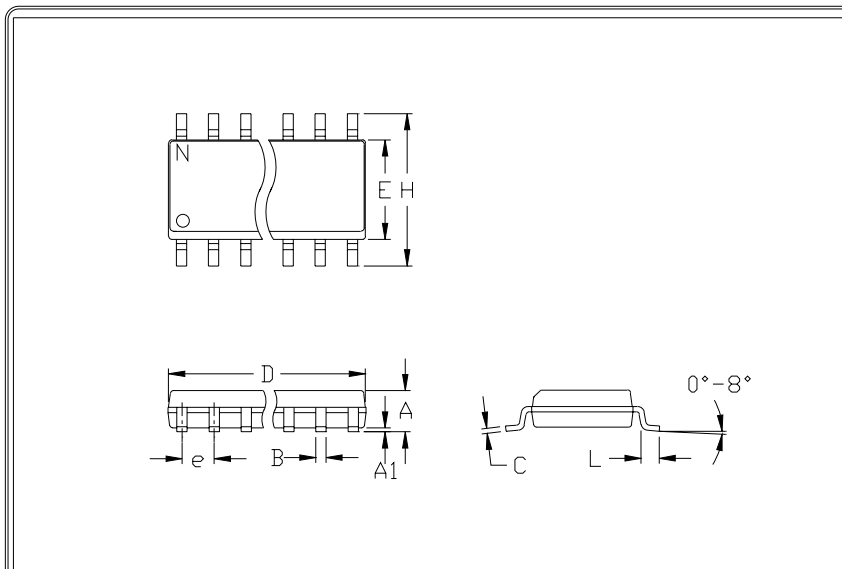

Figure 2. Protection against Fault Conditions

Quad SPST CMOS Analog Switches

Package Information

DG201A/DG211



	INCHES		MILLIMETERS	
	MIN	MAX	MIN	MAX
A	0.053	0.069	1.35	1.75
A1	0.004	0.010	0.10	0.25
B	0.014	0.019	0.35	0.49
C	0.007	0.010	0.19	0.25
e	0.050		1.27	
E	0.150	0.157	3.80	4.00
H	0.228	0.244	5.80	6.20
h	0.010	0.020	0.25	0.50
L	0.016	0.050	0.40	1.27

	INCHES		MILLIMETERS		N	MS012
	MIN	MAX	MIN	MAX		
D	0.189	0.197	4.80	5.00	8	A
D	0.337	0.344	8.55	8.75	14	B
D	0.386	0.394	9.80	10.00	16	C

- NOTES:
1. D&E DO NOT INCLUDE MOLD FLASH
 2. MOLD FLASH OR PROTRUSIONS NOT TO EXCEED .15mm (.006")
 3. LEADS TO BE COPLANAR WITHIN .102mm (.004")
 4. CONTROLLING DIMENSION: MILLIMETER
 5. MEETS JEDEC MS012-XX AS SHOWN IN ABOVE TABLE
 6. N = NUMBER OF PINS

MAXIM
120 SAN CARLOS ST. SAN CARLOS, CA 94060. FAX (415) 737-7704
PROPRIETARY INFORMATION

PACKAGE FAMILY OUTLINE: SOIC .150"

1/1

21-0041 A
DOCUMENT CONTROL NUMBER REV

Quad SPST CMOS Analog Switches

Package Information (continued)

PDIPN:EPS

	INCHES		MILLIMETERS			MS001
	MIN	MAX	MIN	MAX		
A	---	0.180	---	4.572	D	AB
A1	0.020	---	0.508	---	D	AC
A2	0.125	0.175	3.18	4.45	D	AA
A3	0.055	0.080	1.40	2.03	D	AD
B	0.015	0.021	0.381	0.533	D	AE
B1	0.045	0.060	1.14	1.524	D	AF
C	0.009	0.014	0.229	0.355	D	*5
D1	0.005	0.080	0.13	2.03		
E	0.300	0.325	7.62	8.255		
E1	0.275	0.295	6.985	7.493		
e	0.100	---	2.54	---		
eA	0.300	---	7.62	---		
eB	---	0.400	---	10.16		
L	0.115	0.150	2.921	3.81		

NOTES:

1. D&E DO NOT INCLUDE MOLD FLASH
2. MOLD FLASH OR PROTRUSIONS NOT TO EXCEED .15mm (.006")
3. CONTROLLING DIMENSION: MILLIMETER
4. MEETS JEDEC MS001-XX AS SHOWN IN ABOVE TABLE
5. SIMILAR TO JEDEC MS-095-AH
6. N = NUMBER OF PINS

630 SAN GABRIEL DR. SAN JOSE, CA 95086 FAX (408) 737-7154
PROPRIETARY INFORMATION

PACKAGE FAMILY OUTLINE: PDIP .300"

1/1

21-0043 B

DOCUMENT CONTROL NUMBER REV

Quad SPST CMOS Analog Switches

Package Information (continued)

DG201A/DG211

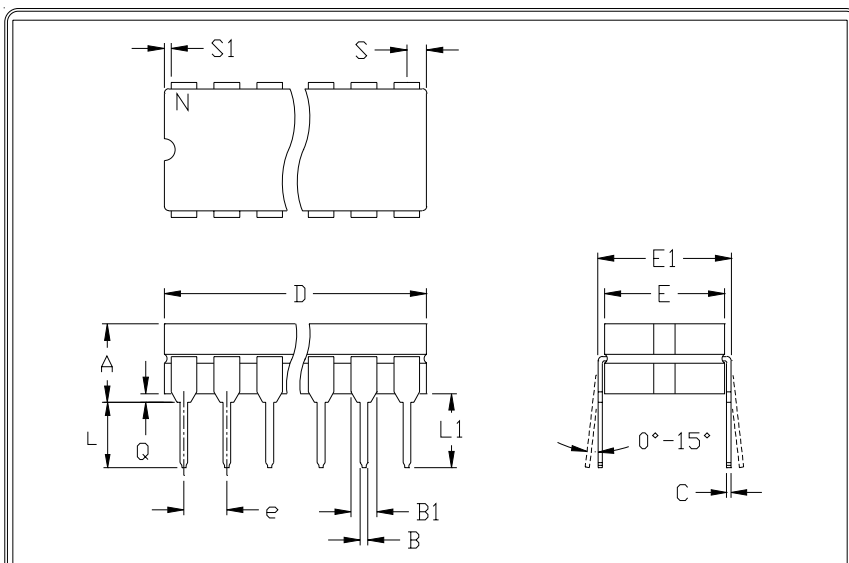

	INCHES		MILLIMETERS	
	MIN	MAX	MIN	MAX
A	---	0.200	---	5.08
B	0.014	0.023	0.36	0.58
B1	0.038	0.065	0.97	1.65
C	0.008	0.015	0.20	0.38
E	0.220	0.310	5.59	7.87
E1	0.290	0.320	7.37	8.13
e	0.100		2.54	
L	0.125	0.200	3.18	5.08
L1	0.150	---	0.00	---
Q	0.015	0.070	0.38	1.78
S	---	0.098	---	2.49
S1	0.005	---	0.13	---

	INCHES		MILLIMETERS		N	CASE
	MIN	MAX	MIN	MAX		
D	---	0.405	---	10.29	8	P:D4
D	---	0.785	---	19.94	14	C:D1
D	---	0.840	---	21.34	16	E:D2
D	---	0.960	---	24.38	18	V:D6
D	---	1.060	---	26.92	20	R:D8
D	---	1.280	---	32.51	24	L:D9

- NOTES:
 1. CONTROLLING DIMENSION: INCH
 2. MEETS 1835 CASE OUTLINE CONFIGURATION #1 AS SHOWN IN ABOVE TABLE
 3. N = NUMBER OF PINS

MAXIM
 120 SAN CARLOS DR. SAN JOSE, CA 94065. FAX (408) 737-7794
 PROPRIETARY INFORMATION

PACKAGE FAMILY OUTLINE: CDIP .300"
 TITLE

1/1

21-0045 A
 DOCUMENT CONTROL NUMBER REV

Quad SPST CMOS Analog Switches

Package Information (continued)

SYMBOL	COMMON DIMENSIONS			
	MILLIMETERS		INCHES	
	MIN.	MAX.	MIN.	MAX.
A	—	1.10	—	.043
A ₁	0.05	0.15	.002	.006
A ₂	0.85	0.95	.033	.037
b	0.19	0.30	.007	.012
b ₁	0.19	0.25	.007	.010
c	0.090	0.20	.0035	.008
c ₁	0.090	0.135	.0035	.0053
D	SEE VARIATIONS		SEE VARIATIONS	
E	4.30	4.50	.169	.177
e	.65 BSC		.026 BSC	
H	6.25	6.50	.246	.256
L	0.50	0.70	.020	.028
N	SEE VARIATIONS		SEE VARIATIONS	
α	0°	8°	0°	8°

JEDEC	N	VARIATIONS			
		MILLIMETERS		INCHES	
		MIN.	MAX.	MIN.	MAX.
AB-1	14	4.90	5.10	.193	.201
AB	16	4.90	5.10	.193	.201
AC	20	6.40	6.60	.252	.260
AD	24	7.70	7.90	.303	.311
AE	28	9.60	9.80	.378	.386

NOTES:

- DIMENSIONS D AND E DO NOT INCLUDE FLASH
- MOLD FLASH OR PROTRUSIONS NOT TO EXCEED 0.15mm PER SIDE
- CONTROLLING DIMENSION: MILLIMETER
- MEETS JEDEC OUTLINE MD-153. SEE JEDEC VARIATIONS TABLE.
- *N* REFERS TO NUMBER OF LEADS
- THE LEAD TIPS MUST LIE WITHIN A SPECIFIED ZONE. THIS TOLERANCE ZONE IS DEFINED BY TWO PARALLEL PLANES. ONE PLANE IS THE SEATING PLANE, DATUM [-C-]; THE OTHER PLANE IS AT THE SPECIFIED DISTANCE FROM [-C-] IN THE DIRECTION INDICATED.

PROPRIETARY INFORMATION

TITLE: PACKAGE OUTLINE, TSSOP, 4.40 MM BODY

APPROVAL	DOCUMENT CONTROL NO.	REV
	21-0066	E 1/1

TSSOP, NO PADS, EPS

Quad SPST CMOS Analog Switches

Package Information (continued)

DG201A/DG211

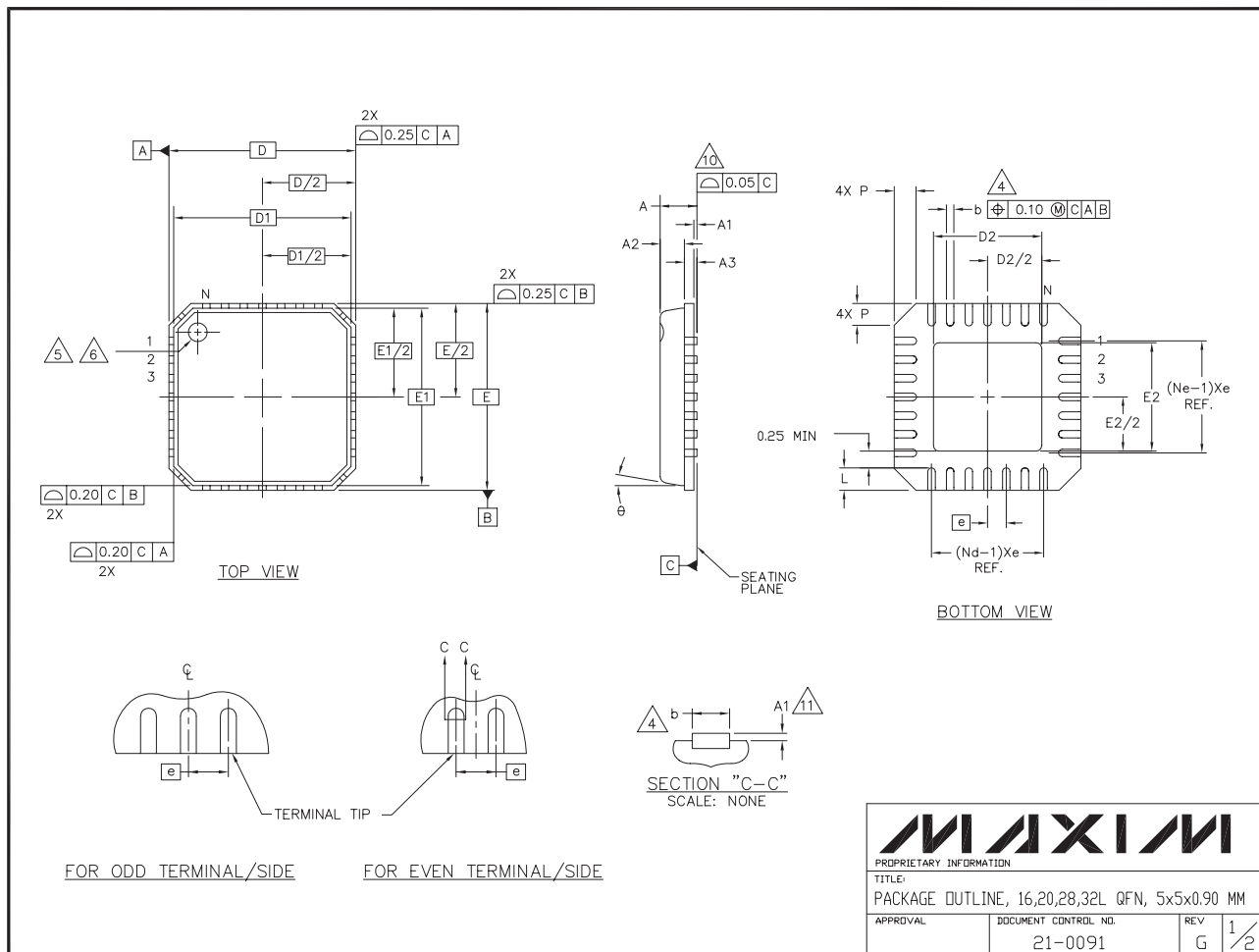

Quad SPST CMOS Analog Switches

Package Information (continued)

NOTES:

1. DIE THICKNESS ALLOWABLE IS 0.305mm MAXIMUM (.012 INCHES MAXIMUM)
2. DIMENSIONING & TOLERANCES CONFORM TO ASME Y14.5M. - 1994.
3. N IS THE NUMBER OF TERMINALS.
Nd IS THE NUMBER OF TERMINALS IN X-DIRECTION &
Ne IS THE NUMBER OF TERMINALS IN Y-DIRECTION.
4. DIMENSION b APPLIES TO PLATED TERMINAL AND IS MEASURED BETWEEN 0.20 AND 0.25mm FROM TERMINAL TIP.
5. THE PIN #1 IDENTIFIER MUST BE EXISTED ON THE TOP SURFACE OF THE PACKAGE BY USING INDENTATION MARK OR INK/ LASER MARKED.
6. EXACT SHAPE AND SIZE OF THIS FEATURE IS OPTIONAL.
7. ALL DIMENSIONS ARE IN MILLIMETERS.
8. PACKAGE WARPAGE MAX 0.05mm.
9. APPLIED FOR EXPOSED PAD AND TERMINALS.
EXCLUDE EMBEDDED PART OF EXPOSED PAD FROM MEASURING.
10. MEETS JEDEC M0220.
11. THIS PACKAGE OUTLINE APPLIES TO ANVIL SINGULATION (STEPPED SIDES) AND TO SAW SINGULATION (STRAIGHT SIDES) QFN STYLES.

SYMBOL	COMMON DIMENSIONS			N _T E
	MIN.	NOM.	MAX.	
A	0.80	0.90	1.00	
A1	0.00	0.01	0.05	
A2	0.00	0.65	1.00	
A3	0.20 REF.			
D	5.00 BSC			
D1	4.75 BSC			
E	5.00 BSC			
E1	4.75 BSC			
θ	0°	-	12°	
P	0	-	0.60	
D2	1.25	-	3.25	
E2	1.25	-	3.25	

SYMBOL	PITCH VARIATION B			N _T E	SYMBOL	PITCH VARIATION B			N _T E	SYMBOL	PITCH VARIATION C			N _T E	SYMBOL	PITCH VARIATION D			N _T E
	MIN.	NOM.	MAX.			MIN.	NOM.	MAX.			MIN.	NOM.	MAX.			MIN.	NOM.	MAX.	
Ⓢ	0.80 BSC			3	Ⓢ	0.65 BSC			3	Ⓢ	0.50 BSC			3	Ⓢ	0.50 BSC			3
N	16			3	N	20			3	N	28			3	N	32			3
Nd	4			3	Nd	5			3	Nd	7			3	Nd	8			3
Ne	4			3	Ne	5			3	Ne	7			3	Ne	8			3
L	0.35	0.55	0.75		L	0.35	0.55	0.75		L	0.35	0.55	0.75		L	0.30	0.40	0.50	
b	0.28	0.33	0.40	4	b	0.23	0.28	0.35	4	b	0.18	0.23	0.30	4	b	0.18	0.23	0.30	4



PROPRIETARY INFORMATION

TITLE:
PACKAGE OUTLINE, 16,20,28,32L QFN, 5x5x0.90 MM

APPROVAL	DOCUMENT CONTROL NO. 21-0091	REV G	2/2
----------	---------------------------------	----------	-----

Maxim cannot assume responsibility for use of any circuitry other than circuitry entirely embodied in a Maxim product. No circuit patent licenses are implied. Maxim reserves the right to change the circuitry and specifications without notice at any time.