



# LTC1263

## 12V, 60mA Flash Memory Programming Supply

### FEATURES

- **Guaranteed 60mA Output**
- **Regulated 12V  $\pm 5\%$  Output Voltage**
- **No Inductors**
- Supply Voltage Range: 4.75V to 5.5V
- $I_{CC}$  0.5 $\mu$ A Typ in Shutdown
- Low Power:  $I_{CC} = 300\mu$ A
- 8-Pin SO Package
- Same Pinout as LTC1262 and MAX662

### APPLICATIONS

- 12V Flash Memory Programming Supplies
- Compact 12V Op Amp Supplies
- Battery-Powered Systems

### DESCRIPTION

The LTC<sup>®</sup>1263 is a regulated 12V, 60mA output DC/DC converter. It provides the 12V  $\pm 5\%$  output necessary to program double byte-wide flash memories. The output provides 60mA from input voltages as low as 4.75V without using any inductors. Only four external capacitors are required to complete an extremely small, surface mountable circuit. The output can be momentarily shorted to ground without damaging the part.

The active high TTL compatible Shutdown pin can be directly connected to a microprocessor. In the shutdown mode, the supply current typically drops to 0.5 $\mu$ A.

The LTC1263 is available in an 8-pin SO package.

LT, LTC and LT are registered trademarks of Linear Technology Corporation.

### TYPICAL APPLICATION

Flash Memory Programming Supply

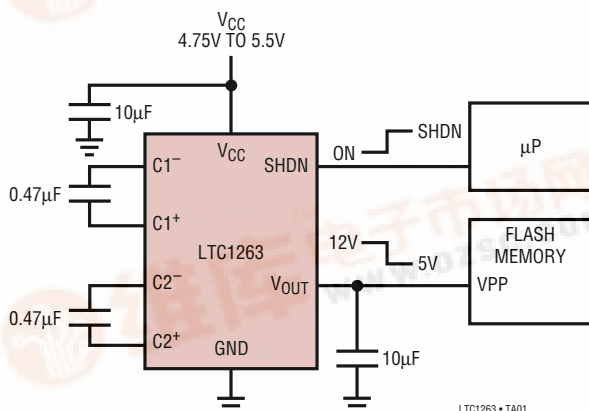

LTC1263 • TA01

Output Voltage vs Load

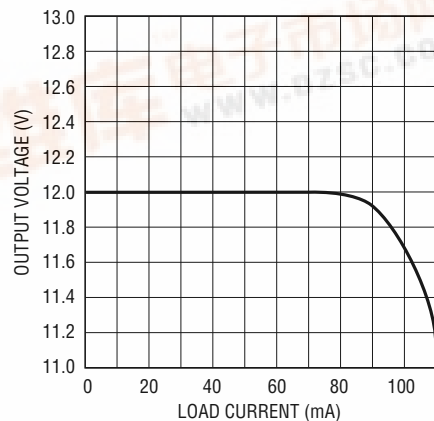

LTC1263 • TA02



# LTC1263

## ABSOLUTE MAXIMUM RATINGS

(Note 1)

Supply Voltage ( $V_{DD}$ )	6V
Input Voltage (SHDN)	-0.3V to $V_{CC} + 0.3V$
$I_{OUT}$ Continuous	90mA
Operating Temperature Range	0°C to 70°C
Storage Temperature Range	-65°C to 150°C
Lead Temperature (Soldering, 10 sec)	300°C

## PACKAGE/ORDER INFORMATION

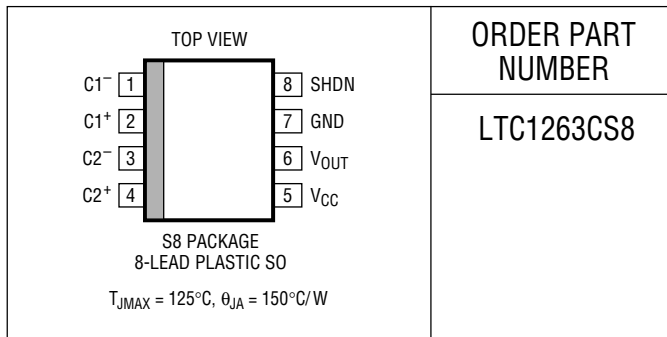

ORDER PART NUMBER

LTC1263CS8

Consult factory for Industrial and Military grade parts and TSSOP package option.

## ELECTRICAL CHARACTERISTICS $4.75V \leq V_{CC} \leq 5.5V$ , $T_A = 0^\circ C$ to $70^\circ C$ (Notes 2, 3).

SYMBOL	PARAMETER	CONDITIONS	MIN	TYP	MAX	UNITS	
$V_{OUT}$	Output Voltage	$0mA \leq I_{OUT} \leq 60mA$ , $V_{SHDN} = 0V$	●	11.4	12.6	V	
$I_{CC}$	Supply Current	No Load, $V_{SHDN} = 0V$	●	0.32	1.0	mA	
$I_{SHDN}$	Shutdown Supply Current	No Load, $V_{SHDN} = V_{CC}$	●	0.5	10	$\mu A$	
$f_{OSC}$	Oscillator Frequency	$V_{CC} = 5V$ , $I_{OUT} = 60mA$		300		kHz	
	Power Efficiency	$V_{CC} = 5V$ , $I_{OUT} = 60mA$		76		%	
$R_{SW}$	$V_{CC}$ to $V_{OUT}$ Switch Impedance	$V_{CC} = V_{SHDN} = 5V$ , $I_{OUT} = 0mA$	●	0.3	1	k $\Omega$	
$V_{IH}$	SHDN Input High Voltage		●	2.4		V	
$V_{IL}$	SHDN Input Low Voltage		●		0.8	V	
	SHDN Input Current	$V_{CC} = 5V$ , $V_{SHDN} = 0V$	●	-40	-20	-5	$\mu A$
		$V_{CC} = 5V$ , $V_{SHDN} = 5V$	●	-10	0	10	$\mu A$
$t_{ON}$	Turn-On Time	$C1 = C2 = 0.47\mu F$ , $C3 = C4 = 10\mu F$ (Note 4) (Figures 1, 2)		600		$\mu s$	
$t_{OFF}$	Turn-Off Time	$C1 = C2 = 0.47\mu F$ , $C3 = C4 = 10\mu F$ (Figures 1, 2)		10		ms	

The ● denotes specifications which apply over the full operating temperature range.

**Note 1:** Absolute Maximum Ratings are those values beyond which the life of a device may be impaired.

**Note 2:** All currents into device pins are positive; all currents out of device pins are negative. All voltages are referenced to ground unless otherwise specified.

**Note 3:** All typicals are given at  $V_{CC} = 5V$ ,  $T_A = 25^\circ C$ .

**Note 4:** A higher value output capacitor can be used but the “turn-on” and “turn-off” time will increase proportionally.

## TYPICAL PERFORMANCE CHARACTERISTICS

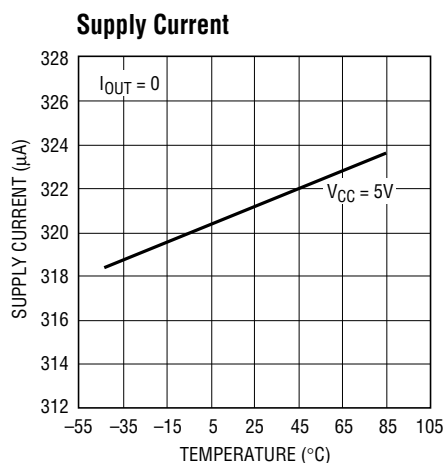

LTC1263 • TPC01

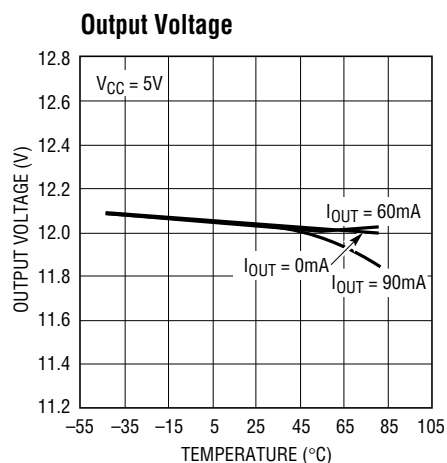

LTC1263 • TPC02

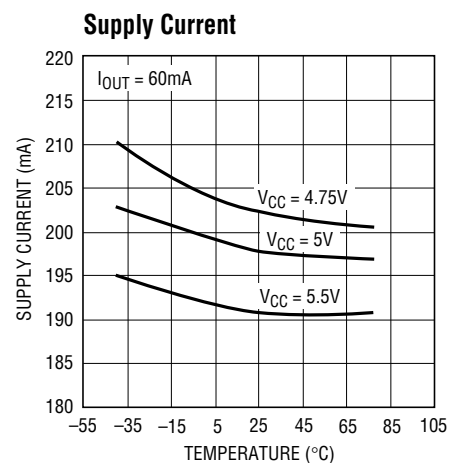

LTC1263 • TPC03

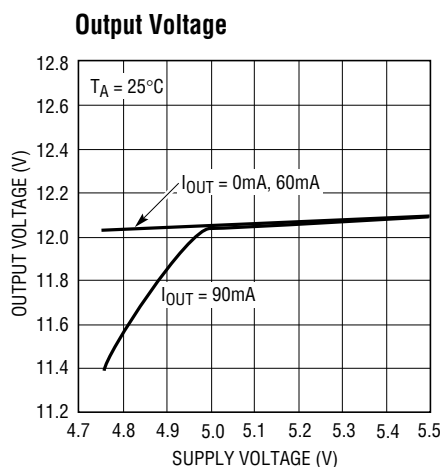

LTC1263 • TPC04

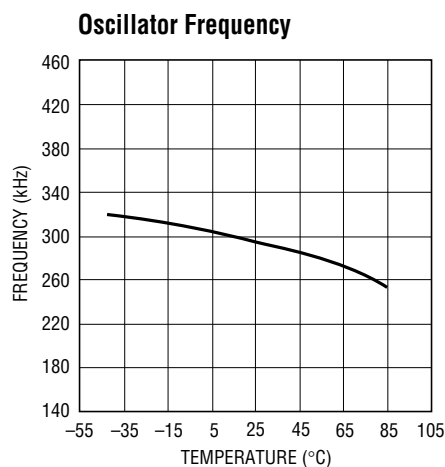

LTC1263 • TPC05

## PIN FUNCTIONS

**C1<sup>-</sup> (Pin 1):** First Charge Capacitor Negative Input. Connect a  $0.47\mu\text{F}$  capacitor (C1) between C1<sup>+</sup> and C1<sup>-</sup>.

**C1<sup>+</sup> (Pin 2):** First Charge Capacitor Positive Input. Connect a  $0.47\mu\text{F}$  capacitor (C1) between C1<sup>+</sup> and C1<sup>-</sup>.

**C2<sup>-</sup> (Pin 3):** Second Charge Capacitor Negative Input. Connect a  $0.47\mu\text{F}$  capacitor (C2) between C2<sup>+</sup> and C2<sup>-</sup>.

**C2<sup>+</sup> (Pin 4):** Second Charge Capacitor Positive Input. Connect a  $0.47\mu\text{F}$  capacitor (C2) between C2<sup>+</sup> and C2<sup>-</sup>.

**V<sub>CC</sub> (Pin 5):** Positive Supply Input.  $4.75\text{V} \leq V_{\text{CC}} \leq 5.5\text{V}$ . Requires a  $10\mu\text{F}$  bypass capacitor to ground (C4).

**V<sub>OUT</sub> (Pin 6):** 12V Output. Requires a  $10\mu\text{F}$  or a higher value bypass capacitor to ground (C3).  $V_{\text{OUT}} = V_{\text{CC}}$  when in the shutdown mode.

**GND (Pin 7):** Ground.

**SHDN (Pin 8):** Active-High TTL Logic Level Shutdown Pin. SHDN is internally pulled up to  $V_{\text{CC}}$ . Connect to GND for normal operation. In shutdown mode, the charge pump is turned off and  $V_{\text{OUT}} = V_{\text{CC}}$ .

# LTC1263

## BLOCK DIAGRAM

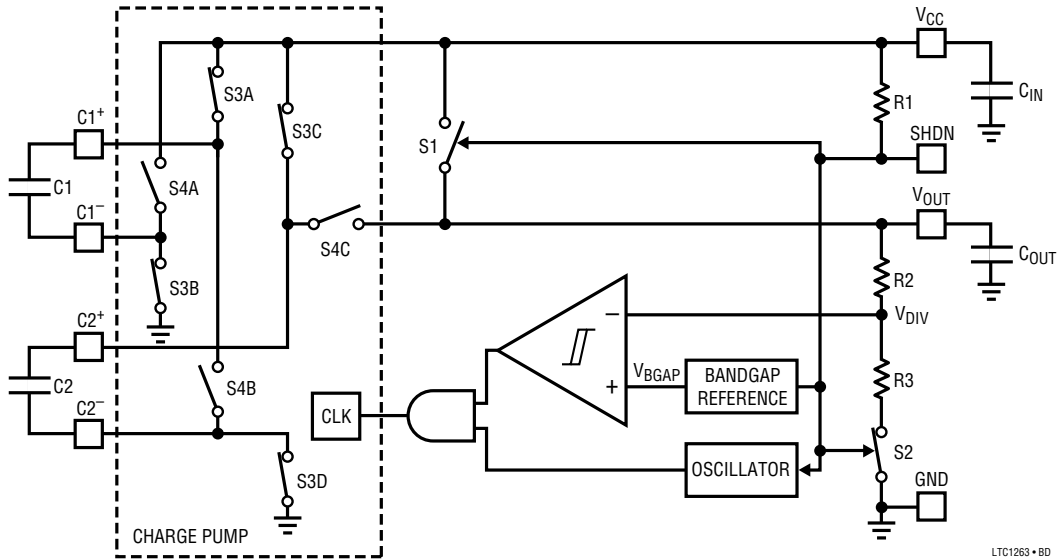

S1 AND S2 SHOWN WITH SHDN PIN LOW. S3A, S3B, S3C, S3D, S4A, S4B AND S4C SHOWN CHARGING C1 AND C2 WITH OSCILLATOR OUTPUT LOW AND  $V_{DIV} < V_{BGAP} - V_{HYST}$ . AT OSCILLATOR OUTPUT HIGH, S3A, S3B, S3C AND S3D OPEN WHILE S4A, S4B AND S4C CLOSE TO CHARGE  $V_{OUT}$ . COMPARATOR HYSTERESIS IS  $\pm V_{HYST}$

LTC1263 • BD

## TIMING DIAGRAMS

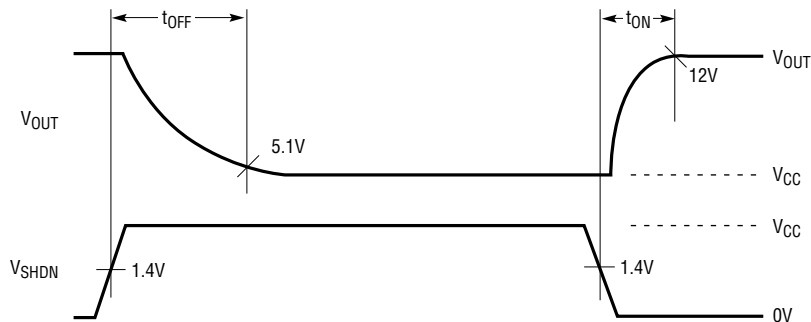
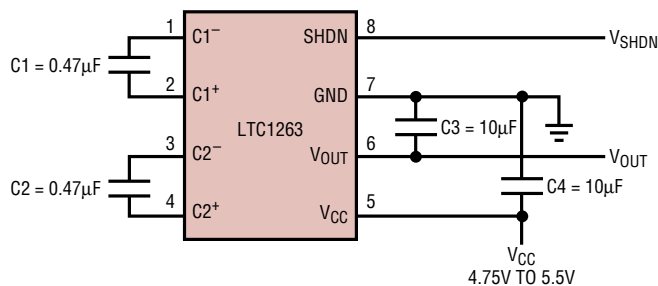

Figure 1. Timing Diagram

LTC1263 • F01



LTC1263 • F02

Figure 2. Timing Circuit

## OPERATION

The LTC1263 uses a charge pump tripler to generate 12V from a  $V_{CC}$  of 5V. The charge pump is clocked by an internal oscillator. The oscillator frequency is not critical and may vary from the typical value of 300kHz. When the oscillator output is low, C1 and C2 are each connected between  $V_{CC}$  and GND, charging them to  $V_{CC}$  (see Figure 3). When the oscillator output goes high, C1 and C2 are stacked in series with the bottom plate of C1 pulled to  $V_{CC}$  (see Figure 4). The top plate of C2 is switched to charge  $C_{OUT}$ , which enables  $V_{OUT}$  to rise.

$V_{OUT}$  is regulated to within 5% of 12V by an oscillator pulse gating scheme that turns the charge pump on and off based on the comparator results of  $V_{OUT}$  and a reference voltage. First, a resistor divider senses  $V_{OUT}$ ; if the output of the divider ( $V_{DIV}$ ) is less than the output of a bandgap ( $V_{BGAP}$ ) by the hysteresis voltage ( $V_{HYST}$ ) of the comparator, then oscillator pulses are applied to the charge pump to raise  $V_{OUT}$ . When  $V_{DIV}$  is above  $V_{BGAP}$  by  $V_{HYST}$ , the

oscillator pulses are prevented from clocking the charge pump. As a result,  $V_{OUT}$  drops until  $V_{DIV}$  is below  $V_{BGAP}$  by  $V_{HYST}$  again.

To ensure proper start-up when  $V_{OUT}$  is lower than  $V_{CC}$  and maintain proper operation when  $V_{OUT}$  is higher than  $V_{CC}$ , the gates of all internal switches are driven between GND and the higher of either  $V_{OUT}$  or  $V_{CC}$ .

To reduce supply current, the LTC1263 may be put into shutdown mode by “floating” the SHDN pin or connecting it to  $V_{CC}$ . In this mode, the bandgap, comparator, oscillator and resistor divider are switched off to reduce the supply current to typically 0.5 $\mu$ A. At the same time an internal switch shorts  $V_{OUT}$  to  $V_{CC}$ ;  $V_{OUT}$  takes 10ms (typ) to reach 5.1V (see  $t_{OFF}$  in Figure 1). When the SHDN pin is low, the LTC1263 exits shutdown and the charge pump operates to raise  $V_{OUT}$  to 12V.  $V_{OUT}$  takes 600 $\mu$ s (typ) to reach the lower regulation limit of 11.4V (see  $t_{ON}$  in Figure 1).

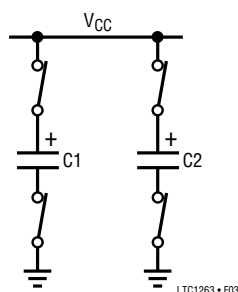

Figure 3. C1 and C2 Charge to  $V_{CC}$

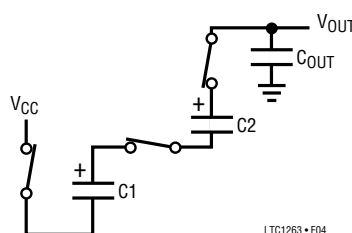

Figure 4. C1 and C2 Stacked in Series with C1<sup>-</sup> Tied to  $V_{CC}$

## APPLICATIONS INFORMATION

### Choice of Capacitors

The LTC1263 is tested with the capacitors shown in Figure 2. C1 and C2 are 0.47 $\mu$ F ceramic capacitors and  $C_{IN}$  and  $C_{OUT}$  are 10 $\mu$ F tantalum capacitors. Refer to Table 1 if other choices are desired.

Table 1. Recommended Capacitor Types and Values

CAPACITOR	CERAMIC	TANTALUM	ALUMINUM
C1, C2	0.47 $\mu$ F to 1 $\mu$ F	Not Recommended	Not Recommended
$C_{OUT}$	10 $\mu$ F (Min)	10 $\mu$ F (Min)	10 $\mu$ F (Min)
$C_{IN}$	10 $\mu$ F (Min)	10 $\mu$ F (Min)	10 $\mu$ F (Min)

C1 and C2 should be ceramic capacitors with values in the range of 0.47 $\mu$ F to 1 $\mu$ F. Higher values provide better load regulation. Tantalum capacitors are not recommended as the higher ESR of these capacitors degrades performance at high load currents and  $V_{CC} = 4.75V$ .

$C_{IN}$  and  $C_{OUT}$  can be ceramic, tantalum or electrolytic capacitors. The ESR of  $C_{OUT}$  introduces steps in the  $V_{OUT}$  waveform whenever the charge pump charges  $C_{OUT}$ . This tends to increase  $V_{OUT}$  ripple. Ceramic or tantalum capacitors are recommended for  $C_{OUT}$  if minimum ripple is

# LTC1263

## APPLICATIONS INFORMATION

desired. (The LTC1263 does not require a  $0.1\mu\text{F}$  capacitor between  $V_{CC}$  and  $V_{OUT}$  for stability.)

Besides using it to program flash memories, the LTC1263 can also provide multiple supply voltages with the help of

two diodes and two capacitors. Output voltages of 19V and  $-7\text{V}$  can easily be obtained. In other words, the LTC1263 can power dual supply ( $\pm 5\text{V}$ ) and single supply (15V) op amps.

## TYPICAL APPLICATIONS

### Dual Voltage Supply Output at 12V and 19V

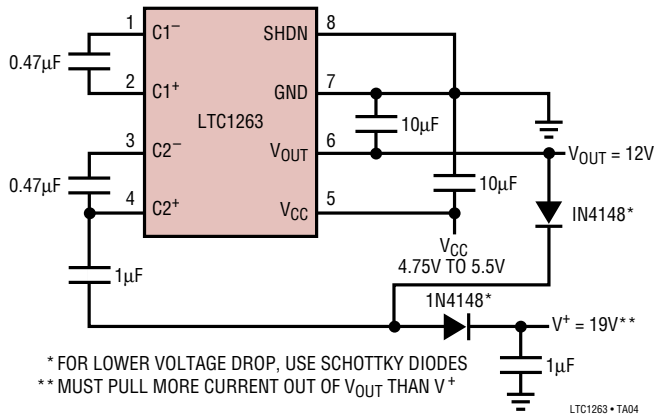

### Dual Supply Voltage Output at 12V and $-7\text{V}$

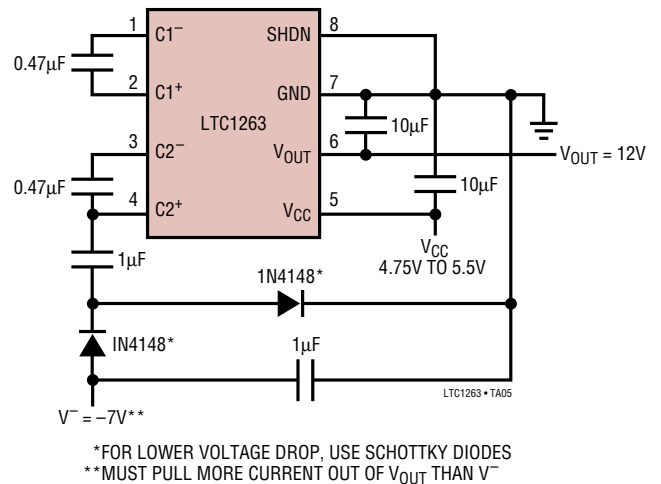

### Gain of 10 Amplifier Using LT<sup>®</sup>1006 Powered by LTC1263

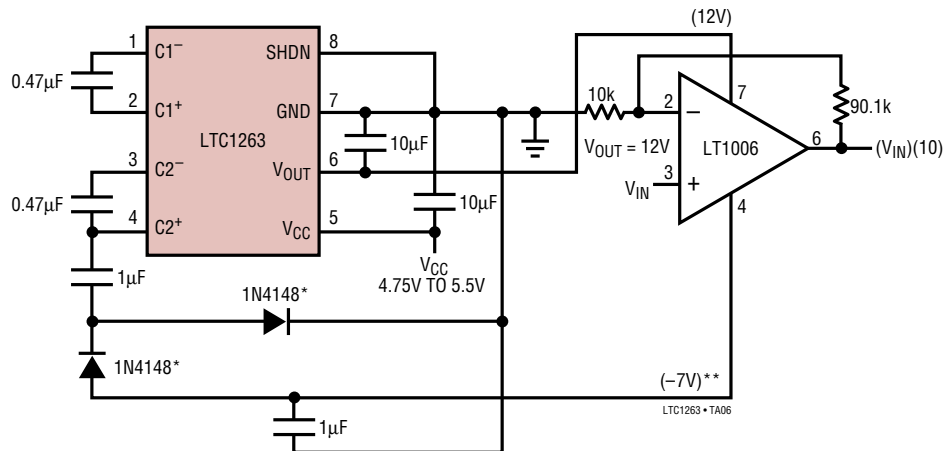

# TYPICAL APPLICATIONS

Dual Voltage Supply Output at 12V and -12V

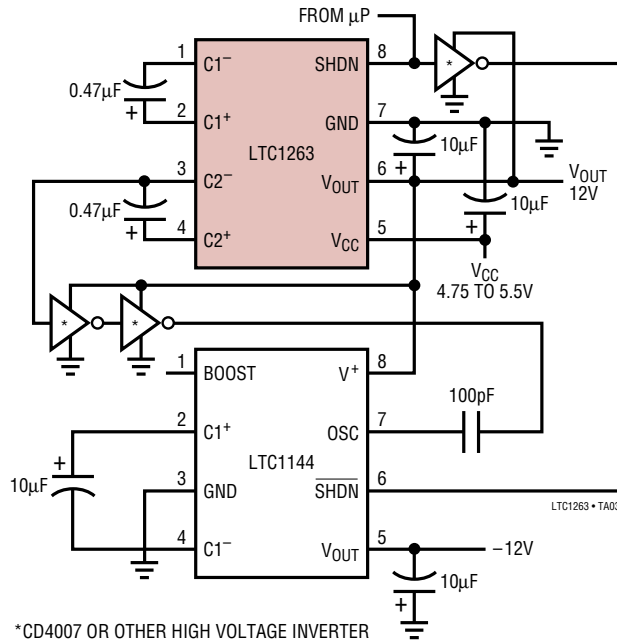

# PACKAGE DESCRIPTION

Dimensions in inches (millimeters) unless otherwise noted.

**S8 Package**  
**8-Lead Plastic Small Outline (Narrow 0.150)**  
 (LTC DWG # 05-08-1610)

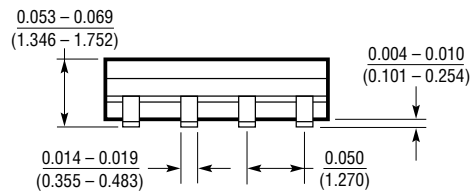
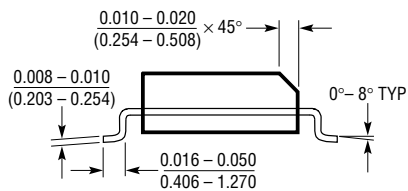
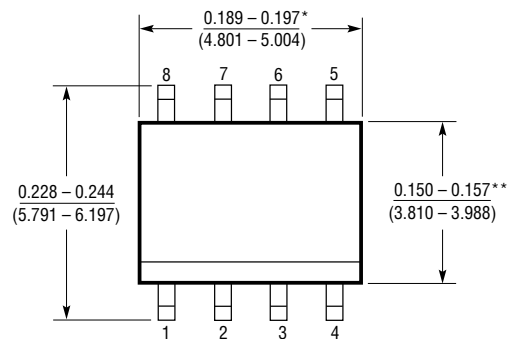

\* DIMENSION DOES NOT INCLUDE MOLD FLASH. MOLD FLASH SHALL NOT EXCEED 0.006" (0.152mm) PER SIDE

\*\* DIMENSION DOES NOT INCLUDE INTERLEAD FLASH. INTERLEAD FLASH SHALL NOT EXCEED 0.010" (0.254mm) PER SIDE

# LTC1263

## TYPICAL APPLICATION

5V to 3.3V/5A Converter with 12V/60mA Auxiliary Output

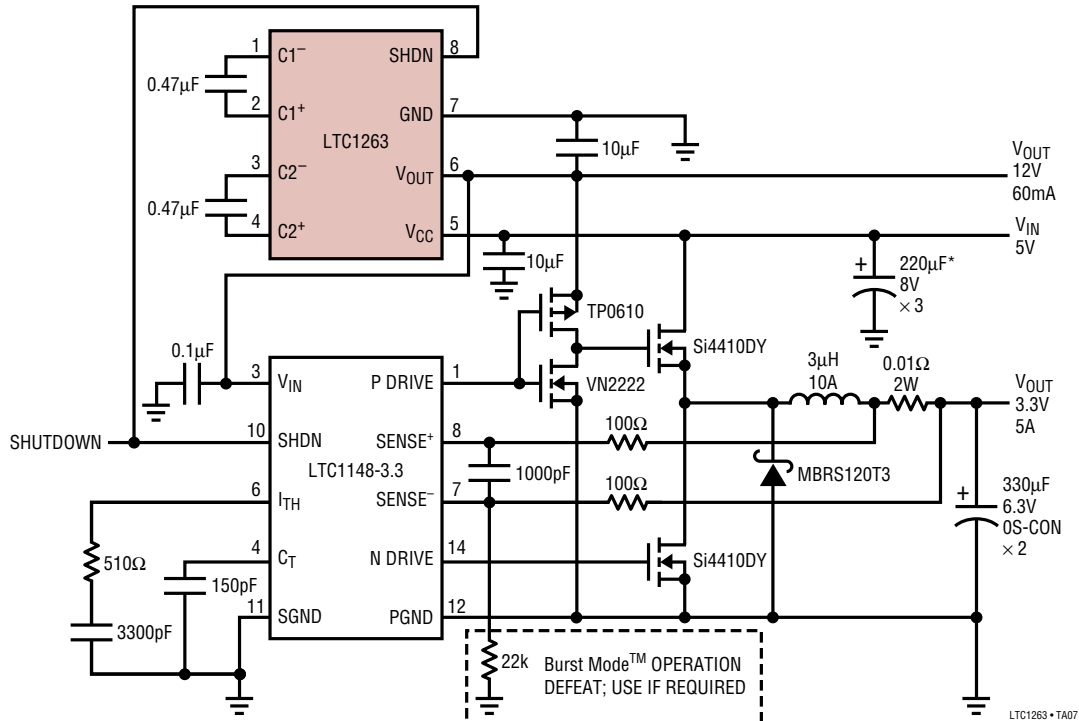

\*PANASONIC BCGCOKB220R OR EQUIVALENT  
Burst Mode IS A TRADEMARK OF LINEAR TECHNOLOGY CORPORATION.

LTC1263 • TA07

## RELATED PARTS

PART NUMBER	DESCRIPTION	COMMENTS
LTC1044A	12V CMOS Voltage Converter	1.5V to 12V Supply Range, 95% Efficiency, $\pm V_{OUT}$
LT1106/LT1107/LT1108	Micropower DC/DC Converter, 5V and 12V	Adjustable $V_{OUT}$ from $V_{IN} = 3V$ , Use Inductor
LTC1262	12V, 30mA Flash Memory Program Supply	1/2 Source Current as LTC1263, Cannot Short $V_{OUT}$ to GND
LT1301/LT1302/LT1303	Micropower High Efficiency 5V/12V, DC/DC Converter	5V at 600mA or 12V at 120mA, Use Inductor
LT1312	Single PCMCIA VPP Driver/Regulator	120mA Output, Current Limit, Thermal Shutdown
LTC1429	Regulating Positive to Negative Charge Pump	Fixed -4.1V or Adjustable Output, No Inductors