



# LT1787/LT1787HV

## Precision, High Side Current Sense Amplifiers

### FEATURES

- **Input Offset Voltage: 75µV (Max)**
- **60V Supply Operation (LT1787HV)**
- **12-Bit Dynamic Range**
- Operating Current: 60µA
- User-Selectable External Sense Resistor
- Bidirectional High Side Current Sensing
- Unidirectional or Bidirectional Output
- Input Noise Filtering
- Available in 8-Lead SO and MSOP Packages
- -40°C to 125°C Operating Temperature Range

### APPLICATIONS

- Battery Monitoring
- Power Monitoring
- Portable Phones
- Cellular Phones
- Portable Test/Measurement Systems
- Battery-Operated Systems

### DESCRIPTION

The LT<sup>®</sup>1787 is a complete micropower precision high side current sense amplifier. The LT1787 monitors bidirectional currents via the voltage across an external sense resistor. A current or voltage output indicates the direction and magnitude of the sense current. The LT1787 delivers greater than a 12-bit dynamic range with ultralow 40µV input offset voltage compared to a typical 250mV full-scale input voltage. A fixed gain of 8 is set by onboard precision resistors. Input signal filtering is easily implemented with a capacitor between the FIL<sup>-</sup> and FIL<sup>+</sup> pins. The LT1787HV operates from 2.5V to 60V total supply voltage and the LT1787 operates from 2.5V to 36V total supply voltage. Both versions have a PSRR in excess of 120dB. The LT1787/LT1787HV draw only 60µA and are available in 8-lead SO and MSOP packages.

LT, LTC and LT are registered trademarks of Linear Technology Corporation.

### TYPICAL APPLICATION

12-Bit Dynamic Resolution Unidirectional Output into LTC<sup>®</sup>1286 ADC

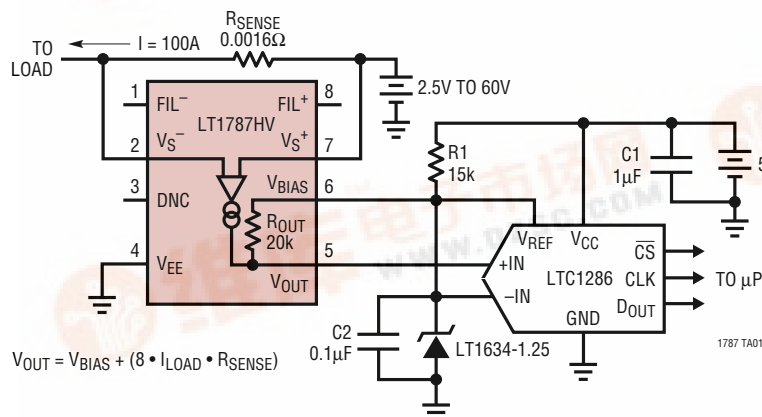

Input Offset Voltage vs Supply Voltage

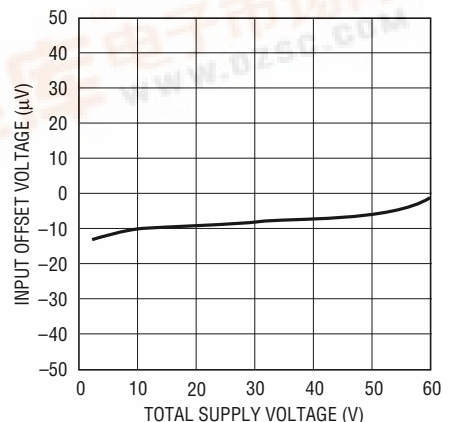

1787 TA01b



# LT1787/LT1787HV

## ABSOLUTE MAXIMUM RATINGS (Notes 1, 2)

Differential Sense Voltage ..... $\pm 10V$	Specified Temperature Range (Note 4)
Total Supply Voltage (LT1787) ..... 40V	LT1787C ..... $-40^{\circ}C$ to $85^{\circ}C$
Total Supply Voltage (LT1787HV) ..... 65V	LT1787I ..... $-40^{\circ}C$ to $85^{\circ}C$
Output Voltage ..... $(V_{EE} - 0.3V)$ to $(V_{EE} + 35V)$	LT1787H ..... $-40^{\circ}C$ to $125^{\circ}C$
Output Bias Voltage ..... $(V_{EE} - 0.3V)$ to $(V_{EE} + 35V)$	Storage Temperature Range ..... $-65^{\circ}C$ to $150^{\circ}C$
Operating Temperature Range (Note 3)	Lead Temperature (Soldering, 10 sec) ..... $300^{\circ}C$
LT1787C ..... $-40^{\circ}C$ to $85^{\circ}C$	
LT1787I ..... $-40^{\circ}C$ to $85^{\circ}C$	
LT1787H ..... $-40^{\circ}C$ to $125^{\circ}C$	

## PACKAGE/ORDER INFORMATION

<p>MS8 PACKAGE 8-LEAD PLASTIC MSOP</p> <p>* DO NOT CONNECT</p> <p><math>T_{JMAX} = 150^{\circ}C, \theta_{JA} = 250^{\circ}C/W</math></p>	ORDER PART NUMBER	<p>S8 PACKAGE 8-LEAD PLASTIC SO</p> <p>* DO NOT CONNECT</p> <p><math>T_{JMAX} = 150^{\circ}C, \theta_{JA} = 190^{\circ}C/W</math></p>	ORDER PART NUMBER
	LT1787CMS8 LT1787IMS8 LT1787HVCMS8 LT1787HVIMS8		LT1787CS8 LT1787IS8 LT1787HS8 LT1787HVCS8 LT1787HVIS8 LT1787HVHS8
	MS8 PART MARKING		S8 PART MARKING
	LTGM LTGN LTKJ LTKK		1787      1787HV 1787I    787HVI 1787H    787HVH

Consult factory for parts specified with wider operating temperature ranges.

## ELECTRICAL CHARACTERISTICS (Note 5)

The ● denotes the specifications which apply over the temperature range  $0^{\circ}C \leq T_A \leq 70^{\circ}C$ , otherwise specifications are at  $T_A = 25^{\circ}C$ . Total supply =  $(V_S - V_{EE}) = 2.5V$  to  $36V$  (LT1787C),  $2.5V$  to  $60V$  (LT1787HVC) unless otherwise specified.

SYMBOL	PARAMETER	CONDITIONS	MIN	TYP	MAX	UNITS	
$V_S, V_S^+$	Sense Amplifier Supply Voltage	Single Supply Operation (LT1787)	●	2.5	36	V	
		Single Supply Operation (LT1787HV)	●	2.5	60	V	
$V_{SENSE}$	Input Sense Voltage Full Scale	$V_{SENSE} = V_S^+ - V_S^-$ , $V_S = 10V$ , $V_{BIAS} = 5V$ , $A_V = 8 \pm 10\%$	●	500		mV	
$V_{OS}$	Input Offset Voltage (S8)	$I_{OUT} = 0$ , $V_S$ Supply = 5V $0^{\circ}C \leq T_A \leq 70^{\circ}C$	●	-75	$\pm 40$	75	$\mu V$
			●	-135		135	$\mu V$
			●	-100		100	$\mu V$
		●	-160		160	$\mu V$	
	Input Offset Voltage (MS8)	$I_{OUT} = 0$ , $V_S$ Supply = 5V $0^{\circ}C \leq T_A \leq 70^{\circ}C$	●	-125	$\pm 40$	125	$\mu V$
			●	-230		230	$\mu V$
		●	-150		150	$\mu V$	
		●	-250		250	$\mu V$	
		●	-150		150	$\mu V$	
		●	-250		250	$\mu V$	

## ELECTRICAL CHARACTERISTICS (Note 5)

The ● denotes the specifications which apply over the temperature range  $0^{\circ}\text{C} \leq T_A \leq 70^{\circ}\text{C}$ , otherwise specifications are at  $T_A = 25^{\circ}\text{C}$ . Total supply =  $(V_S^- - V_{EE}) = 2.5\text{V to } 36\text{V}$  (LT1787C),  $2.5\text{V to } 60\text{V}$  (LT1787HVC) unless otherwise specified.

SYMBOL	PARAMETER	CONDITIONS		MIN	TYP	MAX	UNITS
$V_{OS\ TC}$	Temperature Coefficient of $V_{OS}$	$V_S$ Supply = 5V (Note 6)	●		0.5	2	$\mu\text{V}/^{\circ}\text{C}$
$I_{OUT(O)}$	No-Load Output Current Error	$V_{SENSE} = 0\text{V}$			4		nA
$V_{OUT(O)}$	No-Load Output Voltage Error (S8)	$V_{SENSE} = 0\text{V}$ , $V_S$ Supply = 5V $0^{\circ}\text{C} \leq T_A \leq 70^{\circ}\text{C}$	●	-600 -1080		600 1080	$\mu\text{V}$ $\mu\text{V}$
	No-Load Output Voltage Error (MS8)	$V_{SENSE} = 0\text{V}$ , $V_S$ Supply = 5V $0^{\circ}\text{C} \leq T_A \leq 70^{\circ}\text{C}$	●	-1000 -1840		1000 1840	$\mu\text{V}$ $\mu\text{V}$
$g_m$	Transconductance, $I_{OUT}/V_{SENSE}$	$\pm V_{SENSE} = 10\text{mV}, 50\text{mV}, 100\text{mV}, 150\text{mV}, 250\text{mV}$ , $V_S$ Supply = Total Supply + $ V_{SENSE} $			400		$\mu\text{A}/\text{V}$
$A_V$	Gain, $V_{OUT}/V_{SENSE}$	$\pm V_{SENSE} = 100\text{mV}$ , $V_S$ Supply = 5V	●	7.76	8	8.24	V/V
	Output Voltage Gain Error	$\pm V_{SENSE} = 100\text{mV}$ , $V_S$ Supply = 5V	●	-3	1	3	%
$V_S\ PSRR$	$V_S$ Supply Rejection Ratio	$V_{SENSE} = 0\text{V}$ , $V_S$ Supply = 2.5V to 36V (LT1787)	●	120	135		dB
		$V_{SENSE} = 0\text{V}$ , $V_S$ Supply = 2.5V to 60V (LT1787HV)	●	120	135		dB
$V_{EE}\ PSRR$	Negative Supply Rejection Ratio	$V_{SENSE} = 0\text{V}$ , $V_S$ Supply = 15V, $V_{BIAS} = 0\text{V}$ , $V_{EE} = -1\text{V to } -15\text{V}$ (LT1787)	●	100	130		dB
		$V_{SENSE} = 0\text{V}$ , $V_S$ Supply = 40V, $V_{BIAS} = 0\text{V}$ , $V_{EE} = -1\text{V to } -15\text{V}$ (LT1787HV)	●	100	130		dB
$\frac{\Delta V_{OS}}{\Delta V_{BIAS}}$	Change in Input Offset Voltage with Change in $V_{BIAS}$ Voltage	$V_{SENSE} = 0\text{V}$ , $V_S$ Supply = 36V, $V_{BIAS} = 0.5\text{V to } 25\text{V}$ (LT1787)	●	100	130		dB
		$V_{SENSE} = 0\text{V}$ , $V_S$ Supply = 60V, $V_{BIAS} = 0.5\text{V to } 25\text{V}$ (LT1787HV)	●	100	130		dB
$I_S^+(O)$	Positive Input Sense Current	$V_{SENSE} = 0\text{V}$	●		10	20	$\mu\text{A}$
$I_S^-(O)$	Negative Input Sense Current	$V_{SENSE} = 0\text{V}$	●		50	100	$\mu\text{A}$
$I_{EE(O)}$	Negative Supply Current	$V_{SENSE} = 0\text{V}$	●		60	120	$\mu\text{A}$
$I_{OUT}$	Output Current	$V_{SENSE} = \pm 128\text{mV}$			$\pm 50$		$\mu\text{A}$
$V_{OUT}$	Output Voltage	$V_{SENSE} = \pm 128\text{mV}$ , $V_S^+ \geq 3.3\text{V}$			$V_{BIAS} \pm 1.024$		V
	Ripple Rejection	$V_S^+ = V_S^- = 20\text{V}$ , $\Delta V_S$ Supply = 1V, $f = 1\text{kHz}$	●	80	88		dB
$V_{OMIN}$	Minimum Output Voltage	$V_{SENSE} = 0\text{V}$ , $V_{BIAS} = 0\text{V}$	●		30	45	mV
		$V_{SENSE} = V_S^+ - V_S^- = -128\text{mV}$ , $V_{BIAS} = 0\text{V}$			10		mV
		$V_{SENSE} = 0\text{V}$ , $V_{BIAS} = 0\text{V}$	●		30	49	mV
		$V_{SENSE} = V_S^+ - V_S^- = -128\text{mV}$ , $V_{BIAS} = 0\text{V}$			10		mV
	Unipolar Output Saturation Voltage	$V_{SENSE} = 2\text{mV}$ , $V_{BIAS} = 0\text{V}$			32	50	mV
		$V_{SENSE} = 4\text{mV}$ , $V_{BIAS} = 0\text{V}$			38	55	mV
		$V_{SENSE} = 5\text{mV}$ , $V_{BIAS} = 0\text{V}$			43	60	mV
		$V_{SENSE} = 6\text{mV}$ , $V_{BIAS} = 0\text{V}$			49	65	mV
		$V_{SENSE} = 2\text{mV}$ , $V_{BIAS} = 0\text{V}$	●		32	54	mV
		$V_{SENSE} = 4\text{mV}$ , $V_{BIAS} = 0\text{V}$	●		38	59	mV
		$V_{SENSE} = 5\text{mV}$ , $V_{BIAS} = 0\text{V}$	●		43	64	mV
		$V_{SENSE} = 6\text{mV}$ , $V_{BIAS} = 0\text{V}$	●		49	69	mV
$V_{OMAX}$	Maximum Output Voltage			$V_S^+ - 0.75$		V	
$R_{G1A}, R_{G2A}$	Input Gain-Setting Resistor	Pin 1 to Pin 2, Pin 7 to Pin 8		1.25		k $\Omega$	
$R_{OUT}$	Output Resistor	Pin 5 to Pin 6		20		k $\Omega$	

# LT1787/LT1787HV

## ELECTRICAL CHARACTERISTICS

The ● denotes the specifications which apply over the temperature range  $-40^{\circ}\text{C} \leq T_A \leq 85^{\circ}\text{C}$ , otherwise specifications are at  $T_A = 25^{\circ}\text{C}$ . Total supply =  $(V_S^- - V_{EE}) = 2.5\text{V to }36\text{V}$  (LT1787I),  $2.5\text{V to }60\text{V}$  (LT1787HVI) unless otherwise specified. (Note 5)

SYMBOL	PARAMETER	CONDITIONS	MIN	TYP	MAX	UNITS	
$V_S^-, V_S^+$	Sense Amplifier Supply Voltage	Single Supply Operation (LT1787)	●	2.5	36	V	
		Single Supply Operation (LT1787HV)	●	2.5	60	V	
$V_{SENSE}$	Input Sense Voltage Full Scale	$V_{SENSE} = V_S^+ - V_S^-$ , $V_S = 10\text{V}$ , $V_{BIAS} = 5\text{V}$ , $A_V = 8 \pm 10\%$	●	500		mV	
$V_{OS}$	Input Offset Voltage (S8)	$I_{OUT} = 0$ , $V_S$ Supply = 5V $-40^{\circ}\text{C} \leq T_A \leq 85^{\circ}\text{C}$	●	-75 -200	$\pm 40$ 75 200	$\mu\text{V}$ $\mu\text{V}$	
		$I_{OUT} = 0$ (LT1787) $-40^{\circ}\text{C} \leq T_A \leq 85^{\circ}\text{C}$	●	-100 -225	100 225	$\mu\text{V}$ $\mu\text{V}$	
		$I_{OUT} = 0$ (LT1787HV) $-40^{\circ}\text{C} \leq T_A \leq 85^{\circ}\text{C}$	●	-100 -225	100 225	$\mu\text{V}$ $\mu\text{V}$	
	Input Offset Voltage (MS8)	$I_{OUT} = 0$ , $V_S$ Supply = 5V $-40^{\circ}\text{C} \leq T_A \leq 85^{\circ}\text{C}$	●	-125 -250	$\pm 40$ 125 250	$\mu\text{V}$ $\mu\text{V}$	
		$I_{OUT} = 0$ (LT1787) $-40^{\circ}\text{C} \leq T_A \leq 85^{\circ}\text{C}$	●	-150 -280	150 280	$\mu\text{V}$ $\mu\text{V}$	
		$I_{OUT} = 0$ (LT1787HV) $-40^{\circ}\text{C} \leq T_A \leq 85^{\circ}\text{C}$	●	-150 -280	150 280	$\mu\text{V}$ $\mu\text{V}$	
$V_{OS}$ TC	Temperature Coefficient of $V_{OS}$	$V_S$ Supply = 5V (Note 6)	●	0.5	2	$\mu\text{V}/^{\circ}\text{C}$	
$I_{OUT(0)}$	No-Load Output Current Error	$V_{SENSE} = 0\text{V}$		4		nA	
$V_{OUT(0)}$	No-Load Output Voltage Error (S8)	$V_{SENSE} = 0\text{V}$ , $V_S$ Supply = 5V $-40^{\circ}\text{C} \leq T_A \leq 85^{\circ}\text{C}$	●	-600 -1600	600 1600	$\mu\text{V}$ $\mu\text{V}$	
	No-Load Output Voltage Error (MS8)	$V_{SENSE} = 0\text{V}$ , $V_S$ Supply = 5V $-40^{\circ}\text{C} \leq T_A \leq 85^{\circ}\text{C}$	●	-1000 -2000	1000 2000	$\mu\text{V}$ $\mu\text{V}$	
$g_m$	Transconductance, $I_{OUT}/V_{SENSE}$	$\pm V_{SENSE} = 10\text{mV}, 50\text{mV}, 100\text{mV}, 150\text{mV}, 250\text{mV}$ , $V_S$ Supply = Total Supply + $ V_{SENSE} $		400		$\mu\text{A}/\text{V}$	
$A_V$	Gain, $V_{OUT}/V_{SENSE}$	$\pm V_{SENSE} = 100\text{mV}$ , $V_S$ Supply = 5V	●	7.76	8	8.24	V/V
	Output Voltage Gain Error	$\pm V_{SENSE} = 100\text{mV}$ , $V_S$ Supply = 5V	●	-3	1	3	%
$V_S$ PSRR	$V_S$ Supply Rejection Ratio	$V_{SENSE} = 0\text{V}$ , $V_S$ Supply = 2.5V to 36V (LT1787)	●	120	135		dB
		$V_{SENSE} = 0\text{V}$ , $V_S$ Supply = 2.5V to 60V (LT1787HV)	●	120	135		dB
$V_{EE}$ PSRR	Negative Supply Rejection Ratio	$V_{SENSE} = 0\text{V}$ , $V_S$ Supply = 15V, $V_{BIAS} = 0\text{V}$ , $V_{EE} = -1\text{V to }-15\text{V}$ (LT1787)	●	100	130		dB
		$V_{SENSE} = 0\text{V}$ , $V_S$ Supply = 40V, $V_{BIAS} = 0\text{V}$ , $V_{EE} = -1\text{V to }-15\text{V}$ (LT1787HV)	●	100	130		dB
$\frac{\Delta V_{OS}}{\Delta V_{BIAS}}$	Change in Input Offset Voltage with Change in $V_{BIAS}$ Voltage	$V_{SENSE} = 0\text{V}$ , $V_S$ Supply = 36V, $V_{BIAS} = 0.5\text{V to }25\text{V}$ (LT1787)	●	100	130		dB
		$V_{SENSE} = 0\text{V}$ , $V_S$ Supply = 60V, $V_{BIAS} = 0.5\text{V to }25\text{V}$ (LT1787HV)	●	100	130		dB
$I_S^+(0)$	Positive Input Sense Current	$V_{SENSE} = 0\text{V}$	●	10	20	$\mu\text{A}$	
$I_S^-(0)$	Negative Input Sense Current	$V_{SENSE} = 0\text{V}$	●	50	100	$\mu\text{A}$	
$I_{EE(0)}$	Negative Supply Current	$V_{SENSE} = 0\text{V}$	●	60	120	$\mu\text{A}$	
$I_{OUT}$	Output Current	$V_{SENSE} = \pm 128\text{mV}$		$\pm 50$		$\mu\text{A}$	
$V_{OUT}$	Output Voltage	$V_{SENSE} = \pm 128\text{mV}$ , $V_S^+ \geq 3.3\text{V}$		$V_{BIAS} \pm 1.024$		V	
	Ripple Rejection	$V_S^+ = V_S^- = 20\text{V}$ , $\Delta V_S$ Supply = 1V, $f = 1\text{kHz}$	●	80	88	dB	
$V_{OMIN}$	Minimum Output Voltage	$V_{SENSE} = 0\text{V}$ , $V_{BIAS} = 0\text{V}$ $V_{SENSE} = V_S^+ - V_S^- = -128\text{mV}$ , $V_{BIAS} = 0\text{V}$		30	45	mV	
				10		mV	
		$V_{SENSE} = 0\text{V}$ , $V_{BIAS} = 0\text{V}$ $V_{SENSE} = V_S^+ - V_S^- = -128\text{mV}$ , $V_{BIAS} = 0\text{V}$	●	30	51	mV	
			10		mV		

## ELECTRICAL CHARACTERISTICS

The ● denotes the specifications which apply over the temperature range  $-40^{\circ}\text{C} \leq T_A \leq 85^{\circ}\text{C}$ , otherwise specifications are at  $T_A = 25^{\circ}\text{C}$ . Total supply =  $(V_S^- - V_{EE}) = 2.5\text{V to }36\text{V}$  (LT1787I), 2.5V to 60V (LT1787HVI) unless otherwise specified. (Note 5)

SYMBOL	PARAMETER	CONDITIONS	MIN	TYP	MAX	UNITS
	Unipolar Output Saturation Voltage	$V_{\text{SENSE}} = 2\text{mV}, V_{\text{BIAS}} = 0\text{V}$		32	50	mV
		$V_{\text{SENSE}} = 4\text{mV}, V_{\text{BIAS}} = 0\text{V}$		38	55	mV
		$V_{\text{SENSE}} = 5\text{mV}, V_{\text{BIAS}} = 0\text{V}$		43	60	mV
		$V_{\text{SENSE}} = 6\text{mV}, V_{\text{BIAS}} = 0\text{V}$		49	65	mV
		$V_{\text{SENSE}} = 2\text{mV}, V_{\text{BIAS}} = 0\text{V}$	●	32	56	mV
		$V_{\text{SENSE}} = 4\text{mV}, V_{\text{BIAS}} = 0\text{V}$	●	38	61	mV
		$V_{\text{SENSE}} = 5\text{mV}, V_{\text{BIAS}} = 0\text{V}$	●	43	66	mV
		$V_{\text{SENSE}} = 6\text{mV}, V_{\text{BIAS}} = 0\text{V}$	●	49	71	mV
$V_{\text{OMAX}}$	Maximum Output Voltage		$V_S^+ - 0.75$			V
$R_{G1A}, R_{G2A}$	Input Gain-Setting Resistor	Pin 1 to Pin 2, Pin 7 to Pin 8		1.25		k $\Omega$
$R_{\text{OUT}}$	Output Resistor	Pin 5 to Pin 6		20		k $\Omega$

The ● denotes the specifications which apply over the temperature range  $-40^{\circ}\text{C} \leq T_A \leq 125^{\circ}\text{C}$ , otherwise specifications are at  $T_A = 25^{\circ}\text{C}$ . Total supply =  $(V_S^- - V_{EE}) = 2.5\text{V to }36\text{V}$  (LT1787H), 2.5V to 60V (LT1787HVH) unless otherwise specified. (Note 5)

$V_S^-, V_S^+$	Sense Amplifier Supply Voltage	Single Supply Operation (LT1787H) Single Supply Operation (LT1787HVH)	● ●	2.5 2.5	36 60	V V	
$V_{\text{SENSE}}$	Input Sense Voltage Full Scale	$V_{\text{SENSE}} = V_S^+ - V_S^-, V_S = 10\text{V}, V_{\text{BIAS}} = 5\text{V}, A_V = 8 \pm 10\%$	●	500		mV	
$V_{\text{OS}}$	Input Offset Voltage	$I_{\text{OUT}} = 0, V_S$ Supply = 5V $-40^{\circ}\text{C} \leq T_A \leq 125^{\circ}\text{C}$	●	-75 -400	$\pm 40$ 400	$\mu\text{V}$ $\mu\text{V}$	
		$I_{\text{OUT}} = 0$ (LT1787H) $-40^{\circ}\text{C} \leq T_A \leq 125^{\circ}\text{C}$	●	-100 -550	100 550	$\mu\text{V}$ $\mu\text{V}$	
		$I_{\text{OUT}} = 0$ (LT1787HVH) $-40^{\circ}\text{C} \leq T_A \leq 125^{\circ}\text{C}$	●	-100 -550	100 550	$\mu\text{V}$ $\mu\text{V}$	
$V_{\text{OS TC}}$	Temperature Coefficient of $V_{\text{OS}}$	$V_S$ Supply = 5V (Note 6)	●	0.5	4	$\mu\text{V}/^{\circ}\text{C}$	
$I_{\text{OUT}(0)}$	No-Load Output Current Error	$V_{\text{SENSE}} = 0\text{V}$		4		nA	
$V_{\text{OUT}(0)}$	No-Load Output Voltage Error	$V_{\text{SENSE}} = 0\text{V}, V_S$ Supply = 5V $-40^{\circ}\text{C} \leq T_A \leq 125^{\circ}\text{C}$	●	-600 -3200	600 3200	$\mu\text{V}$ $\mu\text{V}$	
$g_m$	Transconductance, $I_{\text{OUT}}/V_{\text{SENSE}}$	$\pm V_{\text{SENSE}} = 10\text{mV}, 50\text{mV}, 100\text{mV}, 150\text{mV}, 250\text{mV},$ $V_S$ Supply = Total Supply + $ V_{\text{SENSE}} $		400		$\mu\text{A}/\text{V}$	
$A_V$	Gain, $V_{\text{OUT}}/V_{\text{SENSE}}$	$\pm V_{\text{SENSE}} = 100\text{mV}, V_S$ Supply = 5V	●	7.76	8	8.24	V/V
	Output Voltage Gain Error	$\pm V_{\text{SENSE}} = 100\text{mV}, V_S$ Supply = 5V	●	-3	1	3	%
$V_S$ PSRR	$V_S$ Supply Rejection Ratio	$V_{\text{SENSE}} = 0\text{V}, V_S$ Supply = 2.5V to 36V (LT1787H)	●	100	130		dB
		$V_{\text{SENSE}} = 0\text{V}, V_S$ Supply = 2.5V to 60V (LT1787HVH)	●	100	130		dB
$V_{EE}$ PSRR	Negative Supply Rejection Ratio	$V_{\text{SENSE}} = 0\text{V}, V_S$ Supply = 15V, $V_{\text{BIAS}} = 0\text{V},$ $V_{EE} = -1\text{V to }-15\text{V}$ (LT1787H)	●	100	130		dB
		$V_{\text{SENSE}} = 0\text{V}, V_S$ Supply = 40V, $V_{\text{BIAS}} = 0\text{V},$ $V_{EE} = -1\text{V to }-15\text{V}$ (LT1787HVH)	●	100	130		dB
$\frac{\Delta V_{\text{OS}}}{\Delta V_{\text{BIAS}}}$	Change in Input Offset Voltage with Change in $V_{\text{BIAS}}$ Voltage	$V_{\text{SENSE}} = 0\text{V}, V_S$ Supply = 36V, $V_{\text{BIAS}} = 0.5\text{V to }25\text{V}$ (LT1787H)	●	100	130		dB
		$V_{\text{SENSE}} = 0\text{V}, V_S$ Supply = 60V, $V_{\text{BIAS}} = 0.5\text{V to }25\text{V}$ (LT1787HVH)	●	100	130		dB
$I_S^+(0)$	Positive Input Sense Current	$V_{\text{SENSE}} = 0\text{V}$	●	10	25	$\mu\text{A}$	
$I_S^-(0)$	Negative Input Sense Current	$V_{\text{SENSE}} = 0\text{V}$	●	50	115	$\mu\text{A}$	
$I_{EE(0)}$	Negative Supply Current	$V_{\text{SENSE}} = 0\text{V}$	●	60	140	$\mu\text{A}$	
$I_{\text{OUT}}$	Output Current	$V_{\text{SENSE}} = \pm 128\text{mV}$		$\pm 50$		$\mu\text{A}$	
$V_{\text{OUT}}$	Output Voltage	$V_{\text{SENSE}} = \pm 128\text{mV}, V_S^+ \geq 3.3\text{V}$		$V_{\text{BIAS}} \pm 1.024$		V	
	Ripple Rejection	$V_S^+ = V_S^- = 20\text{V}, \Delta V_S$ Supply = 1V, $f = 1\text{kHz}$	●	80	88	dB	

# LT1787/LT1787HV

## ELECTRICAL CHARACTERISTICS

The ● denotes the specifications which apply over the temperature range  $-40^{\circ}\text{C} \leq T_A \leq 125^{\circ}\text{C}$ , otherwise specifications are at  $T_A = 25^{\circ}\text{C}$ . Total supply =  $(V_S^- - V_{EE}) = 2.5\text{V to }36\text{V}$  (LT1787H),  $2.5\text{V to }60\text{V}$  (LT1787HVH) unless otherwise specified. (Note 5)

SYMBOL	PARAMETER	CONDITIONS	MIN	TYP	MAX	UNITS
V <sub>OMIN</sub>	Minimum Output Voltage	V <sub>SENSE</sub> = 0V, V <sub>BIAS</sub> = 0V		30	45	mV
		V <sub>SENSE</sub> = V <sub>S</sub> <sup>+</sup> - V <sub>S</sub> <sup>-</sup> = -128mV, V <sub>BIAS</sub> = 0V		10		mV
		V <sub>SENSE</sub> = 0V, V <sub>BIAS</sub> = 0V	●	30	55	mV
		V <sub>SENSE</sub> = V <sub>S</sub> <sup>+</sup> - V <sub>S</sub> <sup>-</sup> = -128mV, V <sub>BIAS</sub> = 0V		10		mV
	Unipolar Output Saturation Voltage	V <sub>SENSE</sub> = 2mV, V <sub>BIAS</sub> = 0V		32	50	mV
		V <sub>SENSE</sub> = 4mV, V <sub>BIAS</sub> = 0V		38	55	mV
		V <sub>SENSE</sub> = 5mV, V <sub>BIAS</sub> = 0V		43	60	mV
		V <sub>SENSE</sub> = 6mV, V <sub>BIAS</sub> = 0V		49	65	mV
		V <sub>SENSE</sub> = 2mV, V <sub>BIAS</sub> = 0V	●	32	60	mV
		V <sub>SENSE</sub> = 4mV, V <sub>BIAS</sub> = 0V	●	38	65	mV
		V <sub>SENSE</sub> = 5mV, V <sub>BIAS</sub> = 0V	●	43	70	mV
		V <sub>SENSE</sub> = 6mV, V <sub>BIAS</sub> = 0V	●	49	75	mV
V <sub>OMAX</sub>	Maximum Output Voltage			V <sub>S</sub> <sup>+</sup> - 0.75		V
R <sub>G1A</sub> , R <sub>G2A</sub>	Input Gain-Setting Resistor	Pin 1 to Pin 2, Pin 7 to Pin 8		1.25		kΩ
R <sub>OUT</sub>	Output Resistor	Pin 5 to Pin 6		20		kΩ

**Note 1:** Absolute Maximum Ratings are those values beyond which the life of a device may be impaired.

**Note 2:** ESD (Electrostatic Discharge) sensitive devices. Extensive use of ESD protection devices are used internal to the LT1787/LT1787HV, however, high electrostatic discharge can damage or degrade the device. Use proper ESD handling precautions.

**Note 3:** The LT1787C/LT1787I are guaranteed functional over the operating temperature range of  $-40^{\circ}\text{C}$  to  $85^{\circ}\text{C}$ . The LT1787H is guaranteed functional over the operating temperature range of  $-40^{\circ}\text{C}$  to  $125^{\circ}\text{C}$ .

**Note 4:** The LT1787C is guaranteed to meet specified performance from  $0^{\circ}\text{C}$  to  $70^{\circ}\text{C}$ . The LT1787C is designed, characterized and expected to meet specified performance from  $-40^{\circ}\text{C}$  to  $85^{\circ}\text{C}$  but is not tested or QA sampled at these temperatures. The LT1787I is guaranteed to meet specified performance from  $-40^{\circ}\text{C}$  to  $85^{\circ}\text{C}$ . The LT1787H is guaranteed to meet specified performance from  $-40^{\circ}\text{C}$  to  $125^{\circ}\text{C}$ .

**Note 5:** Testing done at V<sub>BIAS</sub> = 1.25V, V<sub>EE</sub> = 0V unless otherwise specified.

**Note 6:** This parameter is not 100% tested.

## TYPICAL PERFORMANCE CHARACTERISTICS

**Input Offset Voltage vs Supply Voltage**

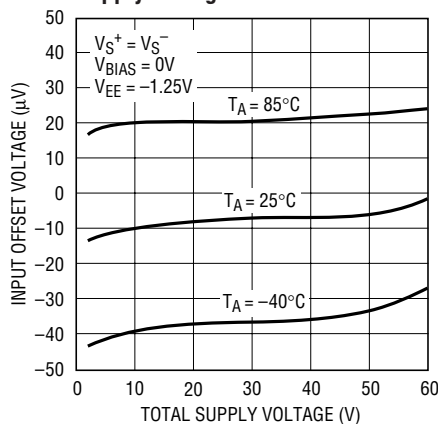

1787 G01

**No Load Output Voltage vs Supply Voltage**

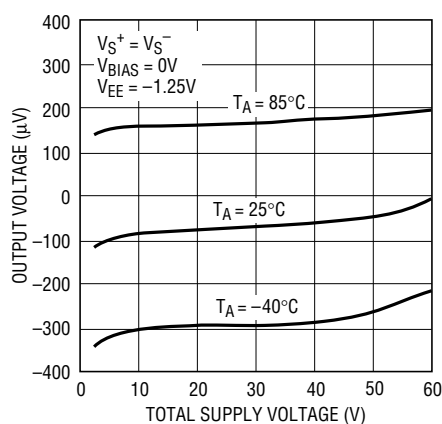

1787 G02

**No Load Output Current vs Supply Voltage**

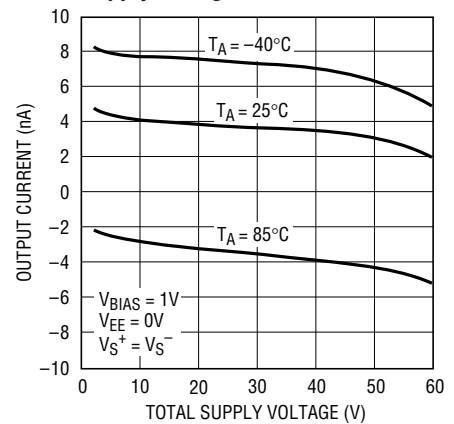

1787 G03

# TYPICAL PERFORMANCE CHARACTERISTICS

**Input Offset Voltage vs Negative Supply Voltage**

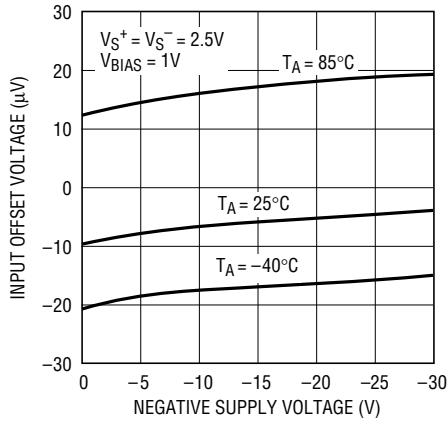

1787 G04

**Input Offset Voltage vs Temperature**

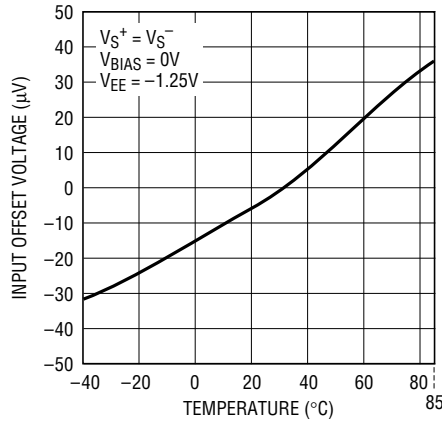

1787 G05

**Output Voltage vs Sense Voltage (Bidirectional Mode)**

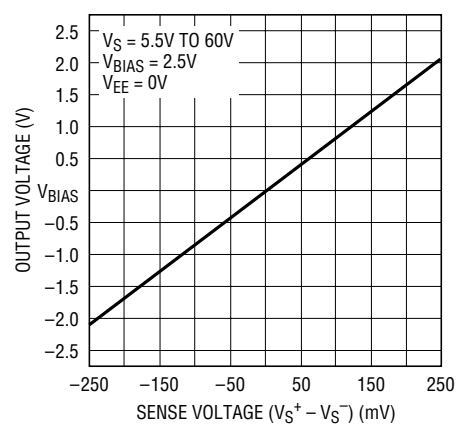

1787 G06

**Output Voltage vs Sense Voltage (Unidirectional Mode)**

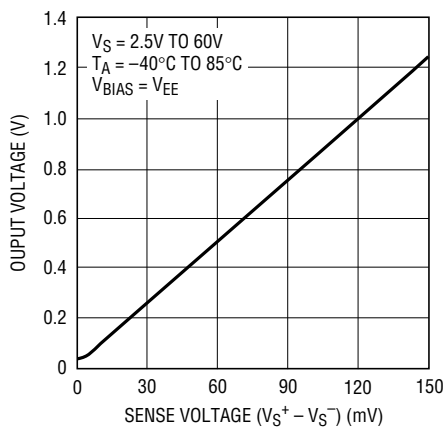

1787 G07

**Gain vs Temperature**

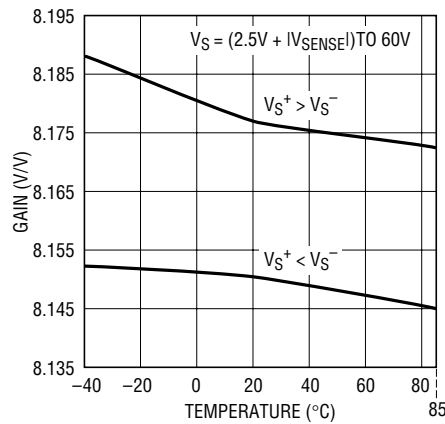

1787 G08

**Gain vs Frequency**

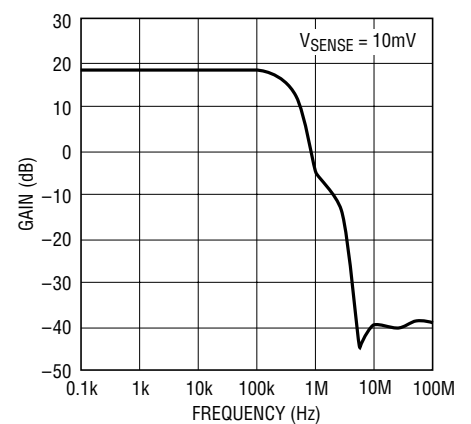

1787 G09

**Supply Current vs Supply Voltage**

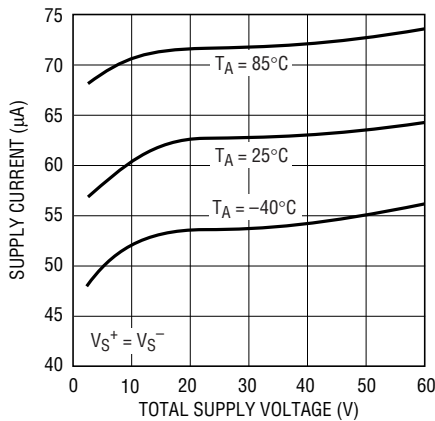

1787 G10

**Negative Input Sense Current vs Sense Voltage**

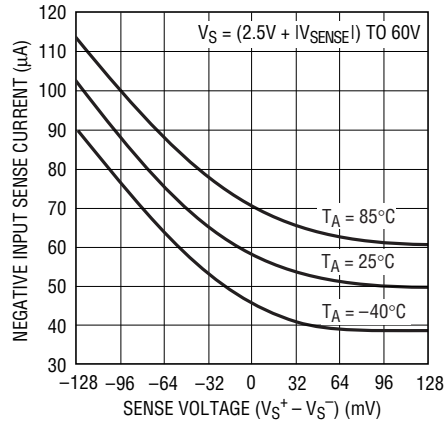

1787 G11

**Positive Input Sense Current vs Sense Voltage**

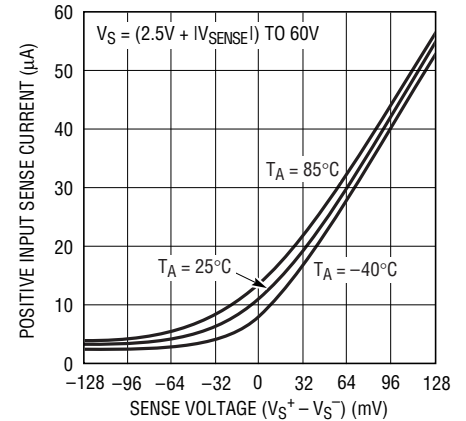

1787 G17



# LT1787/LT1787HV

## TYPICAL PERFORMANCE CHARACTERISTICS

Step Response at  
 $V_{SENSE} = 0V$  to  $10mV$

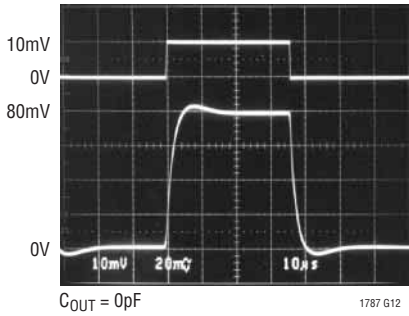

Step Response at  
 $V_{SENSE} = 0V$  to  $128mV$

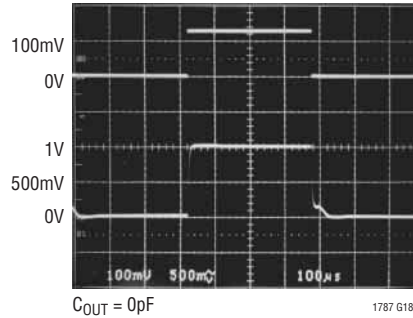

Step Response at  
 $V_{SENSE} = 0V$  to  $128mV$

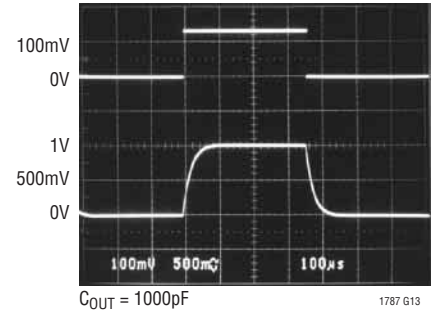

Step Response at  
 $V_{SENSE} = 0V$  to  $-128mV$

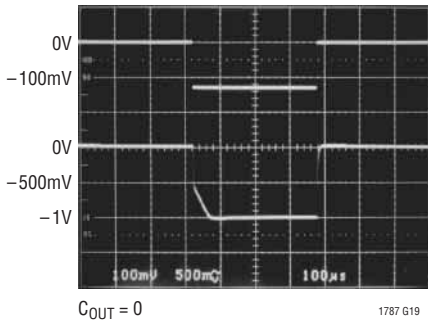

Step Response at  
 $V_{SENSE} = 0V$  to  $-128mV$

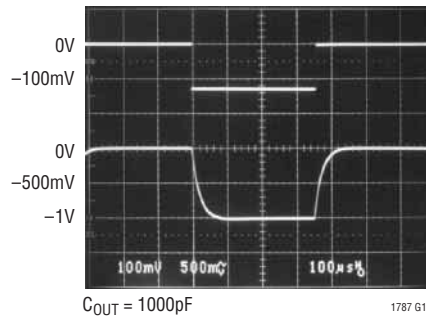

Step Response at  
 $V_{SENSE} = -128mV$  to  $128mV$

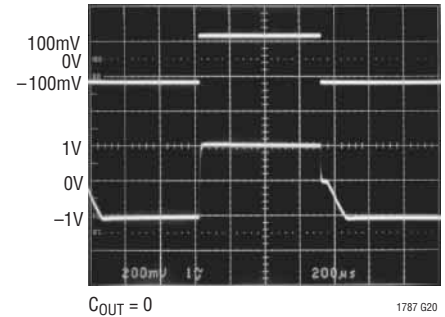

Step Response at  
 $V_{SENSE} = 128mV$  to  $-128mV$

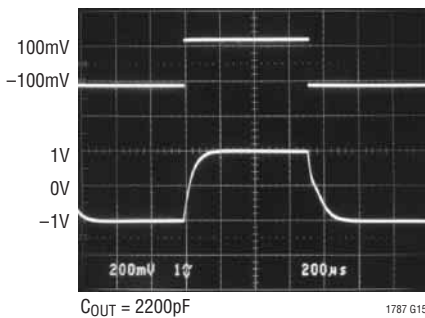

$V_{OUT}$  Error vs Supply Ripple  
Voltage ( $V_{SENSE} = \pm 128mV$ )

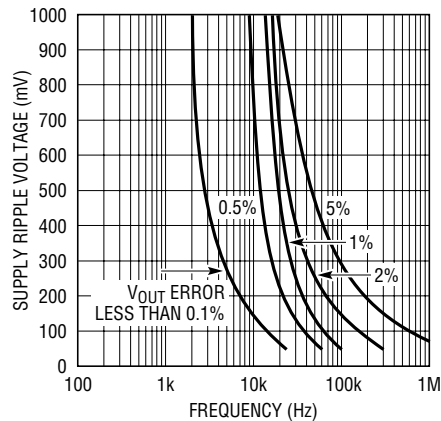

Output Voltage vs Sense Voltage

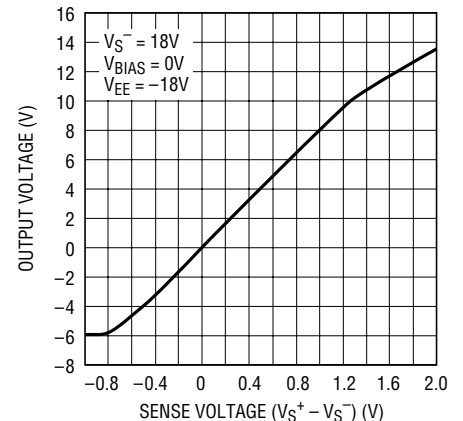



## PIN FUNCTIONS

**FIL<sup>-</sup>, FIL<sup>+</sup> (Pins 1, 8):** Negative and Positive Filter Terminals. Differential mode noise can be filtered by connecting a capacitor across FIL<sup>-</sup> and FIL<sup>+</sup>. Pole frequency  $f_{-3dB} = 1/(2\pi RC)$ ,  $R = 1.25k\Omega$ .

**V<sub>S</sub><sup>-</sup> (Pin 2):** Negative Input Sense Terminal. Negative sense voltage will result in an output sinking current proportional to the sense current. V<sub>S</sub><sup>-</sup> is connected to an internal gain-setting resistor R<sub>G1A</sub> and supplies bias current to the internal amplifier.

**DNC (Pin 3):** Do Not Connect. Connected internally. Do not connect external circuitry to this pin.

**V<sub>EE</sub> (Pin 4):** Negative Supply or Ground for Single Supply Operation.

**V<sub>OUT</sub> (Pin 5):** Voltage Output or Current Output proportional to the magnitude of the sense current flowing through R<sub>SENSE</sub>. For bidirectional current sensing operation,  $V_{OUT} = A_V \cdot V_{SENSE} + V_{OUT(0)} + V_{BIAS}$ ,

where:

$$\begin{aligned} V_{OUT} &> V_{BIAS} \text{ for } V_S^+ > V_S^- \\ V_{OUT} &< V_{BIAS} \text{ for } V_S^+ < V_S^- \end{aligned}$$

V<sub>OUT(0)</sub> is the no load output voltage at V<sub>SENSE</sub> = 0V.

**V<sub>BIAS</sub> (Pin 6):** Output Bias Pin. For single supply, bidirectional current sensing operation, V<sub>BIAS</sub> is connected to an external bias voltage, so that at V<sub>SENSE</sub> = 0V, V<sub>OUT</sub> = V<sub>OUT(0)</sub> + V<sub>BIAS</sub>. For dual supply, bidirectional current sensing operation, V<sub>BIAS</sub> is connected to ground. Thus, V<sub>OUT</sub> = V<sub>OUT(0)</sub> at V<sub>SENSE</sub> = 0V.

**V<sub>S</sub><sup>+</sup> (Pin 7):** Positive Input Sense Terminal. Positive sense voltage will result in an output sourcing current proportional to the sense current. V<sub>S</sub><sup>+</sup> is connected to an internal gain-setting resistor R<sub>G2A</sub>. Connecting a supply to V<sub>S</sub><sup>+</sup> and a load to V<sub>S</sub><sup>-</sup> will allow the LT1787 to measure its own supply current.

## BLOCK DIAGRAM

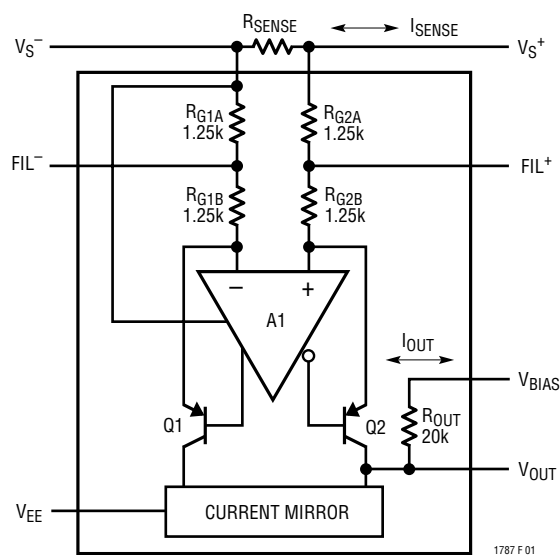

Figure 1. LT1787 Functional Diagram

## APPLICATIONS INFORMATION

The LT1787 high side current sense amplifier (Figure 1) provides accurate bidirectional monitoring of current through a user-selected sense resistor. The sense voltage is amplified by a fixed gain of 8 and level shifted from the positive power supply to the ground referenced outputs. The output signal may be used in a variety of ways to interface with subsequent signal processing circuitry. Input and output filtering are easily implemented to eliminate aliasing errors.

### Theory of Operation

Inputs  $V_S^+$  and  $V_S^-$  apply the sense voltage to matched resistors  $R_{G1}$  and  $R_{G2}$ . The opposite ends of resistors  $R_{G1}$  and  $R_{G2}$  are forced to be at equal potentials by the voltage gain of amplifier A1. The currents through  $R_{G1}$  and  $R_{G2}$  are forced to flow through transistors Q1 and Q2 and are summed at node  $V_{OUT}$  by the 1:1 current mirror. The net current from  $R_{G1}$  and  $R_{G2}$  flowing through resistor  $R_{OUT}$  gives a voltage gain of eight. Positive sense voltages result in  $V_{OUT}$  being positive with respect to pin  $V_{BIAS}$ .

Pins  $V_{EE}$ ,  $V_{BIAS}$  and  $V_{OUT}$  may be connected in a variety of ways to interface with subsequent circuitry. Split supply and single supply output configurations are shown in the following sections.

Supply current for amplifier A1 is drawn from the  $V_S^-$  pin. The user may choose to include this current in the monitored current through  $R_{SENSE}$  by careful choice of connection polarity.

### Selection of External Current Sense Resistor

External  $R_{SENSE}$  resistor selection is a delicate trade-off between power dissipation in the resistor and current measurement accuracy. The LT1787 makes this decision less difficult than with competitors' products. The maximum sense voltage may be as large as  $\pm 500\text{mV}$  to get maximum resolution, however, high current applications will not want to suffer this much power dissipation in the sense resistor. The LT1787's input offset voltage of  $40\mu\text{V}$  gives high resolution for low sense voltages. This wide operating dynamic range gives the user wide latitude in tailoring the range and resolution of his supply monitoring function.

Kelvin connection of the LT1787's  $V_S^+$  and  $V_S^-$  inputs to the sense resistor should be used in all but the lowest power applications. Solder connections and PC board interconnect resistance (approximately  $0.5\text{m}\Omega$  per square) can be a large error in high current systems. A 5-Amp application might choose a  $20\text{m}\Omega$  sense resistor to give a  $100\text{mV}$  full-scale input to the LT1787. Input offset voltage will limit resolution to  $2\text{mA}$ . Neglecting contact resistance at solder joints, even one square of PC board copper at each resistor end will cause an error of 5%. This error will grow proportionately higher as monitored current levels rise to tens or hundreds of amperes.

### Input Noise Filtering

The LT1787 provides input signal filtering pins  $FIL^+$  and  $FIL^-$  that are internally connected to the midpoint taps of resistors  $R_{G1}$  and  $R_{G2}$ . These pins may be used to filter the input signal entering the LT1787's internal amplifier, and should be used when fast current ripple or transients may flow through the sense resistor. High frequency signals above the  $300\text{kHz}$  bandwidth of the LT1787's internal amplifier will cause errors. A capacitor connected between  $FIL^+$  and  $FIL^-$  creates a single pole low pass filter with corner frequency:

$$f_{-3\text{dB}} = 1/(2\pi RC)$$

where  $R = 1.25\text{k}$ . A  $0.01\mu\text{F}$  capacitor creates a pole at  $12.7\text{kHz}$ , a good choice for many applications.

Common mode filtering from the  $FIL^+$  and  $FIL^-$  pins should not be attempted, as mismatch in the capacitors from  $FIL^+$  and  $FIL^-$  will create AC common mode errors. Common mode filtering must be done at the power supply output.

### Output Signal Range

The LT1787's output signal is developed by summing the net currents through  $R_{G1}$  and  $R_{G2}$  into output resistor  $R_{OUT}$ . The pins  $V_{OUT}$  and  $V_{BIAS}$  may be connected in numerous configurations to interface with following circuitry in either single supply or split supply applications. Care must be used in connecting the output pins to preserve signal accuracy. Limitations on the signal swing at  $V_{OUT}$  are imposed by the negative supply,  $V_{EE}$ , and the input voltage  $V_S^+$ . In the negative direction, internal circuit saturation with loss of accuracy occurs for  $V_{OUT} < 70\text{mV}$

## APPLICATIONS INFORMATION

with absolute minimum swing at 30mV above  $V_{EE}$ .  $V_{OUT}$  may swing positive to within 0.75V of  $V_S^+$  or a maximum of 35V, a limit set by internal junction breakdown. Within these constraints, an amplified, level shifted representation of the  $R_{SENSE}$  voltage is developed across  $R_{OUT}$ .

### Split Supply Bipolar Output Swing

Figure 2 shows the LT1787 used with split power supplies. The  $V_{BIAS}$  pin is connected to ground, and the output signal appears at the  $V_{OUT}$  pin. Bidirectional input currents can be monitored with the output swinging positive for current flow from  $V_S^+$  and  $V_S^-$ . Input currents in the opposite direction cause  $V_{OUT}$  to swing below ground. Figure 2 shows an optional output capacitor connected from  $V_{OUT}$  to ground. This capacitor may be used to filter the output signal before it is processed by other circuitry. Figure 3 shows the voltage transfer function of the LT1787 used in this configuration.

### Single Supply with Shifted $V_{BIAS}$

Figure 4 shows the LT1787 used in a single supply mode with the  $V_{BIAS}$  pin shifted positive using an external LT1634 voltage reference. The  $V_{OUT}$  output signal can swing above and below  $V_{BIAS}$  to allow monitoring of positive or negative currents through the sense resistor, as shown in Figure 5. The choice of reference voltage is not critical except for the precaution that adequate headroom must be provided for  $V_{OUT}$  to swing without saturating the internal circuitry. The component values shown in Figure 4 allow operation with  $V_S$  supplies as low as 3.1V.

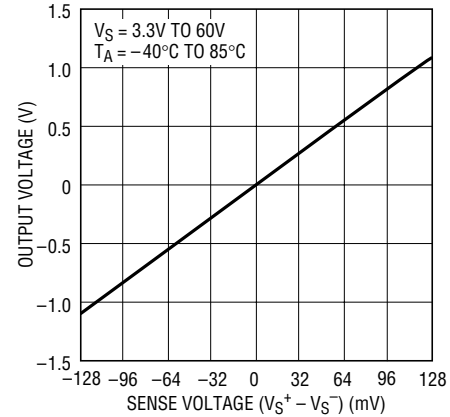

Figure 3. Split Supply Output Voltage

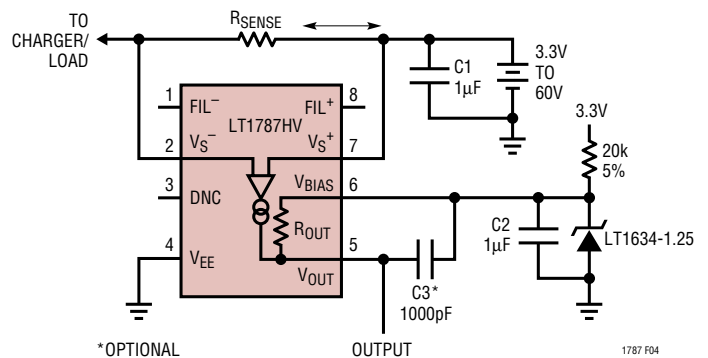

Figure 4. Charge/Discharge Current Monitor on Single Supply with  $V_{BIAS} = 1.25V$

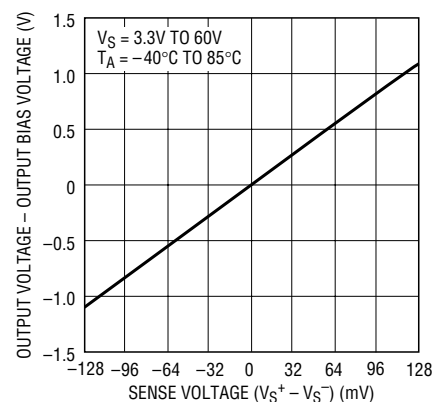

Figure 5. Single Supply Output Voltage with  $V_{BIAS} = 1.25V$

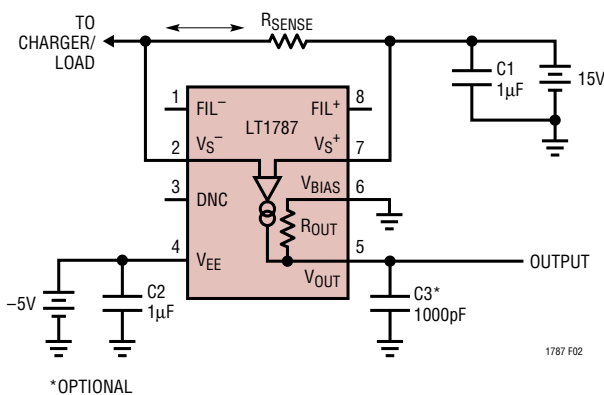

Figure 2. Split Supply Operation

## APPLICATIONS INFORMATION

### Operation with A/D Converter

Figure 6 shows the LT1787 operating with the LTC1286 A/D converter. This low cost circuit is capable of 12-bit resolution of unipolar currents. The  $-IN$  pin of the A/D converter is biased at 1V by the resistor divider R1 and R2. This voltage increases as sense current increases, with the amplified sense voltage appearing between the A/D converters  $-IN$  and  $+IN$  terminals. The front page of the data sheet shows a similar circuit which uses a voltage reference for improved accuracy and signal range. The LTC1286 converter uses sequential sampling of its  $-IN$  and  $+IN$  inputs. Accuracy is degraded if the inputs move between sampling intervals. A filter capacitor from  $FIL^+$  to  $FIL^-$  as well as a filter capacitor from  $V_{BIAS}$  to  $V_{OUT}$  may be necessary if the sensed current changes more than 1LSB within a conversion cycle.

### Buffered Output Operation

Figure 7 shows the LT1787's outputs buffered by an operational amplifier configured as an I/V converter. This configuration is ideal for monitoring very low voltage supplies. The LT1787's  $V_{OUT}$  pin is held equal to the reference voltage appearing at the op amp's noninverting input. This allows monitoring  $V_S$  supplies as low as 2.5V. The op amp's output may swing from ground to its positive supply voltage. The low impedance output of the op amp may drive following circuitry more effectively than the high output impedance of the LT1787. The I/V converter configuration also works well with split supply voltages.

### Single Supply Unidirectional Operation

Figure 8 shows the simplest connection in which the LT1787 may be used. The  $V_{BIAS}$  pin is connected to ground, and the  $V_{OUT}$  pin swings positive with increasing sense current. The LT1787's outputs can swing as low as 30mV as shown in Figure 9. Accuracy is sacrificed at small output levels, but this is not a limitation in protection circuit applications or where sensed currents do not vary greatly. Increased low level accuracy can be obtained by level shifting  $V_{BIAS}$  above ground. The level shifting may be done with resistor dividers, voltage references or a simple diode. Accuracy is ensured if the output signal is sensed differentially between  $V_{BIAS}$  and  $V_{OUT}$ .

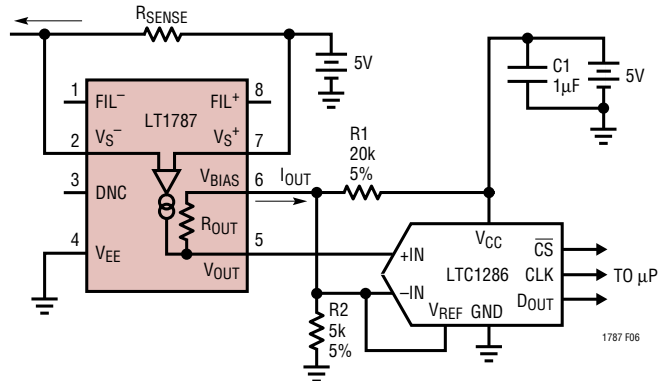

Figure 6. Unidirectional Output into A/D with Fixed Supply at  $V_S^+$

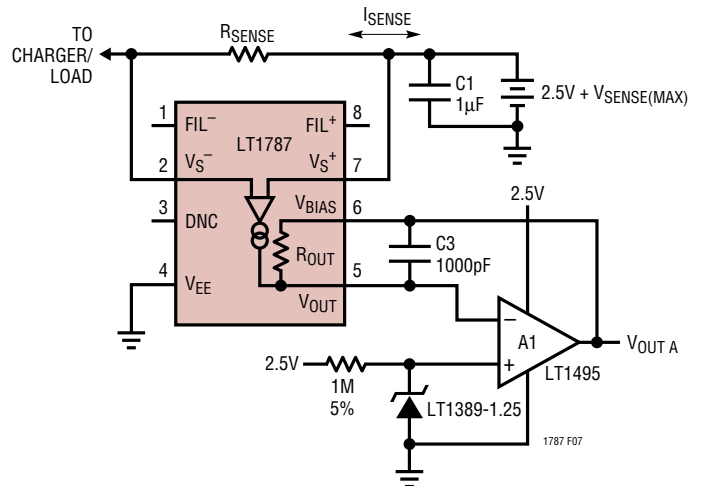

Figure 7. Single Supply 2.5V Bidirectional Operation with External Voltage Reference and I/V Converter

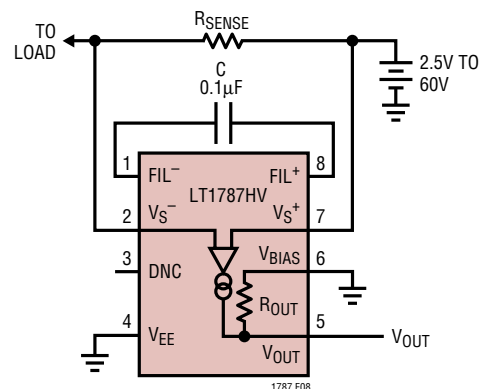

Figure 8. Unidirectional Current Sensing Mode

## APPLICATIONS INFORMATION

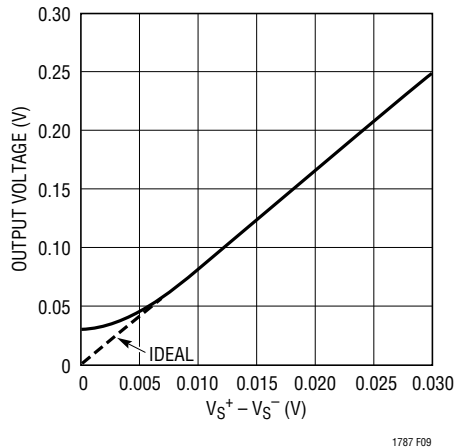

Figure 9. Expanded Scale of Unidirectional Output

### Adjusting Gain Setting

The LT1787 may be used in all operating modes with an external resistor used in place of the internal 20k  $R_{OUT}$

resistor. When an external resistor is used, leave the  $V_{BIAS}$  pin floating or connected to the  $V_{OUT}$  pin. This will remove the internal  $R_{OUT}$  from the circuit.

The voltage gain will be  $g_m \cdot R_{OUT}$  where  $g_m$  is the LT1787's transconductance, 400 $\mu$ A/V typical. A nominal gain of 40 may be obtained with an external 100k resistor used in place of the internal 20k  $R_{OUT}$ :

$$A_V = g_m \cdot R_{OUT} = 400\mu\text{A/V} \cdot 100\text{k} = 40$$

The transconductance  $g_m$  is set by on-chip resistors on the LT1787. These resistors match well but have loose absolute tolerance. This will normally require that the external gain setting resistor be trimmed for initial accuracy. After trimming, the temperature stability of the  $g_m$  and therefore gain will be  $-200\text{ppm}/^\circ\text{C}$ .

The only limitations placed upon the resistor choice is care must be taken not to saturate the internal circuitry by violating the  $V_{OMAX}$  specification of  $V_S + -0.75\text{V}$ .

**PACKAGE DESCRIPTION**

**MS8 Package**  
**8-Lead Plastic MSOP**  
 (LTC DWG # 05-08-1660)

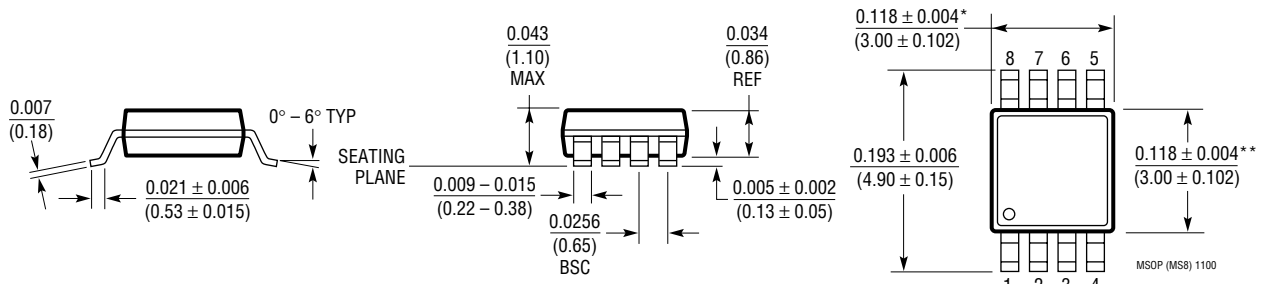

\* DIMENSION DOES NOT INCLUDE MOLD FLASH, PROTRUSIONS OR GATE BURRS. MOLD FLASH, PROTRUSIONS OR GATE BURRS SHALL NOT EXCEED 0.006\* (0.152mm) PER SIDE

\*\* DIMENSION DOES NOT INCLUDE INTERLEAD FLASH OR PROTRUSIONS. INTERLEAD FLASH OR PROTRUSIONS SHALL NOT EXCEED 0.006\* (0.152mm) PER SIDE

**PACKAGE DESCRIPTION**

**S8 Package**  
**8-Lead Plastic Small Outline (Narrow 0.150)**  
 (LTC DWG # 05-08-1610)

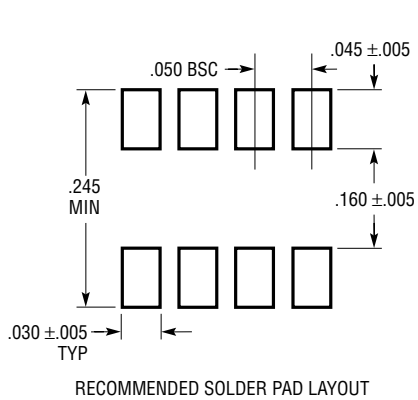

RECOMMENDED SOLDER PAD LAYOUT

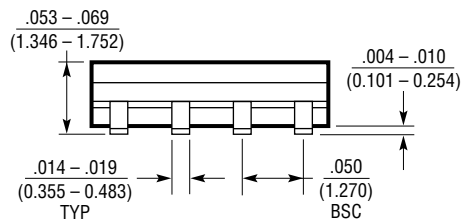
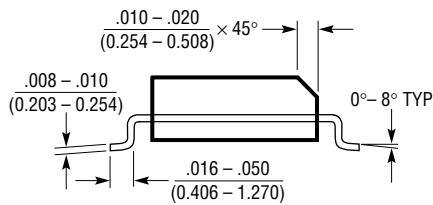
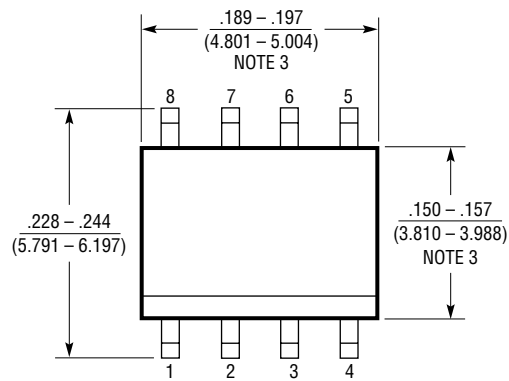

- NOTE:  
 1. DIMENSIONS IN INCHES (MILLIMETERS)  
 2. DRAWING NOT TO SCALE  
 3. THESE DIMENSIONS DO NOT INCLUDE MOLD FLASH OR PROTRUSIONS. MOLD FLASH OR PROTRUSIONS SHALL NOT EXCEED .006" (0.15mm)

S08 0303



# LT1787/LT1787HV

## TYPICAL APPLICATION

Split or Single Supply Operation, Bidirectional Output into A/D

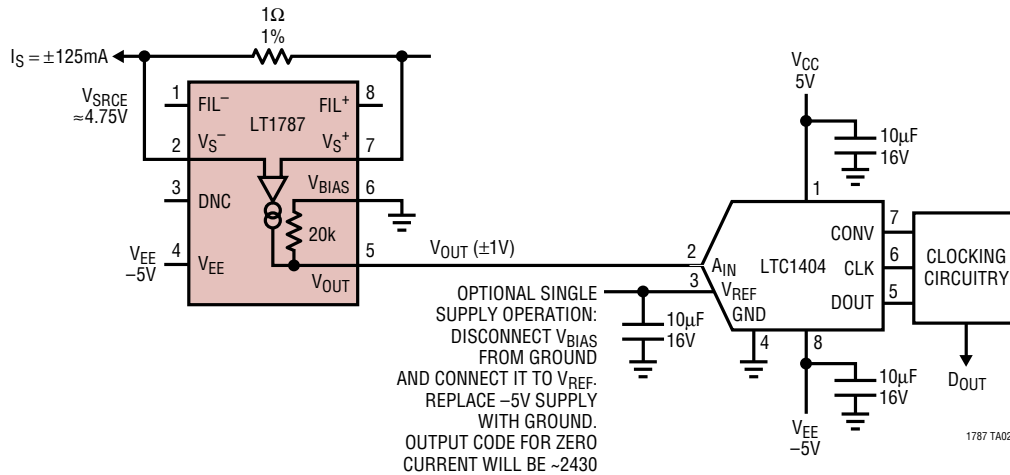

## RELATED PARTS

PART NUMBER	DESCRIPTION	COMMENTS
LTC1043	Dual Precision Instrumentation Switched Capacitor Building Block	120dB CMRR, 3V to 18V Operation
LT1490/LT1491	Dual and Quad Micropower Rail-to-Rail Input and Output Op Amps	50μA Amplifier, 2.7V to 40V Operation, Over-The-Top™ Inputs
LT1620/LT1621	Rail-to-Rail Current Sense Amplifiers	Accurate Output Current Programming, Battery Charging to 32V

Over-The-Top is a trademark of Linear Technology Corporation.